

FIG. 1

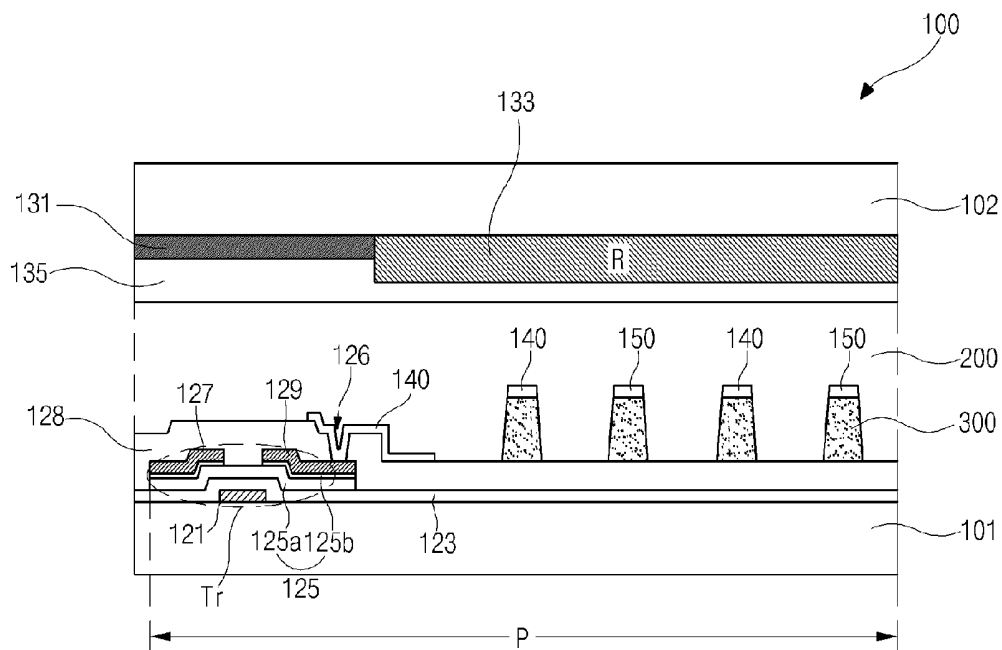

FIG. 2

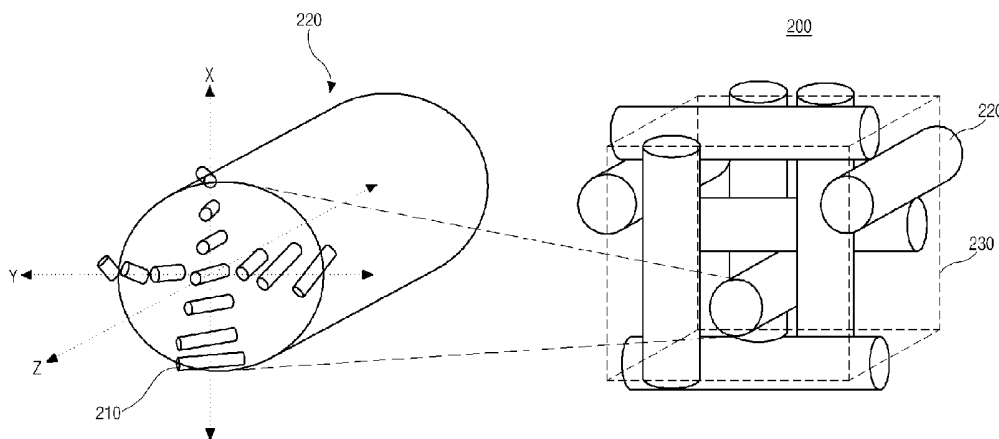

FIG. 3A

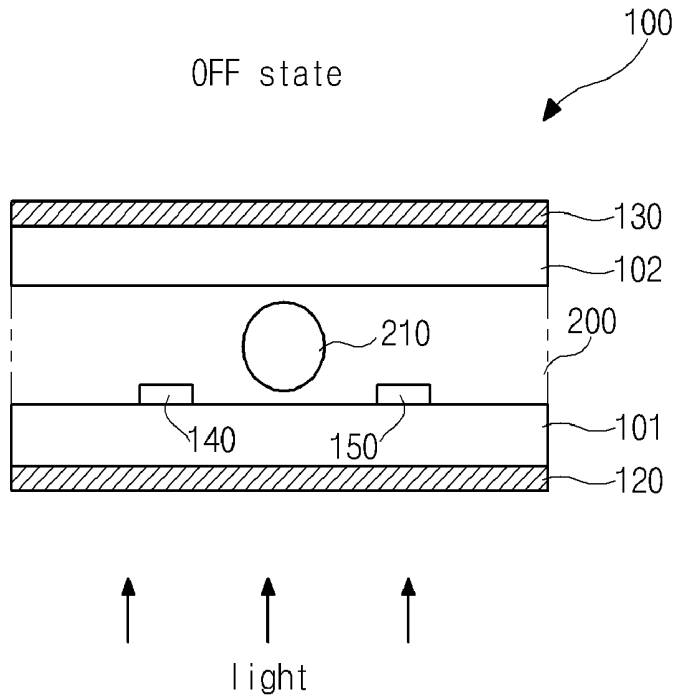

FIG. 3B

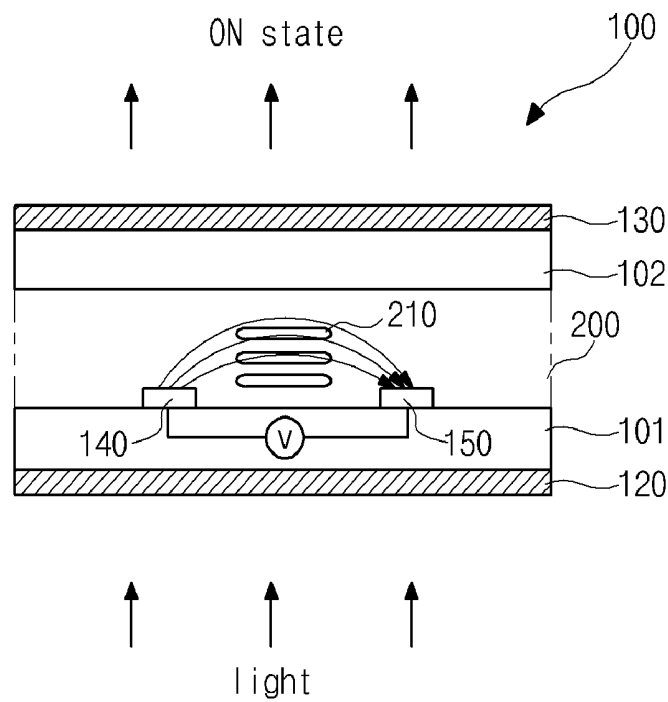

FIG. 4

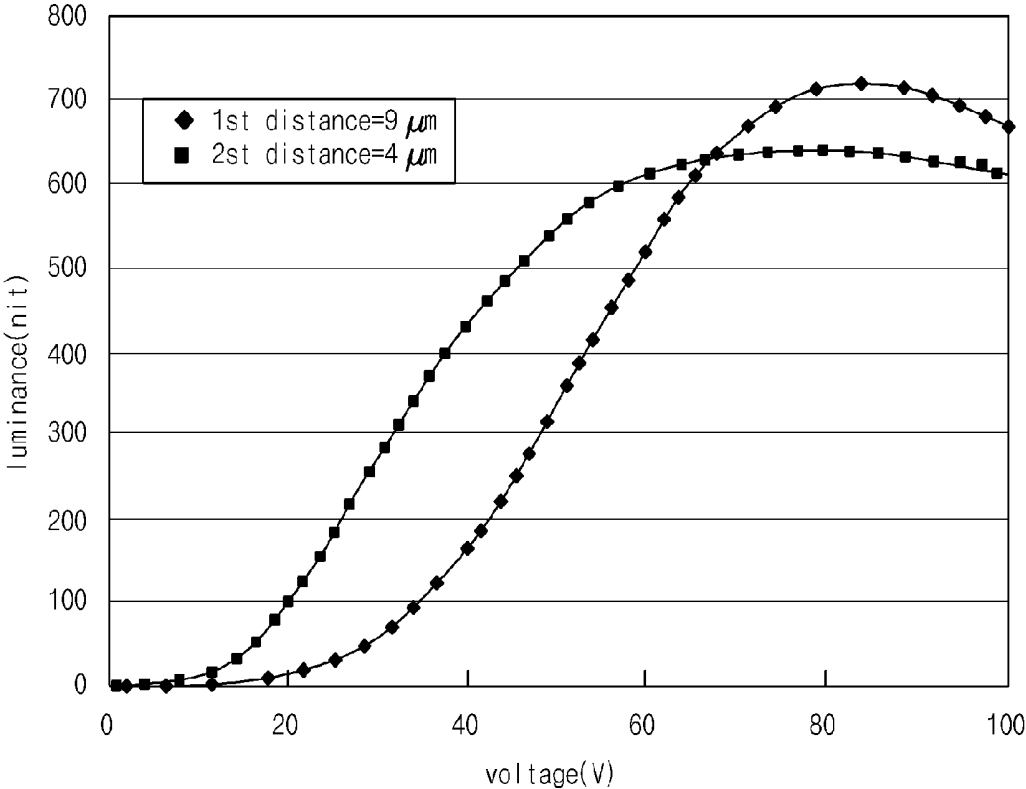

FIG. 5A

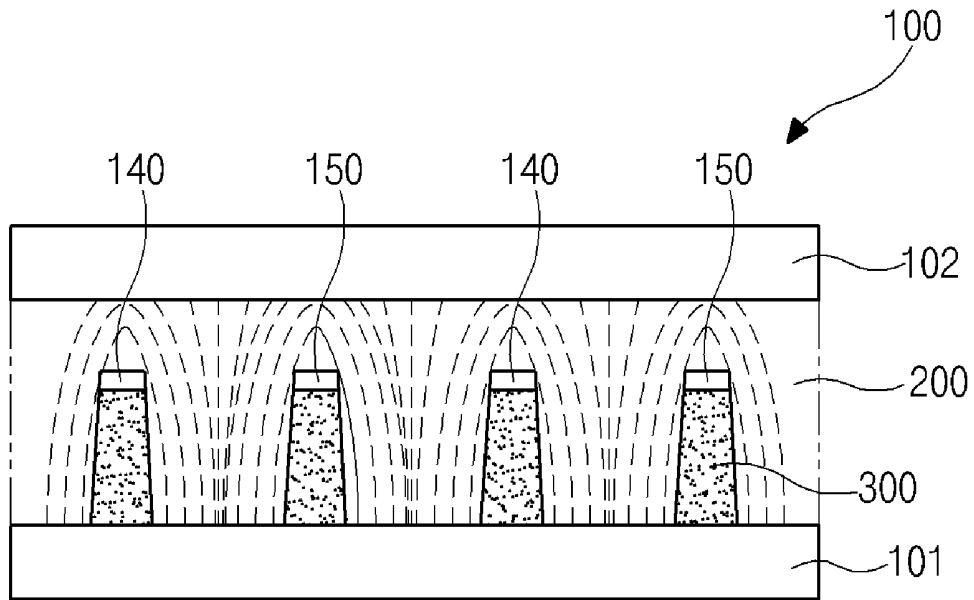

FIG. 5B

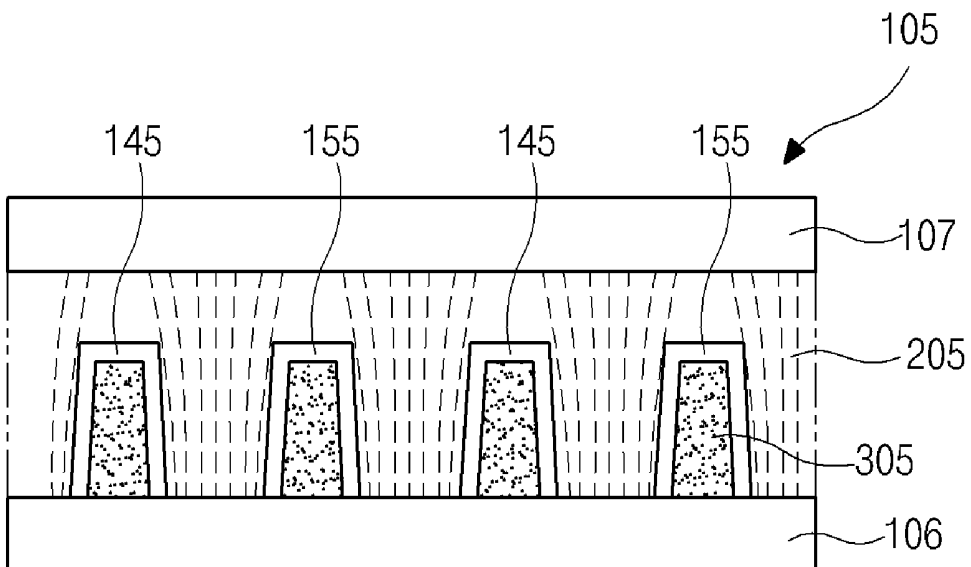

FIG. 6

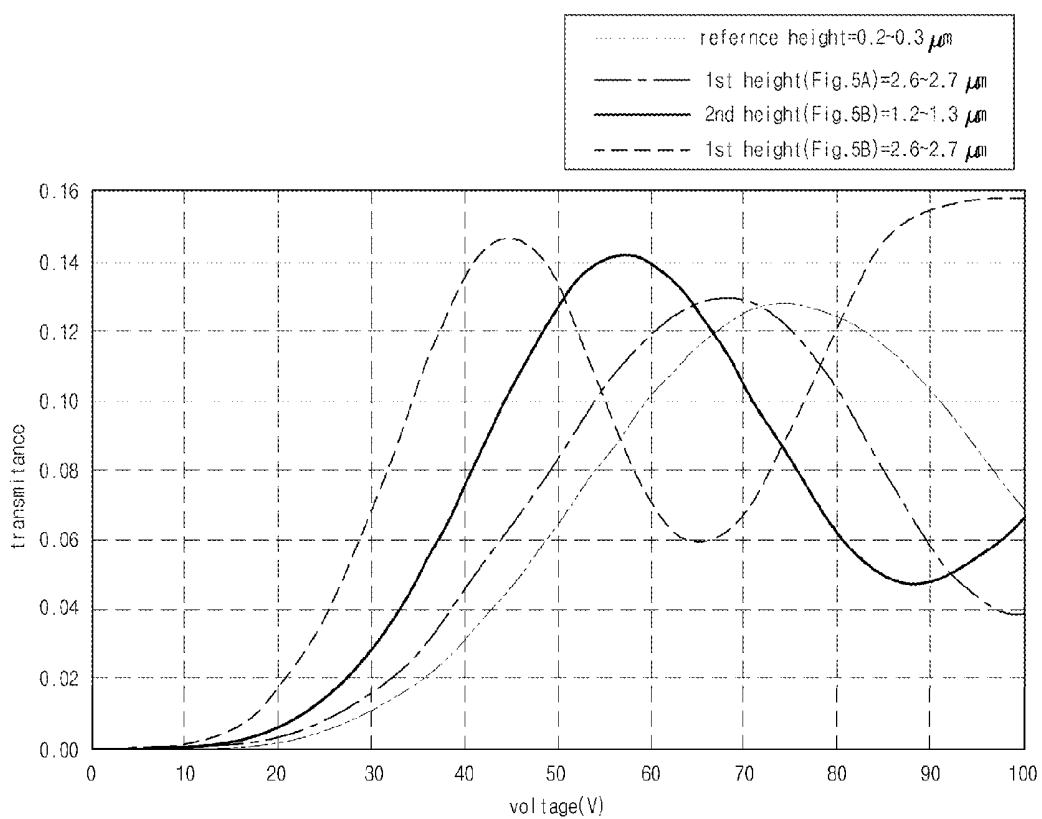

FIG. 7A

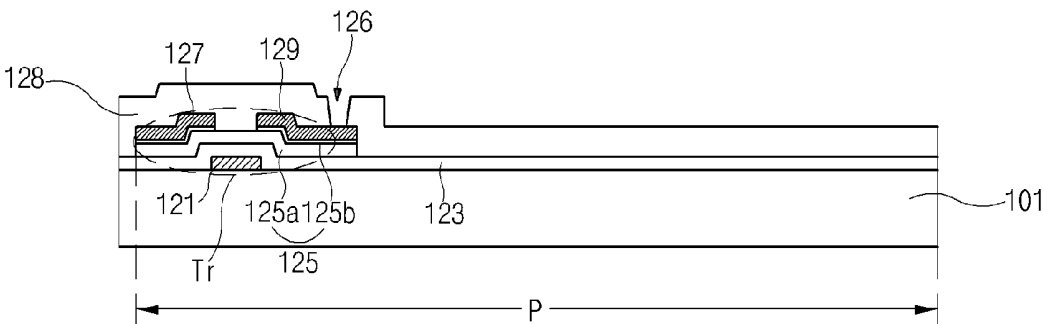

FIG. 7B

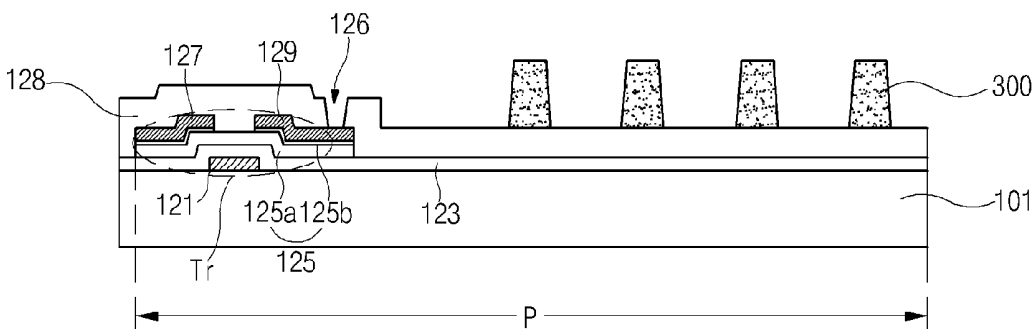

FIG. 7C

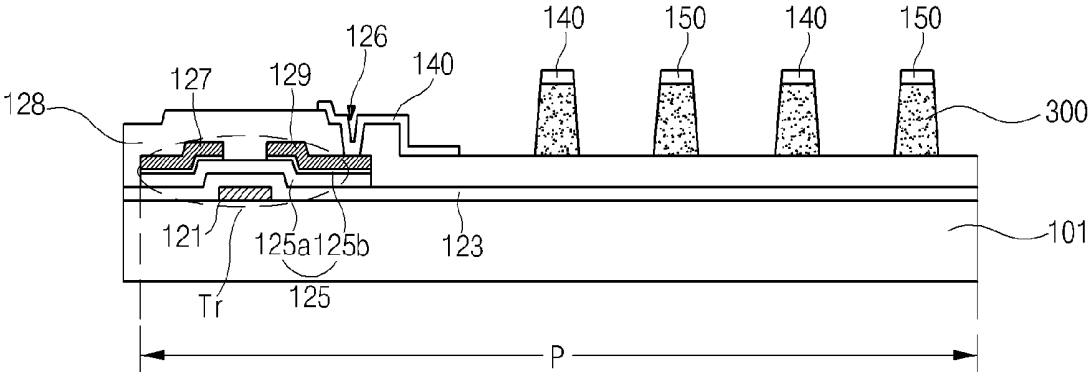

FIG. 8A400

optic axis, helical axis

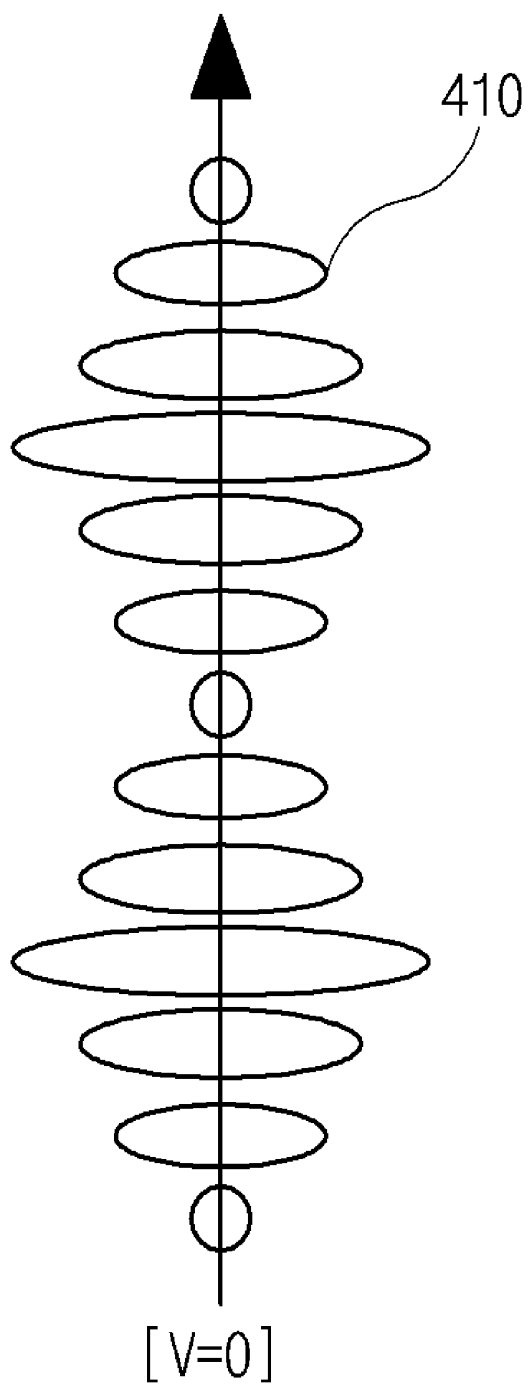

FIG. 8B

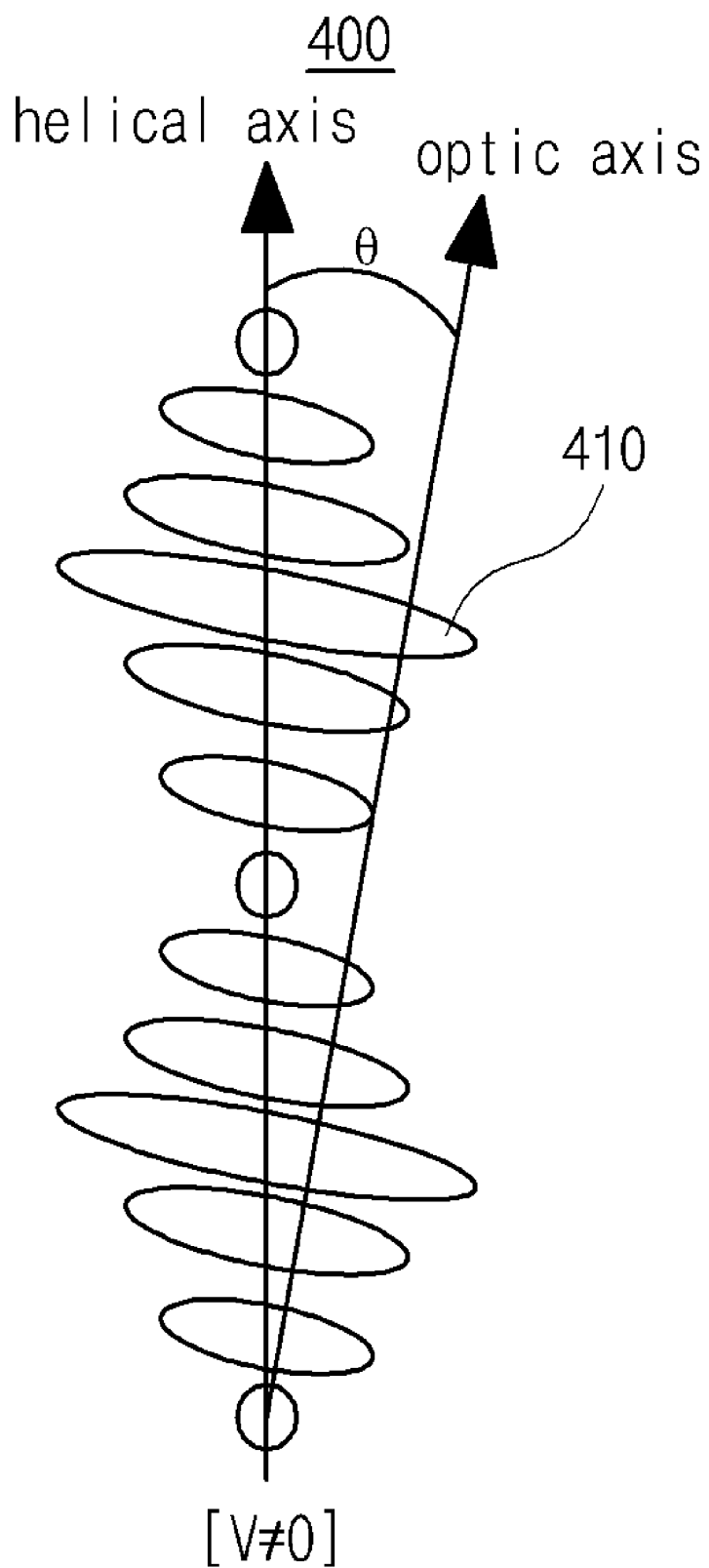

FIG. 9A

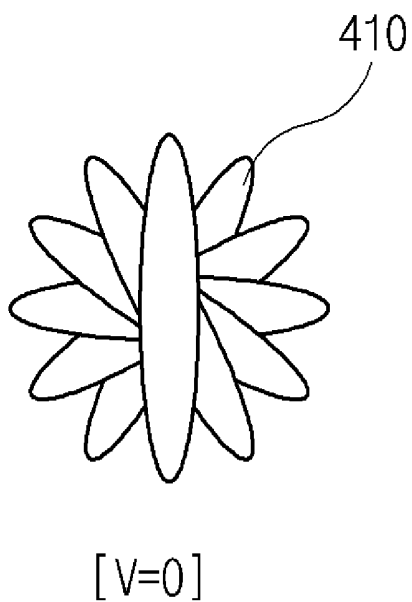

FIG. 9B

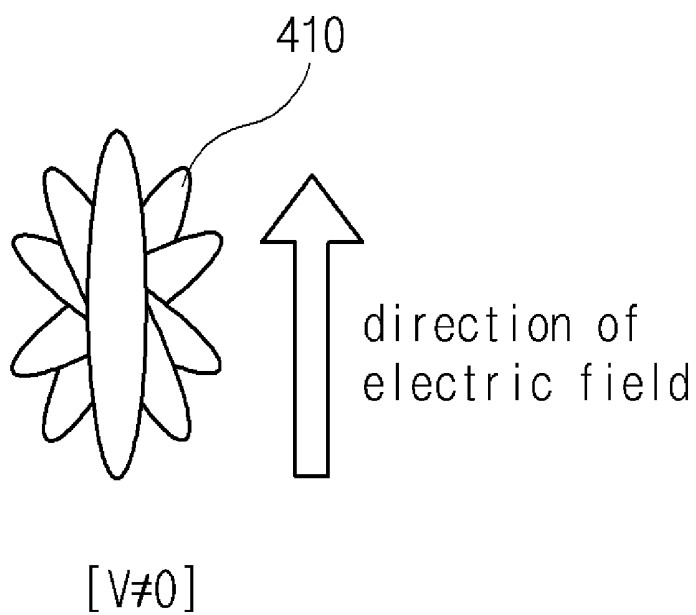

FIG. 10A

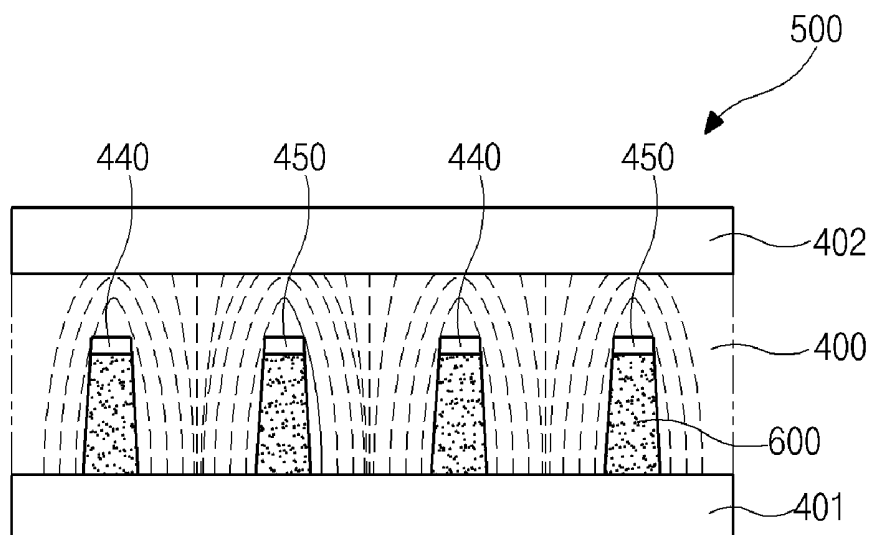
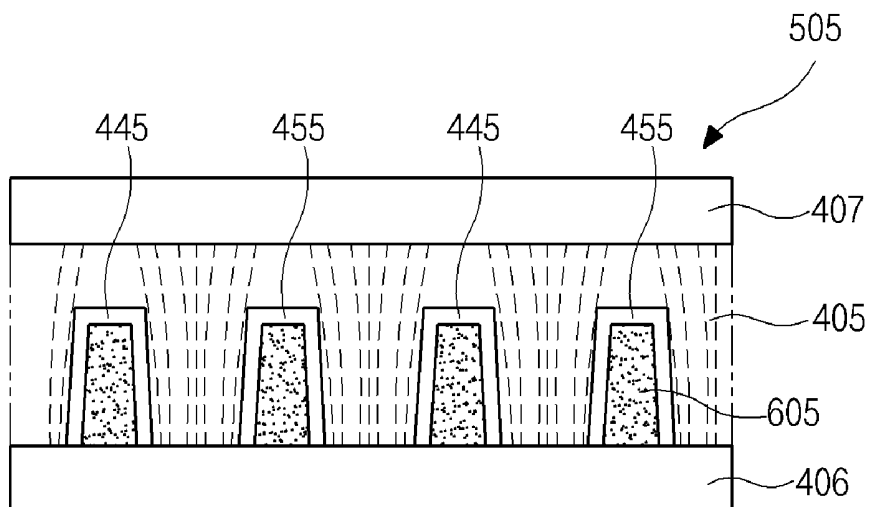

FIG. 10B



LIQUID CRYSTAL DISPLAY DEVICE

[0001] The present application claims the benefit of Korean Patent Application No. 10-2009-0123495 filed in Korea on Dec. 11, 2009, which is hereby incorporated by reference in its entirety.

BACKGROUND OF THE INVENTION

[0002] 1. Field of the Invention

[0003] The present invention relates to a liquid crystal display (LCD) device, and more particularly, to a liquid crystal display device where a driving voltage is reduced due to pixel and common electrodes in a liquid crystal layer.

[0004] 2. Discussion of the Related Art

[0005] As information technology progresses, flat panel display (FPD) devices having light weight, thin profile and low power consumption have been developed. Specifically, a cathode ray tube (CRT) has been replaced by the FPD devices such as a liquid crystal display (LCD) device, a plasma panel display (PDP) device, an electroluminescent display (ELD) device and a field emission display (FED) device.

[0006] Among various FPD devices, LCD devices have been widely used for a notebook computer, a monitor and a television due to their superiority in displaying moving images and high contrast ratio. LCD devices include a liquid crystal layer and the liquid crystal layer may include one of nematic liquid crystal molecules, smectic liquid crystal molecules and cholesteric liquid crystal molecules.

[0007] Since LCD devices have a low response speed, a display quality of LCD devices is deteriorated due to a residual image. Accordingly, LCD devices having a high response speed have been the subject of recent research and development. Specifically, a uniform standing helix (USH) mode LCD device and a blue phase mode LCD device have been suggested. However, a USH mode LCD device and a blue phase mode LCD device have disadvantages of a high driving voltage.

SUMMARY OF THE INVENTION

[0008] Accordingly, the present invention is directed to a liquid crystal display device that substantially obviates one or more of the problems due to limitations and disadvantages of the related art.

[0009] An object of the present invention is to provide a liquid crystal display device where a driving voltage is reduced and a respond speed is improved.

[0010] Additional features and advantages of the invention will be set forth in the description which follows, and in part will be apparent from the description, or may be learned by practice of the invention. The objectives and other advantages of the invention will be realized and attained by the structure particularly pointed out in the written description and claims hereof as well as the appended drawings.

[0011] To achieve these and other advantages and in accordance with the purpose of the present invention, as embodied and broadly described herein, a liquid crystal display device includes: first and second substrates facing and spaced apart from each other; a plurality of insulating patterns on an inner surface of the first substrate; a plurality of pixel electrodes and a plurality of common electrodes on the plurality of insulating patterns, the plurality of pixel electrodes alternating with the plurality of common electrodes, the adjacent pixel and com-

mon electrodes generating a horizontal electric field according to a driving voltage; and a liquid crystal layer between the first and second substrates, the liquid crystal layer including one of a blue phase liquid crystal molecules and a uniform standing helix liquid crystal molecules.

[0012] It is to be understood that both the foregoing general description and the following detailed description are exemplary and explanatory and are intended to provide further explanation of the invention as claimed.

BRIEF DESCRIPTION OF THE DRAWINGS

[0013] The accompanying drawings, which are included to provide a further understanding of the invention and are incorporated in and constitute a part of this specification, illustrate embodiments of the invention and together with the description serve to explain the principles of the invention. In the drawings:

[0014] FIG. 1 is a cross-sectional view showing a blue phase mode liquid crystal display device according to a first embodiment of the present invention;

[0015] FIG. 2 is a view showing a blue phase liquid crystal layer of a blue phase mode liquid crystal display device according to a first embodiment of the present invention;

[0016] FIGS. 3A and 3B are cross-sectional views showing OFF and ON states, respectively, of a blue phase mode liquid crystal display device according to a first embodiment of the present invention;

[0017] FIG. 4 is a graph showing a luminance change according to a voltage applied to a pixel electrode and a common electrode in a blue phase mode liquid crystal display device according to a first embodiment of the present invention;

[0018] FIG. 5A is a cross-sectional view showing a pixel electrode and a common electrode of a blue phase mode liquid crystal display device according to a first embodiment of the present invention;

[0019] FIG. 5B is a cross-sectional view showing a pixel electrode and a common electrode of a blue phase mode liquid crystal display device according to a second embodiment of the present invention;

[0020] FIG. 6 is a graph showing a transmittance change according to a voltage applied to a pixel electrode and a common electrode in blue phase mode liquid crystal display devices according to first and second embodiments of the present invention;

[0021] FIGS. 7A to 7C are cross-sectional views showing a method of fabricating an array substrate for a blue phase mode liquid crystal display device according to a first embodiment of the present invention;

[0022] FIGS. 8A and 8B are side views showing an OFF state and an ON state, respectively, of a uniform standing helix liquid crystal layer for a liquid crystal display device according to a third embodiment of the present invention;

[0023] FIGS. 9A and 9B are front views showing an OFF state and an ON state, respectively, of a uniform standing helix liquid crystal layer for a liquid crystal display device according to a third embodiment of the present invention;

[0024] FIG. 10A is a cross-sectional view showing a pixel electrode and a common electrode of a uniform standing helix mode liquid crystal display device according to a second embodiment of the present invention; and

[0025] FIG. 10B is a cross-sectional view showing a pixel electrode and a common electrode of a uniform standing helix

mode liquid crystal display device according to a fourth embodiment of the present invention.

DETAILED DESCRIPTION OF THE PREFERRED EMBODIMENTS

[0026] Reference will now be made in detail to the preferred embodiments, examples of which are illustrated in the accompanying drawings.

[0027] FIG. 1 is a cross-sectional view showing a blue phase mode liquid crystal display device according to a first embodiment of the present invention, and FIG. 2 is a view showing a blue phase liquid crystal layer of a blue phase mode liquid crystal display device according to a first embodiment of the present invention.

[0028] In FIG. 1, a blue phase mode liquid crystal display (LCD) device 100 includes first and second substrates 101 and 102 facing and spaced apart from each other and a blue phase liquid crystal layer 200 between the first and second substrates 101 and 102. The blue phase liquid crystal layer 200 has an optically isotropic state in a 3-dimension or a 2-dimension when no electric field is applied, while the blue phase liquid crystal layer 200 has a birefringence when an electric field is applied. Accordingly, when a voltage is applied, the blue phase liquid crystal layer 200 has a uniaxial property and a viewing angle dependency in transmittance similarly to a nematic liquid crystal layer. In addition, since the blue phase liquid crystal layer 200 does not have an initial alignment of an optically anisotropic state, the blue phase liquid crystal layer 200 is re-aligned along a direction of an electric field differently from a nematic liquid crystal layer. For example, the blue phase liquid crystal layer 200 may have a smectic blue phase and a cholesteric blue phase.

[0029] In FIG. 2, a blue phase liquid crystal layer 200 includes a plurality of double twist cylinders (DTCs) 220 arranged in a cubic lattice 230. Each of the plurality of DTCs 220 includes liquid crystal molecules 210 arranged along two axes (x and y axes) perpendicular to an axis (z axis) of a cylinder with a twist angle. The outer liquid crystal molecules with respect to the z axis are twisted with a larger twist angle. Accordingly, the liquid crystal molecules 210 in each of the plurality of DTCs 220 have a directional property with respect to the axis (z axis) of the cylinder.

[0030] The blue phase of the liquid crystal molecules 210 is obtained under a temperature range between a chiral nematic phase and an isotropic phase. For example, the blue phase may be obtained under a narrow temperature range of about 1~2° C. Accordingly, an exact temperature control is required to obtain the blue phase of the liquid crystal molecules 210.

[0031] To enlarge the temperature range for the blue phase, the cubic lattice 230 of the plurality of DTCs 220 of the blue phase may be stabilized by a polymer. When the polymer is mixed with the liquid crystal molecules 210, the polymer is combined with the liquid crystal molecules 210 having no directional property rather than the liquid crystal molecules 210 having the directional property in the plurality of DTCs 220. As a result, the cubic lattice 230 of the plurality of DTCs 220 is stabilized and the temperature range for the blue phase is enlarged to about 0~50° C.

[0032] For example, the liquid crystal molecules 210 stabilized by a polymer may include one of the following three materials.

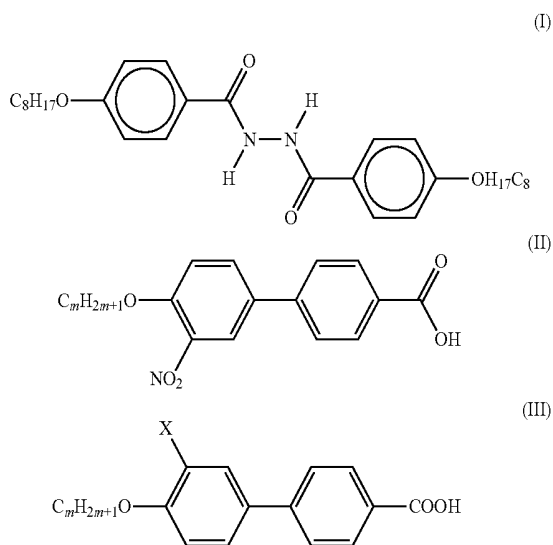

In addition, the liquid crystal molecules 210 stabilized by a polymer may include 4-cyano-4'-pentylbiphenyl or a composition of above four materials.

[0033] The liquid crystal molecules 210 stabilized by a polymer may include a monomer, a photoinitiator and a polymer such as a binder. The polymer stabilizes the liquid crystal molecules 210 and enlarges the temperature range for a blue phase to about 0~50° C. The monomer includes a photopolymerizable compound having a carbon-to-carbon unsaturated bond and a carbon-to-carbon ring-shaped bond. For example, the monomer may include an acrylic compound such as 1,3-butylene glycol diacrylate, 1,4-butanediol diacrylate and ethylene glycol diacrylate. The photoinitiator is an initiator for photo-polymerization and includes at least one acetophenone compound. For example, the photoinitiator may include diethoxyacetophenone, 2-methyl-2-monopolyno-1-(4-methylthiophenyl)propane-1-one, 2-hydroxy-2-methyl-1-phenylpropane-1-one. In addition, the photoinitiator may include a benzoin compound, a benzophenone compound, a thioxanthone compound and a triazine compound. For example, the benzoin compound may include benzoin, benzoinmethylether and benzomethylether. The thioxanthone compound may include 2-isopropylthioxanthone, 4-isopropylthioxanthone and 2,4-diethylthioxanthone, and the triazine compound may include 2,4-trichloromethyl-(piperonyl)-6-triazine, 2,4-bis(trichloromethyl)-6-(4-methoxynaphthyl)-1,3,5-triazine.

[0034] The binder includes an acrylic co-polymer having a co-polymer of a carboxylic monomer and the other monomer co-polymerizable with the carboxylic monomer. For example, the carboxylic monomer may be an unsaturated carboxylic acid and the unsaturated carboxylic acid may include an acrylic acid, a methacrylic acid and a crotonic acid. The monomer co-polymerizable with the carboxylic monomer may include styrene, α -methylstyrene, o-vinyltoluene.

[0035] When an electric field is not applied to the liquid crystal molecules 210 stabilized by a polymer, the liquid crystal molecules 210 are randomly aligned. In addition, when an electric field is applied to the liquid crystal molecules 210 stabilized by a polymer, the liquid crystal molecules 210 are aligned along the electric field. As a result, the blue phase

liquid crystal layer **200** of an isotropic polar material has a refractive index proportional to a square of a driving voltage, which is referred to as a Kerr effect, and a response speed of the blue phase mode LCD device **100** is improved due to the Kerr effect.

[0036] The refractive index of the blue phase liquid crystal layer **200** is determined according to regions where an electric field is generated. Accordingly, when an electric field is uniformly generated, uniformity in brightness is obtained and display property of the blue phase mode LCD device **100** is improved. Further, since an alignment step for the blue phase liquid crystal layer **200** is not required, an orientation film and a rubbing step are omitted.

[0037] Therefore, when the blue phase liquid crystal molecules **210** stabilized by a monomer is used for the liquid crystal layer **200**, the liquid crystal layer **200** is dynamically rotated according to an electric field and a response time of the blue phase mode LCD device **100** is reduced. In addition, a display property of the blue phase mode LCD device **100** is improved and an efficiency of fabrication is improved due to omission of an orientation film and a rubbing step.

[0038] The liquid crystal molecules **210** have an optically isotropic without a horizontal electric field due to a driving voltage and have a birefringence with a horizontal electric field due to a driving voltage. Accordingly, the optic properties of the blue phase liquid crystal layer **200** are adjusted by a horizontal electric field generated between electrodes. As a result, the blue phase mode LCD device **100** may include a pixel electrode and a common electrode formed on the same substrate so that a horizontal electric field can be generated between the pixel electrode and the common electrode. In addition, first and second polarizing plates have first and second polarization axes, respectively, perpendicular to each other.

[0039] Referring again to FIG. 1, a gate line (not shown), a gate electrode **121** connected to the gate line and a common line (not shown) parallel to and spaced apart from the gate line are formed on an inner surface of the first substrate **101**. A gate insulating layer **123** is formed on the gate line, the gate electrode **121** and the common line. A semiconductor layer **125** is formed on the gate insulating layer **123** over the gate electrode **121**, and source and drain electrodes **127** and **129** are formed on the semiconductor layer **125**. The semiconductor layer **125** may include an active layer **125a** of intrinsic amorphous silicon and an ohmic contact layer **125b** of impurity-doped amorphous silicon. In addition, a data line (not shown) connected to the source electrode **127** is formed on the gate insulating layer **123**. The data line crosses the gate line to define a pixel region P. The gate electrode **121**, the semiconductor layer **125**, the source electrode **127** and the drain electrode **129** constitute a thin film transistor (TFT) Tr.

[0040] A passivation layer **128** is formed on the TFT Tr, and a plurality of pixel electrodes **140** are formed over the passivation layer **128** in each pixel region P. The passivation layer **128** includes a drain contact hole **126** exposing the drain electrode **129**, and the plurality of pixel electrodes **140** are connected to the drain electrode **129** through the drain contact hole **126**. Further, a plurality of common electrodes **150** connected to the common line are formed over the passivation layer **128** in each pixel region P. The plurality of pixel electrodes **140** have the same material and the same layer as the plurality of common electrodes **150**. In addition, the plurality of pixel electrodes **140** are alternately disposed with the plurality of common electrodes **150**.

[0041] Specifically, an insulating pattern **300** is formed between each of the plurality of pixel electrodes **140** and the plurality of common electrodes **150** and the passivation layer **128**. The insulating pattern **300** may be formed of an organic insulating material such as benzocyclobutene (BCB) and acrylic resin. The plurality of pixel electrodes **140** and the plurality of common electrodes **150** have a height corresponding to a middle portion of the blue phase liquid crystal layer **200** due to the insulating pattern **300**. As a result, a horizontal electric field generated between the pixel electrode **140** and the common electrode **150** is strengthened.

[0042] A black matrix **131** having openings is formed on an inner surface of the second substrate **102** and a color filter layer **133** is formed on the black matrix **131**. The color filter layer **133** includes red, green and blue color filters corresponding to the openings of the black matrix **131**. An overcoat layer **135** is formed on the color filter layer **133**.

[0043] In the blue phase mode LCD device **100**, the plurality of pixel electrodes **140** and the plurality of common electrodes **150** are formed on the first substrate **101**, and the liquid crystal molecules **210** in the blue phase liquid crystal layer **200** are re-aligned along the horizontal electric field generated between the pixel electrode **140** and the common electrode **150**, thereby images displayed.

[0044] FIGS. 3A and 3B are cross-sectional views showing OFF and ON states, respectively, of a blue phase mode liquid crystal display device according to a first embodiment of the present invention.

[0045] In FIGS. 3A and 3B, a blue phase mode liquid crystal display (LCD) device **100** includes a liquid crystal panel and a backlight unit (not shown) supplying light to the liquid crystal panel. The liquid crystal panel includes first and second substrates **101** and **102** facing and spaced apart from each other and a blue phase liquid crystal layer **200** between the first and second substrates **101** and **102**. A pixel electrode **140** and a common electrode **150** are formed on an inner surface of the first substrate **101**. An insulating pattern **300** (of FIG. 1) under each of the pixel electrode **140** and the common electrode **150** is omitted in FIGS. 3A and 3B for illustrating a driving principle. In addition, a first polarizing plate **120** is formed on an outer surface of the first substrate **101**, and a second polarizing plate **130** is formed on an outer surface of the second substrate **102**.

[0046] Since liquid crystal molecules **210** in the blue phase liquid crystal layer **200** are re-aligned along a horizontal electric field parallel to the first and second substrates **101** and **102** to have a birefringence, the first and second polarizing plates **120** and **130** are formed for obtaining a maximum brightness such that a first polarization axis of the first polarizing plate **120** is perpendicular to a second polarization axis of the second polarizing plate **130**. In addition, each of the first and second polarization axes may form an angle of about 45° with respect to the horizontal electric field.

[0047] In FIG. 3A, the light from the backlight unit is linearly polarized along the first polarization axis through the first polarizing plate **120**. In an OFF state where no voltage is applied and no horizontal electric field is generated, a plurality of DTCs **220** (of FIG. 2) are arranged in a cubic lattice **230** (of FIG. 2). As a result, each liquid crystal molecule has a spherical shape and is optically isotropic. ($n_x = n_y$) The linearly polarized light passes through the blue phase liquid crystal layer **200** without change in polarization direction, and the linearly polarized light is completely absorbed to the second

polarizing plate 120. Accordingly, the blue phase mode LCD device 100 displays a black image.

[0048] In FIG. 3B, the light from the backlight unit is linearly polarized along the first polarization axis through the first polarizing plate 120. In an ON state where a voltage is applied to the pixel electrode 140 and the common electrode 150 and a horizontal electric field is generated between the pixel electrode 140 and the common electrode 150, the cubic lattice 230 of the plurality of DTCs 220 is distorted and a birefringence is induced in the liquid crystal molecules 210. As a result, each liquid crystal molecule 210 has an elliptical shape perpendicular to the horizontal electric field and is optically anisotropic. ($n_x > n_y$)

[0049] While the linearly polarized light passes through the blue phase liquid crystal layer 200, a component of the linearly polarized light parallel to director of the liquid crystal molecules 210 is transmitted to the second polarizing plate 130 and the other component is absorbed to the blue phase liquid crystal layer 200. In addition, a component of the transmitted light parallel to the second polarization axis passes through the second polarizing plate 130 and the other component is absorbed to the second polarizing plate 130. Accordingly, the blue phase mode LCD device 100 displays a white image.

[0050] In the blue phase mode LCD device 100, the cubic lattice 230 is distorted by the horizontal electric field and a white image is displayed by using the birefringence of the blue phase liquid crystal layer 200. The birefringence is proportional to the electric field. In addition, since the blue phase liquid crystal layer 200 has a cubic lattice 230 of the plurality of DTCs 220, an electric field of several tens V/ μm is required for driving the liquid crystal molecules 210. To increase the electric field, a distance between the pixel electrode 140 and the common electrode 150 may be reduced.

[0051] FIG. 4 is a graph showing a luminance change according to a voltage applied to a pixel electrode and a common electrode in a blue phase mode liquid crystal display device according to a first embodiment of the present invention.

[0052] In FIG. 4, a luminance has a maximum value at a voltage of about 80 V when a pixel electrode and a common electrode are spaced apart from each other by a first distance of about 9 μm , while a luminance has a maximum value at a voltage of about 60 V when a pixel electrode and a common electrode are spaced apart from each other by a second distance of about 4 μm . Accordingly, as a pixel electrode and a common electrode are closer to each other, a liquid crystal layer is driven by a smaller driving voltage. In addition, as the pixel electrode 140 is closer to the common electrode 150, a stronger electric field is applied to the blue phase liquid crystal layer 200.

[0053] However, as a pixel electrode and a common electrode are closer to each other, the luminance is reduced. The reduction of the luminance causes the reduction of the aperture ratio. To generate a stronger horizontal electric field without reduction of aperture ratio, the pixel electrode 140 and the common electrode 150 are formed to have a height corresponding to a middle portion of the blue phase liquid crystal layer 200.

[0054] FIG. 5A is a cross-sectional view showing a pixel electrode and a common electrode of a blue phase mode liquid crystal display device according to a first embodiment of the present invention, and FIG. 5B is a cross-sectional view showing a pixel electrode and a common electrode of a blue

phase mode liquid crystal display device according to a second embodiment of the present invention.

[0055] In FIG. 5A, a blue phase mode liquid crystal display (LCD) device 100 includes first and second substrates 101 and 102 facing and spaced apart from each other and a blue phase liquid crystal layer 200 between the first and second substrates 101 and 102. A plurality of insulating patterns 300 each having a relatively great thickness are formed on an inner surface of the first substrate 101. In addition, a plurality of pixel electrodes 140 and a plurality of common electrodes 150 are formed on the plurality of insulating patterns 300. Here, each of the plurality of pixel electrodes 140 and the plurality of common electrodes 150 is formed to cover a top surface of each of the plurality of insulating patterns 300 and expose a side surface of each of the plurality of insulating patterns 300. The plurality of pixel electrodes 140 are disposed alternately with the plurality of common electrodes 150 in each pixel region.

[0056] Each of the plurality of pixel electrodes 140 and the plurality of common electrodes 150 has a height corresponding to a middle portion of the blue phase liquid crystal layer 200 from the inner surface of the first substrate 101 due to the plurality of insulating patterns 300. For example, when the first and second substrates 101 and 102 are spaced apart from each other by a distance of about 10 μm (i.e., a cell gap of the blue phase mode LCD device 100 has a cell gap of about 10 μm), the plurality of insulating patterns 300 may have a thickness of about 1 μm to about 9 μm (i.e., a bottom surface of each of the plurality of pixel electrodes 140 and the plurality of common electrodes 150 may have a height of about 1 μm to about 9 μm).

[0057] When a driving voltage is applied to the plurality of pixel electrodes 140 and the plurality of common electrodes 150, a horizontal electric field is generated between the adjacent pixel and common electrodes 140 and 150. The dashed line of FIG. 5A shows an equipotential surface. As the height of the plurality of pixel electrodes 140 and the plurality of common electrodes 150 increases due to the plurality of insulating patterns 300, the equipotential surface is induced along a direction closer to a vertical direction. Since a direction of an electric field is perpendicular to the equipotential surface, the horizontal electric field is generated along a direction closer to a horizontal direction as compared with the horizontal electric field generated without the plurality of insulating patterns 300. As a result, a stronger horizontal electric field is generated in the blue phase liquid crystal layer 200 and the blue phase mode LCD device 100 is operated with a lower driving voltage.

[0058] In FIG. 5B, a blue phase mode liquid crystal display (LCD) device 105 includes first and second substrates 106 and 107 facing and spaced apart from each other and a blue phase liquid crystal layer 205 between the first and second substrates 106 and 107. A plurality of insulating patterns 305 each having a relatively great thickness are formed on an inner surface of the first substrate 106. In addition, a plurality of pixel electrodes 145 and a plurality of common electrodes 155 are formed on the plurality of insulating patterns 305. Here, each of the plurality of pixel electrodes 145 and the plurality of common electrodes 155 is formed to cover a side surface and a top surface of each of the plurality of insulating patterns 305. The plurality of pixel electrodes 145 are disposed alternately with the plurality of common electrodes 155 in each pixel region.

[0059] Each of the plurality of pixel electrodes **145** and the plurality of common electrodes **155** has a height corresponding to a middle portion or an upper portion of the blue phase liquid crystal layer **205** from the inner surface of the first substrate **106** due to the plurality of insulating patterns **305**. For example, when the first and second substrates **106** and **107** are spaced apart from each other by a distance of about 10 μm (i.e., a cell gap of the blue phase mode LCD device **105** has a cell gap of about 10 μm), the plurality of insulating patterns **305** may have a thickness of about 1 μm to about 10 μm (i.e., a bottom surface of each of the plurality of pixel electrodes **145** and the plurality of common electrodes **155** may have a height of about 1 μm to about 10 μm).

[0060] When a driving voltage is applied to the plurality of pixel electrodes **145** and the plurality of common electrodes **155**, a horizontal electric field is generated between the adjacent pixel and common electrodes **145** and **155**. Since each of the plurality of pixel electrodes **145** and the plurality of common electrodes **155** is formed on the top and side surfaces of each of the plurality of insulating patterns **305**, the horizontal electric field is generated between portions of the adjacent pixel and common electrodes **145** and **155** on the side surface of each insulating pattern **305** as well as between portions of the adjacent pixel and common electrodes **145** and **155** on the top surface of each insulating pattern **305**. The dashed line of FIG. 5B shows an equipotential surface. As the height of the plurality of pixel electrodes **145** and the plurality of common electrodes **155** increases due to the plurality of insulating patterns **305**, the equipotential surface is induced along a direction closer to a vertical direction. In addition, the equipotential surface is induced along a direction further closer to a vertical direction due to portions of the adjacent pixel and common electrodes **145** and **155** on the side surface of each insulating pattern **305**. Since a direction of an electric field is perpendicular to the equipotential surface, the horizontal electric field is generated along a direction further closer to a horizontal direction as compared with the horizontal electric field generated only between portions of the adjacent pixel and common electrodes **145** and **155** on the top surface of each insulating pattern **305**. As a result, a stronger and more uniform horizontal electric field is generated in the whole blue phase liquid crystal layer **205** and the blue phase mode LCD device **105** is operated with a lower driving voltage.

[0061] Specifically, since the horizontal electric field is generated between portions of the adjacent pixel and common electrodes **145** and **155** on the side surface of each insulating pattern **305**, each insulating pattern **305** may have a thickness corresponding to the cell gap such that each of the pixel electrode **145** and the common electrode **155** contacts the second substrate **107** (substantially an overcoat layer **135** on an inner surface of the second substrate **102** of FIG. 1). For example, each insulating pattern **305** may have a thickness of about 10 μm in the blue phase mode LCD device **105** having a cell gap of about μm . When each insulating pattern **305** contacts the second substrate **107**, each insulating pattern **305** may function as a patterned spacer maintaining the cell gap.

[0062] FIG. 6 is a graph showing a transmittance change according to a voltage applied to a pixel electrode and a common electrode in blue phase mode liquid crystal display devices according to first and second embodiments of the present invention.

[0063] In FIG. 6, a transmittance change is measured for four blue phase liquid crystal display (LCD) devices. In a first blue phase mode LCD device, an insulating pattern is omitted

and each of a pixel electrode and a common electrode has a thickness of about 0.2 μm to about 0.3 μm such that a top surface of each of the pixel electrode and the common electrode has a reference height of about 0.2 μm to about 0.3 μm with respect to an inner surface of a first substrate. In a second blue phase mode LCD device according to a first embodiment of the present invention, an insulating pattern has a thickness of about 2.4 μm and each of a pixel electrode and a common electrode covering a top surface of the insulating pattern has a thickness of about 0.2 μm to about 0.3 μm such that a top surface of each of the pixel electrode and the common electrode has a first height of about 2.6 μm to about 2.7 μm with respect to an inner surface of a first substrate. In a third blue phase mode LCD device according to a second embodiment of the present invention, an insulating pattern has a thickness of about 1.0 μm and each of a pixel electrode and a common electrode covering top and side surfaces of the insulating pattern has a thickness of about 0.2 μm to about 0.3 μm such that a top surface of each of the pixel electrode and the common electrode has a second height of about 1.2 μm to about 1.3 μm with respect to an inner surface of a first substrate. Finally, in a fourth blue phase mode LCD device according to a second embodiment of the present invention, an insulating pattern has a thickness of about 2.4 μm and each of a pixel electrode and a common electrode covering top and side surfaces of the insulating pattern has a thickness of about 0.2 μm to about 0.3 μm such that a top surface of each of the pixel electrode and the common electrode has the first height of about 2.6 μm to about 2.7 μm with respect to an inner surface of a first substrate.

[0064] The transmittance of the first blue phase mode LCD device corresponding to the reference height has a maximum value at a voltage of about 74 V, and the transmittance of the second blue phase LCD device corresponding to the first height has a maximum value at a voltage of about 68 V. In addition, the transmittance of the third blue phase LCD device corresponding to the second height has a maximum value at a voltage of about 58 V, and the transmittance of the fourth blue phase LCD device corresponding to the first height has a maximum value at a voltage of about 44 V.

[0065] Accordingly, a driving voltage is reduced without reduction of transmittance by forming each of a pixel electrode and a common electrode on an insulating pattern in a blue phase mode LCD device according to a first embodiment of the present invention, and a driving voltage is further reduced without reduction of transmittance by forming each of a pixel electrode and a common electrode on top and side surfaces of an insulating pattern in a blue phase mode LCD device according to a second embodiment of the present invention.

[0066] FIGS. 7A to 7C are cross-sectional views showing a method of fabricating an array substrate for a blue phase mode liquid crystal display device according to a first embodiment of the present invention.

[0067] In FIG. 7A, a gate line (not shown), a gate electrode **121** and a common line (not shown) are formed on a first substrate **101** by depositing and patterning a first metallic material. The gate electrode **121** is connected to the gate line, and the common line is parallel to and spaced apart from the gate line. The first metallic material may include one of aluminum (Al), aluminum (Al) alloy, chromium (Cr), molybdenum (Mo), tungsten (W) and copper (Cu). A gate insulating layer **123** is formed on the gate line, the gate electrode **121** and the common line by depositing an inorganic insulating mate-

rial. The inorganic insulating material may include one of silicon nitride (SiNx) and silicon oxide (SiO₂). An active layer **125a** and an ohmic contact layer **125b** are sequentially formed on the gate insulating layer **123** over the gate electrode **121** by depositing and patterning intrinsic amorphous silicon (a-Si:H) and impurity-doped amorphous silicon (n+a-Si:H). The active layer **125a** and the ohmic contact layer **125b** constitute a semiconductor layer **125**.

[0068] A source electrode **127** and a drain electrode **129** are formed on the ohmic contact layer **125b** by depositing and patterning a second metallic material. Simultaneously, a data line (not shown) is formed on the gate insulating layer **123**. The source electrode **127** is connected to the data line, and the drain electrode **129** is spaced apart from the source electrode **127**. The data line crosses the gate line to define a pixel region P. The second metallic material may include one of aluminum (Al), aluminum (Al) alloy, chromium (Cr), molybdenum (Mo), tungsten (W) and copper (Cu). The gate electrode **121**, the gate insulating layer **123**, the semiconductor layer **125**, the source electrode **127** and the drain electrode **129** constitute a thin film transistor (TFT) Tr. In addition, a passivation layer **128** is formed on the TFT Tr by depositing one of an inorganic insulating material and an organic insulating material. The passivation layer **128** includes a drain contact hole **126** exposing the drain electrode **129** and a common contact hole (not shown) exposing the common line.

[0069] In FIG. 7B, a plurality of insulating patterns **300** are formed on the passivation layer **128** by depositing and patterning an organic insulating material. The organic insulating material may include one of benzocyclobutene (BCB) and acrylic resin. The plurality of insulating patterns **300** may be formed through a mask process. For example, after an organic insulating material layer is formed on the passivation layer **128**, a photoresist layer is formed on the organic insulating material layer. After a photo mask is disposed over the photoresist layer, light is irradiated onto the photoresist layer through the photo mask to form a photoresist pattern. In addition, after the organic insulating material layer is patterned using the photoresist pattern as an etching mask to form the plurality of insulating patterns **300**, the photoresist pattern is removed through an ashing step or a stripping step.

[0070] In FIG. 7C, a plurality of pixel electrodes **140** and a plurality of common electrodes **150** are formed on the passivation layer **128** and the plurality of insulating patterns **300** by depositing and patterning a transparent conductive material. The transparent conductive material may include one of indium-tin-oxide (ITO) and indium-zinc-oxide (IZO). The plurality of pixel electrodes **140** connected to each other is connected to the drain electrode **129** through the drain contact hole **126**, and the plurality of common electrodes **150** connected to each other is connected to the common line through the common contact hole. The plurality of pixel electrodes **140** are alternately disposed with the plurality of common electrodes **150** in the pixel region. Although each of the plurality of pixel electrodes **140** and the plurality of common electrodes **150** is formed on a top surface of each of the plurality of insulating patterns **300** and a side surface of each of the plurality of insulating patterns **300** is exposed in the first embodiment, the plurality of pixel electrodes and the plurality of common electrodes may be formed to cover top and side surfaces of each of the plurality of insulating patterns in the second embodiment.

[0071] Further, after an array substrate is completed, a color filter substrate including a black matrix **131** (of FIG. 1) and a

color filter layer **133** (of FIG. 1) is attached to the array substrate and a blue phase liquid crystal layer **200** (of FIG. 1) is formed between the array substrate and the color filter substrate. As a result, a blue phase mode LCD device **100** (of FIG. 1) according to a first embodiment of the present invention is completed. Since each of the plurality of pixel electrodes **140** and the plurality of common electrodes **150** is formed on each of the plurality of insulating patterns **300**, each of the plurality of pixel electrodes **140** and the plurality of common electrodes **150** is disposed in a middle portion of the blue phase liquid crystal and a horizontal electric field is strengthened. Accordingly, a driving voltage for the blue phase mode LCD device **100** is reduced without reduction in transmittance and aperture ratio.

[0072] The structure of the pixel electrode and the common electrode may be applied to a uniform standing helix (USH) mode liquid crystal display device.

[0073] FIGS. 8A and 8B are side views showing an OFF state and an ON state, respectively, of a uniform standing helix liquid crystal layer for a liquid crystal display device according to a third embodiment of the present invention.

[0074] In FIGS. 8A and 8B, a uniform standing helix (USH) liquid crystal layer **400** includes chiral nematic liquid crystal molecules **410** having a helical structure where the chiral nematic liquid crystal molecules are twisted by several tens times along a helical axis. The chiral nematic liquid crystal molecules **410** having a short pitch are driven by using a flexoelectric effect. In FIG. 8A showing an OFF state of no driving voltage ($V=0$) (no horizontal electric field), an optic axis is parallel to the helix axis of the chiral nematic liquid crystal molecules **410**. In FIG. 8B showing an ON state of a driving voltage ($V \neq 0$) (a horizontal electric field), the optic axis rotates to cross the helical axis and the chiral nematic liquid crystal molecules **410** have a birefringence property.

[0075] FIGS. 9A and 9B are front views showing an OFF state and an ON state, respectively, of a uniform standing helix liquid crystal layer for a liquid crystal display device according to a third embodiment of the present invention.

[0076] In FIGS. 9A and 9B, a uniform standing helix (USH) liquid crystal layer includes bimesogen liquid crystal molecules **410** arranged to have a polarity and has a relatively high response speed.

[0077] In FIG. 9A showing an OFF state of no driving voltage ($V=0$) (no horizontal electric field), chiral nematic liquid crystal molecules (USH liquid crystal molecules) **410** having a short pitch are twisted by several tens times along a helical axis in the USH liquid crystal layer **400** (of FIG. 8A) and the helical axis is parallel to an optic axis (z direction) which may be defined as a propagation direction of light. Accordingly, refractive indices of the USH liquid crystal layer along x and y directions perpendicular to the z direction are the same as each other at a front viewing angle. ($n_x = n_y$) As a result, the USH liquid crystal layer has an optically isotropic state at the front viewing angle.

[0078] In FIG. 9B showing an ON state of a driving voltage ($V \neq 0$) (a horizontal electric field), the chiral nematic liquid crystal molecules (USH liquid crystal molecules) **410** are re-aligned according to an electric field having a direction (x or y direction) perpendicular to the optic axis and the helical structure is distorted. As a result, the optic axis rotates to cross the helical axis and the chiral nematic liquid crystal molecules **410** have a birefringence property.

[0079] Similarly to the blue phase liquid crystal layer **200** (of FIG. 1), the optical properties of the USH liquid crystal

layer 400 are adjusted by a horizontal electric field generated between electrodes. As a result, a USH mode LCD device may include a pixel electrode and a common electrode formed on the same substrate so that a horizontal electric field can be generated between the pixel electrode and the common electrode. In addition, first and second polarizing plates have first and second polarization axes, respectively, perpendicular to each other.

[0080] Since the chiral nematic liquid crystal molecules 410 in the USH liquid crystal layer 400 are re-aligned along a horizontal electric field parallel to a substrate to have a birefringence, the first and second polarizing plates are formed for obtaining a maximum brightness such that the first polarization axis of the first polarizing plate is perpendicular to the second polarization axis of the second polarizing plate. In addition, each of the first and second polarization axes may form an angle of about 45° with respect to the horizontal electric field. As a result, when no voltage is applied, the birefringence is not induced and the USH mode LCD device displays a black image. Further, when a voltage is applied, the birefringence is induced and the USH mode LCD device displays grey images with a relative high response speed.

[0081] However, the USH mode LCD device has a disadvantage of a relatively high driving voltage similarly to the blue phase LCD device. To reduce a driving voltage, the pixel electrode and the common electrode may be formed to have a height corresponding to a middle portion of the USH liquid crystal layer 400.

[0082] FIG. 10A is a cross-sectional view showing a pixel electrode and a common electrode of a uniform standing helix mode liquid crystal display device according to a second embodiment of the present invention, and FIG. 10B is a cross-sectional view showing a pixel electrode and a common electrode of a uniform standing helix mode liquid crystal display device according to a fourth embodiment of the present invention.

[0083] In FIG. 10A, a uniform standing helix (USH) mode liquid crystal display (LCD) device 500 includes first and second substrates 401 and 402 facing and spaced apart from each other and a USH liquid crystal layer 400 between the first and second substrates 401 and 402. A plurality of insulating patterns 600 each having a relatively great thickness are formed on an inner surface of the first substrate 401. In addition, a plurality of pixel electrodes 440 and a plurality of common electrodes 450 are formed on the plurality of insulating patterns 600. Here, each of the plurality of pixel electrodes 440 and the plurality of common electrodes 450 is formed to cover a top surface of each of the plurality of insulating patterns 600 and expose a side surface of each of the plurality of insulating patterns 600. The plurality of pixel electrodes 440 are disposed alternately with the plurality of common electrodes 450 in each pixel region.

[0084] Each of the plurality of pixel electrodes 440 and the plurality of common electrodes 450 has a height corresponding to a middle portion of the USH liquid crystal layer 400 from the inner surface of the first substrate 401 due to the plurality of insulating patterns 600. For example, when the first and second substrates 401 and 402 are spaced apart from each other by a distance of about 10 μm (i.e., a cell gap of the USH mode LCD device 500 has a cell gap of about 10 μm), the plurality of insulating patterns 600 may have a thickness of about 1 μm to about 9 μm (i.e., a bottom surface of each of

the plurality of pixel electrodes 440 and the plurality of common electrodes 450 may have a height of about 1 μm to about 9 μm).

[0085] When a driving voltage is applied to the plurality of pixel electrodes 440 and the plurality of common electrodes 450, a horizontal electric field is generated between the adjacent pixel and common electrodes 440 and 450. The dashed line of FIG. 10A shows an equipotential surface. As the height of the plurality of pixel electrodes 440 and the plurality of common electrodes 450 increases due to the plurality of insulating patterns 600, the equipotential surface is induced along a direction closer to a vertical direction. Since a direction of an electric field is perpendicular to the equipotential surface, the horizontal electric field is generated along a direction closer to a horizontal direction as compared with the horizontal electric field generated without the plurality of insulating patterns 600. As a result, a stronger horizontal electric field is generated in the USH liquid crystal layer 400 and the USH mode LCD device 500 is operated with a lower driving voltage.

[0086] In FIG. 10B, a uniform standing helix (USH) mode liquid crystal display (LCD) device 505 includes first and second substrates 406 and 407 facing and spaced apart from each other and a USH liquid crystal layer 405 between the first and second substrates 406 and 407. A plurality of insulating patterns 605 each having a relatively great thickness are formed on an inner surface of the first substrate 406. In addition, a plurality of pixel electrodes 445 and a plurality of common electrodes 455 are formed on the plurality of insulating patterns 605. Here, each of the plurality of pixel electrodes 445 and the plurality of common electrodes 455 is formed to cover a side surface and a top surface of each of the plurality of insulating patterns 605. The plurality of pixel electrodes 445 are disposed alternately with the plurality of common electrodes 455 in each pixel region.

[0087] Each of the plurality of pixel electrodes 445 and the plurality of common electrodes 455 has a height corresponding to a middle portion or an upper portion of the USH liquid crystal layer 405 from the inner surface of the first substrate 406 due to the plurality of insulating patterns 605. For example, when the first and second substrates 406 and 407 are spaced apart from each other by a distance of about 10 μm (i.e., a cell gap of the USH mode LCD device 505 has a cell gap of about 10 μm), the plurality of insulating patterns 605 may have a thickness of about 1 μm to about 10 μm (i.e., a bottom surface of each of the plurality of pixel electrodes 445 and the plurality of common electrodes 455 may have a height of about 1 μm to about 10 μm).

[0088] When a driving voltage is applied to the plurality of pixel electrodes 445 and the plurality of common electrodes 455, a horizontal electric field is generated between the adjacent pixel and common electrodes 445 and 455. Since each of the plurality of pixel electrodes 445 and the plurality of common electrodes 455 is formed on the top and side surfaces of each of the plurality of insulating patterns 605, the horizontal electric field is generated between portions of the adjacent pixel and common electrodes 445 and 455 on the side surface of each insulating pattern 605 as well as between portions of the adjacent pixel and common electrodes 445 and 455 on the top surface of each insulating pattern 605. The dashed line of FIG. 10B shows an equipotential surface. As the height of the plurality of pixel electrodes 445 and the plurality of common electrodes 455 increases due to the plurality of insulating patterns 605, the equipotential surface is induced along a

direction closer to a vertical direction. In addition, the equipotential surface is induced along a direction further closer to a vertical direction due to portions of the adjacent pixel and common electrodes **445** and **455** on the side surface of each insulating pattern **605**. Since a direction of an electric field is perpendicular to the equipotential surface, the horizontal electric field is generated along a direction further closer to a horizontal direction as compared with the horizontal electric field generated only between portions of the adjacent pixel and common electrodes **445** and **455** on the top surface of each insulating pattern **605**. As a result, a stronger and more uniform horizontal electric field is generated in the whole USH liquid crystal layer **405** and the USH mode LCD device **505** is operated with a lower driving voltage.

[0089] Specifically, since the horizontal electric field is generated between portions of the adjacent pixel and common electrodes **445** and **455** on the side surface of each insulating pattern **605**, each insulating pattern **605** may have a thickness corresponding to the cell gap such that each of the pixel electrode **445** and the common electrode **455** contacts the second substrate **407** (substantially an overcoat layer **135** on an inner surface of the second substrate **102** of FIG. 1). For example, each insulating pattern **605** may have a thickness of about 10 μm in the blue phase mode LCD device **505** having a cell gap of about μm . When each insulating pattern **605** contacts the second substrate **407**, each insulating pattern **605** may function as a patterned spacer maintaining the cell gap.

[0090] Consequently, in a liquid crystal display device according to the present invention, a horizontal electric field is strengthened and a driving voltage is reduced without reduction of transmittance and aperture ratio by forming each of pixel and common electrodes on an insulating pattern. Moreover, a horizontal electric field is further strengthened and a driving voltage is further reduced by forming each of pixel and common electrodes on top and side surfaces of an insulating pattern.

[0091] It will be apparent to those skilled in the art that various modifications and variations can be made in the liquid crystal display device of the present invention without departing from the spirit or scope of the invention. Thus, it is intended that the present invention covers the modifications and variations of this invention provided they come within the scope of the appended claims and their equivalents.

What is claimed is:

1. A liquid crystal display device, comprising:
 - first and second substrates facing and spaced apart from each other;
 - a plurality of insulating patterns on an inner surface of the first substrate;
 - a plurality of pixel electrodes and a plurality of common electrodes on the plurality of insulating patterns, the plurality of pixel electrodes alternating with the plurality of common electrodes, the adjacent pixel and common electrodes generating a horizontal electric field according to a driving voltage; and
 - a liquid crystal layer between the first and second substrates, the liquid crystal layer including one of a blue phase liquid crystal molecules and a uniform standing helix liquid crystal molecules.
2. The device according to claim 1, wherein the blue phase liquid crystal molecules have an optically isotropic state with-

out the horizontal electric field and have an optically anisotropic state having a birefringence with the horizontal electric field.

3. The device according to claim 1, wherein the uniform standing helix liquid crystal molecules have an optically isotropic state at a front viewing angle without the horizontal electric field and have a birefringence with the horizontal electric field.

4. The device according to claim 1, wherein each of the plurality of pixel electrodes and the plurality of common electrodes covers a top surface of each of the plurality of insulating patterns and a side surface of each of the plurality of insulating patterns is exposed.

5. The device according to claim 4, wherein the first and second substrates are spaced apart by a distance of about 10 μm and each of the plurality of insulating patterns has a thickness of about 1 μm to about 9 μm .

6. The device according to claim 1, wherein each of the plurality of pixel electrodes and the plurality of common electrodes covers top and side surfaces of each of the plurality of insulating patterns.

7. The device according to claim 6, wherein the first and second substrates are spaced apart by a distance of about 10 μm and each of the plurality of insulating patterns has a thickness of about 1 μm to about 10 μm .

8. The device according to claim 6, wherein each of the plurality of pixel electrodes and the plurality of common electrodes contacts the second substrate.

9. The device according to claim 1, wherein the plurality of pixel electrodes have a same material and a same layer as the plurality of common electrodes.

10. The device according to claim 1, wherein the plurality of insulating patterns include one of benzoocyclobutene (BCB) and acrylic resin.

11. The device according to claim 1, further comprising a first polarizing plate on an outer surface of the first substrate and a second polarizing plate on an outer surface of the second substrate, wherein the first and second polarizing plates have first and second polarization axes, respectively, perpendicular to each other.

12. The device according to claim 1, further comprising:

- a gate line, a data line and a common line over the inner surface of the first substrate, the gate line crossing the data line to define a pixel region, the common line parallel to the gate line; and
- a thin film transistor connected to the gate line and the data line.

13. The device according to claim 12, further comprising a passivation layer on the gate line, the data line, the common line and the thin film transistor, wherein the passivation layer includes a common contact hole exposing the common line and a drain contact hole exposing a drain electrode of the thin film transistor.

14. The device according to claim 13, wherein the plurality of common electrodes are connected to the common line through the common contact hole, and the plurality of pixel electrodes is connected to the drain electrode of the thin film transistor through the drain contact hole.

* * * * *

专利名称(译)	液晶显示装置		
公开(公告)号	US20110141421A1	公开(公告)日	2011-06-16
申请号	US12/946242	申请日	2010-11-15
[标]申请(专利权)人(译)	李相旭 PARK劲炫 WOO JONG HOON 尹东KYU LEE WOO瑾		
申请(专利权)人(译)	李相旭 朴贤金 WOO宗埙 尹东KYU 李禹瑾		
当前申请(专利权)人(译)	李相旭 朴贤金 WOO宗埙 尹东KYU 李禹瑾		
[标]发明人	LEE SANG WOOK PARK HYUN JIN WOO JONG HOON YOON DONG KYU LEE WOO KEUN		
发明人	LEE, SANG-WOOK PARK, HYUN-JIN WOO, JONG-HOON YOON, DONG-KYU LEE, WOO-KEUN		
IPC分类号	G02F1/1333		
CPC分类号	G02F1/134309 G02F1/134363 G02F2001/13793 G02F1/1418 G02F1/1393		
优先权	1020090123495 2009-12-11 KR		
其他公开文献	US8848156		
外部链接	Espacenet USPTO		

摘要(译)

一种液晶显示装置，包括：第一基板和第二基板，彼此面对并且彼此间隔开；在第一基板的内表面上的多个绝缘图案；所述多个绝缘图案上的多个像素电极和多个公共电极，所述多个像素电极与所述多个公共电极交替，所述相邻的像素和公共电极根据驱动电压产生水平电场；以及在第一和第二基板之间的液晶层，该液晶层包括蓝相液晶分子和均匀直立螺旋液晶分子中的一种。

