



US 20050099577A1

(19) **United States**

(12) **Patent Application Publication**

Lee et al.

(10) **Pub. No.: US 2005/0099577 A1**

(43) **Pub. Date: May 12, 2005**

(54) **SUBSTRATE, LIQUID CRYSTAL DISPLAY DEVICE, AND METHOD OF MANUFACTURING THE SAME**

Publication Classification

(51) **Int. Cl.⁷ G02F 1/1339**

(75) **Inventors: Woo-Shik Lee, Seoul (KR); Gi-Chun Yoo, Suwon-si (KR); Baek-Kyun Jeon, Yongin-si (KR)**

(52) **U.S. Cl. 349/155**

Correspondence Address:
**McGuire Woods
Suite 1800
1750 Tysons Boulevard
McLean, VA 22102-4215 (US)**

(57) **ABSTRACT**

A liquid crystal display apparatus includes first and second substrates, a fence, a liquid crystal layer and a plurality of spacers. The first substrate includes a display region for displaying an image. The second substrate faces the first substrate. The fence is disposed between the first substrate and the second substrate. The fence surrounds the display. The spacers maintain the distance between the first and second substrates. The spacers have a gradually increasing compression ratio in a direction from a center of the display region to an edge of the display region. The liquid crystal display apparatus maintains a uniform cell gap, even though a compressive stress of a center portion of the liquid crystal display apparatus is different with a compressive stress of an edge portion of the liquid crystal display apparatus. Therefore, display quality is enhanced.

(73) **Assignee: Samsung Electronics Co., Ltd.**

(21) **Appl. No.: 10/643,934**

(22) **Filed: Aug. 20, 2003**

(30) **Foreign Application Priority Data**

Aug. 21, 2002 (KR) 2002-49576
Oct. 4, 2002 (KR) 2002-60498
Oct. 30, 2002 (KR) 2002-66617

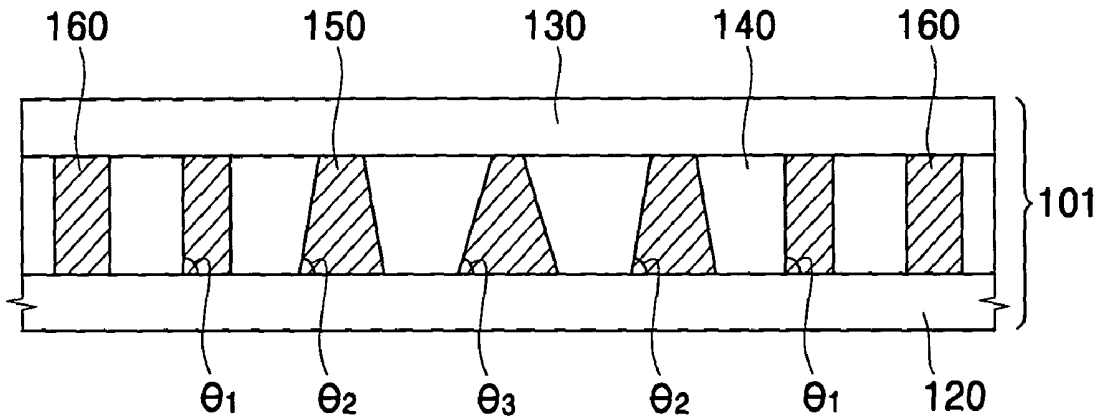

FIG. 1
(PRIOR ART)

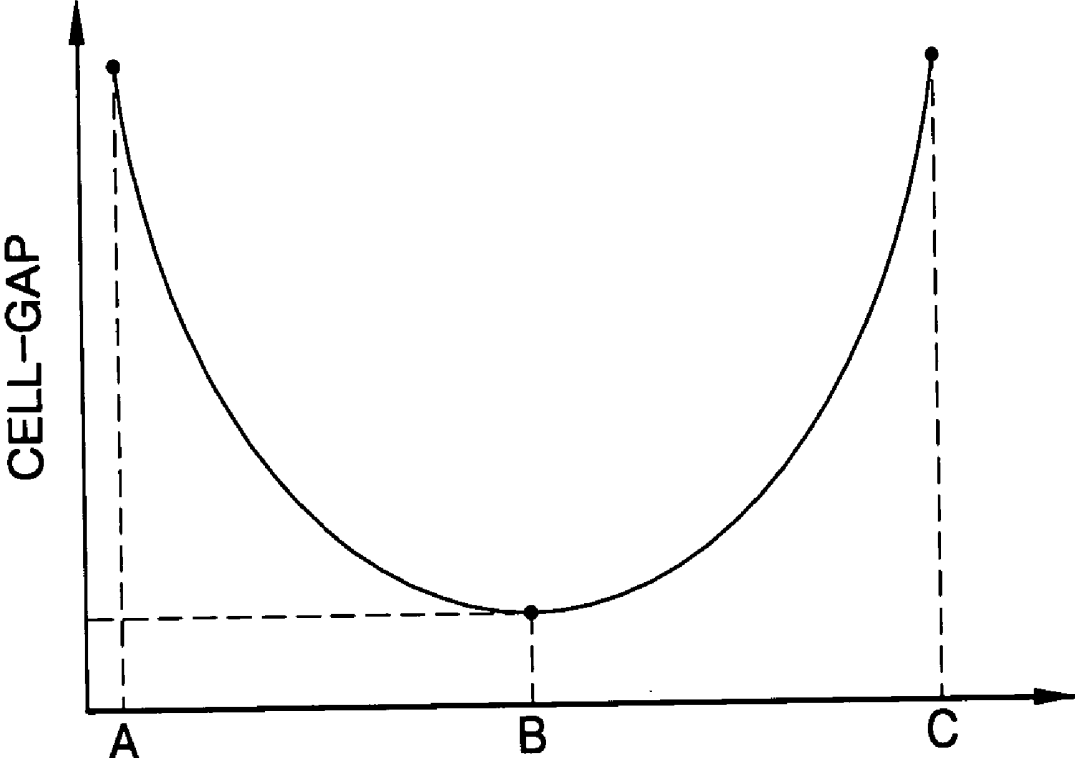

FIG. 2

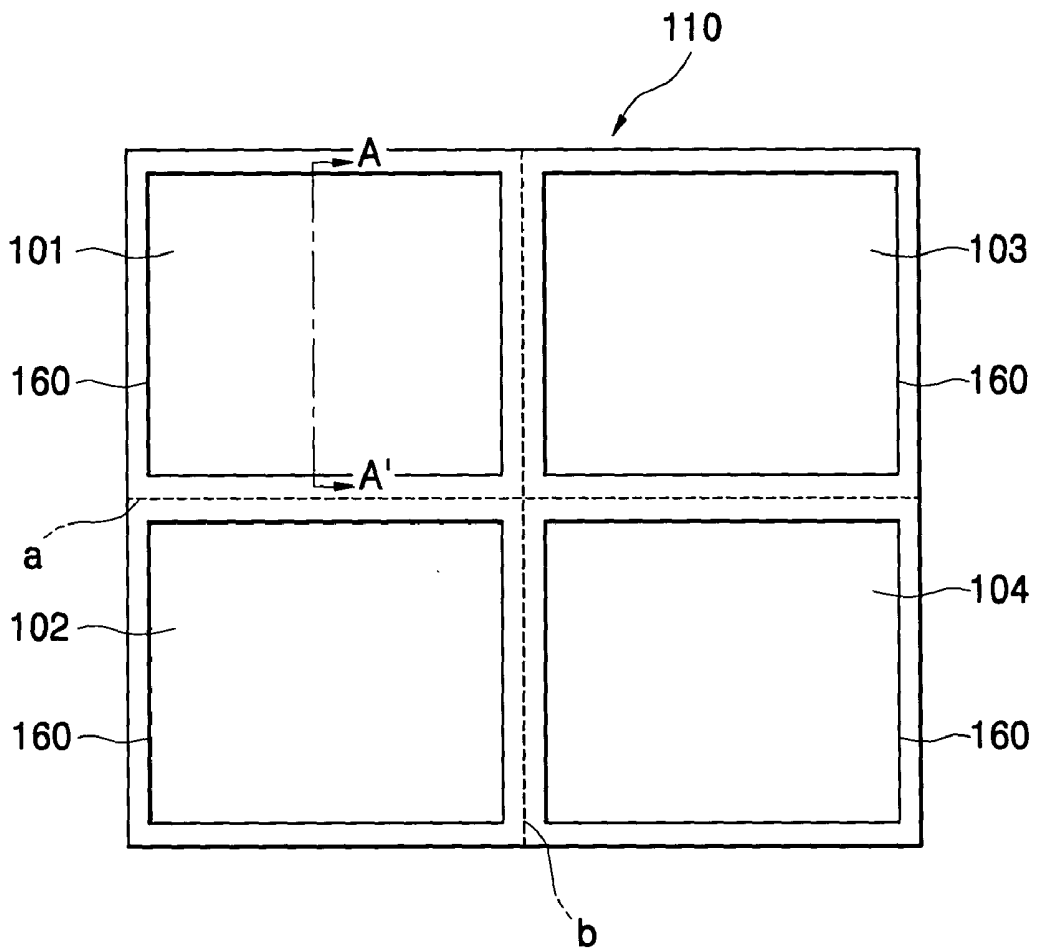

FIG. 3

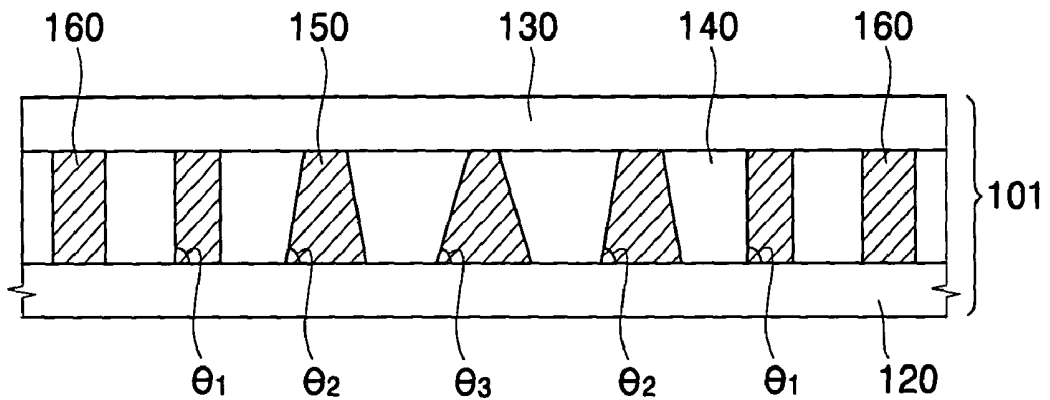

FIG. 4

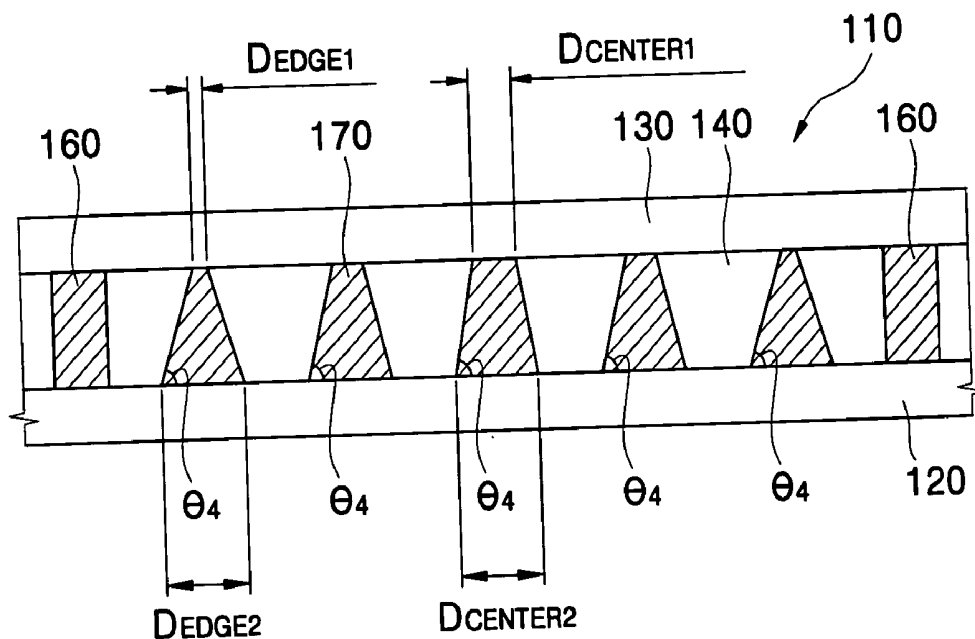

FIG. 5

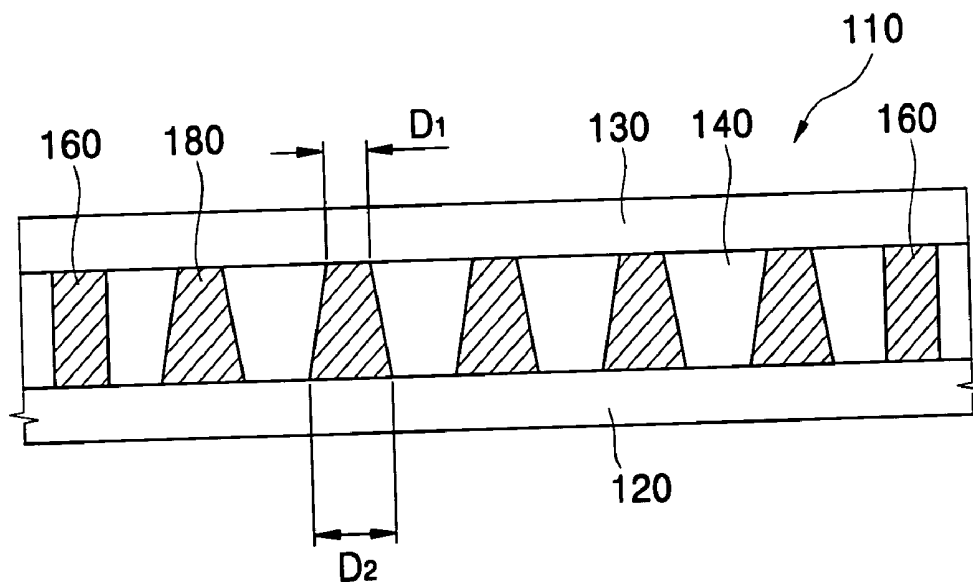

FIG. 6

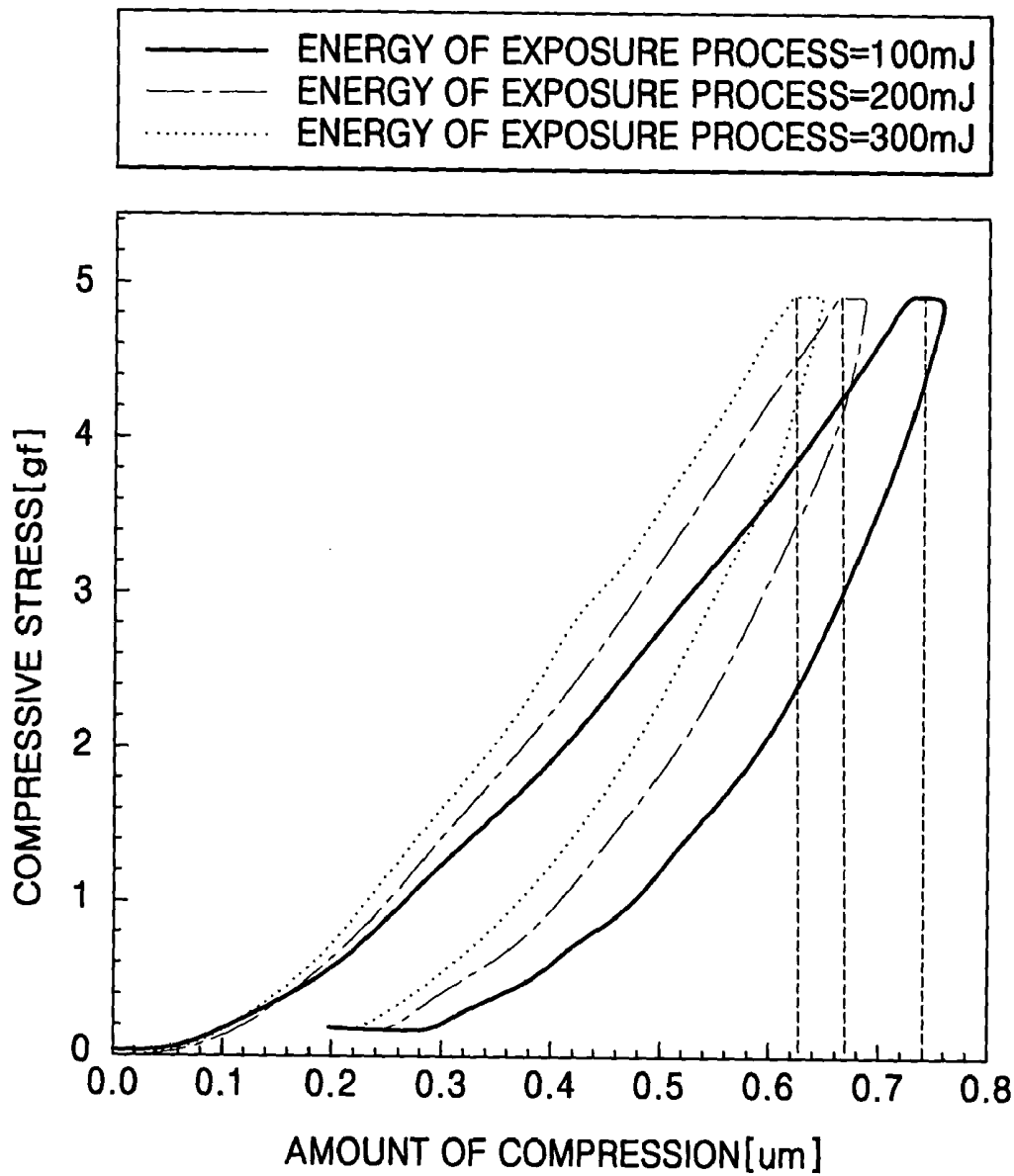

FIG. 7

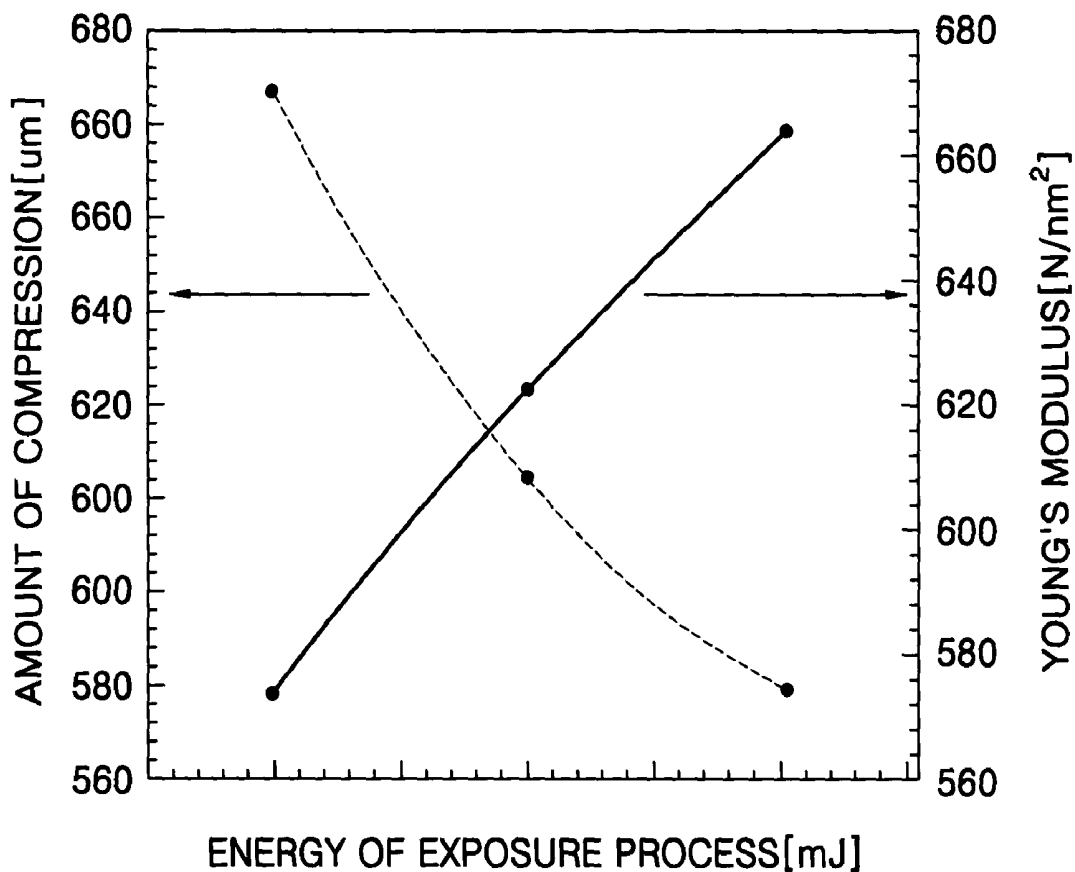

FIG. 8

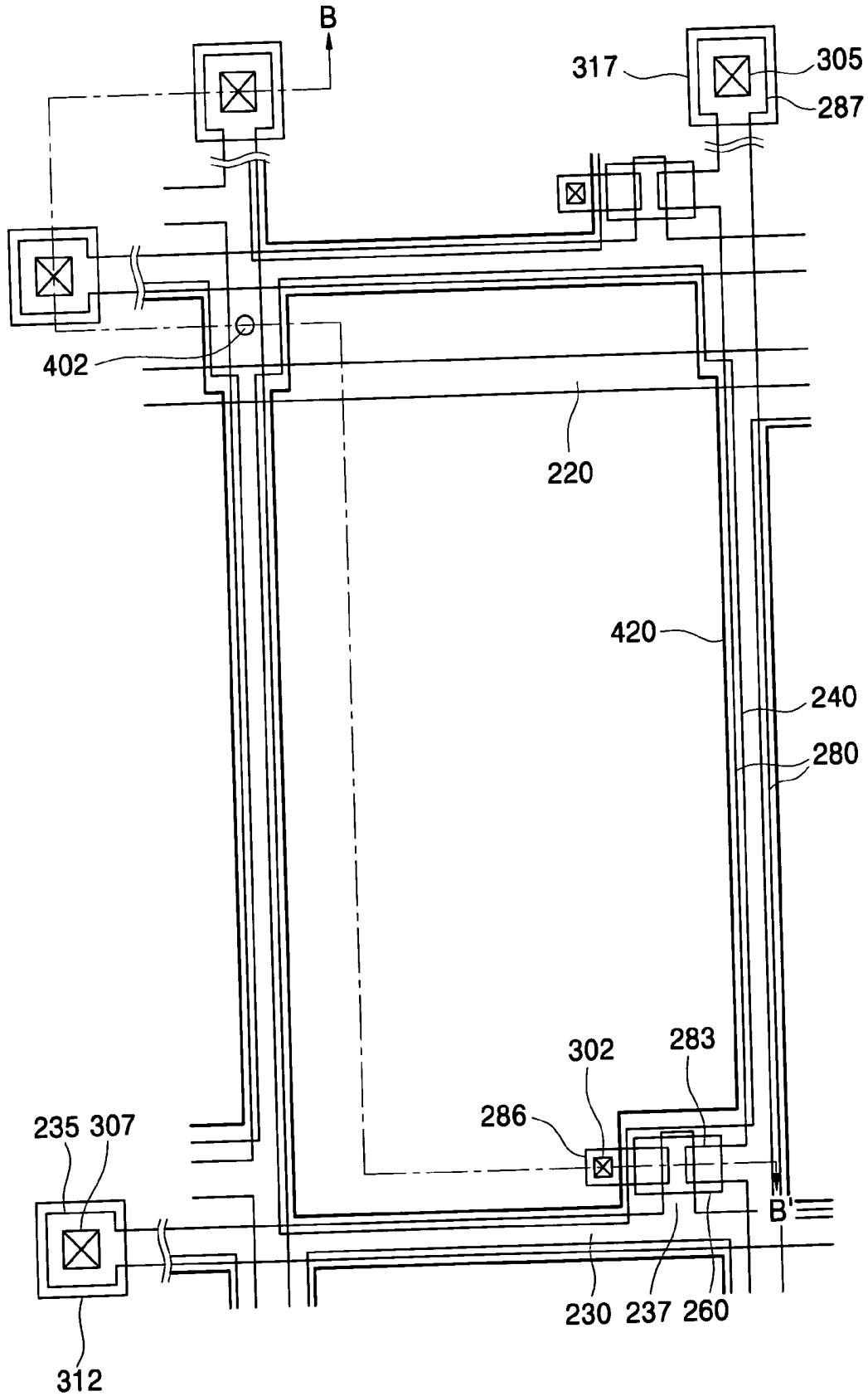

FIG. 9

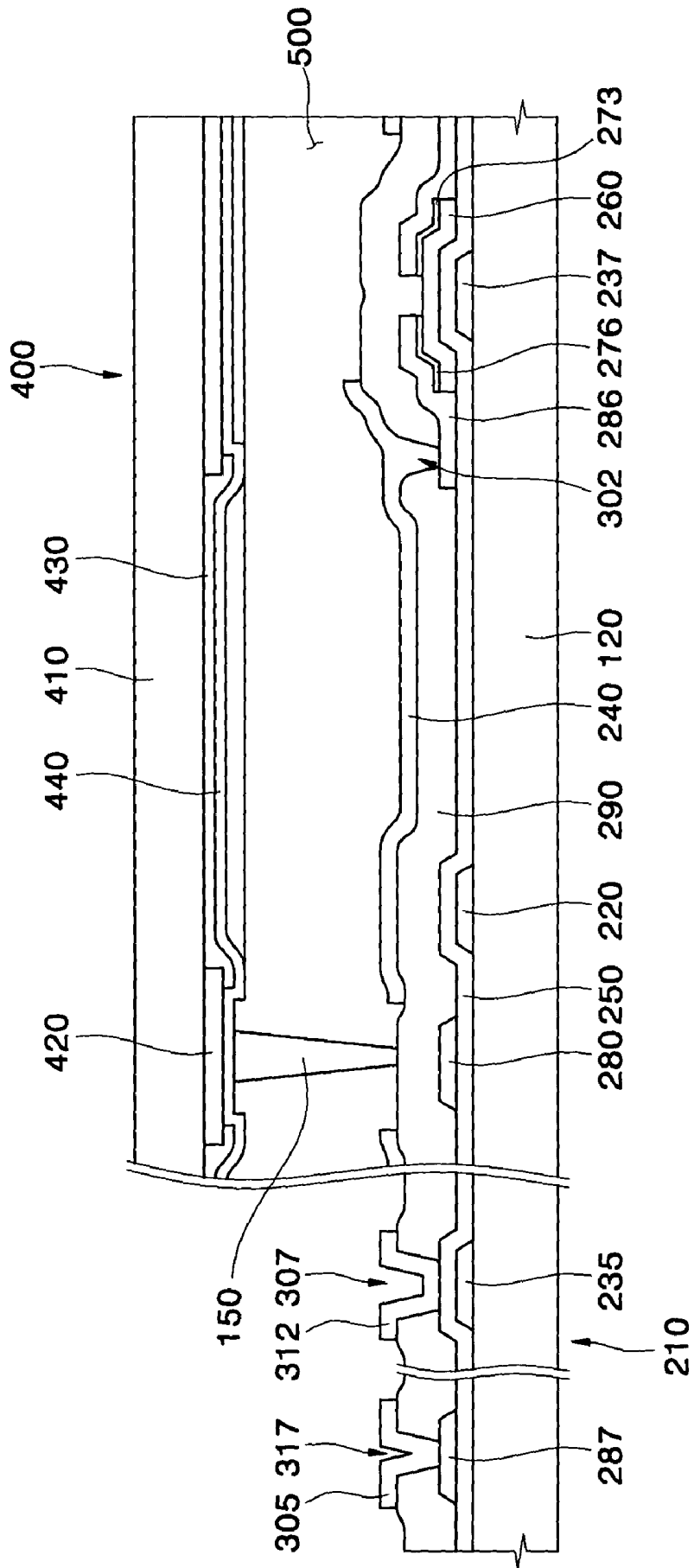

FIG. 10

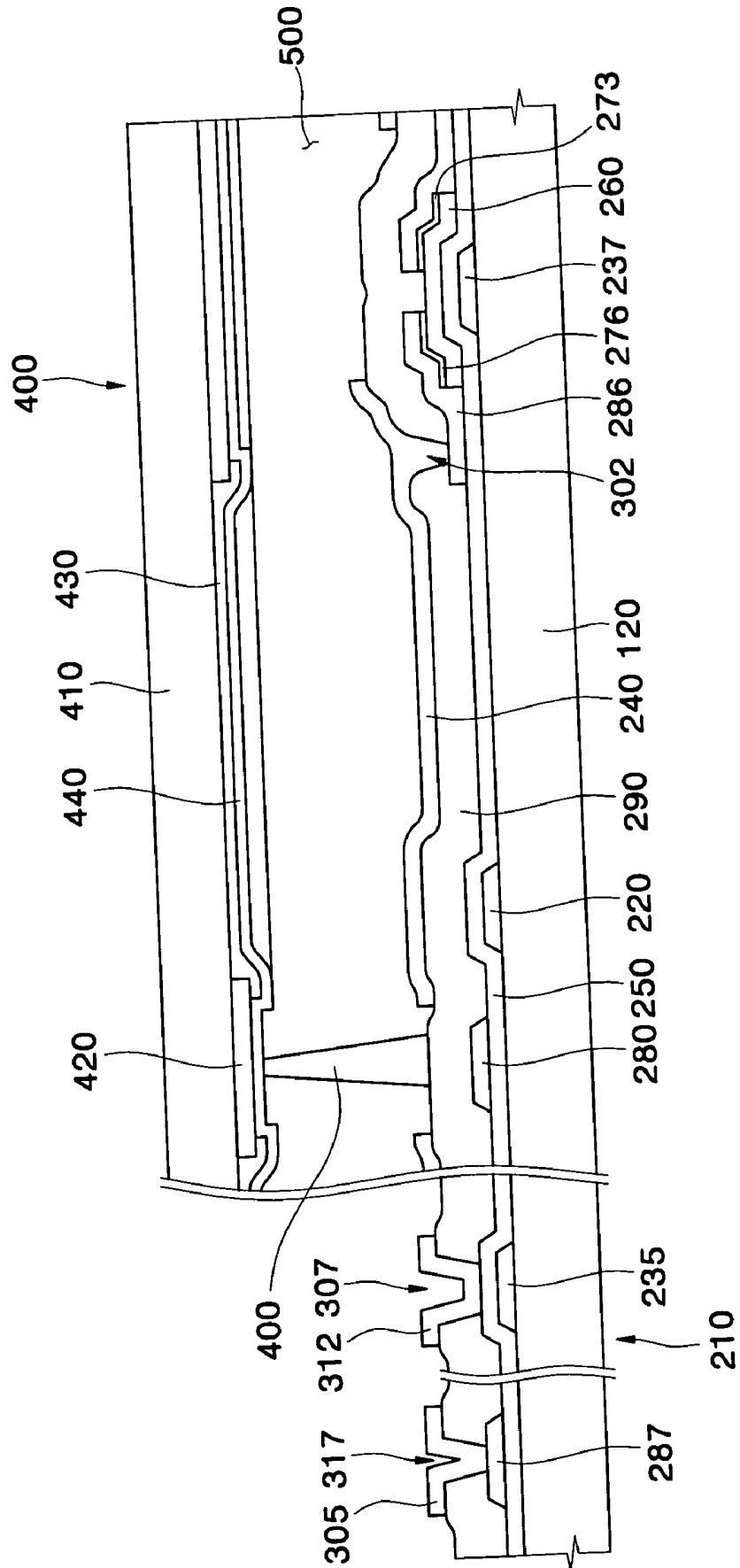

FIG. 11

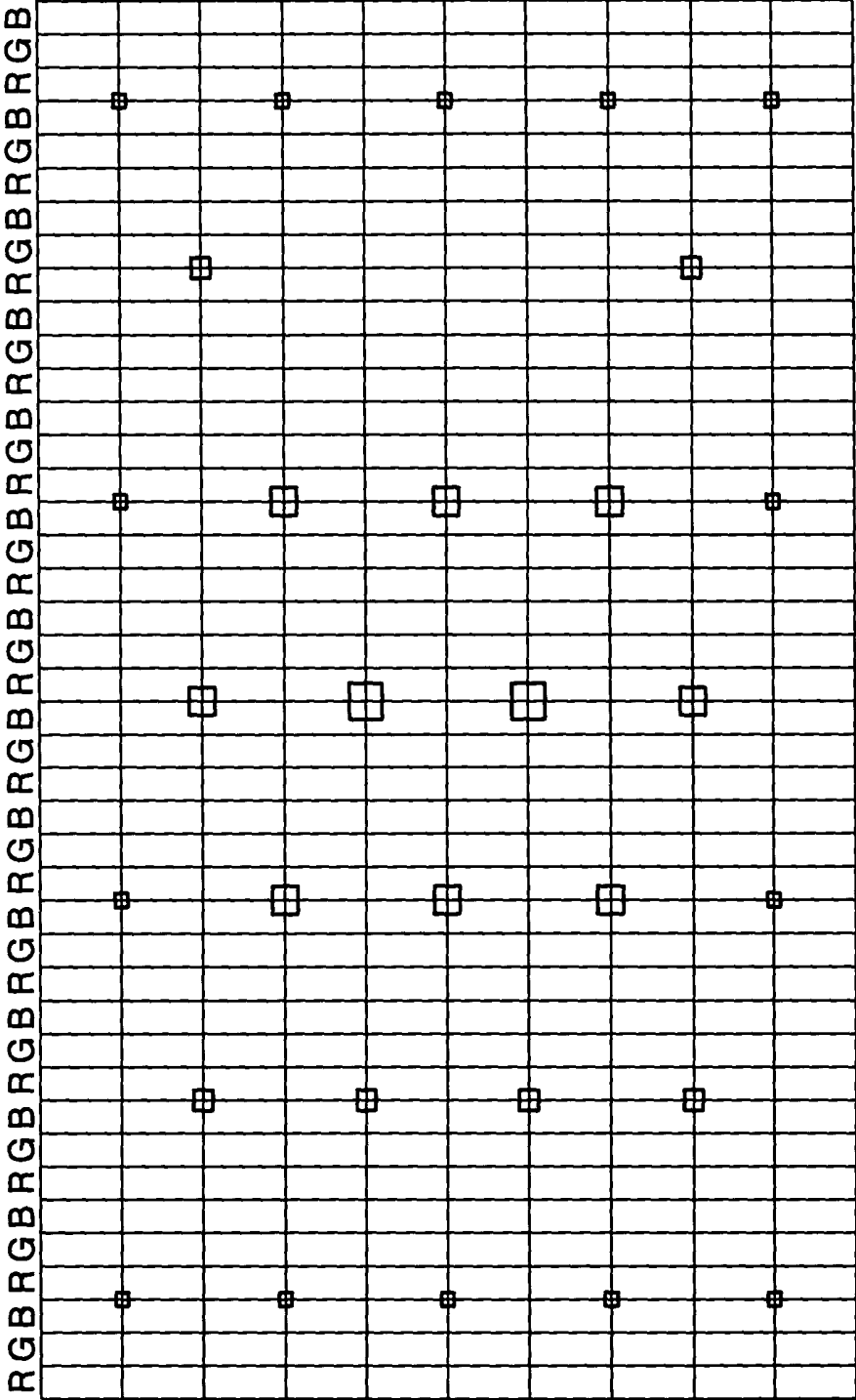

FIG. 12

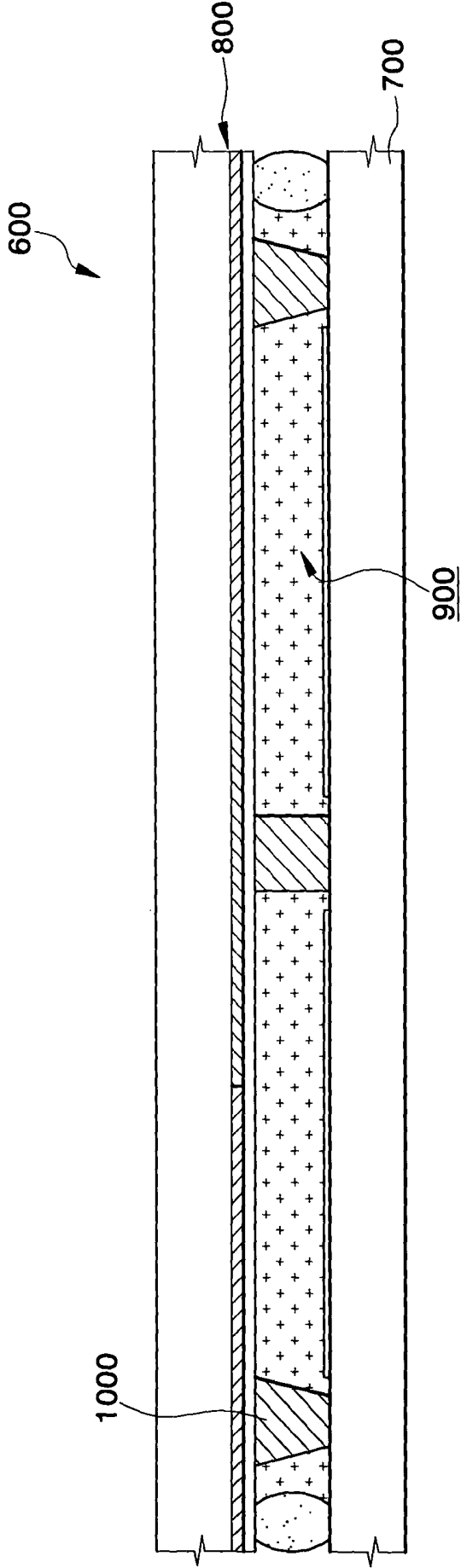

FIG. 14

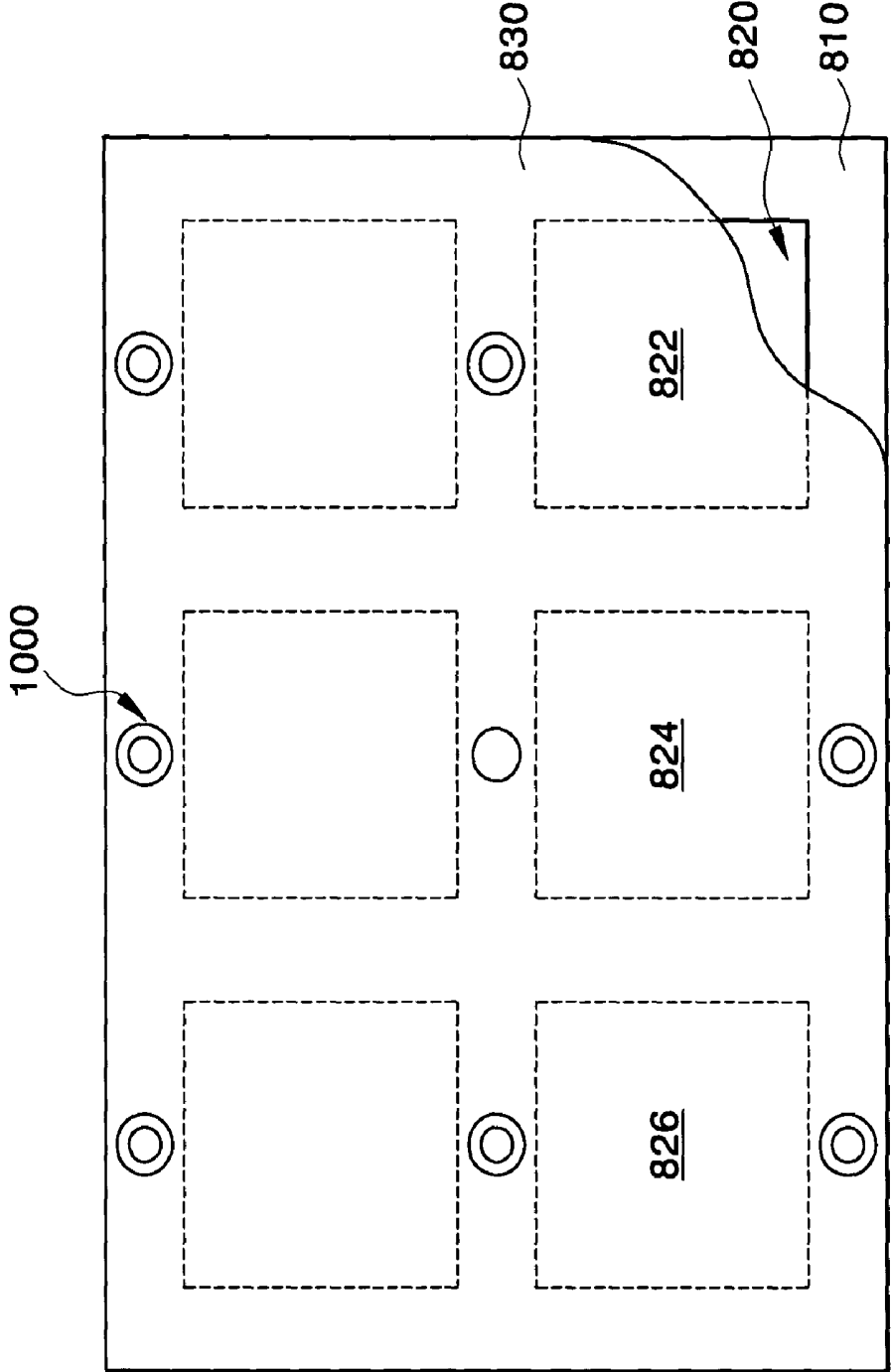

FIG. 15

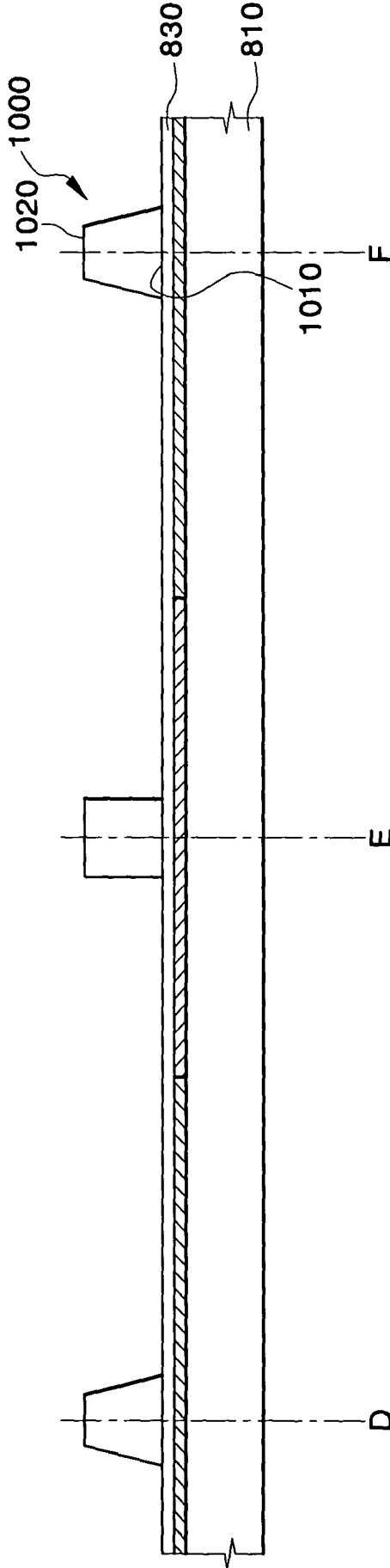

FIG. 16

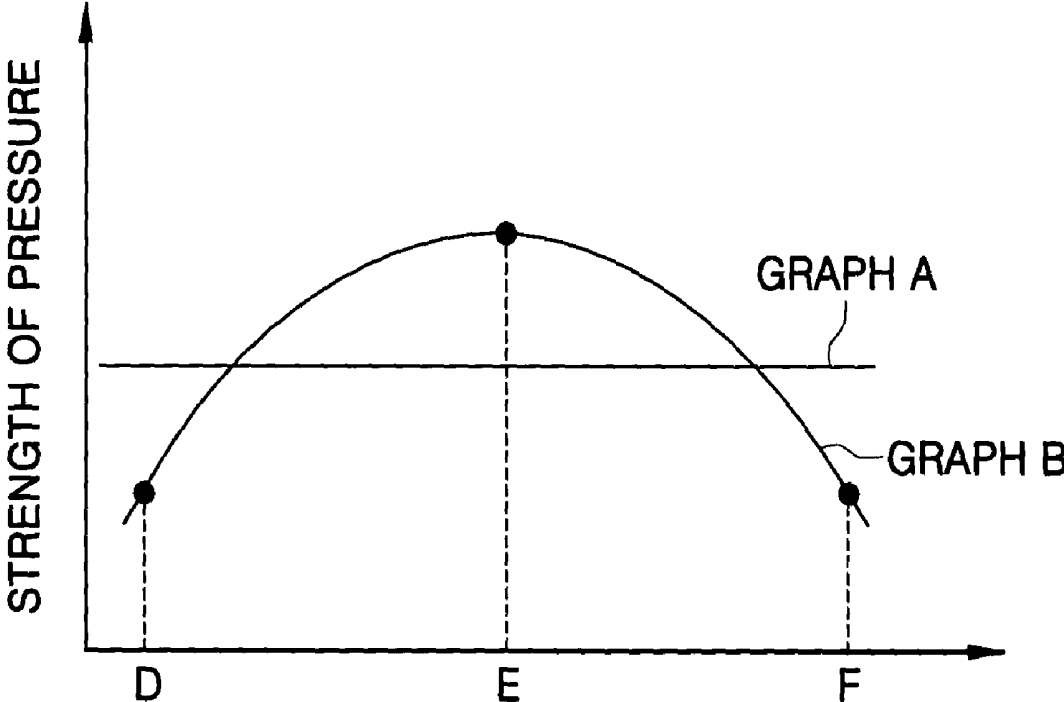

FIG. 17A

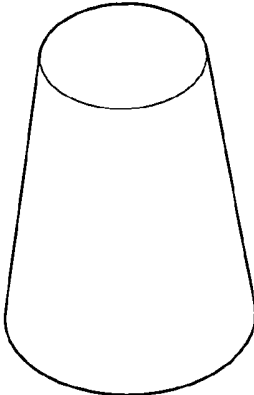

FIG. 17B

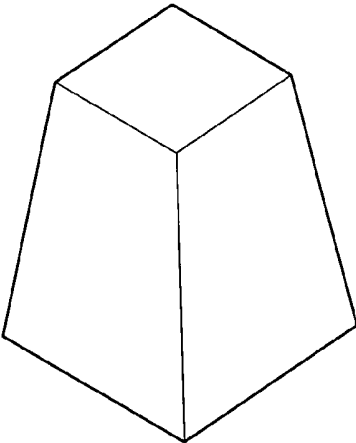

FIG. 17C

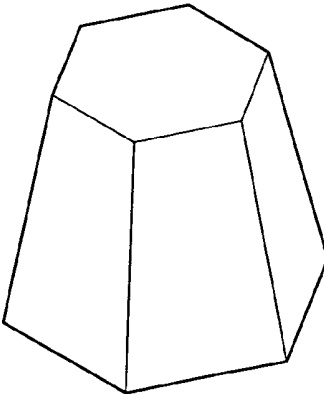

FIG. 18A

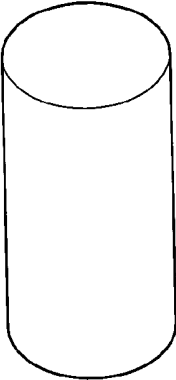

FIG. 18B

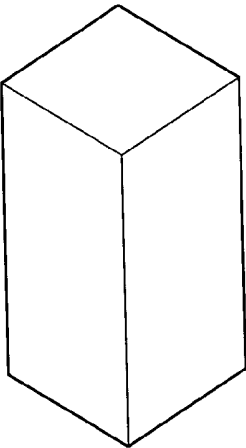

FIG. 18C

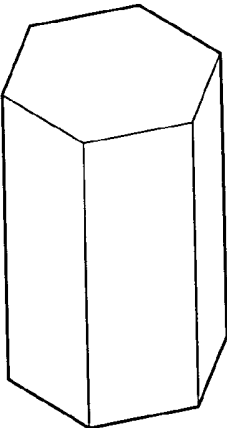

FIG. 19

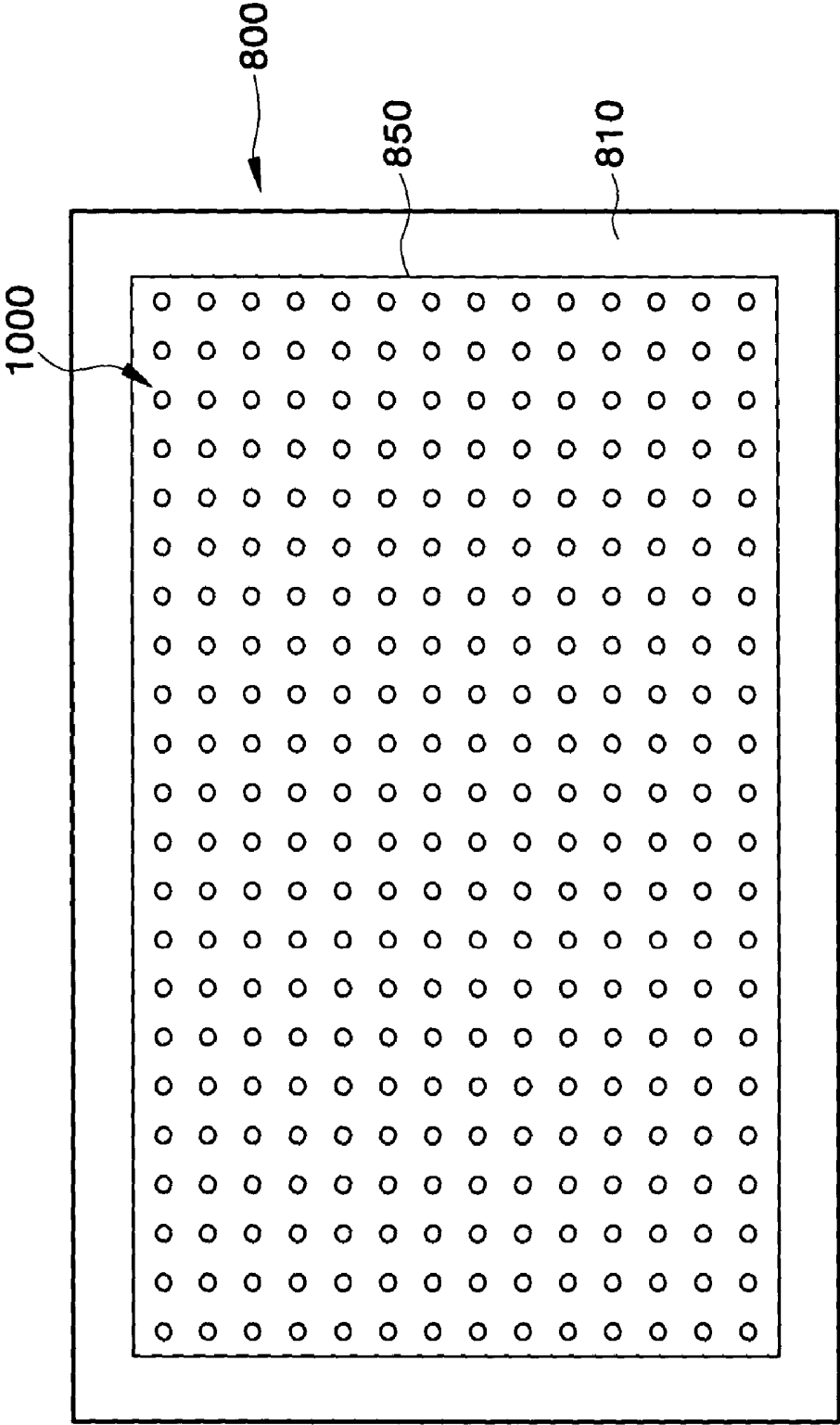

FIG. 20

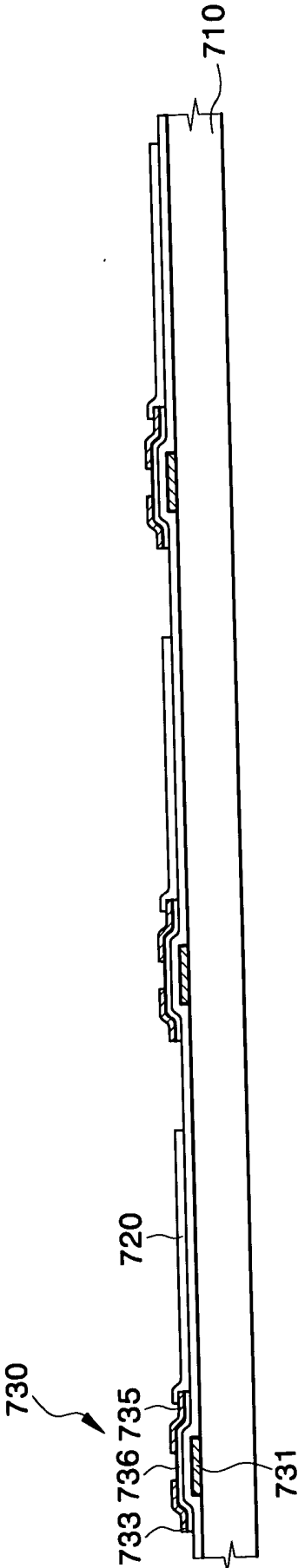

FIG. 21

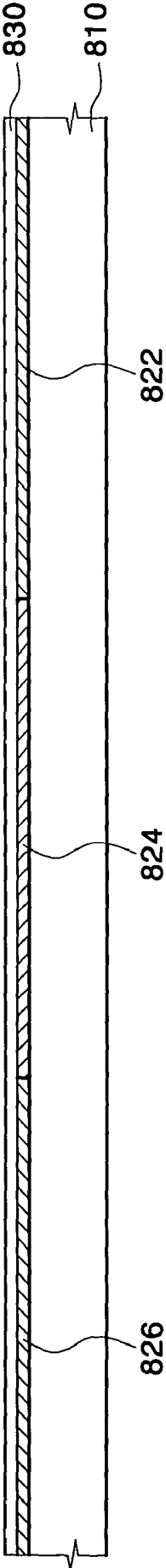

FIG. 22

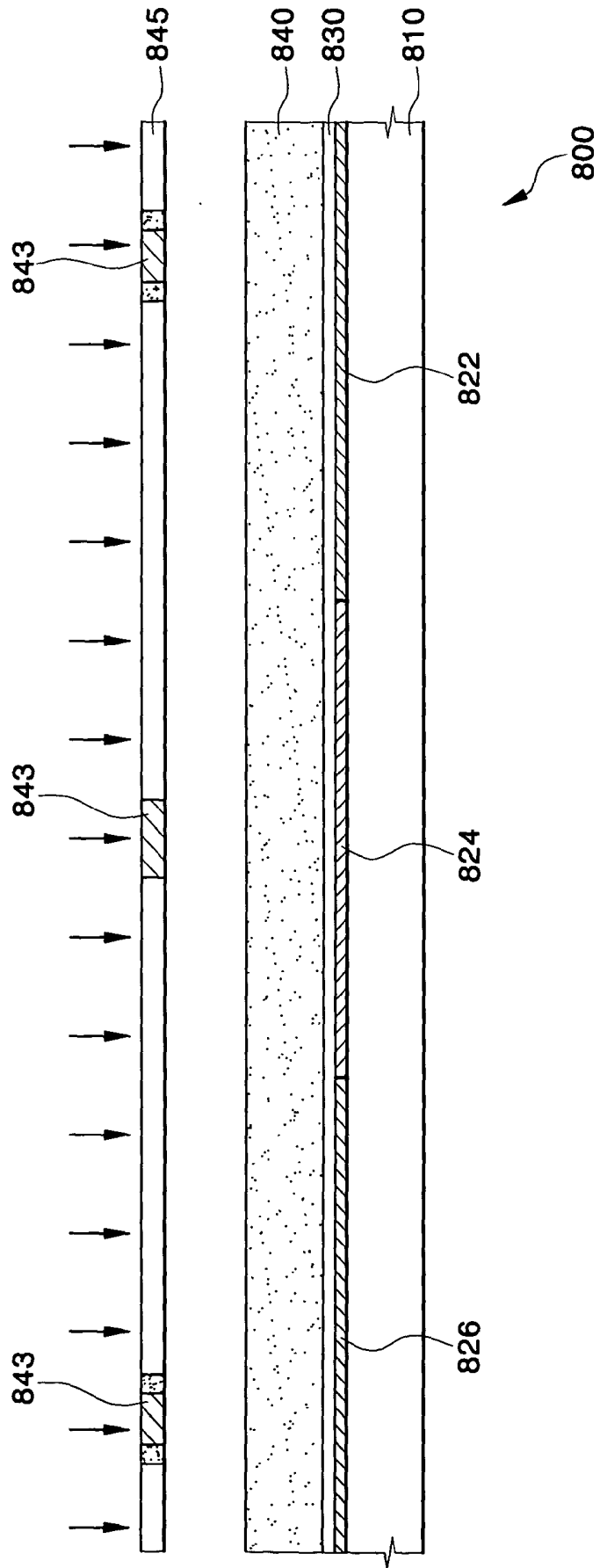

FIG. 23

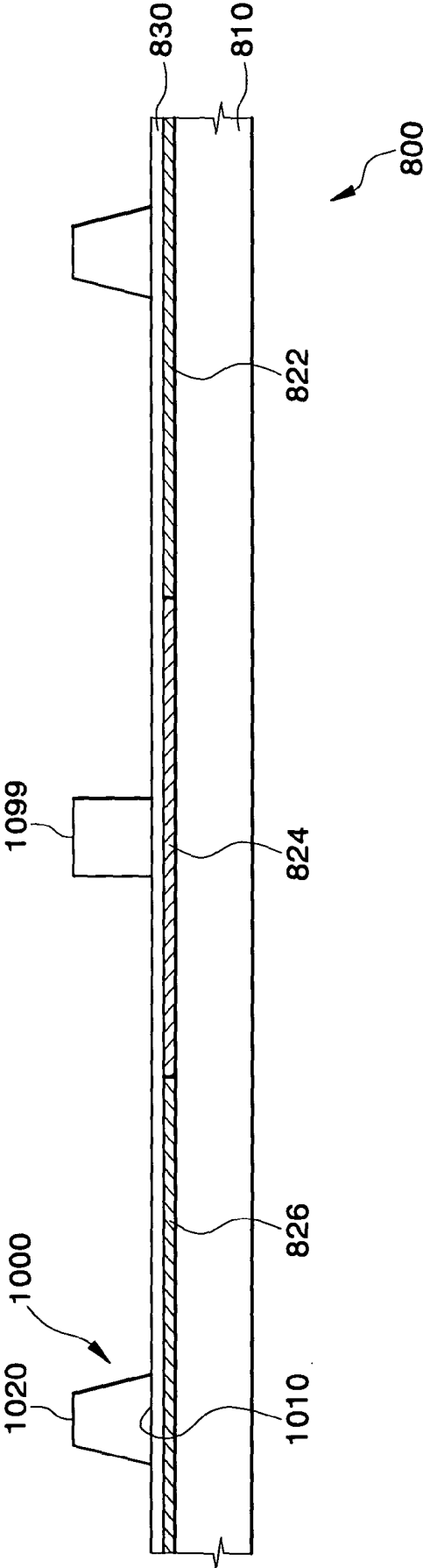

FIG. 24

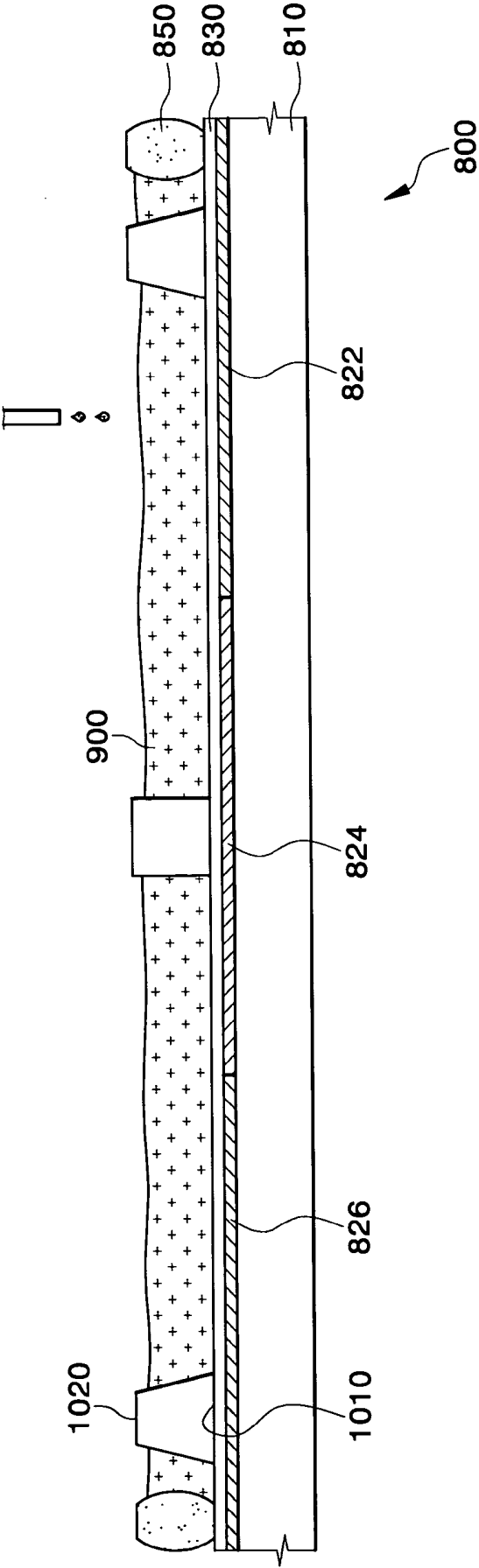

FIG. 25

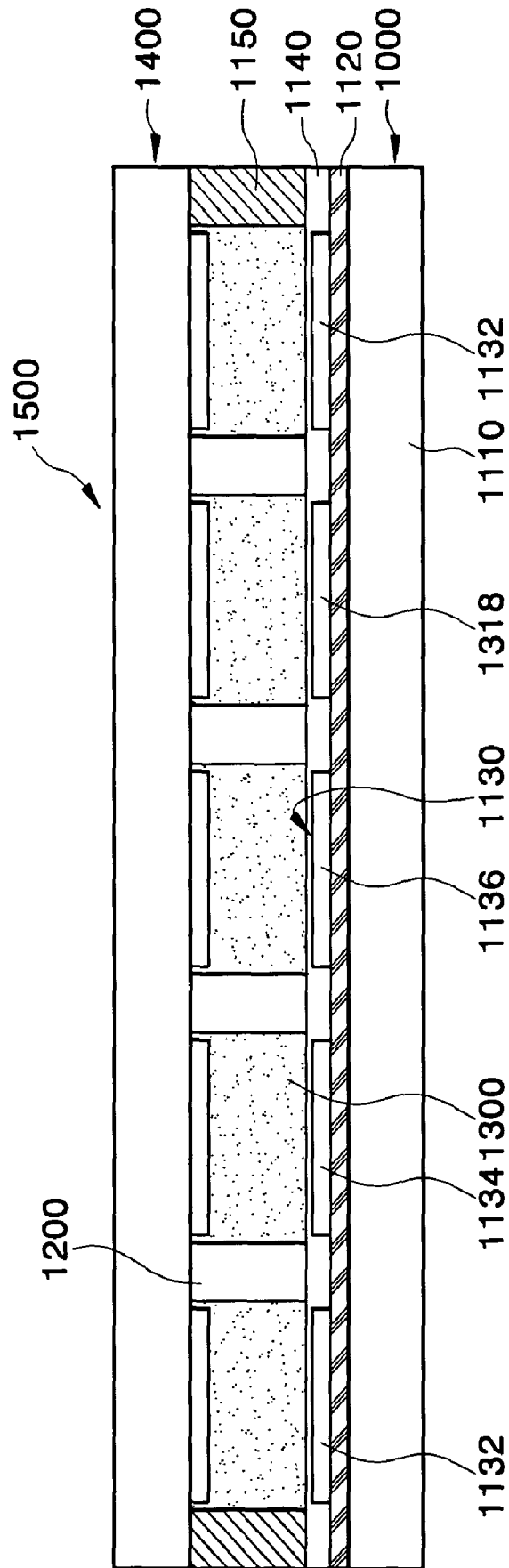

FIG. 26

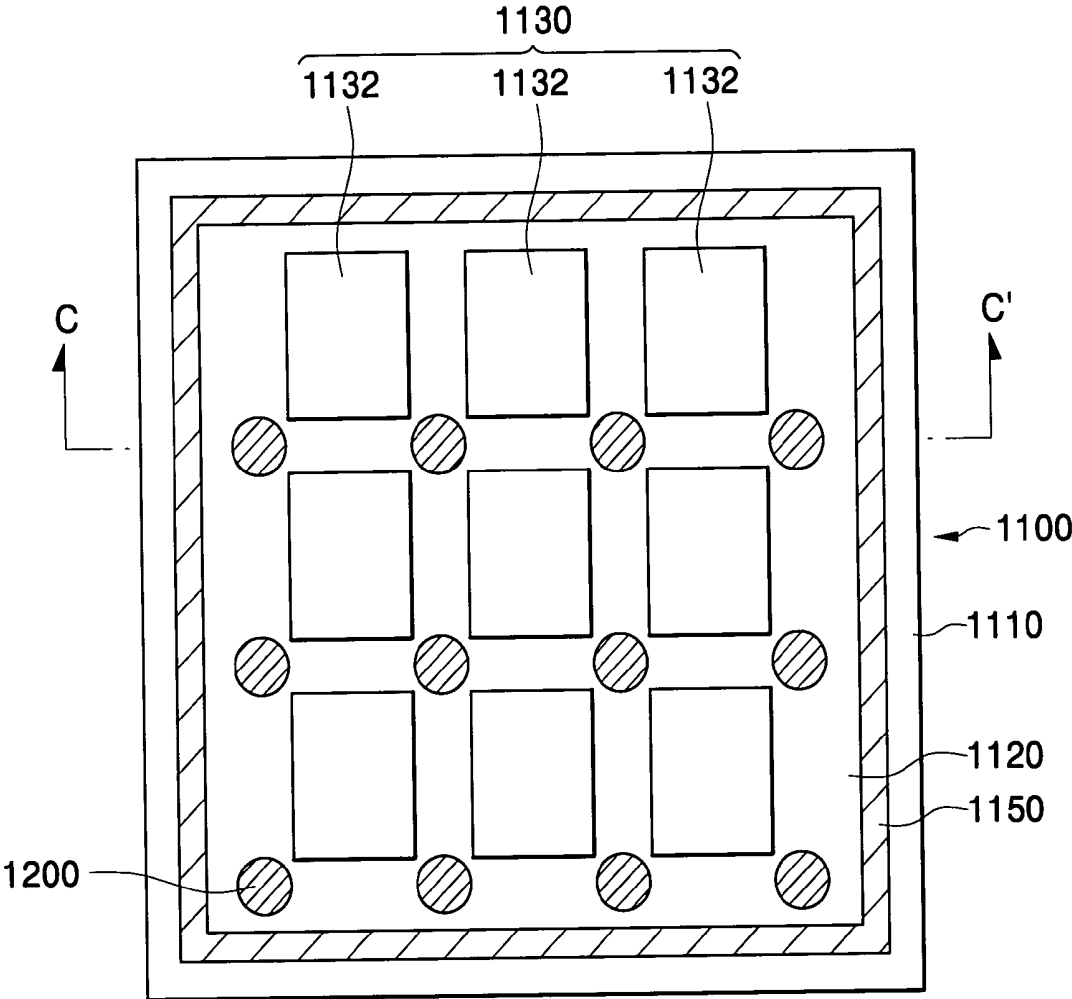

FIG. 27

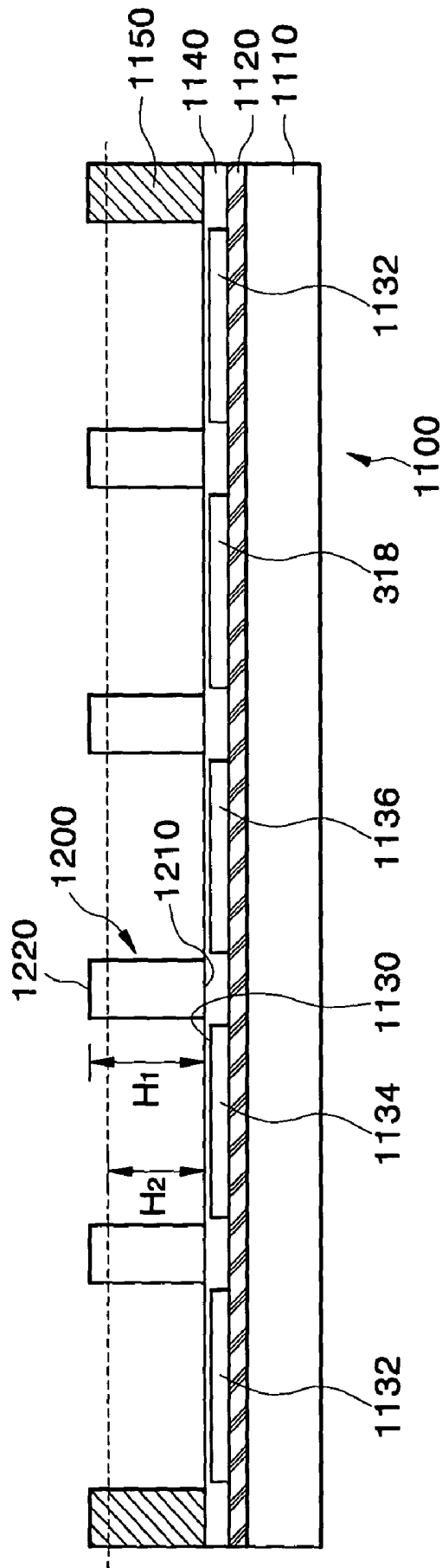

FIG. 28A

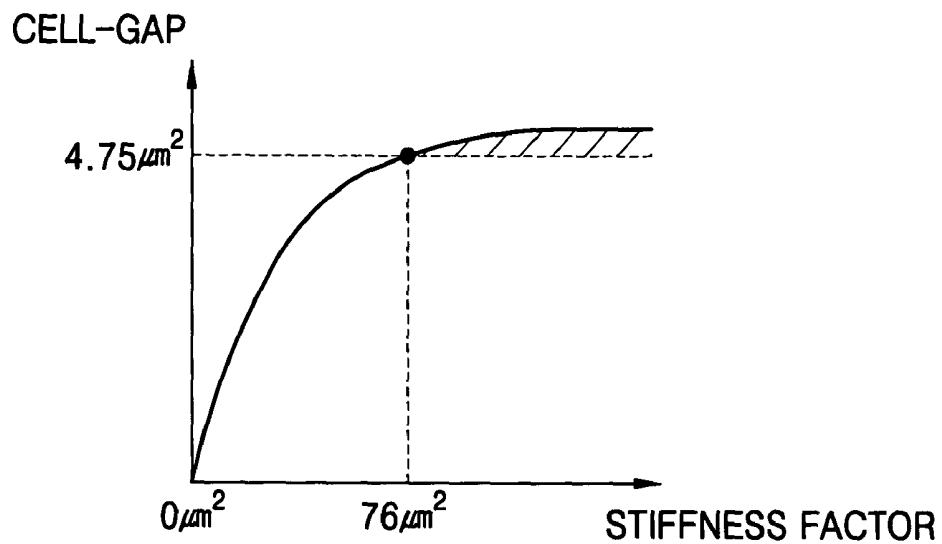

FIG. 28B

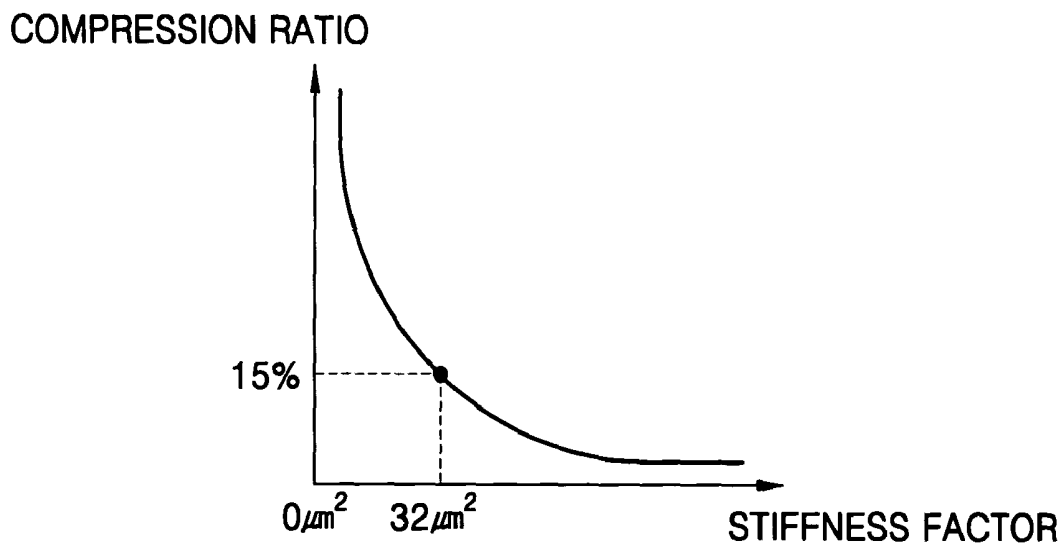

FIG. 29A

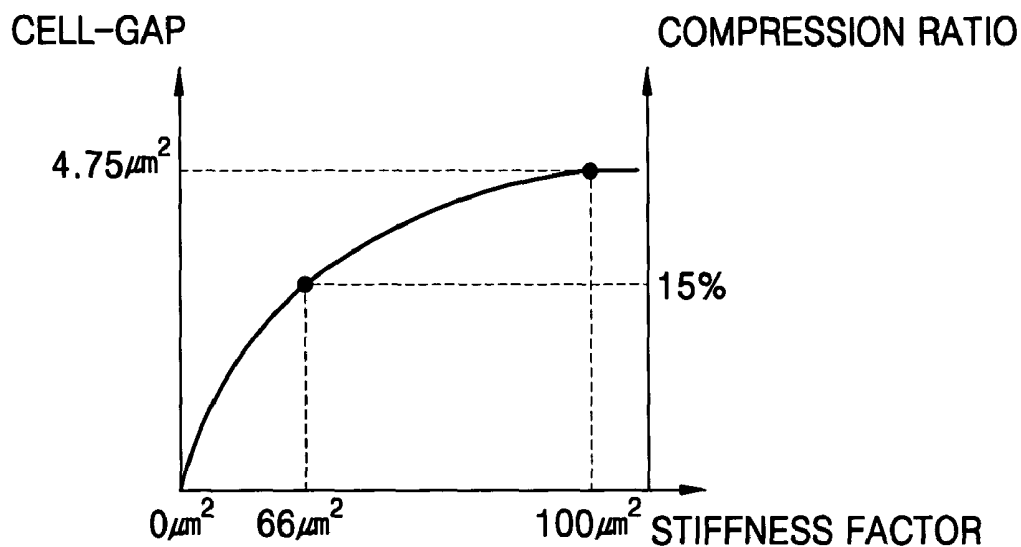

FIG. 29B

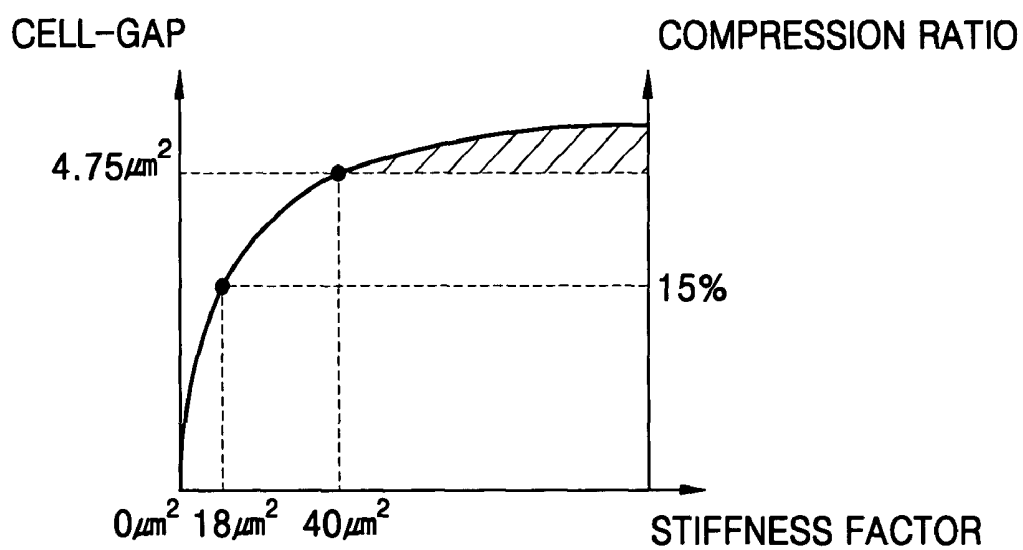

FIG. 30

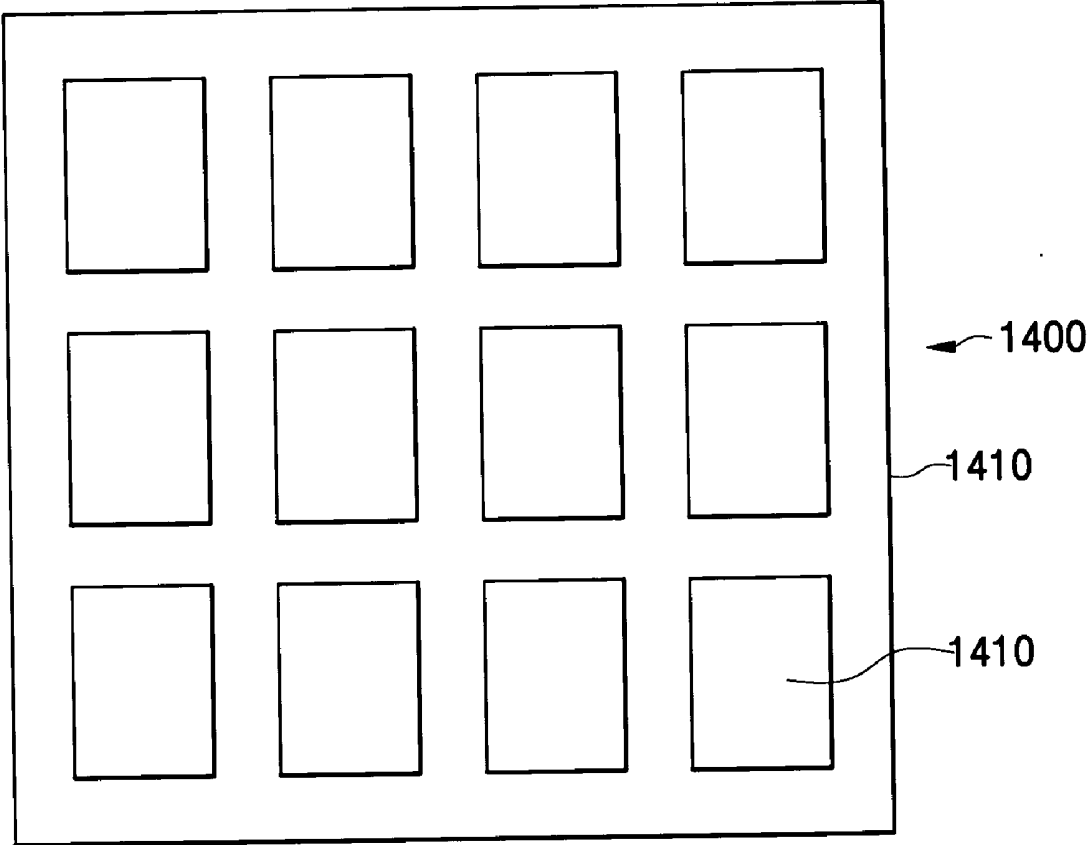

FIG. 31D

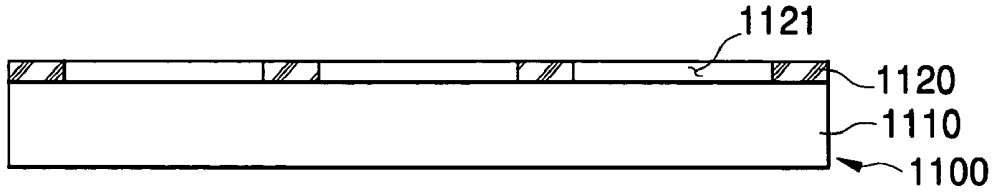

FIG. 31E

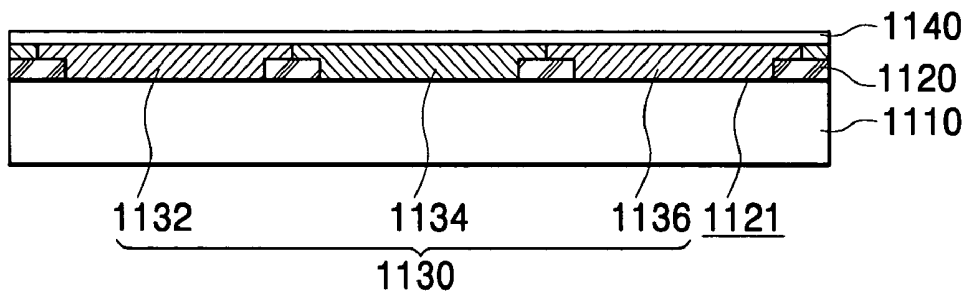

FIG. 31F

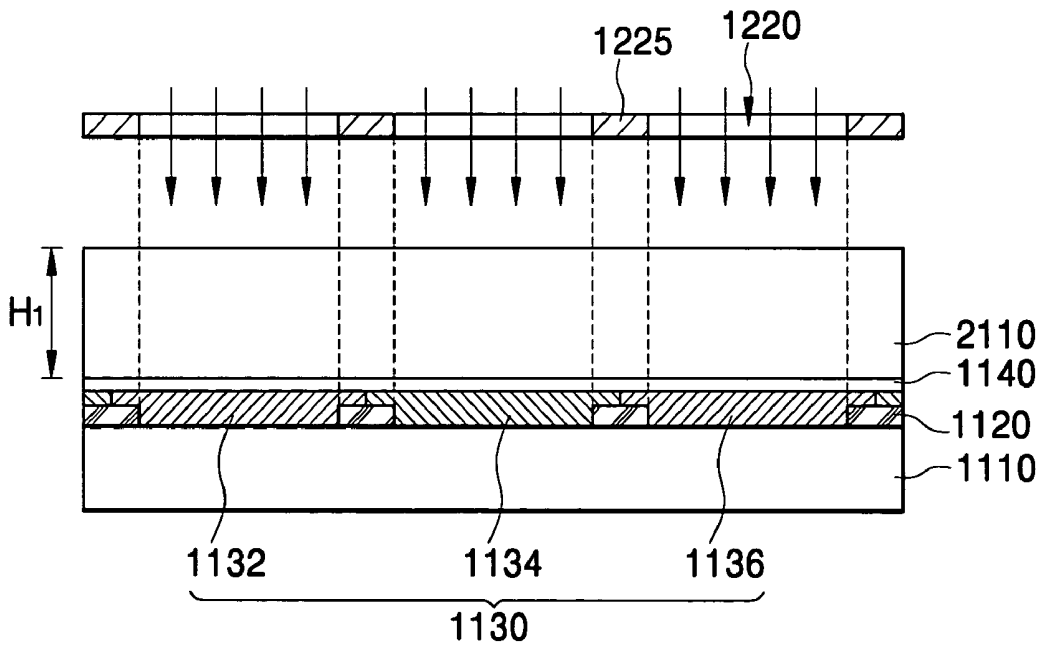

FIG. 31G

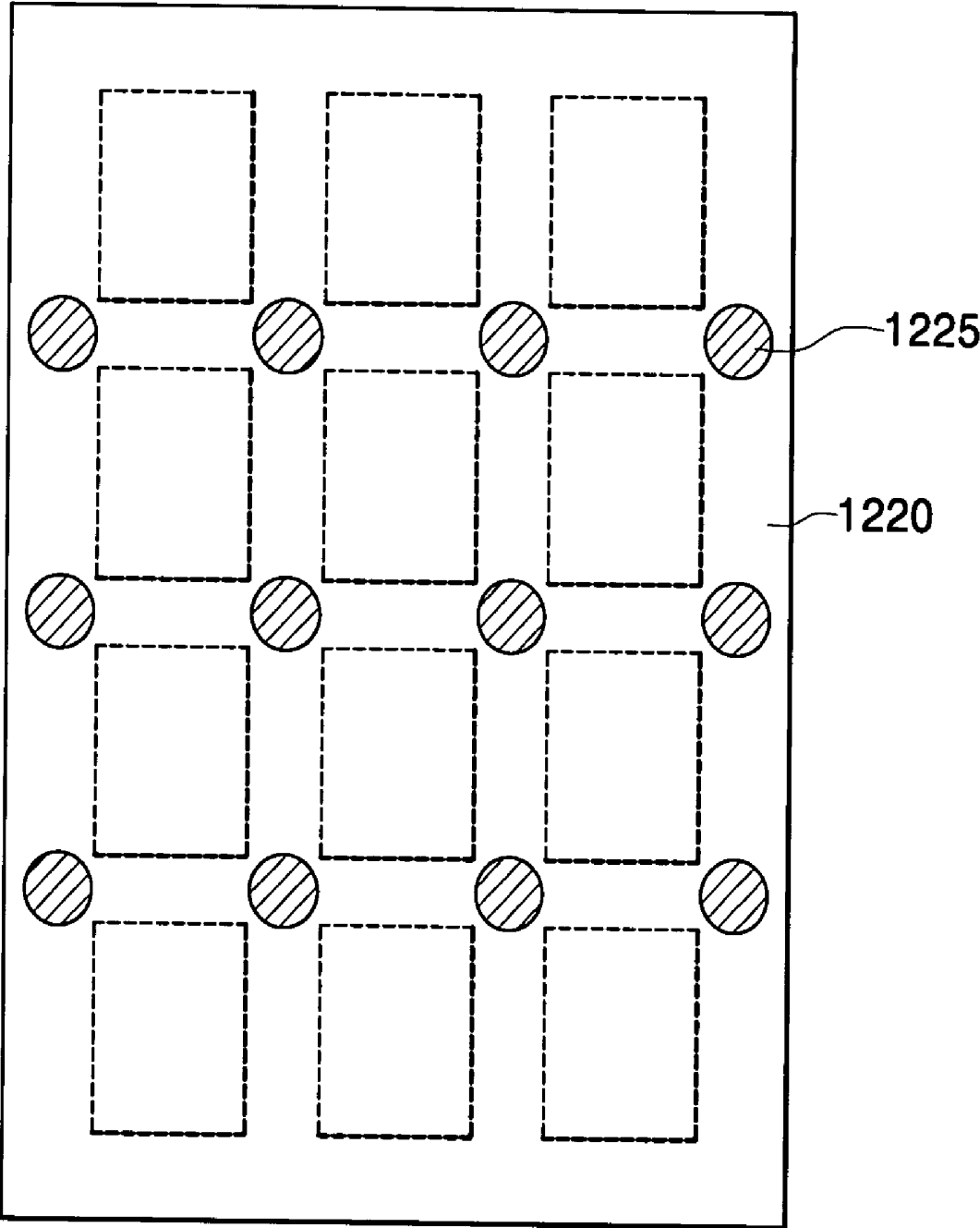

FIG. 31H

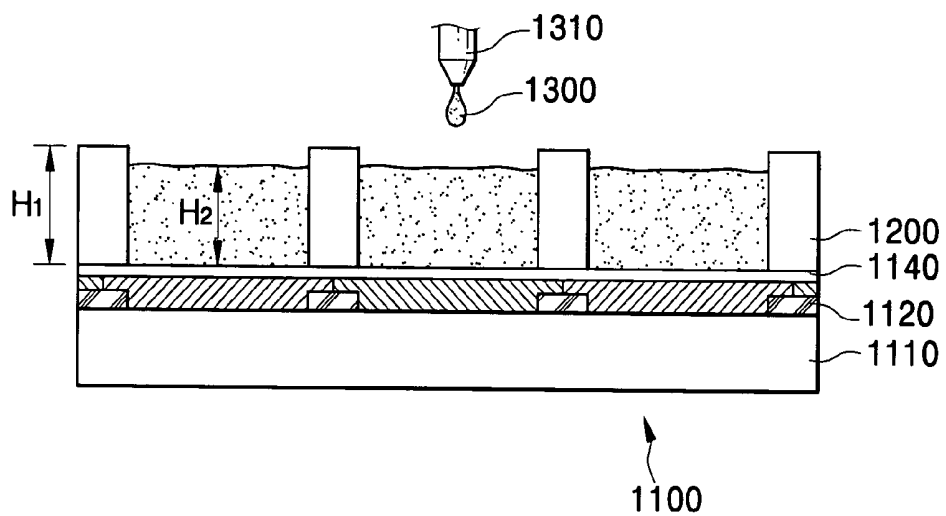

FIG. 31I

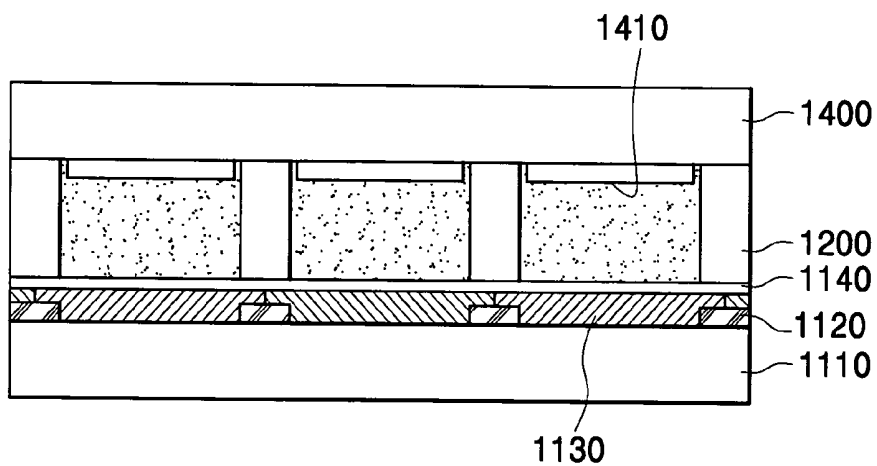
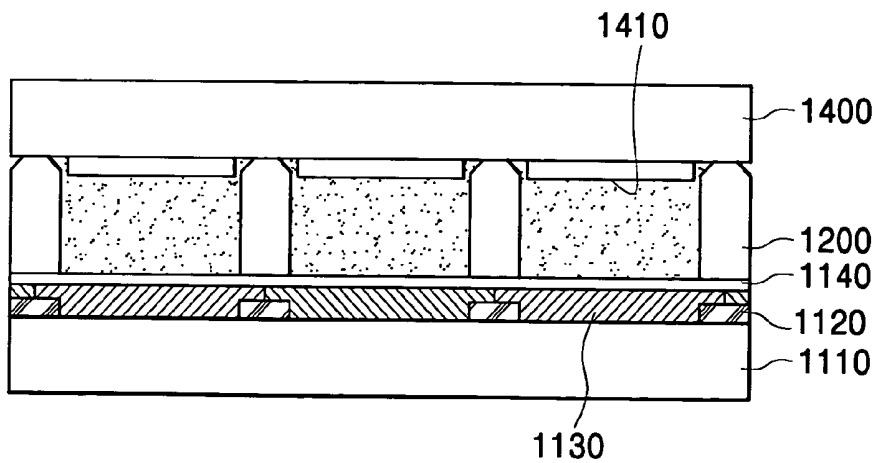

FIG. 31J



**SUBSTRATE, LIQUID CRYSTAL DISPLAY
DEVICE, AND METHOD OF MANUFACTURING
THE SAME**

CROSS-REFERENCE TO RELATED
APPLICATIONS

[0001] This application relies for priority upon Korean Patent Application No. 2002-49576 filed on Aug. 21, 2002, Korean Patent Application No. 2002-60498 filed on Oct. 4, 2002 and Korean Patent Application No. 2002-66617 filed on Oct. 30, 2002, the contents of which are herein incorporated by reference in their entirety.

BACKGROUND OF THE INVENTION

[0002] 1. Field of the Invention

[0003] The present invention relates to a substrate that is used for a liquid crystal display device, a liquid crystal display device having the substrate and a method of manufacturing the liquid crystal display device, and more particularly to a substrate that maintains a uniform cell gap in spite of self-weight, a liquid crystal display device having no unfilled-region, and a manufacturing the liquid crystal display device preventing the overflow of the liquid crystal molecules.

[0004] 2. Description of the Related Art

[0005] Generally, a liquid crystal display device includes a thin film transistor substrate, a color filter substrate and a liquid crystal layer interposed between the thin film transistor and the color filter substrate.

[0006] When a thickness of the liquid crystal layer (or a cell gap between the thin film transistor substrate and the color filter substrate) is non-uniform, a display quality of the liquid crystal display device is deteriorated.

[0007] A spacer is interposed between the thin film transistor substrate and the color filter substrate, so as to maintain the cell gap between the thin film transistor substrate and the color filter substrate.

[0008] The spacer has a spherical shape or a column-shape. The spacer that has a spherical shape is referred to as a ball spacer. The spacer that has a column-shape is referred to as a rigid spacer.

[0009] A diameter of the ball spacer is only a few μm . The ball spacer is scattered on the color filter substrate or on the thin film transistor substrate.

[0010] The ball spacer has demerits as follows.

[0011] Firstly, the ball spacer is deformable and scattered irregularly, so that the cell gap is not uniform. Secondly, a liquid crystal molecule near the ball spacer is abnormally arranged to lower a luminance. Thirdly, reducing the diameter of the ball spacer is very hard, so that making a short cell gap is also very hard. Fourthly, the ball spacer may be disposed on a pixel to deteriorate a display quality.

[0012] A photoresist formed on the thin film transistor substrate or on the color filter substrate is etched to form the rigid substrate. Thus, the rigid substrate may be formed in a region between the pixels, so that the display quality is not deteriorated. Further, the photoresist may have a thin thickness. Thus, the cell gap may be reduced.

[0013] However, when a different compression is applied depending on regions, the cell gap is different according to the regions.

[0014] For example, when the thin film transistor substrate is over the color filter substrate with reference to a gravitational force, the thin film transistor substrate sags due to an atmospheric pressure and a self-weight of the thin film transistor substrate.

[0015] FIG. 1 is a graph showing a relation between a cell gap and a position of a thin film transistor substrate, when a general rigid spacer is used.

[0016] A point 'A' represents a position near a first edge of a thin film transistor substrate. A point 'B' represents a center position of the thin film transistor substrate. A point 'C' represents a position near a second edge that is opposite to the first edge of the thin film transistor substrate.

[0017] Referring to FIG. 1, a cell gap at the center position 'B' of the thin film transistor is minimum, and the cell gap increases in a direction from the center position 'B' to the edge position 'C'. That is, because compression is maximum at the center due to a self-weight of the thin film transistor substrate.

[0018] Thus, a rigid spacer formed at the center 'B' is compressed more than a rigid spacer formed at the edges 'A' and 'C', so that the rigid spacer formed at the center 'B' or the center portion of the color filter substrate and the thin film transistor substrate may be damaged.

[0019] Recently, as a liquid crystal display apparatus becomes larger, a method of filling the liquid crystal is changed from a vacuum injection method into a drop and filling method.

[0020] In the drop and filling method, liquid crystal material is dropped on the color filter substrate having a spacer formed thereon. Then, the color filter substrate and the thin film transistor substrate are assembled with each other.

[0021] The drop and filling method is simple in comparison with the vacuum injection method. However, a liquid crystal display apparatus manufactured by the drop and filling method may include an unfilled region where the liquid crystal is not completely filled, or the liquid crystal material may overflow, when the liquid crystal material is too much.

[0022] In detail, when the liquid crystal material is provided too much, the liquid crystal material overflows, so that the thin film transistor substrate and the color filter substrate are not completely assembled. When the liquid crystal material is provided insufficiently, the liquid crystal display apparatus includes the unfilled region.

[0023] The unfilled region deteriorates a display quality of the liquid crystal display apparatus.

[0024] Due to these problems, a vacuum injection method is used in spite of complexity of procedure and much consumption of liquid crystal material.

[0025] However, as the liquid crystal display apparatus becomes larger, the vacuum injection method meets a limit. Thus, the drop and filling method has been developed.

[0026] In the drop and filling method, the amount of the spacer and the liquid crystal material is important.

SUMMARY OF THE INVENTION

[0027] Accordingly, the present invention is provided to substantially obviate one or more problems due to limitations and disadvantages of the related art.

[0028] It is a feature of the present invention to provide a substrate for liquid crystal display apparatus.

[0029] In one aspect of the present invention, a liquid crystal display apparatus having the substrate is provided.

[0030] In another aspect of the present invention, a method of manufacturing a liquid crystal display apparatus is provided.

[0031] According to the substrate of this invention, the substrate includes a transparent substrate and a plurality of spacers. The transparent substrate includes a display region for displaying an image. The spacers are formed in the display region. The spacers have a gradually increasing compression ratio in a direction from a center of the display region to an edge of the display region.

[0032] The liquid crystal display apparatus includes a first substrate, a second substrate, a fence, a liquid crystal layer and a plurality of spacers. The first substrate includes a display region for displaying an image. The second substrate faces the first substrate. The fence is disposed between the first substrate and the second substrate. The fence surrounds the display region to form a space defined by the first and the second substrates and the fence. The liquid crystal layer is disposed in the space. The spacers are disposed in the space. The spacers maintain the distance between the first and second substrates. The spacers have a gradually increasing compression ratio in a direction from a center of the display region to an edge of the display region.

[0033] According to the method of manufacturing the liquid crystal display apparatus, a first substrate including a display region for displaying an image is formed. A second substrate is formed. A plurality of spacers is formed on the display region of the first substrate. The spacers have a gradually increasing compression ratio in a direction from a center of the display region to an edge of the display region. A fence is formed on the first substrate, such that the fence surrounds the display region to form a space defined by the first substrate and the fence. Liquid crystal is dropped in the space to fill the space. Then, the first and second substrates are assembled with each other.

[0034] According to another method of manufacturing the liquid crystal display apparatus, a first substrate including a display region for displaying an image is formed. A second substrate is formed. A density and a cross-sectional area of spacers are calculated from a comparative liquid crystal display panel. Then, the spacers according to the calculated density and the cross-sectional area are formed on the first substrate. A fence is formed on the first substrate, such that the fence surrounds the display region to form a space defined by the first substrate and the fence. Liquid crystal is dropped in the space to fill the space. Then, the first and second substrates are assembled with each other.

[0035] The liquid crystal display apparatus maintains a uniform cell gap, even though a compressive stress of a center portion of the liquid crystal display apparatus is different from a compressive stress of an edge portion of the liquid crystal display apparatus. Therefore, display quality is enhanced.

[0036] According to the method of manufacturing a liquid crystal display apparatus, the density and the cross-sectional area are adjusted, so that an unfilled region where the liquid crystal is not filled is not formed. Thus, the display quality is also enhanced. Further, the first and second substrates are not damaged while assembling the first and second substrates.

BRIEF DESCRIPTION OF THE DRAWINGS

[0037] The above and other features and advantage points of the present invention will become more apparent by describing in detailed exemplary embodiments thereof with reference to the accompanying drawings, in which:

[0038] FIG. 1 is a graph showing a relation between a cell gap and a position of a thin film transistor substrate, when a general rigid spacer is used;

[0039] FIG. 2 is a schematic plan view showing a mother substrate of liquid crystal display panel according to a first exemplary embodiment;

[0040] FIG. 3 is a cross-sectional view taken along a line A-A' of FIG. 2;

[0041] FIG. 4 is a cross-sectional view showing a liquid crystal display apparatus according to a second exemplary embodiment;

[0042] FIG. 5 is a cross-sectional view showing a liquid crystal display apparatus according to a third exemplary embodiment;

[0043] FIG. 6 is a graph showing a relation between a compressive stress and an amount of compression for different energy of exposure process is applied;

[0044] FIG. 7 is a graph showing a relation between energy of exposure process and an amount of compression (or Young's modulus);

[0045] FIG. 8 is a layout showing a portion of a thin film transistor substrate of a liquid crystal display apparatus according to a fourth exemplary embodiment of the present invention;

[0046] FIG. 9 is a cross-sectional view taken along a line B-B' of FIG. 8;

[0047] FIG. 10 is a cross-sectional view showing a liquid crystal display apparatus according to a fourth exemplary embodiment of the present invention;

[0048] FIG. 11 is a schematic view showing an arrangement of spacers according to a fifth exemplary embodiment of the present invention;

[0049] FIG. 12 is a cross-sectional view showing a liquid crystal display apparatus according to a sixth exemplary embodiment of the present invention;

[0050] FIG. 13 is a schematic view showing a thin film transistor substrate of FIG. 12;

[0051] FIG. 14 is a schematic view showing a color filter substrate of FIG. 12;

[0052] FIG. 15 is a cross-sectional view showing spacers formed on a color filter substrate of FIG. 12;

[0053] FIG. 16 is a graph showing a relation between amount of compression and a position;

[0054] FIGS. 17A to 17C are perspective views showing spacers formed in an edge portion of a color filter substrate;

[0055] FIGS. 18A to 18C are perspective views showing spacers formed in a center portion of a color filter substrate;

[0056] FIG. 19 is a schematic plan view showing spacers and fence formed on a color filter substrate;

[0057] FIG. 20 is a cross-sectional view showing a process of manufacturing a thin film transistor substrate of a liquid crystal display apparatus according to a sixth exemplary embodiment of the present invention;

[0058] FIG. 21 is a cross-sectional view showing a process of manufacturing a color filter substrate of a liquid crystal display apparatus according to a sixth exemplary embodiment of the present invention;

[0059] FIG. 22 is a cross-sectional view showing a process of manufacturing spacers according to a sixth exemplary embodiment of the present invention;

[0060] FIG. 23 is a cross-sectional view showing a spacers formed on a color filter substrate according to a sixth exemplary embodiment of the present invention;

[0061] FIG. 24 is a cross-sectional view showing a liquid crystal filled in a space formed by a fence and a color filter substrate cross-sectional view showing a process of manufacturing spacers according to a sixth exemplary embodiment of the present invention;

[0062] FIG. 25 is a cross-sectional view showing a liquid crystal display apparatus according to a seventh embodiment of the present invention;

[0063] FIG. 26 is a schematic plan view showing a color filter substrate of a liquid crystal display apparatus of FIG. 25;

[0064] FIG. 27 is a cross-sectional view taken along a line C-C' of FIG. 26;

[0065] FIG. 28A is a graph showing a relation between a cell gap and a stiffness factor, when a Young's modulus is about 487 N/mm²;

[0066] FIG. 28B is a graph showing a relation between a compression ratio and a stiffness factor, when a Young's modulus is about 487 N/mm²;

[0067] FIG. 29A is a graph showing a relation between a cell gap (or a compression ratio) and a stiffness factor, when a Young's modulus is about 243.5 N/mm²;

[0068] FIG. 29B is a graph showing a relation between a cell gap (or a compression ratio) and a stiffness factor, when a Young's modulus is about 974 N/mm²;

[0069] FIG. 30 is a schematic plan view showing a thin film transistor substrate according to a seventh exemplary embodiment of the present invention;

[0070] FIG. 31A is a schematic cross-sectional view showing a chromium thin film formed on a transparent substrate;

[0071] FIG. 31B is a schematic cross-sectional view showing a process of manufacturing a photoresist pattern;

[0072] FIG. 31C is a plan view showing a pattern mask of FIG. 32B;

[0073] FIG. 31D is a schematic cross-sectional view showing a black matrix formed on a transparent substrate;

[0074] FIG. 31E is a schematic cross-sectional view showing a color filters formed on a transparent substrate, a first electrode formed on the color filters;

[0075] FIG. 31F is a schematic cross-sectional view showing a process of forming spacers on a first electrode;

[0076] FIG. 31G is a plan view of a pattern mask of FIG. 3 IF;

[0077] FIG. 31H is a schematic cross-sectional view showing a process of dropping liquid crystal;

[0078] FIG. 31I is a cross-sectional view showing a thin film transistor and a color filter substrates assembled with each other to form a liquid crystal display panel; and

[0079] FIG. 31J is a cross-sectional view showing a liquid crystal display panel having spacers of which on end is tapered.

DESCRIPTION OF THE PREFERRED EMBODIMENTS

[0080] Hereinafter the preferred embodiments of the present invention will be described in detail with reference to the accompanying drawings.

Embodiment 1

[0081] FIG. 2 is a schematic plan view showing a mother substrate of liquid crystal display panel according to a first exemplary embodiment, and FIG. 3 is a cross-sectional view taken along a line A-A' of FIG. 2.

[0082] Referring to FIGS. 2 and 3, a mother substrate 110 of a liquid crystal display panel includes a plurality of liquid crystal display panels 101, 102, 103 and 104.

[0083] The mother substrate 110 includes two substrates 120 and 130, and a liquid crystal layer interposed between the two substrates 120 and 130. Each of the liquid crystal display panels 101, 102, 103 and 104 includes a display region.

[0084] A plurality of spacers 150 is formed between the two substrates 110 and 120. The spacers 150 maintain a cell gap that is a distance between the two substrates 110 and 120.

[0085] The liquid crystal layer 140 is confined within a space defined by the two substrates 110 and 120, and a fence 160.

[0086] As shown in FIG. 3, the spaces 150 have different tapered angles θ_1 , θ_2 and θ_3 from each other.

[0087] The tapered angle θ_3 of a spacer 150 disposed at a center portion is the least. The tapered angle of the spaces 150 increases in a direction from the center portion to an edge portion of each of the liquid crystal display panels 101, 102, 103 and 104.

[0088] A compression ratio of the spacers 150 is inversely proportional to a value that is obtained by multiplying an upper diameter by a lower diameter of the spacer 150. Thus, the value obtained by multiplying the upper diameter by the lower diameter of the spacer 150 that is disposed at the center is larger than that of the spacer 150 that is disposed

at the edge of the liquid crystal display panel, so that the compression ratio of the spacers **150** becomes larger in a direction from the center to the edge.

[0089] Thus, the cell gap of the center is substantially equal to the cell gap of the edge, even though the compression at the center is large due to the self-weight.

[0090] The fence **160** may be used as a spacer **150** that maintains the cell gap between the two substrates **120** and **130**.

Embodiment 2

[0091] FIG. 4 is a cross-sectional view showing a liquid crystal display apparatus according to a second exemplary embodiment.

[0092] The liquid crystal display apparatus of the present embodiment is similar to the liquid crystal display apparatus of Embodiment 1 except that a shape of the spacers is different from that of Embodiment 1. Thus, in FIG. 4, the same reference numbers will be used to refer to the same or like parts as those shown in FIG. 3.

[0093] Referring to FIGS. 2 and 4, spacers **170** support the two substrates **120** and **130**. A diameter of the spacers **170** becomes smaller in a direction from the center to the edge, so that a compression ratio becomes larger in the direction.

[0094] In other word, an area of a contact face between the spacers **170** and the two substrates **120** and **130** becomes smaller in a direction from the center to the edge.

[0095] Thus, the cell gap of the center is substantially equal to the cell gap of the edge, even though the compression at the center is large due to the self-weight.

[0096] In FIG. 4, tapered angles of the spacers **170** are the same. However, the tapered angles may be different from each other.

[0097] Referring again to FIGS. 3 and 4, a compressed amount δ of the spacers **150** or **170** is inversely proportional to a value that is obtained by multiplying an upper diameter D_1 by a lower diameter D_2 of the spacer **150** or **170**, as shown in the following Expression 1.

$$\begin{aligned} \delta &= \int_0^{L_0} \varepsilon_L dL = \frac{4P}{\pi E} \int_0^{L_0} \frac{1}{(D_1 + 2L \tan \theta)^2} dL && \text{Expression 1} \\ &= \frac{4P}{\pi E} \left[-\frac{1}{2 \tan \theta} \times \frac{1}{(D_1 + 2L \tan \theta)} \right]_0^{L_0} \\ &= \frac{2P}{\pi E \tan \theta} \left[\frac{1}{D_1} - \frac{1}{(D_1 + 2L_0 \tan \theta)} \right] \\ &= \frac{4P}{\pi E} \frac{L_0}{D_1 (D_1 + 2L_0 \tan \theta)} \therefore \delta \\ &= \frac{4PL_0}{\pi E D_1 D_2}, \left(\tan \theta = \frac{D_2 - D_1}{2L_0} \right), \end{aligned}$$

[0098] wherein 'P' denotes a compressive stress, ' L_0 ' denotes a length (or height) of the spacer **150** or **170**, and 'E' denotes Young's modulus.

[0099] The compressed amount δ_{edge} of the spacers disposed at the edge is larger than the compressed amount

δ_{center} of the spacers disposed at the center so as to maintain a uniform cell gap ($\delta_{\text{edge}} < \delta_{\text{center}} + 0.1$).

[0100] The compressed amount δ_{center} is larger than compressed amount δ_{edge} by about $0.1 \mu\text{m}$. Thus, when δ_{edge} is smaller than $\delta_{\text{center}} + 0.1$ ($\delta_{\text{edge}} < \delta_{\text{center}} + 0.1$), the cell gap is maintained uniformly.

[0101] Thus, the following Expression 2 is induced.

$$\frac{1 < (D_{\text{center}1} \times D_{\text{center}2}) / (D_{\text{edge}1} \times D_{\text{edge}2}) < 1 + 0.1 (D_{\text{center}1} \times D_{\text{center}2})}{D_{\text{center}2}} \quad \text{Expression 2}$$

[0102] wherein $D_{\text{center}1}$ and $D_{\text{center}2}$ represent respectively upper and lower diameters of the spacer of the center, and $D_{\text{edge}1} \times D_{\text{edge}2}$ represent respectively upper and lower diameters of the spacer of the edge.

[0103] The multiplication of the diameters is directly proportional to the area of a contact face between the spacers **150** or **170** and the two substrates **120** or **130**. Thus, the Expression 3 may be induced from the Expression 2.

$$1 < A_{\text{center}} / A_{\text{edge}} < 1 + 0.1 A_{\text{center}} \quad \text{Expression 3}$$

[0104] wherein A_{center} denotes an area of contact face between the substrates and the spacer **150** or **170** disposed at the center, and A_{edge} denotes an area of contact face between the substrates and the spacer **150** or **170** disposed at the edge.

[0105] Thus, when a spacer satisfies Expression 2 or Expression 3, the cell gap is maintained uniformly, even though different compressive stress may be applied depending the region.

Embodiment 3

[0106] FIG. 5 is a cross-sectional view showing a liquid crystal display apparatus according to a third exemplary embodiment.

[0107] Referring to FIG. 5, each of spacers **180** has a same shape. However, a compression ratio of the spacers **180** is different from each other.

[0108] The spacers **180** have different polymer linking density. That is, the polymer linking density of the spacer **180** disposed at the center of the liquid crystal display panel is higher than that of the spacer **180** disposed at the edge.

[0109] The polymer linking density of the spacer **180** becomes higher in a direction from the center to the edge of the liquid crystal panel.

[0110] In order to adjust the polymer linking density of the spacer **180**, energy of exposure process is modulated. The spacers **180** are formed through a photolithography process. That is, a photoresist is coated on a first substrate **120** or on a second substrate **130**. Then, the photoresist is exposed with a mask disposed over the photoresist, and developed, so that the spacers **180** are formed. As the photoresist is exposed to a light having higher energy, the polymer linking density of the spacer **180** becomes higher. Thus, energy of the light becomes lower in a direction from the center to the edge, so that the polymer linking density of the spacers **180** becomes lower in the direction.

[0111] The spacer **180** disposed at the edge is more compressive than the spacer **180** disposed at the center, so

that the uniform cell gap is maintained, even though a compressive force of the center is stronger than that of the edge due to the self-weight.

[0112] FIG. 6 is a graph showing a relation between a compressive stress and an amount of compression for different energy of exposure process is applied.

[0113] In a simulation, a cylindrical shaped spacer has a height of about 4.5 μm and a diameter of about 2.5 μm .

[0114] As shown in the FIG. 6, as the compressive stress increases, an amount of compression increases. As energy of exposure process increases, the amount of compression decreases. That is, when the energy of exposure process increases, the spacers become stiffer.

[0115] The graph of compressive stress and the amount of compression is a hysteresis curve.

[0116] When the energy of exposure process is about 100 mJ, the amount of compression that corresponds to 5 gf compressive stress is about 0.746 μm . When the energy of exposure process is about 300 mJ, the amount of compression that corresponds to 5 gf compressive stress is about 0.62 μm . A difference in the amount of compression is about 0.13 μm . The energy difference of light of the center and the edge does not exceed about 200 mJ.

[0117] FIG. 7 is a graph showing a relation between energy of exposure process and an amount of compression (or Young's modulus).

[0118] Young's modulus is a compressive stress per a cross-sectional area of the spacer. Various elements change Young's modulus. In FIG. 7, the energy of exposure process is the element that changes Young's modulus.

[0119] As shown in FIG. 7, as the energy of exposure process becomes larger, Young's modulus becomes larger and the amount of compression becomes smaller.

[0120] Thus, in order to maintain a uniform cell gap, forming a spacer of the center needs light that has much energy than that of the edge.

[0121] Preferably, Young's modulus between the spacer of the center and the spacer of the edge does not exceed about 100 N/mm².

[0122] Referring again to FIGS. 2 and 5, a liquid crystal layer 140 may be formed before or after separating the liquid crystal panels 101, 102, 103 and 104 from the mother substrate 110.

[0123] Liquid crystal material may be injected between the first substrate 120 and the second substrate 130 via vacuum injection, after the liquid crystal panels 101, 102, 103 and 104 are separated from the mother substrate 110 according to dotted lines 'a' and 'b'.

[0124] The liquid crystal material may be dropped on the first substrate 120 or the second substrate 130, and the first and second substrates 120 and 130 are assembled, before the liquid crystal panels 101, 102, 103 and 104 are separated from the mother substrate 110.

[0125] The first substrate 120 corresponds to an array substrate (or thin film transistor substrate). The second substrate 130 corresponds to a color filter substrate.

[0126] The array substrate includes a gate line, a data line, a thin film transistor and a pixel electrode. The thin film transistor includes a gate electrode, a drain electrode and a source electrode. The gate electrode is electrically connected with the gate line. The source electrode is electrically connected with the data line. The drain electrode is electrically connected with the pixel electrode.

[0127] A scan signal is transferred to the gate electrode of the thin film transistor via the gate line. An image signal is transferred to the drain electrode via the data electrode. The image signal is applied to the pixel electrode.

[0128] The color filter substrate includes a common electrode and color filters. The color filters include a red-color filter, a green color filter and blue-color filter.

[0129] The color filter and the common electrode may be formed on the array substrate.

Embodiment 4

[0130] FIG. 8 is a layout showing a portion of a thin film transistor substrate of a liquid crystal display apparatus according to a fourth exemplary embodiment of the present invention, and FIG. 9 is a cross-sectional view taken along a line B-B' of FIG. 8.

[0131] Referring to FIGS. 8 and 9, a gate wiring and a storing line 220 are formed on a first transparent substrate 120. The gate wiring includes a conducting layer that has a high electric conductivity. The gate line 237 and the storing line 220 are tapered.

[0132] The gate wiring includes a gate line 230, a gate pad (or end of the gate line) 235 and the gate electrode 237. The gate line 230 is elongated in a first direction. The gate pad 235 is formed at an end portion of the gate line 230. The gate electrode 237 protrudes from the gate line 230.

[0133] A protrusion of the gate line 230 that overlaps with a pixel electrode 240 may be used as one conductor of an electric condenser so as to store electric charges, so that the storing line 220 may not be formed. In case of a shortage of an electric capacitance, a wiring for storing electric charges may be equipped separately.

[0134] A gate insulation layer 250 comprising silicon nitride (SiNx) is formed on the first transparent substrate 120 to cover the storing line 220 and the gate pad 235.

[0135] A semiconductor layer 260, such as an amorphous silicon layer is formed on a portion of the gate insulation layer 250, such that the semiconductor layer 260 is disposed over the gate electrode 237.

[0136] A contact resistance layers 273 and 276 comprising an amorphous silicon layer having n-type dopants or silicide (n+a-SiNx:H) are formed on the semiconductor layer 260.

[0137] The data wiring comprising high electric conductive material is formed on the contact resistance layer 273 and 276. The data wiring is elongated in a second direction that is substantially perpendicular to the first direction. The data wiring includes a data line 280, a source electrode 283, a data pad 287 and a drain electrode 286. A pixel is defined by one data line 280 and one gate line 230. The data pad 287 is formed at one end of the data wiring. An image signal is applied to the data pad 287 via the data pad 287. The drain electrode 286 is spaced apart from the source electrode 283.

The data wiring overlaps with the storing line **220** so as to enhance an electric capacitance. The data wiring may be one conductor of a capacitor for maintaining electric charges. The capacitor is electrically connected with a pixel electrode **240**. The data wiring does not cover the semiconductor layer **260**.

[0138] A protection layer **290** is formed on the data wiring and the semiconductor layer **260**. The protection layer **290** may be easily leveled. The protection layer **290** comprises an organic material or a material that has a low dielectric constant, such as a-Si:C:O:H.

[0139] The protection layer **290** may further include an insulation layer comprising silicon nitride. Preferably, when the protection layer **290** includes the insulation layer, the protection layer **290** is disposed under the organic material, such that the insulation layer makes contact with the semiconductor layer **260**.

[0140] A portion of the organic material is not disposed on the gate pad **235** and the data pad **287** so as to be electrically connected to external device for driving the gate driving circuit and the data driving circuit or to a circuit mounted on the first transparent substrate **120**.

[0141] The protection layer **290** includes contact holes **302** and **305**. The contact holes **302** and **305** expose the drain electrode **286** and the data pad **287** respectively. A contact hole **307** exposes the gate insulation layer **250** and the gate pad **235**.

[0142] The pixel electrode **240** is formed on the protection layer **290**. The pixel electrode **240** is disposed in the display region. The pixel electrode **240** is electrically connected with the drain electrode **286** via the contact hole **302**. The pixel electrode **240** comprises indium tin oxide (ITO) or indium zinc oxide (IZO). The indium tin oxide and the indium zinc oxide are electrically conductive and transparent.

[0143] A sub gate pad **312** and a sub data pad **317** are electrically connected with the gate pad **235** and the data pad **287** via the contact holes **302** and **305**, respectively. The sub gate pad **312** and the sub data pad **317** are not essential. The sub gate pad **312** and the sub data pad **317** protect the gate pad **235** and the data pad **287** respectively.

[0144] A black matrix **420** is formed on a second transparent substrate **410** of the color filter substrate **400** that faces the array substrate **100**. A color filter **430** is formed on the second transparent substrate **410**. The color filter **430** faces the pixel electrode **240** of the array substrate **100**. The color filter **430** includes a red-color filter, a green-color filter and a blue color filter. A common electrode **440** is formed on the color filter **430** and the black matrix **420** to cover them.

[0145] A liquid crystal layer **500** and spacers **150** are interposed between the array substrate **100** and the color filter substrate **400**. The spacers **150** maintain a cell gap (or a distance between the array substrate **100** and the color filter substrate **400**).

[0146] The spacers **150** may be one of the spacer disclosed in the above embodiments and combinations of the embodiments.

[0147] Liquid crystal molecules of the liquid crystal layer **500** have positive dielectric constant anisotropy. When the

liquid crystal display panel corresponds to twisted nematic mode, the liquid crystal molecules are twisted to form a helical shape. When the liquid crystal display panel corresponds to vertical alignment mode, the liquid crystal molecules are erected with reference to the array substrate **100** and the color filter substrate **400**. When the liquid crystal display panel corresponds to optically compensated birefringence mode, the liquid crystal molecules symmetrically arranged with reference to a center of the array substrate **100**.

[0148] FIG. 10 is a cross-sectional view showing a liquid crystal display apparatus according to a fourth exemplary embodiment of the present invention.

[0149] In FIG. 9, the spacers **150** are formed on the array substrate **100**. However, the spacers **150** may be formed on the color filter substrate **400** as shown in FIG. 10.

[0150] Referring to FIG. 10, the spacers **150** are disposed over the black matrix **420** that faces the gate line **230** or the thin film transistor, so that the black matrix **420** conceals the spacers **150**.

[0151] FIG. 11 is a schematic view showing an arrangement of spacers according to a fifth exemplary embodiment of the present invention.

[0152] Referring to FIG. 1, the spacers **150** are spaced apart from each other. The spacers **150** are disposed between color filters including a red color filter R, a green color filter G and a blue color filter.

Embodiment 5

[0153] Hereinafter, a method of manufacturing a liquid crystal display panel according to a fifth embodiment of the present invention is explained.

[0154] Referring to FIGS. 1 through 11, the gate wiring, the data wiring, the thin film transistor and the pixel electrode are formed on the array substrate **100** of the liquid crystal display panel **110**. An organic material is coated and patterned to form the spacers **150**. The spacers **150** may have different tapered angle, different contact area, or different polymer linking density.

[0155] The red, green and blue color filters **430** and the common electrode **440** are formed on the second transparent substrate **410**. The color filters **430** and the common electrode **440** may be formed on a same substrate with the thin film transistor.

[0156] The array substrate **100** that includes spacers **150** formed thereon is larger than the color filter substrate **400** by about 10%-30%.

[0157] The spacers **150** may be formed on the color filter substrate **400**.

[0158] When the spacers **150** are formed via a photolithography process, the spacers may be arranged in a specific position, and the distance between the spacers **150** is uniform.

[0159] Further, the spacers **150** may be formed to have short height, so that the cell gap may be small. Further, the spacers **150** are not formed on the pixel electrode to enhance the display quality.

[0160] A fence 160 is formed on the array substrate 100 or the color filter substrate 200 having the spacers 150 formed thereon. The fence 160 is a closed curve that has no opening for liquid crystal material injection. The fence 160 may be hardened, when ultraviolet rays are irradiated or heated. The fence 160 may include a spacer that maintains the cell gap.

[0161] The fence 160 does not include the opening for liquid crystal material injection, so that adjusting an amount of the liquid crystal material is important. The fence 160 may include a buffer region for overflowing liquid crystal material. The fence 160 may include a protection film that prevents a reaction between the fence 160 and the liquid crystal material. The protection film is formed on a portion of the fence 160, where the liquid crystal material makes contact with the fence 160.

[0162] The liquid crystal material is dropped on the array substrate 100 or on the color filter substrate 200 including the fence 160 formed thereon. The liquid crystal material may be injected by a syringe or sprayed by a sprayer.

[0163] Then, the array substrate 100 and the color filter substrate 400 are transferred to a vacuum chamber of an assembler. The array substrate 100 and the color filter substrate 400 are compressed. Then, ultraviolet rays are irradiated on the fence 160 to harden the fence 160. Thus, the liquid crystal display panel 110 is completed. While irradiating the ultraviolet rays, an alignment of the array substrate 100 and the color filter substrate 400 is adjusted minutely. The fence 160 has a little flexibility. Although the fence 160 and a spacer 150 mixed with the fence 160 support an edge portion of the array substrate 100 and the color filter substrate 400, the spacers 150 support the center portion of the array substrate 100 and the color filter substrate 400. The spacers 150 are more flexible than the fence 160.

[0164] The spacers 150 may be tapered, such that a tapered angle of the spacers 150 becomes larger in a direction from a center of the liquid crystal display panel 101 to an edge of the liquid crystal display panel 101. However, a difference of the tapered angle between the spacer 150 of the edge and the spacer 150 of the center is less than about 40°.

[0165] A diameter of the spacers 150 may become smaller in a direction from the center to the edge.

[0166] A polymer linking density of the spacers 150 may become higher in a direction from the center to the edge. Preferably, Young's modulus between the spacer of the center and the spacer of the edge does not exceed about 100 N/mm².

[0167] Thus, a uniform cell gap may be maintained between the center portion of the liquid crystal display panel 101 and the edge portion of the liquid crystal display panel 101.

[0168] Then, each of the liquid crystal display panels 101, 102, 103 and 104 is separated from the mother substrate 110.

Embodiment 6

[0169] FIG. 12 is a cross-sectional view showing a liquid crystal display apparatus according to a sixth exemplary embodiment of the present invention.

[0170] Referring to FIG. 12, a liquid crystal display apparatus 600 includes a first substrate 700, a second substrate 800, a liquid crystal 900 and spacers 1000.

[0171] FIG. 13 is a schematic view showing a thin film transistor substrate of FIG. 12.

[0172] Referring to FIG. 13, the first substrate 700 includes a first transparent substrate 710, pixel electrodes 720, a thin film transistor 730, a gate line 740 and a data line 750.

[0173] A glass substrate that has high transmissivity may be used as the first transparent substrate 710.

[0174] The pixel electrodes 720 are formed on the first transparent substrate 710, such that the pixel electrodes 720 are arranged in a matrix shape. For example, an area of each of the pixel electrodes 720 of 17 inch liquid crystal display panel is about 88 μm × 264 μm .

[0175] When a gate signal is applied to the thin film transistor 730 via the gate line 740, the thin film transistor is turned on. Then, a pixel voltage corresponding to an image is applied to each of the pixel electrodes 720.

[0176] The thin film transistor 730 includes a gate electrode 731, a source electrode 733, a drain electrode and a channel layer 736.

[0177] The gate electrode 731 is formed on the first transparent substrate 710. The gate electrode 731 is electrically insulated from the channel layer 736.

[0178] The drain electrode 736 and the source electrode 733 are spaced apart, so that the drain electrode 736 and the source electrode 733 are electrically insulated from each other. The drain electrode 736 and the source electrode 733 are formed on the channel layer 736.

[0179] The gate line 740 is electrically connected with the gate electrode 731 to form a channel in the channel layer 736 of the thin film transistor 730.

[0180] A threshold voltage V_{th} for forming the channel is applied to the gate line 740.

[0181] The data line 750 is electrically connected with source electrode 733 of the thin film transistor 730. The drain electrode 735 is electrically connected with the pixel electrode 720. Thus, when the thin film transistor 730 is turned on, the data line 750 is electrically connected with the pixel electrode 720.

[0182] FIG. 14 is a schematic view showing a color filter substrate of FIG. 12.

[0183] Referring to FIG. 14, the second substrate 800 includes a second transparent substrate 810, a color filter 820 and a common electrode 830. The second substrate 800 faces the first substrate 700 of FIG. 13.

[0184] A glass substrate that has high transmissivity may be used as the second transparent substrate 810. The color filter 820 may be formed on the second transparent substrate 810.

[0185] The color filter 820 includes a red-color filter 822, a green-color filter 824 and a blue color filter 826. A light having a wavelength that corresponds to red-color passes through the red-color filter 822. A light having a wavelength that corresponds to green-color passes through the green-color filter 824. A light having a wavelength that corresponds to blue-color passes through the blue-color filter 826.

[0186] The common electrode **830** is coated on the second transparent substrate **810** to cover the color filter **820**. The common electrode **830** faces the pixel electrode **720** of the first substrate **700**.

[0187] The first and second substrates **700** and **800** are assembled with each other, when the liquid crystal **900** is injected.

[0188] When the cell gap is uniform, the liquid crystal display apparatus **600** displays a high quality image.

[0189] The spacers **1000** are interposed between the first and second substrates **700** and **800**, so that the spacers **1000** maintain the cell gap.

[0190] The spacers **1000** correspond to a rigid spacer. A photoresist are coated and patterned, so that the rigid spacer is formed.

[0191] FIG. 15 is a cross-sectional view showing spacers formed on a color filter substrate of FIG. 12.

[0192] Referring to FIGS. 12 and 15, spacers **1000** are formed over the second substrate **800**. In FIG. 15, only three spacers **1000** are illustrated for example, about 1000,000 numbers of spacers are formed over the second substrate **800** for 17 inch liquid crystal display apparatus **600**. The spacers **1000** are arranged in a matrix shape.

[0193] The spacers **1000** are formed over the second substrate **800**, such that the spacers **1000** are disposed between the pixel electrodes **720**, when the first and second substrates **700** and **800** are assembled with each other. Thus, the spacers **1000** do not deteriorate the display quality.

[0194] The spacer **1000** has a column shape having a first contact face **1020** and a second contact face **1010**. The first contact face **1020** makes contact with the first substrate **700**. The second contact face **1010** makes contact with the second substrate **800**.

[0195] The spaces **1000** are compressed, when an external compressive stress is applied to the spacers **1000**. Thus, the cell gap is reduced when the external compressive stress is applied to the liquid crystal display apparatus **600**.

[0196] The external compressive stress corresponds to an atmospheric pressure and a pressure caused by self-weight.

[0197] FIG. 16 is a graph showing a relation between amount of compression and a position.

[0198] Generally, when the second substrate **800** is disposed over the first substrate **700**, the compressive stress caused by the atmospheric pressure is equally applied to overall area of the second substrate **800**, as shown in graph 'B'.

[0199] The compressive stress caused by the self-weight is maximal at the center 'E' of the second substrate **800**. The compressive stress caused by the self-weight is minimal at the edges 'D' and 'F' of the second substrate **800**.

[0200] The compressive stress becomes smaller in a direction from the center 'E' to the edges 'D' and 'F', as shown in graph 'A'.

[0201] Thus, a total compressive stress becomes smaller in the direction from the center 'E' to the edges 'D' and 'F'.

[0202] When same spacers are formed at the center portion and the edge portion, the center portion of the second substrate **800** sags to form a U-shape. Thus, the cell gap of the center is smaller than that of the edge. That induces a deterioration of the display quality.

[0203] The spacers may be formed, such that the spacer disposed at the center portion has a larger diameter than the spacer disposed at the edge portion.

[0204] In case a distance between the pixel electrodes is too small, adjusting the diameter of the spacer meets a limitation.

[0205] Thus, a shape of the spacers may be adjusted so as to maintain the uniform cell gap, while not changing the diameter of the spacer.

[0206] Referring again to FIG. 15, the spacer **1000** disposed at the center portion 'E' has different shape from the spacer **1000** disposed at the edge portions 'D' and 'F'.

[0207] For example, the first contact face **1020** of the spacers **1000** disposed at the edge portions 'D' and 'F' is smaller than the first contact face **1020** of the spacers **1000** disposed at the center portion 'E'. However, the second contact face **1010** of the spacers **1000** disposed at the edge portions 'D' and 'F' is substantially equal to the first contact face **1020** of the spacers **1000** disposed at the center portion 'E'.

[0208] An area of the first contact face **1020** may be easily calculated from an external compressive stress, Young's modulus and the height of the spacers **1000**.

[0209] The area of the first contact face **1020** of the spacers gradually decreases in the direction from the center portion 'E' of the second substrate **800** to the edge portion 'D' and 'F' of the second substrate **800**. Thus, even though the compressive stress becomes weaker in the direction from the center portion 'E' to the edge portion 'D', the cell gap is maintained uniformly.

[0210] FIGS. 17A to 17C are perspective views showing spacers formed in an edge portion of a color filter substrate.

[0211] Referring to FIGS. 17A-17C, spacers formed in an edge portion may have a truncated cone shape, a frustum of rectangular pyramid shape, a frustum of hexagonal pyramid shape etc., so that the first contact face **1020** is smaller than the second contact face **1010**.

[0212] FIGS. 18A to 18C are perspective views showing spacers formed in a center portion of a color filter substrate.

[0213] Referring to FIGS. 15 and 18A to 18C, the spacers formed in a center portion of the second substrate **800** may have a cylindrical shape, a rectangular prism shape, a hexagonal prism shape. etc. Thus, the area of the first contact face **1020** is maximum at the center of the second substrate **800**. The area of the first contact face **1020** is substantially equal to the area of the second contact face **1010**.

[0214] A ratio of the first contact face **1020** to the second contact face **1010** (the first contact face **1020**/the second contact face **1010**) of the spacers formed at the second substrate **800** may gradually decrease according to the compressive stress applied to the second substrate **800** due to the self-weight.

[0215] Thus, the cell gap of the first and second substrate **700** and **800** is maintained uniformly.

[0216] FIG. 19 is a schematic plan view showing spacers and fence formed on a color filter substrate.

[0217] Referring to FIG. 19, a fence **850** is formed on an edge portion of the second substrate **800**, after the spacers **1000** are formed on the second substrate **800**.

[0218] The fence **850** comprises a mater that is hardened, when ultraviolet rays are irradiated onto the mater. Thus, the fence **850** is hardened, when the ultraviolet rays are irradiated onto the fence **850**. The fence **850** has a closed curve shape, so that the fence **850** and the second substrate **800** form a space for receiving the liquid crystal **900**.

[0219] Referring again to FIG. 12, the liquid crystal **900** is dropped in the space.

[0220] When the liquid crystal **900** is filled, the second substrate **800** is assembled with the first substrate **700**. Then, the ultraviolet rays are irradiated onto the fence **850** to harden the fence **850**, so that the first and second substrates **700** and **800** are assembled tightly with each other.

[0221] Hereinafter, a method of manufacturing the first substrate **700** of the liquid crystal display apparatus is explained.

[0222] FIG. 20 is a cross-sectional view showing a process of manufacturing a thin film transistor substrate of a liquid crystal display apparatus according to a sixth exemplary embodiment of the present invention.

[0223] Referring to FIG. 20, thin film transistors **730** are formed on the first transparent substrate **710**. Each of the thin film transistors **730** includes a gate electrode **731**, a source electrode **733**, a drain electrode **735** and a channel layer **736**.

[0224] The thin film transistors **730** are arranged in a matrix shape on the first transparent substrate **710**.

[0225] A pixel electrode **720** is electrically connected to the drain electrode **735**. The pixel electrode **720** comprises an indium tin oxide (ITO) or indium zinc oxide (IZO). The indium tin oxide (ITO) or indium zinc oxide (IZO) is transparent and electrically conductive.

[0226] FIG. 21 is a cross-sectional view showing a process of manufacturing a color filter substrate of a liquid crystal display apparatus according to a sixth exemplary embodiment of the present invention.

[0227] Referring to FIG. 21, a red color filter **822**, a green color filter **824** and a blue color filter **826** is arranged alternatively. The color filters are arranged in a matrix shape.

[0228] A common electrode **830** is formed on the color filters. The common electrode **830** comprises the indium tin oxide (ITO) or indium zinc oxide (IZO).

[0229] FIG. 22 is a cross-sectional view showing a process of manufacturing spacers according to a sixth exemplary embodiment of the present invention.

[0230] Referring to FIG. 22, a photoresist material is coated on the common electrode **830** to form a photoresist thin film **840**. A spin coating method may be used, when coating the photoresist thin film on the common electrode **830**.

[0231] The photoresist thin film **840** is firstly cured via soft baking.

[0232] Then, a pattern mask is aligned over the photoresist thin film **840**. The pattern mask includes a pattern that corresponds to a spacer. The photoresist thin film **840** is exposed and developed, so that the spacer is formed.

[0233] FIG. 23 is a cross-sectional view showing spacers formed on a color filter substrate according to a sixth exemplary embodiment of the present invention.

[0234] Spacers **1000** are spaced apart from each other. The spacers **1000** are disposed, such that the spacers **1000** are disposed between pixel electrodes **720**, when first and second substrates are assembled together.

[0235] The pattern of the pattern mask of FIG. 22 is different from each other, so that shapes of the spacers **1000** are different from each other. The pattern mask is adjusted to form the spaces as shown in FIG. 23.

[0236] Each of the spacers **1000** has first and second contact faces **1020** and **1010**. The shapes of the spacers **1000** are modulated in a direction from a center of the second transparent substrate **810** to an edge of the second transparent substrate **810**.

[0237] In detail, an area of the first face **1020** of the spacers gradually decreases in a direction from the center of the second transparent substrate **810** to the edge of the second transparent substrate **810**, while an area of the second face **1010** is maintained.

[0238] The spacers **1000** disposed on the edge portion of the second transparent substrate **810** may have a circular truncated cone shape, a frustum of rectangular pyramid shape, a frustum of hexagonal pyramid shape, etc., as shown in FIGS. 17A to 17C.

[0239] An area of the first and second contact faces **1020** and **1020** of a spacer **1099** disposed at the center of the second transparent substrate **810** is the same.

[0240] The spacer **1099** disposed at the center of the second transparent substrate **810** may have a cylindrical shape, a rectangular prism shape, a hexagonal prism shape, etc., as shown in FIGS. 18A to 18C.

[0241] FIG. 24 is a cross-sectional view showing a liquid crystal filled in a space formed by a fence and a color filter substrate cross-sectional view showing a process of manufacturing spacers according to a sixth exemplary embodiment of the present invention.

[0242] Referring to FIG. 24, when spacers **1000** are formed on the second substrate **800**, a fence **850** may be formed on a first substrate **700** or the second substrate **800**.

[0243] Then, liquid crystal **900** is dropped and filled in a space defined by the fence **850**.

[0244] For example, the fence **850** is formed on the second substrate **800**.

[0245] Referring again to FIG. 12, when the liquid crystal **900** is filled in the space defined by the fence **850**, the first substrate **700** is assembled with the second substrate **800** to form the liquid crystal display apparatus. The cell gap or the distance between the first substrate **700** and the second substrate **800** is less than about 0.15 μm .

Embodiment 7

[0246] FIG. 25 is a cross-sectional view showing a liquid crystal display apparatus according to a seventh embodiment of the present invention.

[0247] Referring to FIG. 25, a liquid crystal display apparatus 1500 includes a first substrate 1000, a second substrate 1400, spacers 1200 and a liquid crystal layer 1300.

[0248] The spacers 1200 and the liquid crystal layer 1300 are disposed between the first substrate 1000 and the second substrate 1400. The spacers 1200 maintain the cell gap (or the distance between the first substrate 1000 and the second substrate 1400).

[0249] FIG. 26 is a schematic plan view showing a color filter substrate of a liquid crystal display apparatus of FIG. 25.

[0250] Referring to FIGS. 25 and 26, the first substrate 1000 includes a transparent substrate 1110, a black matrix 1120, a color filter 1130, a first electrode (or a common electrode) and a sealing wall (or fence) 1150.

[0251] The transparent substrate 1110 supports the black matrix 1120, a color filter 1130 and a first electrode 1140.

[0252] The black matrix 1120 comprises Chromium (Cr) or Chromium oxide (CrO_2).

[0253] Chromium (Cr) or Chromium oxide (CrO_2) are coated on the transparent substrate 1110 and patterned to form the black matrix 1120. The black matrix 1120 has a lattice-shape.

[0254] The black matrix 1120 prevents a light from leaking via a portion disposed between color filters 1130.

[0255] The color filters 1130 are enwrapped with the black matrix 1120. The color filters 1130 includes a red color filter 1132, a green color filter 1134 and a blue color filter 1136. The red color filter 1132 filters a white light, so that only a light that has a wavelength corresponding to the red color may pass through the red color filter 1132.

[0256] The green color filter 1134 filters a white light, so that only a light that has a wavelength corresponding to the green color may pass through the green color filter 1134.

[0257] The blue color filter 1136 filters a white light, so that only a light that has a wavelength corresponding to the blue color may pass through the blue color filter 1136.

[0258] An edge of the color filters 1130 overlaps with the black matrix 1120, such that the edge of the color filters 1130 is disposed on the black matrix 1120.

[0259] The first electrode 1140 is formed on the color filters 1130, such that the first electrode 1140 covers the whole region of the transparent substrate 1110.

[0260] A reference voltage is applied to the first electrode 1140.

[0261] FIG. 27 is a cross-sectional view taken along a line C-C' of FIG. 26.

[0262] Referring to FIGS. 26 and 27, spacers 1200 are formed to have a first height H1. The spacers 1200 are disposed over the black matrix 1120.

[0263] The spacers 1200 may have a cylindrical shape, so that the spacers 1200 have a cylindrical surface, a first contact face 1210 and a second contact face 1220. The first contact face 1210 is parallel to the second contact face 1220.

[0264] The spacers 1200 make contact with the first electrode 1140 via the first contact face 1210.

[0265] The first height H1 of the spacers 1200 is larger than an allowable liquid crystal cell gap H2.

[0266] When the first height H1 is smaller than the allowable liquid crystal cell gap H2, the spacers 1200 may not maintain the distance between the first and second substrate 1100 and 1400.

[0267] When the first and second substrate 1100 and 1400 are assembled with each other, the spacers 1200 are compressed to have height that is substantially equal to H2.

[0268] An amount of compression of the spacers 1200 is determined by a factor such as a cross-sectional area of the spacers 1200, a count (or number) of the spacers 1200 and Young's modulus.

[0269] When Young's modulus is constant, the cross-sectional area and the count of spacers 1200 determine the amount of compression.

[0270] Firstly, the spacers 1200 are formed on the first electrode 1140 disposed on the black matrix 1120, such that the spacers 1200 one-to-one correspond to the color filter 1130 so as to determine to the cross-sectional area of the spacers 1200.

[0271] When the cross-sectional area is determined, the counter of the spacers may be adjusted according to the cross-sectional area.

[0272] In case that the cross-sectional area of the spacers 1200 is too small, the spacers 1200 are compressed so much that the spacers 1200 apply strong force to the first substrate 1100, so that the first electrode 1140, the spacers 1200 or the black matrix 1120 may be broken.

[0273] In case that the cross-sectional area of the spacers 1200 is too large, the spacers 1200 are compressed so little that the spacers 1200 are not compressed to the allowable liquid crystal cell gap H2. Thus, unfilled region is formed, which is not preferable. The unfilled region induces a critical deterioration of display quality.

[0274] Thus, determining the cross-sectional area and density of the spacers 1200 is important.

[0275] Hereinafter, a method of determining the cross-sectional area and density of the spacers 1200 is explained.

[0276] The cross-sectional area of the spacers 1200 is obtained by computer simulation. In order to obtain the cross-sectional area of the spacers 1200, a comparative liquid crystal display panel is used.

[0277] For example, the comparative liquid crystal display panel is a 17 inch super extended graphics array (SXGA) liquid crystal display panel. A size of a color filter of the comparative liquid crystal display panel is about $88\ \mu\text{m} \times 264\ \mu\text{m}$. The size of a pixel is substantially equal to the size of the color filter. A width of the black matrix of the comparative liquid crystal display panel is in a range from about $12\ \mu\text{m}$ to about $32\ \mu\text{m}$, so that the color filters are spaced apart

from each other by about $12\ \mu\text{m}$ - $32\ \mu\text{m}$. In the comparative liquid crystal display panel, one spacer per twelve color filters is formed. The cross-sectional area of the spacer is about $500\ \mu\text{m}^2$.

[0278] The spacer has a cylindrical shape, so that a diameter of the spacer is about $25.2\ \mu\text{m}$. The Young's modulus of the spacer is about $487\ \text{N}/\text{mm}^2$.

[0279] When spacers are formed, such that the spacers one-to-one correspond to the color filter, a size of the spacer may be obtained by dividing $500\ \mu\text{m}^2$ by 12 to get about $41.7\ \mu\text{m}^2$.

[0280] That is, in case that the spacers are formed, such that a count of the spacers is equal to the number of the color filter, the area of the spacer is about $41.7\ \mu\text{m}^2$.

[0281] With the comparative liquid crystal display panel, the cross-sectional area of the spacer and the density of the objective liquid crystal display panel may be obtained.

[0282] In a macroscopic view, increasing the density of the spacer is similar to increasing the cross-sectional area of the spacer in effect.

[0283] A stiffness factor 'A' is introduced and defined by following Expression 4. The stiffness factor means a degree of transformation of the spacer.

$$A = a \times B \times C, \quad \text{Expression 4}$$

[0284] wherein 'A' denotes the stiffness factor, 'a' denotes a compensating constant defined by (area of color filter of comparative liquid crystal display panel)/(area of color filter of objective liquid crystal display panel), 'B' denotes the cross-sectional area of the spacer, and 'C' denotes the density of the spacer (or the count of the spacer per color filter).

[0285] For example, in case that one spacer is formed per twelve color filters, 'C' is $1/12$.

[0286] Young's modulus of the spacer is about $487\ \text{N}/\text{mm}^2$.

[0287] In Expression 4, a value of $B \times C$ is preserved. That is, when 'B' increases, 'C' decreases. When 'C' increases, 'B' decreases. In other words, when the density of the spacers increases, the cross-sectional area of the spacers decreases.

[0288] Thus, the area of a total contact region between the spacers and the first or second substrate is fixed.

[0289] The compensating constant 'a' compensates a difference between the comparative liquid crystal display panel and the objective liquid crystal display panel. In case that the size of the objective liquid crystal display panel is substantially equal to the size of the comparative liquid crystal display panel, the compensating constant 'a' is equal to 1.

[0290] When the size of the objective liquid crystal display panel is larger than the size of the comparative liquid crystal display panel, the compensating constant 'a' is smaller than 1. When the size of the objective liquid crystal display panel is smaller than the size of the comparative liquid crystal display panel, the compensating constant 'a' is larger than 1.

[0291] As the compensating constant 'a' becomes smaller, the stiffness factor 'A' becomes smaller. As the compensating constant 'a' becomes larger, the stiffness factor 'A' becomes larger.

[0292] For example, in case that the area of the color filter of the objective liquid crystal display panel having 40 inch size is $227\ \mu\text{m} \times 68\ \mu\text{m}$ and the area of the comparative liquid crystal display panel is $88\ \mu\text{m} \times 264\ \mu\text{m}$, the compensating constant a_{40} is about 0.15 that is obtained by dividing (88×264) by (227×681) .

[0293] Thus, the stiffness factor 'A' becomes smaller.

[0294] The cross-sectional area of the spacer 'B' may be determined by considering the distance between the color filters. A diameter of the spacer may be less than the distance between the color filters. In case that the diameter of the spacer is larger than the distance, the spacer invades the color filter, so that the display quality is lowered.

[0295] For example, when the distance between the color filters is in a range from about $30\ \mu\text{m}$ to about $45\ \mu\text{m}$, a diameter 'D' of the spacer may be $35\ \mu\text{m}$ that is less than $45\ \mu\text{m}$ preferably. Then, the cross-sectional area of the spacer 'B' is about $800\ \mu\text{m}^2$ that is obtained from $[\pi \times (D/2)^2]$.

[0296] Thus, when the stiffness factor 'A', the compensating constant 'a' and the cross-sectional area 'B' is determined, the density 'D' of the spacer may be obtained from Expression 4. The stiffness factor 'A' is determined, such that the first and second substrates are not broken and the unfilled region is not formed.

[0297] Hereinafter, a method of determining the stiffness factor 'A' is explained.

[0298] FIG. 28A is a graph showing a relation between a cell gap and a stiffness factor, when a Young's modulus is about $487\ \text{N}/\text{mm}^2$.

[0299] The graph was obtained by simulation.

[0300] Referring to FIG. 28A, when a stiffness factor is in a range from about $0\ \mu\text{m}^2$ to about $30\ \mu\text{m}^2$, a cell gap increases rapidly. When the stiffness factor is larger than about $30\ \mu\text{m}^2$, the cell gap increases slowly.

[0301] A liquid crystal display apparatus of twisted nematic liquid crystal, a thickness of the liquid crystal layer is about $4.65\ \mu\text{m}$. When the thickness of the liquid crystal layer is over $4.75\ \mu\text{m}$, the liquid crystal display apparatus is treated as a malproduct due to poor display quality.

[0302] Thus, an allowable maximal cell gap is $4.75\ \mu\text{m}$. The stiffness factor corresponding to the allowable maximal cell gap is about $76\ \mu\text{m}^2$.

[0303] Thus, the cell gap is designed, such that the stiffness factor is less than $76\ \mu\text{m}^2$.

[0304] In a vertical alignment mode, the maximum allowable cell gap may be obtained by the graph of FIG. 28A.

[0305] When the stiffness factor is over about $76\ \mu\text{m}^2$, the spacer is too stiff. Thus, the spacer is seldom compressed, when the first and second substrate are assembled together. When the spacer is not compressed until the spacer has a height that is substantially equal to the allowable liquid crystal cell gap H2 of FIG. 27, a liquid crystal display panel includes an unfilled region. Thus, the display quality is lowered. The unfilled region corresponds to a hatched region.

[0306] According to the graph of FIG. 28A, when the stiffness factor is less than about $76\ \mu\text{m}^2$, the liquid crystal display device includes no unfilled region.

[0307] As a compression ratio increases, a compressive stress applying to the first and second substrate increases.

[0308] FIG. 28B is a graph showing a relation between a compression ratio and a stiffness factor, when a Young's modulus is about 487 N/mm².

[0309] Referring to FIG. 28B, as a stiffness factor decreases, a compression ratio increases. As the stiffness factor increases, the compression ratio decreases.

[0310] When the compression ratio is over about 15%, a spacer may damage the first and second substrates, in case of Young's modulus of the spacer is about 487 N/mm².

[0311] The compression ratio of 15% means that a spacer having 100 μm height is compressed to have 85 μm height for example.

[0312] The stiffness factor corresponding to the compression ratio of 15% is about 32 μm². The stiffness factor is inversely proportional to the compression ratio as shown in FIG. 28B. Thus, when the compression ratio less than about 15%, the stiffness factor is more than about 32 μm².

[0313] As a result of FIGS. 28A and 28B, in case of a Young's modulus of the spacer is about 487 N/mm², the stiffness factor 'A' of Expression 4, is in a range from about 32 μm² to about 76 μm².

[0314] The range of the stiffness factor may be adjusted according to the Young's modulus of the spacer.

[0315] FIG. 29A is a graph showing a relation between a cell gap (or a compression ratio) and a stiffness factor, when Young's modulus is about 243.5 N/mm².

[0316] Referring to FIG. 29A, when Young's modulus is lowered from about 487 N/mm² to about 243.5 N/mm², the stiffness factor corresponding to an upper limit of region where no unfilled region is formed increases from about 76 μm² to about 120 μm².

[0317] The stiffness factor corresponding to the compression ratio of 15%, that is corresponding to a lower limit of region where the first and second substrates are not damaged increases from about 32 μm² to about 66 μm².

[0318] Thus, the spacer is designed, such that the stiffness factor is in a range from about 66 μm² to about 120 μm², in case that the Young's modulus is about 243.5 N/mm².

[0319] Comparing with the previous result, when Young's modulus becomes a half, an upper limit and a lower limit of the range of the stiffness factor become double respectively.

[0320] FIG. 29B is a graph showing a relation between a cell gap (or a compression ratio) and a stiffness factor, when Young's modulus is about 974 N/mm².

[0321] Referring to FIG. 29B, when Young's modulus is increased from about 487 N/mm² to about 974 N/mm², the stiffness factor corresponding to an upper limit of region where no unfilled region is formed decreases from about 76 μm² to about 40 μm².

[0322] The stiffness factor corresponding to the compression ratio of 15%, that is corresponding to a lower limit of region where the first and second substrates are not damaged decreases from about 32 μm² to about 18 μm².

[0323] Thus, the spacer is designed, such that the stiffness factor is in a range from about 18 μm² to about 40 μm², in case that Young's modulus is about 974 N/mm².

[0324] Comparing with the previous result, when the Young's modulus becomes a double, an upper limit and a lower limit of the range of the stiffness factor become a half respectively.

[0325] In short, the range of the stiffness factor is changed, when Young's modulus is changed.

[0326] Thus, in order to compensate the difference of Young's modulus, the range of the stiffness factor is adjusted as the following Expression 5.

$$(Y_{com}/Y_{ob}) \times 32 \mu\text{m}^2 \leq A \leq (Y_{com}/Y_{ob}) \times 76 \mu\text{m}^2, \quad \text{Expression 5}$$

[0327] wherein Y_{com} denotes Young's modulus of a comparative liquid crystal display panel, and Y_{ob} denotes Young's modulus of an objective liquid crystal display panel.

[0328] In Expression 5, Young's modulus of the comparative liquid crystal display panel Y_{com} is 487 N/mm².

[0329] Referring again to FIG. 27, the spacers 1200 are formed on the first electrode 1140 by the stiffness factor, such that the spacers 1200 deviate from the color filters 1132, 1134 and 1136.

[0330] The spacer 1200 has a first height H1.

[0331] The liquid crystal is dropped and filled to have the depth corresponding to the allowable liquid crystal cell gap H2.

[0332] FIG. 30 is a schematic plan view showing a thin film transistor substrate according to a seventh exemplary embodiment of the present invention.

[0333] Referring to FIG. 30, a second substrate 1400 includes a transparent substrate 1410, a thin film transistor (not shown) and a second electrode 1420.

[0334] The second electrode 1420 faces the color filter 1130 of the first substrate 1100 of FIG. 27.

[0335] The second electrode 1420 is electrically connected with the thin film transistor.

[0336] The first substrate 1100 and the second substrate 1400 are assembled together, such that the second electrode 1420 of the second substrate 1400 faces the color filter 1130 of the first substrate 1100.

Embodiment 8

[0337] In order to manufacture a liquid crystal display apparatus of FIG. 25 according to an exemplary embodiment 8, a first height H1, a cross-sectional area and a density of the spacer 1200 are calculated. Then, the spacers 1200 are formed on a first substrate 1100 according to the calculated first height H1, cross-sectional area and density. The liquid crystal 1300 is provided to the first substrate 1100. The first substrate 1100 and the second substrate 1400 are assembled together.

[0338] The first height H1 of the spacers 1200 is higher than the allowable liquid crystal cell gap H2. The cross-sectional area of the spacers 1200 is designed, such that the

spacers **1200** having the first height **H2** may be compressed to a height corresponding to the allowable liquid crystal cell gap **H2**.

[0339] The cross-sectional area and the density of the spacers **1200** may be obtained from Expressions 4 and 5.

[0340] When the cross-sectional area and the density of the spacers **1200** may be obtained, the first substrate **1100** is formed.

[0341] FIGS. 31A to 31J are a schematic view showing a process of manufacturing a color filter substrate according to an eighth exemplary embodiment of the present invention.

[0342] FIG. 31A is a schematic cross-sectional view showing a chromium thin film formed on a transparent substrate.

[0343] Referring to FIG. 31A, a chromium (Cr) thin film **1125** is coated on one face of a transparent substrate **1110**. The chromium thin film **1125** may be coated on the transparent substrate **1110** by chemical vapor deposition (CVD) or a sputtering method.

[0344] FIG. 311B is a schematic cross-sectional view showing a process of manufacturing a photoresist pattern.

[0345] Referring to FIG. 31B, a photoresist is coated on a chromium thin film **1125** by a spin coating method or a slit coating method.

[0346] Then, a pattern mask **1127** is disposed over the transparent substrate **1110**. The pattern mask **1127** has a lattice shape.

[0347] FIG. 31C is a plan view showing a pattern mask of FIG. 32B.

[0348] Referring to FIG. 31C, the pattern mask **1127** includes a glass substrate **1128** and chromium pattern **1129**. The glass substrate **1128** is transparent. The chromium pattern **1129** is coated on the glass substrate **1128**. The chromium pattern **1129** includes openings **1129a**.

[0349] A light is incident onto the pattern mask **1127**. A first portion of the light that arrives at the openings **1129a** passes through the pattern mask **1127** to arrive at the photoresist. A second portion of light that arrives at the chromium pattern **1129** is intercepted by the chromium pattern **1129**.

[0350] The photoresist exposed to the light is removed. The photoresist that is not exposed to the light remains to form a photoresist pattern.

[0351] FIG. 31D is a schematic cross-sectional view showing a black matrix formed on a transparent substrate.

[0352] Referring to FIG. 31D, a first portion of the chromium is protected by the photoresist pattern. A second portion **1120** of the chromium is not protected by the photoresist pattern. The second portion **1121** of the chromium is etched, and the first portion of the chromium remains to form a black matrix. Hereinafter, a reference numeral **1120** corresponds to the black matrix, and a reference numeral **1121** corresponds to a groove formed by eliminating the second portion of the chromium.

[0353] The photoresist pattern on the black matrix is eliminated by ashing.

[0354] FIG. 31E is a schematic cross-sectional view showing a color filters formed on a transparent substrate, a first electrode formed on the color filters.

[0355] Referring to FIG. 31E, color filters **1130** are formed in the groove **1121**, such that an edge of the color filters **1130** overlaps with the black matrix **1120**.

[0356] The color filters **1130** includes a red color filter **1132**, a green color filter **1134** and a blue color filter **1136**.

[0357] A first electrode **1140** is formed on the color filters **1130**. The first electrode **1140** may be formed by chemical vapor deposition (CVD). The first electrode **1140** includes indium tin oxide (ITO) or indium zinc oxide (IZO). The indium tin oxide (ITO) and indium zinc oxide (IZO) are transparent and electrically conductive.

[0358] FIG. 31F is a schematic cross-sectional view showing a process of forming spacers on a first electrode.

[0359] Referring to FIG. 31F, a thin film **1210** is formed on the first electrode **1210**, such that a thickness of the thin film **1210** is about **H1** of FIG. 27. The thin film **1210** may be formed by spin coating method or slit coating method.

[0360] Young's modulus of the thin film **1210** determines Young's modulus of the spacer.

[0361] The thin film **1210** is photosensitive.

[0362] A pattern mask **1220** is disposed over the thin film **1210**.

[0363] FIG. 31G is a plan view of a pattern mask of FIG. 31F.

[0364] Referring to FIG. 31G, the pattern mask **1220** includes openings **1225** for forming spacers. An area of the openings **1225** is substantially equal to a cross-sectional area of the spacers.

[0365] A first portion of the thin film is exposed to a light, and a second portion of the thin film is not exposed to the light. The first portion of the thin film remains and the second portion of the thin film is eliminated, so that the spacers are formed.

[0366] FIG. 31H is a schematic cross-sectional view showing a process of dropping liquid crystal.

[0367] Referring to FIG. 31H, when spacers **1200** are formed on the first electrode **1140**, a dispenser **1310** drops liquid crystal **1300**, until a depth of the liquid crystal reaches to an allowable liquid crystal cell gap **H2**.

[0368] FIG. 31I is a cross-sectional view showing a thin film transistor and a color filter substrates assembled with each other to form a liquid crystal display panel.

[0369] Referring to FIG. 31I, when liquid crystal is filled at a first substrate (or a color filter substrate) **1100**, the first substrate **1100** is assembled with a second substrate (or a thin film transistor substrate) **1400**. The second substrate **1400** includes a thin film transistor and a second electrode **1410**.

[0370] The first and second substrates **1100** and **1400** are compressed, such that the spacers **1200** has a height that is substantially equal to the allowable liquid crystal cell gap **H2** of FIG. 31H.

[0371] FIG. 31J is a cross-sectional view showing a liquid crystal display panel having spacers of which one end is tapered.

[0372] Referring to FIG. 31J, spacers 1200 may have a tapered end.

[0373] Having described the exemplary embodiments of the present invention and its advantages, it is noted that various changes, substitutions and alterations can be made herein without departing from the spirit and scope of the invention as defined by appended claims.

What is claimed is:

1. A substrate for a liquid crystal display device, comprising:

a transparent substrate including a display region for displaying an image;

a plurality of spacers formed in the display region, the spacers having a gradually increasing compression ratio in a direction from a center of the display region to an edge of the display region.

2. The substrate of claim 1, wherein the substrate comprises a plurality of pixel electrodes, the spacers being formed such that the spacers deviate from the pixel electrodes.

3. The substrate of claim 1, wherein the substrate comprises a black matrix and a common electrode, the spacers being formed such that the spacers are disposed over the black matrix.

4. The substrate of claim 1, wherein the spacers are tapered, a side face of the spacer and the transparent substrate forming a tapered angle, the tapered angle of the spacers gradually increasing in the direction, a product of an upper diameter and a lower diameter of the spacers decreasing in the direction.

5. The substrate of claim 4, wherein a difference of the tapered angle of the spacer disposed at the edge and the tapered angle of the spacer disposed at the center is no more than about 40°.

6. The substrate of claim 1, wherein the spacers are tapered, such that a tapered angle is constant, a side face of the spacer and the transparent substrate forming the tapered angle, a diameter of the spacers decreasing in the direction.

7. The substrate of claim 1, wherein a polymer linking density of the spacers decreases in the direction.

8. The substrate of claim 1, wherein Young's modulus of the spacers decreases in the direction.

9. The substrate of claim 1, wherein an amount of compression of the spacer disposed at the center is smaller than the amount of compression of the spacer disposed at the edge by about 0.1 μm .

10. The substrate of claim 1, wherein the spacers are formed, such that a condition $1 < A_{\text{center}}/A_{\text{edge}} < 1 + 0.1A_{\text{center}}$ is satisfied, where A_{center} denotes a cross-sectional area of the spacer disposed at the center and A_{edge} denotes a cross-sectional area of the spacer disposed at the edge.

11. The substrate of claim 1, wherein the spacer disposed at the center has a column shape, the spacers being tapered in said direction.

12. The substrate of claim 11, wherein the column is a cylinder, a rectangular prism or a hexagonal prism.

13. The substrate of claim 12, wherein the column is tapered to form truncated cone shape, a frustum of rectangular pyramid shape, a frustum of hexagonal pyramid shape.

14. A liquid crystal display apparatus comprising:

a first substrate including a display region for displaying an image;

a second substrate facing the first substrate;

a fence disposed between the first substrate and the second substrate, the fence surrounding the display region to form a space defined by the first and second substrates and the fence;

a liquid crystal layer disposed in the space; and

a plurality of spacers disposed in the space, the spacers maintaining the distance between the first and second substrates, the spacers having a gradually increasing compression ratio in a direction from a center of the display region to an edge of the display region.

15. The liquid crystal display apparatus of claim 14, wherein the substrate comprises a plurality of pixel electrodes, the spacers being formed such that the spacers deviate from the pixel electrodes.

16. The liquid crystal display apparatus of claim 14, wherein the substrate comprises a black matrix and a common electrode, the spacers being formed such that the spacers are disposed over the black matrix.

17. The liquid crystal display apparatus of claim 14, wherein the spacers are tapered, a side face of the spacer and the transparent substrate forming a tapered angle, the tapered angle of the spacers gradually increasing in the direction, a product of an upper diameter and a lower diameter of the spacers decreasing in the direction.

18. The liquid crystal display apparatus of claim 17, wherein a difference of the tapered angle of the spacer disposed at the edge and the tapered angle of the spacer disposed at the center is no more than about 40°.

19. The liquid crystal display apparatus of claim 14, wherein the spacers are tapered, such that a tapered angle is constant, a side face of the spacer and the transparent substrate forming the tapered angle, a diameter of the spacers decreasing in said direction.

20. The liquid crystal display apparatus of claim 14, wherein a polymer linking density of the spacers decreases in said direction.

21. The liquid crystal display apparatus of claim 14, wherein Young's modulus of the spacers decreases in said direction.

22. The liquid crystal display apparatus of claim 14, wherein an amount of compression of the spacer disposed at the center is smaller than the amount of compression of the spacer disposed at the edge by about 0.1 μm .

23. The liquid crystal display apparatus of claim 14, wherein the spacers are formed, such that a condition $1 < A_{\text{center}}/A_{\text{edge}} < 1 + 0.1A_{\text{center}}$ is satisfied, where A_{center} is a cross-sectional area of the spacer disposed at the center and A_{edge} is a cross-sectional area of the spacer disposed at the edge.

24. The liquid crystal display apparatus of claim 14, wherein the spacer disposed at the center has a column shape, the spacers being tapered in the direction.

25. The liquid crystal display apparatus of claim 24, wherein the column has a cylindrical shape, a rectangular prism shape or a hexagonal prism shape.

26. The liquid crystal display apparatus of claim 25, wherein the column is tapered to form a truncated cone shape, a frustum of rectangular pyramid shape or a frustum of hexagonal pyramid shape.

27. A method of manufacturing a liquid crystal display apparatus comprising:

forming a first substrate including a display region for displaying an image;

forming a second substrate;

forming a plurality of spacers on the display region of the first substrate, the spacers having a gradually increasing compression ratio in a direction from a center of the display region to an edge of the display region;

forming a fence on the first substrate, such that the fence surrounds the display region to form a space defined by the first substrate and the fence;

dropping liquid crystal in the space to fill the space; and

assembling the first and second substrates with each other.

28. The method of claim 27, wherein the spacers are patterned by a photolithography process.

29. The method of claim 28, wherein the photolithography process is executed, such that an amount of light decreasing in said direction.

30. The method of claim 27, wherein the substrate comprises a plurality of pixel electrodes, the spacers being formed such that the spacers deviate from the pixel electrodes.

31. The method of claim 27, wherein the substrate comprises a black matrix and a common electrode, the spacers being formed such that the spacers are disposed over the black matrix.

32. The method of claim 27, wherein the spacers are tapered, a side face of the spacer and the transparent substrate forming a tapered angle, the tapered angle of the spacers gradually increasing in said direction, a product of an upper diameter and a lower diameter of the spacers decreasing in said direction.

33. The method of claim 32, wherein a difference of the tapered angle of the spacer disposed at the edge and the tapered angle of the spacer disposed at the center is no more than about 40°.

34. The method of claim 27, wherein the spacers are tapered, such that a tapered angle is constant, a side face of the spacer and the transparent substrate forming the tapered angle, a diameter of the spacers decreasing in said direction.

35. The method of claim 27, wherein a polymer linking density of the spacers decreases in said direction.

36. The method of claim 27, wherein Young's modulus of the spacers decreases in said direction.

37. The method of claim 27, wherein an amount of compression of the spacer disposed at the center is smaller than the amount of compression of the spacer disposed at the edge by about 0.1 μm .

38. The method of claim 27, wherein the spacers are formed, such that a condition $1 < A_{\text{center}}/A_{\text{edge}} < 1 + 0.1A_{\text{center}}$ is satisfied, where A_{center} denotes a cross-sectional area of the spacer disposed at the center and A_{edge} denotes a cross-sectional area of the spacer disposed at the edge.

39. The method of claim 27, wherein the spacer disposed at the center has a column shape, the spacers being tapered in said direction.

40. The method of claim 39, wherein the column has a cylindrical shape, a rectangular prism shape or a hexagonal prism shape.

41. The method of claim 40, wherein the column is tapered to form truncated cone shape, a frustum of rectangular pyramid shape or a frustum of hexagonal pyramid shape.

42. A method of manufacturing a liquid crystal display apparatus comprising:

forming a first substrate including a display region for displaying an image;

forming a second substrate;

calculating a density and a cross-sectional area of spacers by a comparative liquid crystal display panel;

forming the spacers on the first substrate according to the calculated density and the cross-sectional area;

forming a fence on the first substrate, such that the fence surrounds the display region to form a space defined by the first substrate and the fence;

dropping liquid crystal in the space to fill the space; and

assembling the first and second substrates with each other.

43. The method of claim 42, wherein the substrate comprises a plurality of pixel electrodes, the spacers being formed such that the spacers deviate from the pixel electrodes.

44. The method of claim 42, wherein the substrate comprises a black matrix and a common electrode, the spacers being formed such that the spacers are disposed over the black matrix.

45. The method of claim 42, wherein the density and cross-sectional area of the spacers are calculated via a stiffness factor 'A' expressed by following equation, $A = a \times B \times C$, where 'a' denotes a compensating constant defined by (area of color filter of comparative liquid crystal display panel)/(area of color filter of objective liquid crystal display panel), 'B' denotes the cross-sectional area of the spacer, and 'C' denotes the density of the spacer (or the count of the spacer per color filter).

46. The method of claim 45, wherein an allowable range of the stiffness factor 'A' is determined by:

forming a graph showing a relation between the stiffness factor and a cell gap, and a relation between the stiffness factor and a compression ratio by using the comparative liquid crystal display panel, a size of the comparative liquid crystal display panel being fixed, spacers of the comparative liquid crystal display panel has fixed Young's modulus; and

obtaining the allowable range having a maximum value and a minimum value by the graph.

47. The method of claim 46, wherein the maximum value corresponds to a maximum allowable cell gap, and the minimum value corresponds to a maximum allowable compression ratio.

48. The method of claim 47, wherein the maximum allowable cell gap is obtained by adding a margin to a thickness of the liquid crystal layer.

49. The method of claim 48, wherein the thickness is about 4.65 μm , and the margin is about 0.1 μm .

50. The method of claim 47, wherein the first and the second substrates are damaged when the spacers are compressed above the maximum allowable compression ratio.

51. The method of claim 50, wherein the maximum allowable compression ratio is about 15%.

52. The method of claim of **46**, wherein the comparative liquid crystal display panel corresponds to a 17 inch super extended graphics array (SXGA) liquid crystal display

panel, the allowable range of the stiffness 'A' factor is expressed by

$$(Y_{com}/Y_{ob}) \times 32 \mu m^2 \leq A \leq (Y_{com}/Y_{ob}) \times 76 \mu m^2,$$

where the Y_{com} is Young's modulus of a comparative liquid crystal display panel, Y_{ob} is Young's modulus of an objective liquid crystal display panel.

* * * * *

专利名称(译)	基板，液晶显示装置及其制造方法		
公开(公告)号	US20050099577A1	公开(公告)日	2005-05-12
申请号	US10/643934	申请日	2003-08-20
[标]申请(专利权)人(译)	三星电子株式会社		
申请(专利权)人(译)	SAMSUNG ELECTRONICS CO., LTD.		
当前申请(专利权)人(译)	三星DISPLAY CO., LTD.		
[标]发明人	LEE WOO SHIK YOO GI CHUN JEON BAEK KYUN		
发明人	LEE, WOO-SHIK YOO, GI-CHUN JEON, BAEK-KYUN		
IPC分类号	G02F1/1333 G02F1/1339		
CPC分类号	G02F2001/13396 G02F1/13394		
优先权	1020020049576 2002-08-21 KR 1020020066617 2002-10-30 KR 1020020060498 2002-10-04 KR		
其他公开文献	US7253868		
外部链接	Espacenet USPTO		

摘要(译)

一种液晶显示装置，包括第一和第二基板，栅栏，液晶层和多个间隔物。第一基板包括用于显示图像的显示区域。第二基板面向第一基板。栅栏设置在第一基板和第二基板之间。围栏围绕显示器。间隔物保持第一和第二基板之间的距离。间隔物在从显示区域的中心到显示区域的边缘的方向上具有逐渐增加的压缩比。即使液晶显示装置的中心部分的压缩应力与液晶显示装置的边缘部分的压缩应力不同，液晶显示装置也保持均匀的单元间隙。因此，提高了显示质量。

