



(19) **United States**

(12) **Patent Application Publication** (10) **Pub. No.: US 2003/0147037 A1**

Lee et al.

(43) **Pub. Date:**

Aug. 7, 2003

(54) **APPARATUS AND METHOD FOR MANUFACTURING A LIQUID CRYSTAL DISPLAY DEVICE, A METHOD FOR USING THE APPARATUS, AND A DEVICE PRODUCED BY THE METHOD**

(30) **Foreign Application Priority Data**

Feb. 4, 2002 (KR)..... P2002-6307

Publication Classification

(75) Inventors: **Sang Seok Lee**, Taegu-Kwangyokshi (KR); **Sang Ho Park**, Pusan-Kwangyokshi (KR)

(51) **Int. Cl.⁷** **G02F 1/13**

(52) **U.S. Cl.** **349/187**

Correspondence Address:
MORGAN LEWIS & BOCKIUS LLP
1111 PENNSYLVANIA AVENUE NW
WASHINGTON, DC 20004 (US)

(57) **ABSTRACT**

An apparatus for manufacturing a liquid crystal display device includes a first reverse unit for reversing a first substrate, a bonding unit for bonding the reversed first substrate and a second substrate having a liquid crystal material deposited thereon, and a first loading/unloading unit arranged between the first reverse unit and the bonding unit for loading the first and second substrates into the bonding unit.

(73) Assignee: **LG.Philips LCD Co, Ltd.**

(21) Appl. No.: **10/126,546**

(22) Filed: **Apr. 22, 2002**

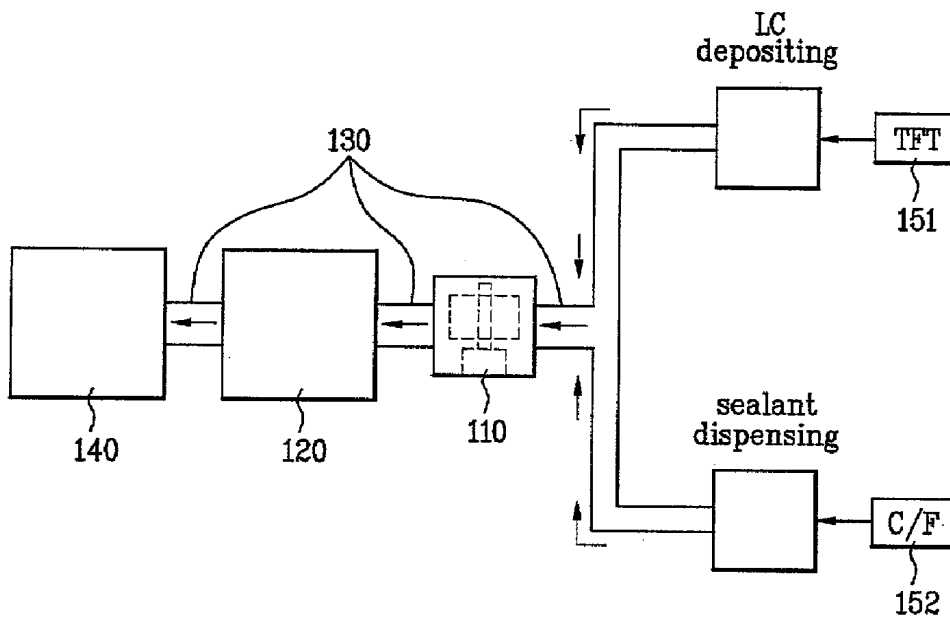

FIG. 1
Related Art

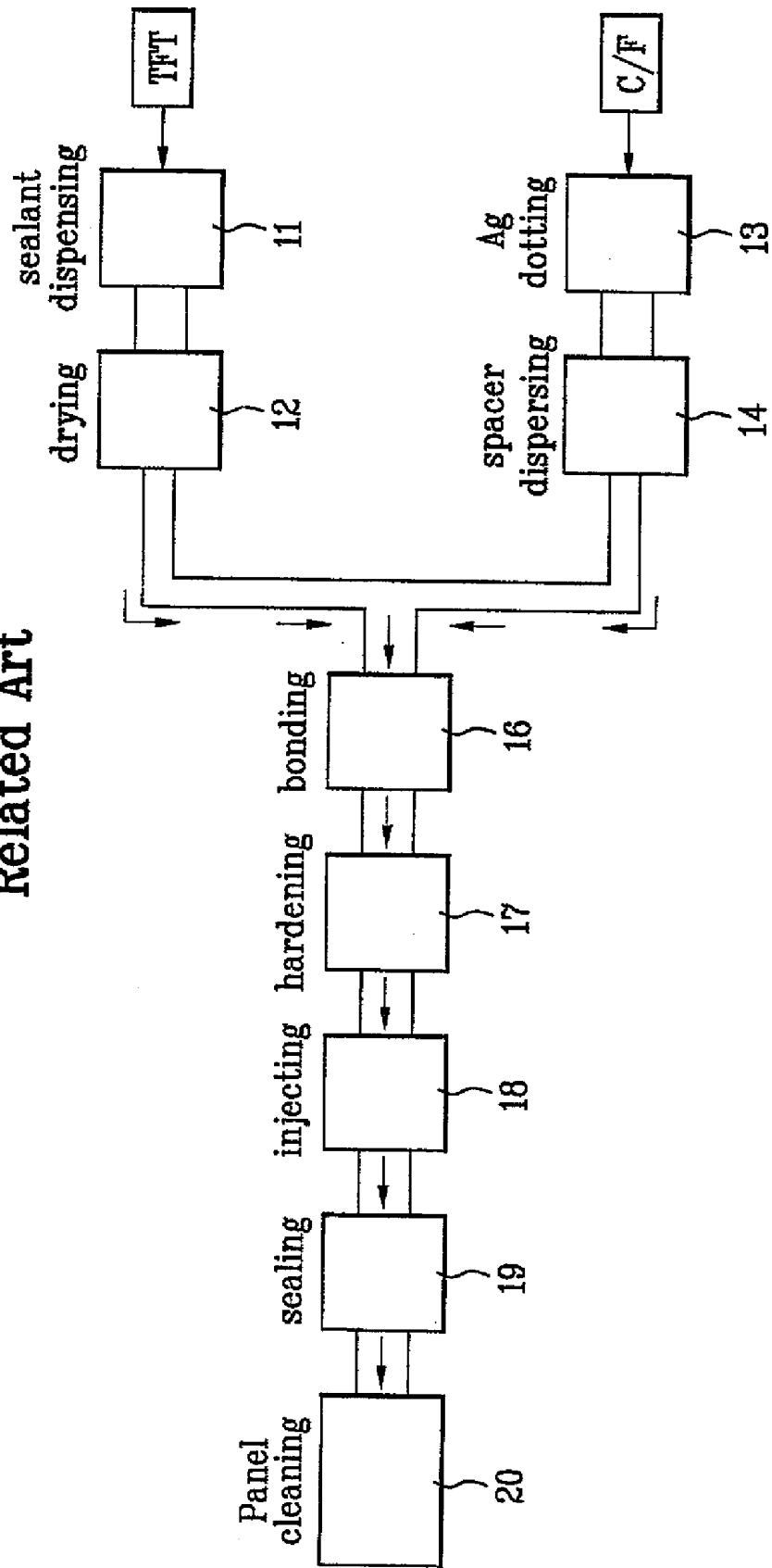

FIG. 2A

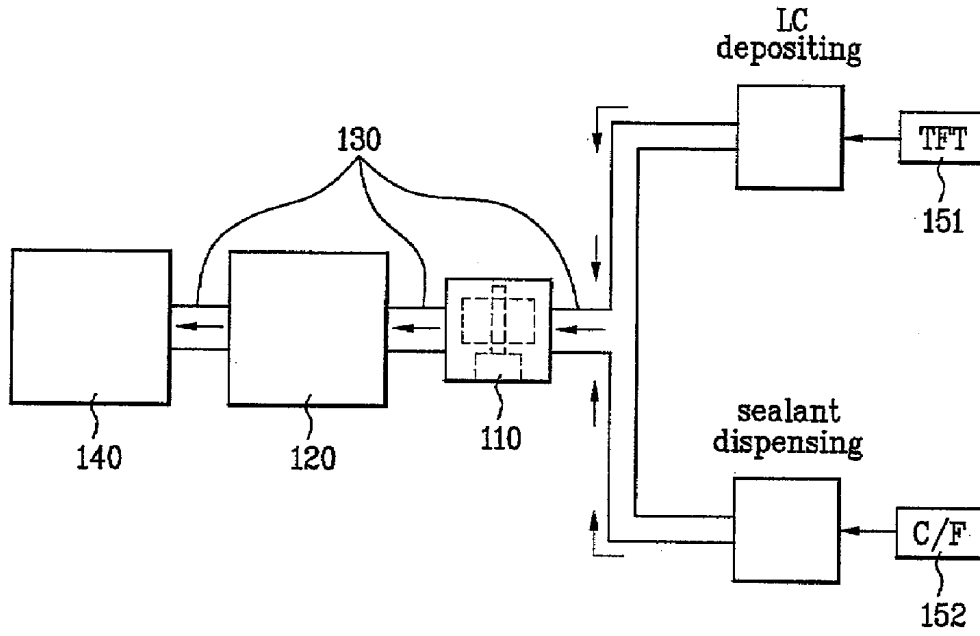

FIG. 2B

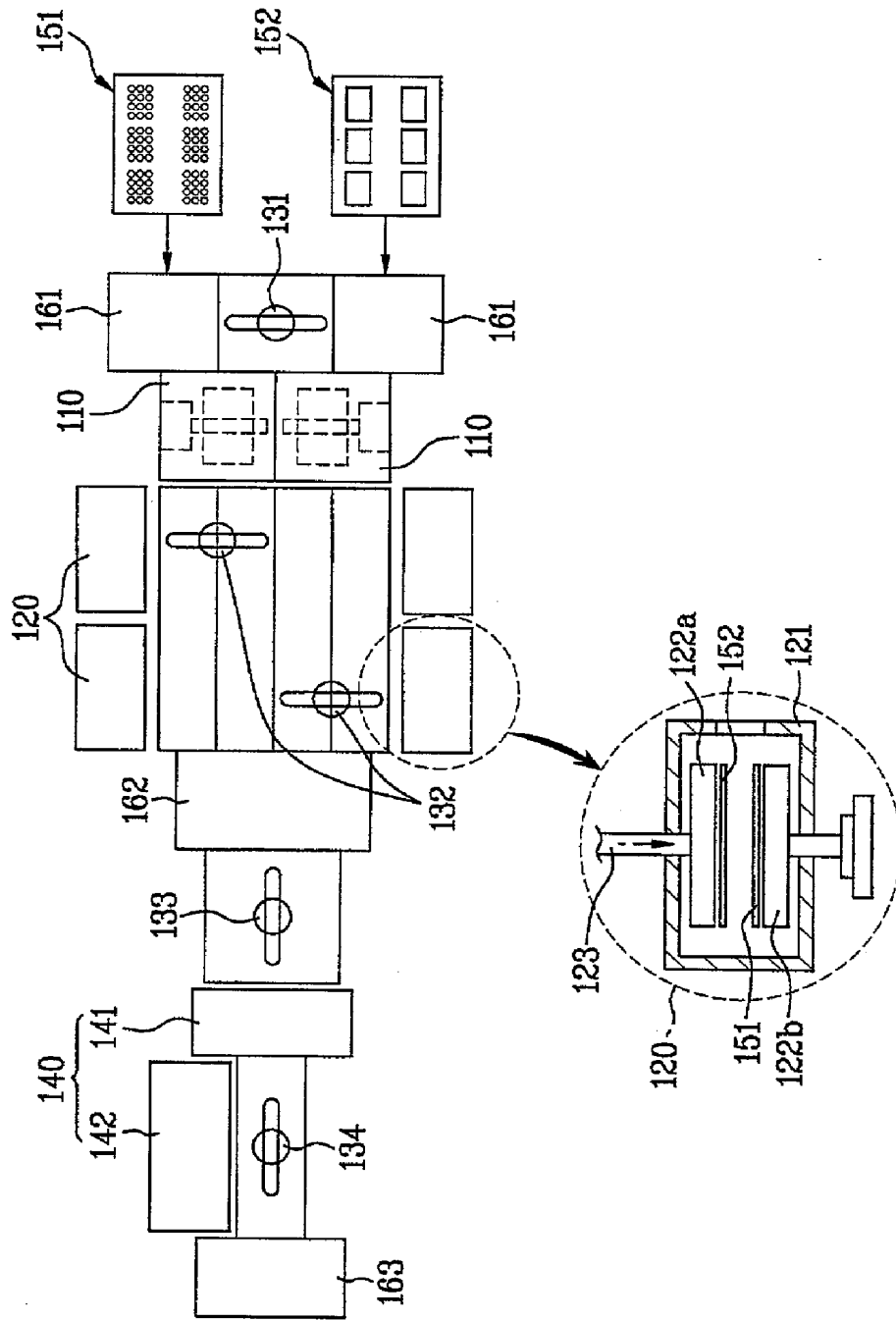

FIG. 3

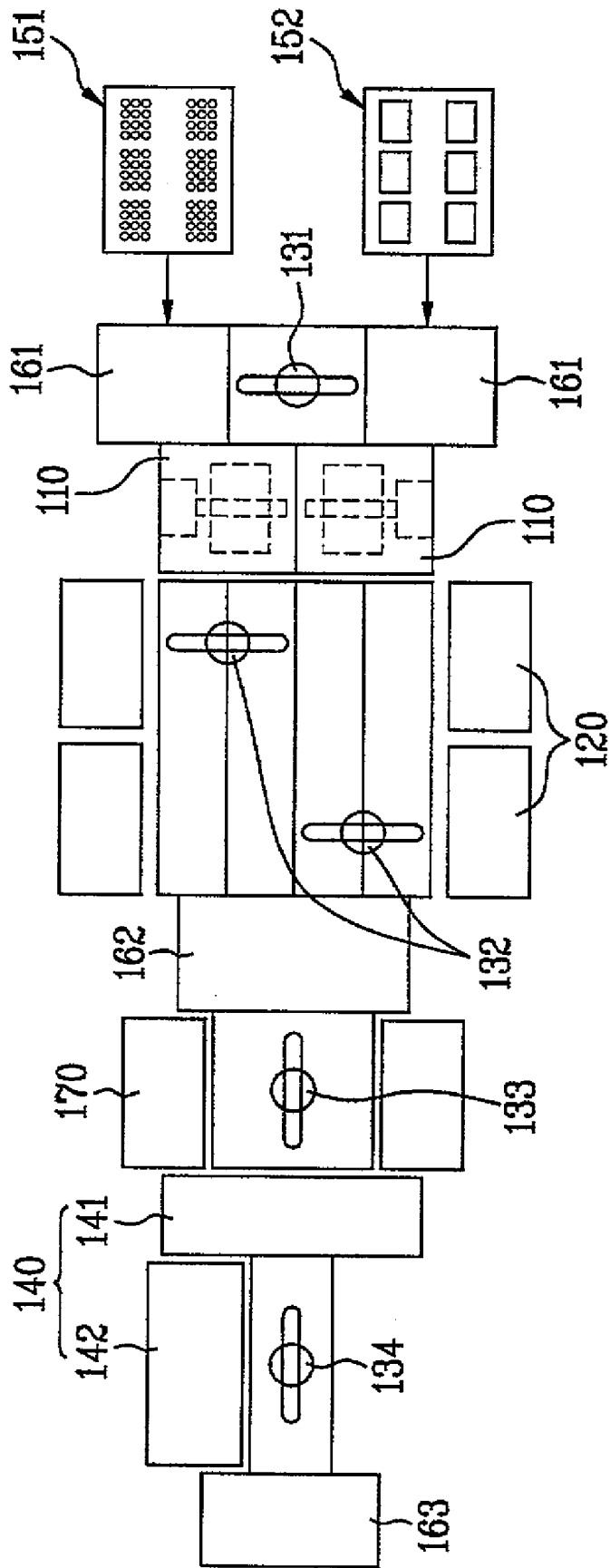

FIG. 4

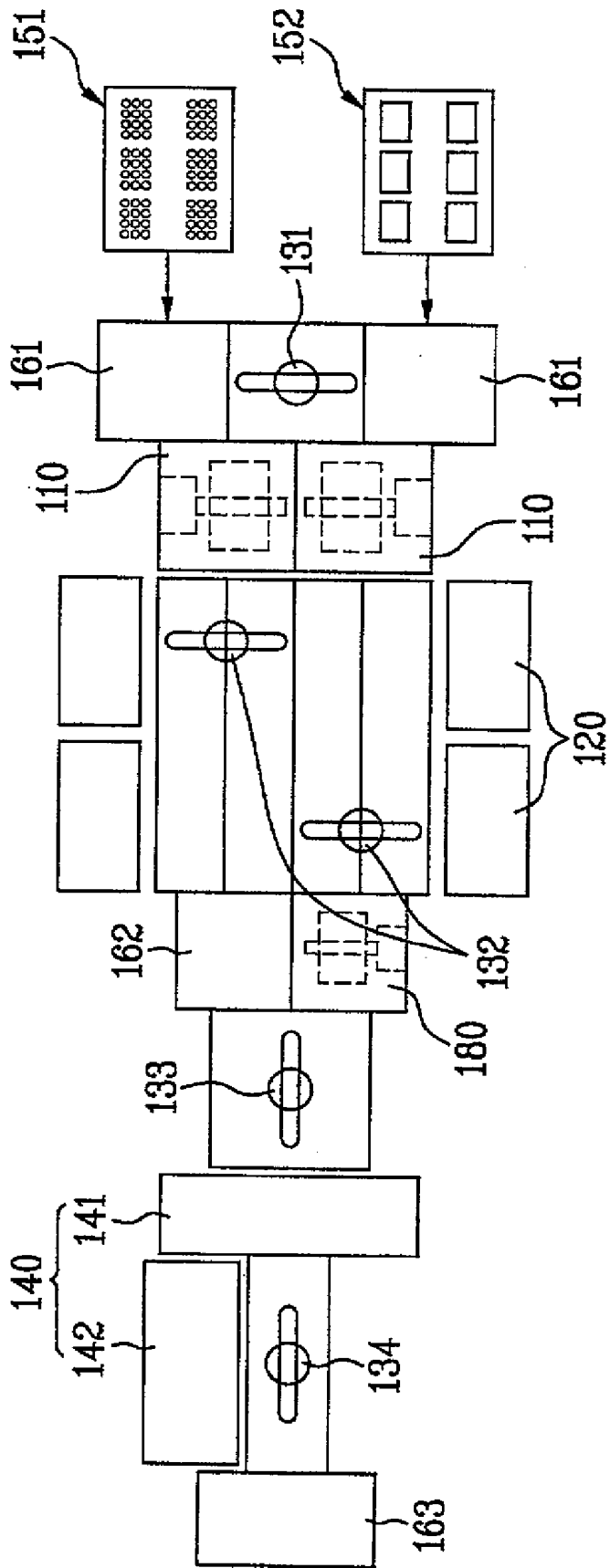

FIG. 5A

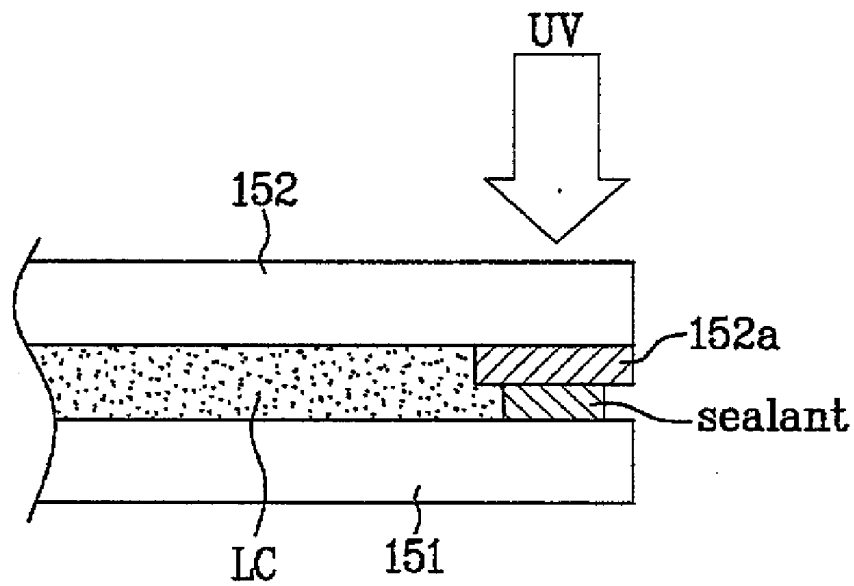

FIG. 5B

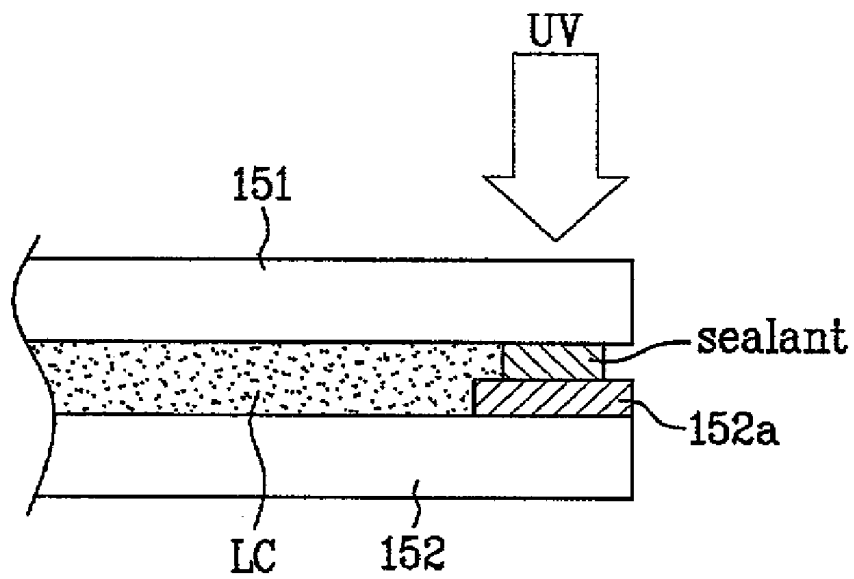
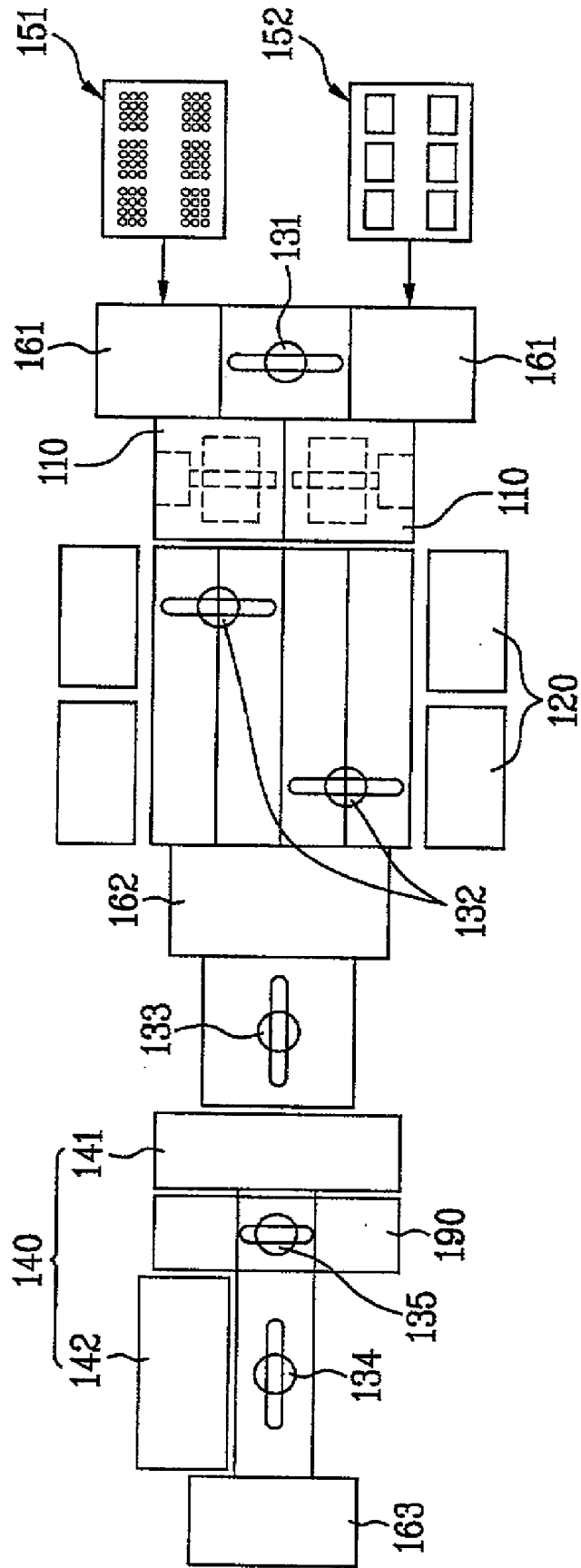

FIG. 6



**APPARATUS AND METHOD FOR
MANUFACTURING A LIQUID CRYSTAL DISPLAY
DEVICE, A METHOD FOR USING THE
APPARATUS, AND A DEVICE PRODUCED BY THE
METHOD**

[0001] The present application claims the benefit of the Korean Patent Application No. P2002-006307 filed in Korea on Feb. 4, 2002, which is hereby incorporated by reference.

BACKGROUND OF THE INVENTION

[0002] 1. Field of the Invention

[0003] The present invention relates to a manufacturing device, and more particularly, to an apparatus and method for manufacturing a liquid crystal display (LCD) suitable for a large-sized liquid crystal display.

[0004] 2. Discussion of the Related Art

[0005] In general, recent developments in the information communication field have increased demand for various types of display devices. In response to this demand, various flat panel type displays such as liquid crystal display (LCD), plasma display panel (PDP), electro-luminescent display (ELD), and vacuum fluorescent display (VFD) have been developed to replace conventional cathode ray tube (CRT) devices. In particular, LCD devices have been used because of their high resolution, light weight, thin profile, and low power consumption. In addition, LCD devices have been implemented in mobile devices such as monitors for notebook computers. Furthermore, LCD devices have been developed for monitors of computer and television to receive and display broadcasting signals.

[0006] Accordingly, efforts to improve image quality of LCD devices contrast with the benefits of their high resolution, light weight, thin profile, and low power consumption. In order to incorporate LCD devices as a general image display, image quality such as fineness, brightness, large-sized area, for example, must be realized.

[0007] LCD devices are provided with an LCD panel for displaying an image, and a driving unit for applying a driving signal to the LCD panel. The LCD panel is provided with first and second glass substrates bonded at a certain distance with liquid crystal material injected therebetween. A plurality of gate lines are formed along one direction at fixed intervals on the first glass substrate (TFT array substrate), and a plurality of data lines are formed along a second direction perpendicular to one direction of the plurality of gate lines, thereby defining a plurality of pixel regions. Then, a plurality of pixel electrodes are formed in a matrix arrangement at the pixel regions, and a plurality of thin film transistors (TFT) are formed at the pixel regions. Accordingly, the plurality of thin film transistors are switched by signals transmitted along the gate lines and transfer signals transmitted along the data lines to each pixel electrode. In order to prevent light leakage, black matrix films are formed on the second glass substrate (color filter substrate) except at regions of the second glass substrate that correspond to the pixel regions of the first glass substrate.

[0008] A process for manufacturing an LCD panel device using a TFT substrate and a color filter substrate will be described with reference to a manufacturing apparatus according to the related art.

[0009] FIG. 1 shows an apparatus for manufacturing an LCD panel device according to the related art. In FIG. 1, a first glass substrate TFT passes through a sealant dispensing unit 11 for dispensing sealant on the first glass substrate TFT, and a sealant drying unit 12 for drying the dispensed sealant. Simultaneously, a second glass substrate C/F passes through an Ag dotting unit 13 for dotting Ag on the second glass substrate C/F, and a spacer dispersion unit 14 for dispersing spacers on the second glass substrate C/F.

[0010] Then, the first and second glass substrates TFT and C/F are bonded together by a bonding unit 16, and the bonded substrates are hardened by a hardening unit 17. The bonded substrates are separated by a certain distance by the spacer, thereby forming a cavity spaced, and an injecting hole is formed at a certain region of a circumference of the bonded substrates. Subsequently, a liquid crystal material is injected by injecting unit 18 through the injecting hole into the cavity space formed between the bonded substrates, and the injecting hole is sealed. Then, the bonded substrates are cleaned by a cleaning unit 20, thereby completing the process of manufacturing the LCD panel device.

[0011] However, the apparatus for manufacturing the LCD panel device according to the related art using the liquid crystal injecting system is problematic. First, the liquid crystal material is injected into the cavity space between the bonded substrates bonded by the sealant through the injecting hole under vacuum due to a difference in pressure. Accordingly, injecting the liquid crystal material into the cavity space is time consuming. During manufacturing processes for making large sized LCD panel devices, it is necessary to improve a manufacturing efficiency of the processes by decreasing the processing time for injecting the liquid crystal material. Accordingly, it is necessary to improve efficiency of the manufacturing processes.

[0012] In addition, failures are generated during the injection of the liquid crystal materials if the processing time for injecting the liquid crystal material is increased. For example, injection of the liquid crystal material may be imperfect, thereby generating failures at a high rate. Second, the processing for manufacturing the LCD panel device is complex, and there is no method for determining whether the bonded substrates are properly bonded together. That is, it is hard to sense a degree with which the substrates are bonded.

SUMMARY OF THE INVENTION

[0013] Accordingly, the present invention is directed to an apparatus for manufacturing a liquid crystal display device, a method for using the apparatus, and a device produced by the apparatus that substantially obviates one or more problems due to limitations and disadvantages of the related art.

[0014] An object of the present invention is to provide an apparatus for manufacturing a liquid crystal display device suitable for a large-sized liquid crystal display.

[0015] Another object of the present invention is to provide a method for using an apparatus for manufacturing a liquid crystal display device suitable for a large-sized liquid crystal display.

[0016] Another object of the present invention is to provide a device produced by a method for manufacturing a liquid crystal display device suitable for a large-sized liquid crystal display.

[0017] Additional features and advantages of the invention will be set forth in the description which follows, and in part will be apparent from the description, or may be learned by practice of the invention. The objectives and other advantages of the invention will be realized and attained by the structure particularly pointed out in the written description and claims hereof as well as the appended drawings.

[0018] To achieve these objects and other advantages and in accordance with the purpose of the invention, as embodied and broadly described herein, an apparatus for manufacturing a liquid crystal display device includes a first reverse unit for reversing a first substrate, a bonding unit for bonding the reversed first substrate and second substrate having a liquid crystal material deposited thereon, and a first loading/unloading unit arranged between the first reverse unit and the bonding unit for loading the first and second substrates into the bonding unit.

[0019] In another aspect, a method for manufacturing a liquid crystal display includes reversing a first substrate, loading the reversed first substrate and a second substrate having a liquid crystal material deposited thereon into a bonding unit, and bonding the first and second substrates.

[0020] In another aspect, a liquid crystal display device manufactured by a method including reversing at least one of a first substrate and a second substrate having a liquid crystal material disposed thereon, loading the first and second substrates into a bonding unit, and bonding the first and second substrates.

[0021] It is to be understood that both the foregoing general description and the following detailed description are exemplary and explanatory and are intended to provide further explanation of the invention as claimed.

BRIEF DESCRIPTION OF THE DRAWINGS

[0022] The accompanying drawings, which are included to provide a further understanding of the invention and are incorporated in and constitute a part of this specification, illustrate embodiments of the invention and together with the description serve to explain the principle of the invention. In the drawings:

[0023] **FIG. 1** shows an apparatus for manufacturing an LCD device according to the related art;

[0024] **FIGS. 2A and 2B** show an exemplary apparatus for manufacturing an LCD device according to the present invention;

[0025] **FIG. 3** shows another exemplary apparatus for manufacturing an LCD device according to the present invention;

[0026] **FIG. 4** shows another exemplary apparatus for manufacturing an LCD device according to the present invention;

[0027] **FIGS. 5A and 5B** show cross sectional views of main portions an exemplary LCD device illustrating photo-hardening degree states of the sealant according to relative positions of the bonded substrates during a photo-curing process according to the present invention; and

[0028] **FIG. 6** shows another exemplary apparatus for manufacturing an LCD device according to the present invention.

DETAILED DESCRIPTION OF THE PREFERRED EMBODIMENTS

[0029] Reference will now be made in detail to the preferred embodiments of the present invention, examples of which are illustrated in the accompanying drawings.

[0030] **FIGS. 2A and 2B** show an exemplary apparatus for manufacturing an LCD device according to the present invention. In **FIGS. 2A and 2B**, the apparatus may include a first reverse unit **110**, at least one bonding unit **120** disposed within a vacuum processing chamber **121**, and a plurality of loading/unloading units **130**. In addition, the apparatus may be provided with a hardening unit **140**.

[0031] A liquid crystal material may be deposited (i.e., drop dispensed) onto a first substrate **151**, and a sealant (not shown) may be deposited onto a second substrate **152**. Then, the first reverse unit **110** may reverse (i.e., flip) the second substrate **152** upon which the sealant is dispensed. The first reverse unit **110** may not necessarily reverse each of the first and second substrates **151** and **152**, and may reverse only one of the first and second substrates **151** and **152** upon which the liquid crystal material is not deposited. Moreover, the first and second substrate **151** and **152** may be one of either a TFT array substrate or a color filter (C/F) substrate. Alternatively, the first reverse unit may reverse the substrate having the liquid crystal material deposited thereupon provided that the viscosity of the liquid crystal material is large enough so as to prevent any flow of the liquid crystal material during the reversing process.

[0032] The first reverse unit **110** may have various configurations based upon the assumption that only one the first and second substrates **151** and **152** may be reversed. For example, although not shown, the liquid crystal material may be deposited on the first substrate **151**, which may be a C/F substrate, and the sealant may be deposited on the second substrate **152**, which may be a TFT array substrate. Moreover, both the liquid crystal material and the sealant may be deposited on the first substrate **151**, which may be a TFT array substrate, and the second substrate **152**, which may be a C/F substrate, may not have either of the liquid crystal material or the sealant deposited thereon. Furthermore, both the liquid crystal material and the sealant may be deposited on the first substrate **151**, which may be a C/F substrate, and the second substrate **152**, which may be a TFT array substrate, may not have either of the liquid crystal material or the sealant deposited thereon.

[0033] The bonding unit **120** may be provided within the vacuum processing chamber **121**, and may include an upper stage **122a**, a lower stage **122b**, and a moving means **123** for selectively moving either one or both of the upper and lower stages **122a** and **122b**. Accordingly, the upper stage **122a** may be provided at an upper side of the vacuum processing chamber **121** to hold the second substrate **152** and, the lower stage **122b** may be provided at a lower side of the vacuum processing chamber **121** to hold the first substrate **151**. The bonding unit **120** may bond the first and second substrates **151** and **152** to produce bonded substrates.

[0034] The hardening unit **140** may include a photo-curing photo-hardening unit **141**, which may subject the bonded substrates to an emitted light such as UV, for example, and thermal hardening unit **142**, which may heat the bonded substrates. Accordingly, the hardening unit **140** may include

the photo-curing unit **141** and the thermal hardening unit **142** as a single processing unit. Alternatively, the hardening unit **140** may include the photo-curing unit **141** and the thermal hardening unit **142** as multiple processing units. If the hardening unit **140** is provided with both the photo-curing unit **141** and the thermal hardening unit **142**, the photo-curing unit **141** receives the bonded substrates and cures the bonded substrates by the emitted light. Then, the thermal hardening unit **142** may receive the photo-cured, bonded substrates, and harden the sealant by processing under high temperature conditions. In addition, the thermal hardening unit **142** may permit the liquid crystal material to flow between the bonded substrates, thereby dispersing the liquid crystal material uniformly between the bonded substrates.

[0035] The loading/unloading units **130** may be provided between the first reverse unit **110**, the bonding unit **120**, and the hardening unit **140**. The loading/unloading units **130** may include a first loading/unloading unit **131**, a plurality of second loading/unloading units **132**, a third loading/unloading unit **133**, and a fourth loading/unloading unit **134**. Each of the loading/unloading units **130** may include mechanical devices such as a robot-arm, for example, to obtain relatively high precision and accuracy in moving the substrates. Alternatively, the loading/unloading units **130** may include various types of devices for providing relatively high precision and accuracy and may combine various different types of devices such as conveyors and robot arms.

[0036] A processing time of each processing step may vary according to each individual processing modules (i.e., units). For example, a processing time for the plurality of bonding units **120** may be different than a processing time for the hardening unit **140**. Accordingly, buffer units may be provided between any of the reverse, bonding, and hardening units to provisionally store any of the first and second substrates **151** and **152**, as well as the bonded substrates prior to subsequent processing steps. The buffer units may have at least one substrate cassette in which a plurality of bonded substrates may be provisionally stored at multiple levels.

[0037] In FIG. 2B, a first buffer unit **161** may be provided at a first side, or sides of the first loading/unloading unit **131** for loading the first and second substrates **151** and **152** to the first reverse unit **110**. A second buffer unit **162** may be provided at a side of the plurality of second loading/unloading units **132** for unloading the bonded substrates from the bonding unit **120** and at a side of the third loading/unloading unit **133** for loading the bonded substrates into the hardening unit **140**. A third buffer unit **163** may be provided at a side of the fourth loading/unloading unit **134** for unloading the bonded substrates from the hardening unit **140**. Each of the first, second, and third buffer units **161**, **162** and **163** may be provided with a pair of substrate cassettes for temporarily storing each of the first and second substrates **151** and **152** in the first buffer unit **161**, the bonded substrates in the second buffer unit **162**, and the bonded substrates in the third buffer unit **163** after being processed in the hardening unit **140**.

[0038] In FIG. 2B, a plurality of the bonding units **120** may be disposed to face each other, and the plurality of second loading/unloading units **132** may be provided between the first reverse unit **110** and each of the plurality

of bonding units **120**. Accordingly, the plurality of second loading/unloading units **132** may selectively load the first and second substrates **151** and **152** from the first reverse unit **110** into the plurality of bonding units **120**, and simultaneously transfer the bonded substrates to the second buffer unit **162**. In addition, the first reverse unit **110**, the second buffer unit **162**, and the second loading/unloading unit **131** may be arranged along a first line, and the plurality of bonding units **120** may be arranged along a second line that is perpendicular to the first line. The third loading/unloading unit **133** may be provided between the second buffer unit **162** and the photo-curing unit **141**. The third loading/unloading unit **133** may load the bonded substrates into the photo-curing unit **141** from the second buffer unit **162**. In addition, a fourth loading/unloading unit **134** may be provided between the photo-curing unit **141** and the thermal hardening unit **142**. The fourth loading/unloading unit **134** may load the bonded substrate into the thermal hardening unit **142** from the photo-curing unit **141**.

[0039] Operation of the exemplary apparatus for manufacturing a LCD device according to the present invention will be described with regard to FIGS. 2A and 2B. During a first transfer process, the first loading/unloading unit **131** may selectively transfer the first and second substrates **151** and **152** to the first reverse unit **110** from the first buffer unit **161**. The first substrate **151** and the second substrate **152** may have undergone a plurality of processing steps prior to being placed into the first buffer unit **161**. For example, the first and second substrates **151** and **152** may have undergone cleaning, liquid crystal material deposition, and sealant deposition processes prior to loading the first and second substrates **151** and **152** into the first buffer unit **161**. In addition, the first and second substrates **151** and **152** may have undergone inspection processes prior to, or between the different clean, liquid crystal deposition, and sealant deposition processing. As previously described above, the first and second substrates **151** and **152** may have one of many different combinations of the liquid crystal material and/or sealant deposited thereupon. In addition, the first and second substrates **151** and **152** may alternatively include one of a C/F substrate and a TFT array substrate.

[0040] After the first transfer process, a first loading process may include individually loading the first and second substrates **151** and **152** into the first reverse unit **110** from the first buffer unit **161** by the first loading/unloading unit **131**. Alternatively, the first loading process may include simultaneously loading the first and second substrates **151** and **152** into the first reverse unit **110** from the first buffer unit **161** by the first loading/unloading unit **131**.

[0041] After the first loading process, a sensing process may include sensing by the first reverse unit **110** as to whether the first substrate **151** or the second substrates **152** has the liquid crystal material. During the sensing process, the first reverse unit **110** may sense each of the first and second substrates **151** and **152** by reading a specific indicia (not shown) that is assigned to each of the first and second substrates **151** and **152**. For example, a distinctive mark or code may be disposed in an inactive region of each of the first and second substrates **151** and **152**. Accordingly, the first reverse unit **110** may include a mark or code reader (not shown) that reads the mark or code of each of the first and second substrates **151** and **152** and senses whether the mark

or code indicates that the first and second substrates **151** and **152** does or does not have the liquid crystal material.

[0042] After the sensing process, a reversing process may be performed in which the one of the first and second substrates **151** and **152** not having the liquid crystal material may be reversed (flipped).

[0043] After the reversing process, a second loading process may include individually loading the first and second substrates **151** and **152** into one of the plurality of bonding units **120** from the first reversing unit **110** by a plurality of the second loading/unloading units **132**. Alternatively, the second loading process may include simultaneously loading the first and second substrates **151** and **152** into the plurality of bonding units **120** from the first reversing unit **110** by the plurality of second loading/unloading units **132**.

[0044] During the second loading process, the substrate that includes the liquid crystal material (now referenced as the first substrate **151**), may be loaded onto a lower stage **122b** of the vacuum processing chamber **121** by a first of the plurality of second loading/unloading units **132**. In addition, the substrate that does not include the liquid crystal material (now referenced as the second substrate **152**), may be loaded onto an upper stage **122a** of the vacuum processing chamber **121** by the first of the plurality of second loading/unloading units **132**. Alternatively, the second substrate **152** may be loaded onto the upper stage **122a** by a second of the plurality of second loading/unloading units **132**.

[0045] After the second loading process, a bonding process may include a moving means **123** of the bonding unit **120** that may move at least one of the upper and lower stages **122a** and **122b** to press and bond the first and second substrates **151** and **152**, thereby forming bonded substrates.

[0046] After the bonding process, a third loading process may include individually loading the bonded substrates into the second buffer unit **162** from each of the plurality of bonding units **120** by the plurality of second loading/unloading units **132**. Alternatively, the third loading process may include simultaneously loading the bonded substrates into the second buffer unit **162** from the plurality of bonding units **140** by the plurality of second loading/unloading units **132**.

[0047] After the third loading process, a fourth loading process may include individually loading the bonded substrates into the photo-curing unit **141** of the hardening unit **140** from the second buffer unit **162** by the third loading/unloading unit **133**.

[0048] After the fourth loading process, a photo-curing process may include exposing the sealant disposed between the bonded substrates to light such as ultraviolet (UV) light, for example, thereby curing the sealant. The photo-curing unit **141** may include a mask such that a TFT array region of the TFT array substrate **151** is shielded from the light.

[0049] After the photo-curing process, a fifth loading process may include individually loading the bonded substrates into the thermal hardening unit **142** from the photo-curing unit **141** by the fourth loading/unloading unit **134**. The thermal hardening unit **142** may expose the bonded substrates to elevated temperatures, thereby raising a temperature of the liquid crystal material. Accordingly, the

liquid crystal material may flow to evenly disperse between the bonded substrates, and the sealant may harden.

[0050] After the fifth loading process, a sixth loading process may include individually loading the bonded substrates into a third buffer unit **163** from the thermal hardening unit **142** by the fourth loading/unloading unit **134**. Then, the bonded substrates may be transferred for further processing.

[0051] FIG. 3 shows another exemplary apparatus for manufacturing an LCD device according to the present invention. The exemplary apparatus shown in FIG. 3 may include the features shown in FIGS. 2A and 2B, and may include a plurality of supplemental pressing units **170** arranged between the plurality of bonding units **120** and the hardening unit **140**. The supplemental pressing units **170** may additionally apply pressure to the bonded substrates to improve a bonding state between the bonded substrates. In addition, each of the plurality of supplemental pressing units may be arranged at opposing sides of the third loading/unloading unit **133**. The third loading/unloading unit **133** may individually load the bonded substrates into one of the supplemental pressing units **170** from the second buffer unit **162**. In addition, the third loading/unloading unit **133** may also individually load the bonded substrates into the photo-curing unit **141** of the hardening unit **140** from the supplemental pressing units **170**. Accordingly, an additional loading process may include individually loading the bonded substrates into the photo-curing unit **141** from the supplemental pressing units **170** without the need for an additional loading/unloading unit.

[0052] In FIG. 3, the second buffer unit **162** and the supplemental pressing units **170** may not be formed along a single line. Accordingly, the third loading/unloading unit **133** may be provided along another line with the second buffer unit **162** and the photo-hardening unit **141**, and the supplemental pressing units **170** may be provided along a line perpendicular to the third loading/unloading unit **133**. Accordingly, the first and second substrates **151** and **152** may first be bonded by the bonding unit **120**, and then additionally pressed by the supplemental pressing unit **170**. Then, the third loading/unloading unit **133** may transfer the bonded substrates additionally pressed by the supplemental pressing units **170** to the second buffer unit **162**.

[0053] FIG. 4 shows another exemplary apparatus for manufacturing an LCD device according to the present invention. The exemplary apparatus shown in FIG. 4 may include the features shown in FIGS. 2A and 2B, and may include a second reverse unit **180** arranged between the plurality of bonding units **120** and the hardening unit **140**. The second reverse unit **180** may selectively reverse the bonded substrates bonded by the plurality of bonding units **120**.

[0054] FIGS. 5A and 5B show cross sectional views of main portions an exemplary LCD device illustrating photo-hardening degree states of the sealant according to relative positions of the bonded substrates during a photo-curing process according to the present invention. In FIGS. 5A and 5B, black matrix films **152a** may be formed on the second substrate **152** (C/F substrate) except for regions corresponding to pixel regions of the first substrate **151** (TFT array substrate). The black matrix films **152** prevent the light

emitted during the photo-curing unit **141** from reaching the sealant. Accordingly, the sealant may not be sufficiently hardened.

[0055] The second reverse unit **180** may include a sensing unit that may sense whether the black matrix films **152a** are formed on the C/F substrate **152** or on the TFT array substrate **151**. In cases where the black matrix films **152a** are formed on the C/F substrate **152**, the bonded substrates are reversed by the second reverse unit **180** shown in **FIG. 4**.

[0056] Accordingly, the sealant will be exposed to the light in the photo-curing unit **141**, thereby sufficiently hardening the sealant. The sensing unit may read a specific indicia (not shown) that is assigned to each of the bonded substrates. For example, a distinctive mark or code may be disposed in an inactive region of each of the bonded substrates. The second reverse unit **180** may include a mark or code reader (not shown) that reads the mark or code of each of the bonded substrates, and senses whether the mark or code indicates that the upper bonded substrate is a C/F substrate or a TFT array substrate. Accordingly, during the operation of the apparatus shown in **FIG. 4**, a second reverse process may be necessary after the third loading process. During the second reverse process, the bonded substrates that are sensed to have a C/F substrate as the uppermost substrate may be individually loaded into the second reverse unit **180** from the plurality of bonding units **120** by the second loading/unloading units **132**. Then, the second reverse unit **180** reverses an orientation of the bonded substrates such that the TFT array substrate is now the uppermost substrate. The reversed bonded substrate is loaded to the second buffer unit **162** from the second reverse unit **180** by one of the second loading/unloading units **132**, or by the third loading/unloading unit **133**. Alternatively, an additional loading/unloading unit may be incorporated, whereby neither of the second loading/unloading units **132** nor the third loading/unloading unit **133** need to be used.

[0057] **FIG. 6** shows another exemplary apparatus for manufacturing an LCD device according to the present invention. The exemplary apparatus shown in **FIG. 6** may include the features shown in **FIGS. 2A and 2B**, and may include bonding degree sensing units **190** for sensing a degree of bonding between the bonded substrate provided between the photo-curing unit **141** and the thermal hardening unit **142**, and a fifth loading/unloading unit **135** provided between the bonding degree sensing units **190**, the photo-curing unit **141**, and the fourth loading/unloading unit **134**. The fifth loading/unloading unit **135** may load the bonded substrates into the bonding degree sensing units **190** from the photo-curing unit **141**, and may load the bonded substrates into the thermal-hardening unit **142** if the bonding degree of the bonded substrates are determined to be sufficient by the bonding degree sensing units **190**. Alternatively, the fifth loading/unloading unit **135** may be omitted, and the fourth loading/unloading unit **134** may load the bonded substrates between the photo-curing unit **141**, the bonding degree sensing units **190**, and the thermal-hardening unit **142**. Moreover, it may not be necessary to provide the bonding degree sensing unit **190** between the photo-hardening unit **141** and the thermal hardening unit **142**.

[0058] Alternatively, the bonding degree sensing units **190** may be provided at a processing region after the plurality of bonding units **120** and before the hardening unit **140**,

thereby removing bonded substrates with insufficient bond degree and preventing unnecessary processing time of the bonded substrates.

[0059] It will be apparent to those skilled in the art than various modifications and variations can be made in the apparatus and method for manufacturing a liquid crystal display device of the present invention without departing from the spirit or scope of the invention. Thus, it is intended that the present invention cover the modifications and variations of this invention provided they come within the scope of the appended claims and their equivalents.

What is claimed is:

1. An apparatus for manufacturing a liquid crystal display device, comprising:

a first reverse unit for reversing a first substrate;

a bonding unit for bonding the reversed first substrate and a second substrate having a liquid crystal material deposited thereon; and

a first loading/unloading unit arranged between the first reverse unit and the bonding unit for loading the first and second substrates into the bonding unit.

2. The apparatus according to claim 1, wherein one of the first and second substrates includes a color filter substrate, and an other one of the first and second substrates includes a TFT array substrate.

3. The apparatus according to claim 1, further comprising a hardening unit provided after the bonding unit for hardening the bonded substrates.

4. The apparatus according to claim 3, wherein the hardening unit is provided with a photo-curing unit for hardening the bonded substrates.

5. The apparatus according to claim 4, wherein the photo-curing unit emits UV light.

6. The apparatus according to claim 3, further comprising a second reverse unit arranged between the bonding unit and the hardening unit to selectively reverse a surface of the bonded substrates.

7. The apparatus according to claim 3, wherein the hardening unit includes a thermal-hardening unit for hardening the bonded substrates.

8. The apparatus according to claim 3, wherein the hardening unit includes a photo-curing unit and a thermal-hardening unit for hardening the bonded substrates.

9. The apparatus according to claim 8, wherein the photo-curing unit emits UTV light.

10. The apparatus according to claim 8, further comprising a second reverse unit arranged between the bonding unit and the hardening unit to selectively reverse a surface of the bonded substrates.

11. The apparatus according to claim 8, further comprising a bonding degree sensing unit arranged between the photo-curing unit and the thermal-hardening unit to sense a degree of the bonded substrates.

12. The apparatus according to claim 8, further comprising a second loading/unloading unit arranged between the photo-curing unit and the thermal-hardening unit to transfer the bonded substrates to the thermal-hardening unit.

13. The apparatus according to claim 3, further comprising a bonding degree sensing unit arranged next to the bonding unit to sense a degree of bonding of the bonded substrates.

14. The apparatus according to claim 3, further comprising a first buffer unit arranged between the bonding unit and the hardening unit to store the bonded substrates before transferring the bonded substrates to the hardening unit.

15. The apparatus according to claim 14, wherein the first reverse unit, the first buffer unit, and the first loading/unloading unit are arranged along a first line, and the bonding unit is arranged along a second line perpendicular to the first line, so that the first loading/unloading unit transfers the bonded substrates to the first buffer unit.

16. The apparatus according to claim 14, further comprising a third loading unit arranged between the first buffer unit and the hardening unit to transfer the bonded substrates stored in the first buffer unit to the hardening unit.

17. The apparatus according to claim 3, further comprising a second buffer unit for storing the bonded substrates hardened by the hardening unit.

18. The apparatus according to claim 1, further comprising a supplemental pressing unit arranged next to the bonding unit to press the bonded substrates.

19. The apparatus according to claim 1, further comprising a third buffer unit arranged next to the first reverse unit for storing the first and second substrates.

20. The apparatus according to claim 19, further comprising an additional fourth loading/unloading unit arranged between the third buffer unit and the first reverse unit to selectively transfer the first and second substrates stored in the third buffer unit to the first reverse unit.

21. A method for manufacturing an LCD, comprising the steps of:

reversing a first substrate;

loading the first reversed substrate and a second substrate having a liquid crystal material deposited thereon into a bonding unit; and

bonding the first and second substrates.

22. The method according to claim 21, wherein one of the first and second substrates includes a color filter substrate, and another one of the first and second substrates includes a TFT array substrate.

23. The method according to claim 21, further comprising a step of hardening the bonded substrates.

24. The method according to claim 23, wherein the step of hardening includes photo-curing.

25. The method according to claim 24, wherein the photo-curing includes emission of UV light.

26. The method according to claim 23, further comprising a step of selectively reverse a surface of the bonded substrates before the step of hardening.

27. The method according to claim 23, wherein the step of hardening includes thermal-hardening of the bonded substrates.

28. The method according to claim 23, wherein the step of hardening includes steps of photo-curing and thermal-hardening of the bonded substrates.

29. The method according to claim 28, wherein the step of photo-curing includes emission of UV light.

30. The method according to claim 28, further comprising a step of selectively reversing a surface of the bonded substrates before the step of hardening.

31. The method according to claim 28, further comprising a step of sensing a bonding degree of the bonded substrates.

32. The method according to claim 28, further comprising a step of transferring the bonded substrates after the step of photo-curing and before the step of thermal-hardening the bonded substrates.

33. The method according to claim 23, further comprising a step of storing the bonded substrates before the step of hardening the bonded substrates.

34. The method according to claim 33, further comprising a step of transferring the bonded substrates before the step of hardening the bonded substrates and after the step of storing the bonded substrates.

35. The method according to claim 23, further comprising a step of sensing a bonding degree of the bonded substrates during the step of hardening the bonded substrates.

36. The method according to claim 23, further comprising a step of storing the bonded substrates after the step of hardening the bonded substrates.

37. The method according to claim 21, further comprising a step of supplemental pressing the bonded substrates after the step of bonding the first and second substrates.

38. The method according to claim 21, further comprising a step of storing the first and second substrates before the step of reversing the first substrate.

39. The method according to claim 38, further comprising a step of transferring the first and second substrates after the step of storing the first and second substrates.

40. A liquid crystal display device manufactured by a method, comprising the steps of:

reversing a first substrate;

loading the first reversed substrate and a second substrate having a liquid crystal material deposited thereon into a bonding unit; and

bonding the first and second substrates.

41. The liquid crystal display device according to claim 40, wherein one of the first and second substrates includes a color filter substrate, and another one of the first and second substrates includes a TFT array substrate.

* * * * *

专利名称(译)	用于制造液晶显示装置的装置和方法，使用该装置的方法以及由该方法制造的装置		
公开(公告)号	US20030147037A1	公开(公告)日	2003-08-07
申请号	US10/126546	申请日	2002-04-22
[标]申请(专利权)人(译)	乐金显示有限公司		
申请(专利权)人(译)	LG.PHILIPS LCD CO. , LTD.		
当前申请(专利权)人(译)	LG DISPLAY CO. , LTD.		
[标]发明人	LEE SANG SEOK PARK SANG HO		
发明人	LEE, SANG SEOK PARK, SANG HO		
IPC分类号	G02F1/13 G02F1/1339 G02F1/1341		
CPC分类号	G02F1/1339 G02F2001/13415 G02F1/1341		
优先权	1020020006307 2002-02-04 KR		
其他公开文献	US6859250		
外部链接	Espacenet USPTO		

摘要(译)

一种用于制造液晶显示装置的设备，包括：第一反转单元，用于反转第一基板；结合单元，用于结合反转的第一基板；以及第二基板，具有沉积在其上的液晶材料；以及第一装载/卸载单元，设置在第一基板和第二基板之间。第一反转单元和粘合单元，用于将第一和第二基板装载到粘合单元中。

