



(19) **United States**

(12) **Patent Application Publication**

(10) **Pub. No.: US 2002/0054267 A1**

Matsumoto et al.

(43) **Pub. Date:**

May 9, 2002

(54) **LIQUID CRYSTAL DISPLAY DEVICE AND METHOD FOR MANUFACTURING SAME AND COLOR FILTER SUBSTRATE**

Publication Classification

(51) **Int. Cl.⁷** G02F 1/1339
(52) **U.S. Cl.** 349/155

(76) **Inventors:** **Kimikazu Matsumoto**, Tokyo (JP);
Makoto Watanabe, Tokyo (JP)

(57) **ABSTRACT**

A liquid crystal display device is provided which is capable of canceling out effects of signal charges, even when a columnar spacer bears the signal charges, and preventing disturbance in a traverse electric field.

In the above liquid crystal display device, a columnar area ratio being a ratio of a cross sectional area of a columnar spacer to an area of each of unit pixels including a unit pixel for a red (R) color, a unit pixel for a green (G) color, and a unit pixel for a blue (B) color is set within a range of 0.05% to 0.15%; and each columnar spacer making up a pair of columnar spacers is disposed in each of two unit pixels being arranged in a matrix form and being adjacent to each other in a row or column direction at an arbitrary place in a plurality of places where unit pixels are arranged.

Correspondence Address:
McGinn & Gibb, PLLC
Suite 200
8321 Old Courthouse Road
Vienna, VA 22182-3817 (US)

(21) **Appl. No.:** **09/986,109**

(22) **Filed:** **Nov. 7, 2001**

(30) **Foreign Application Priority Data**

Nov. 9, 2000 (JP) 2000-342163

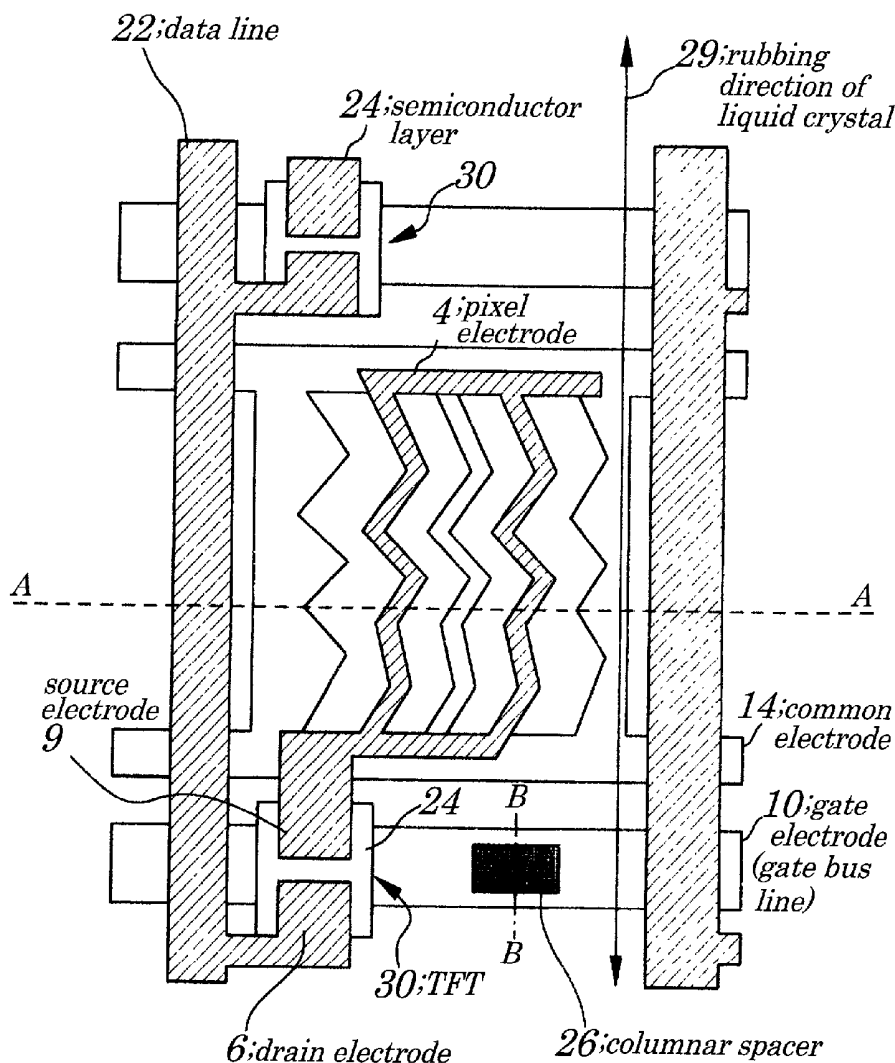

FIG. 1

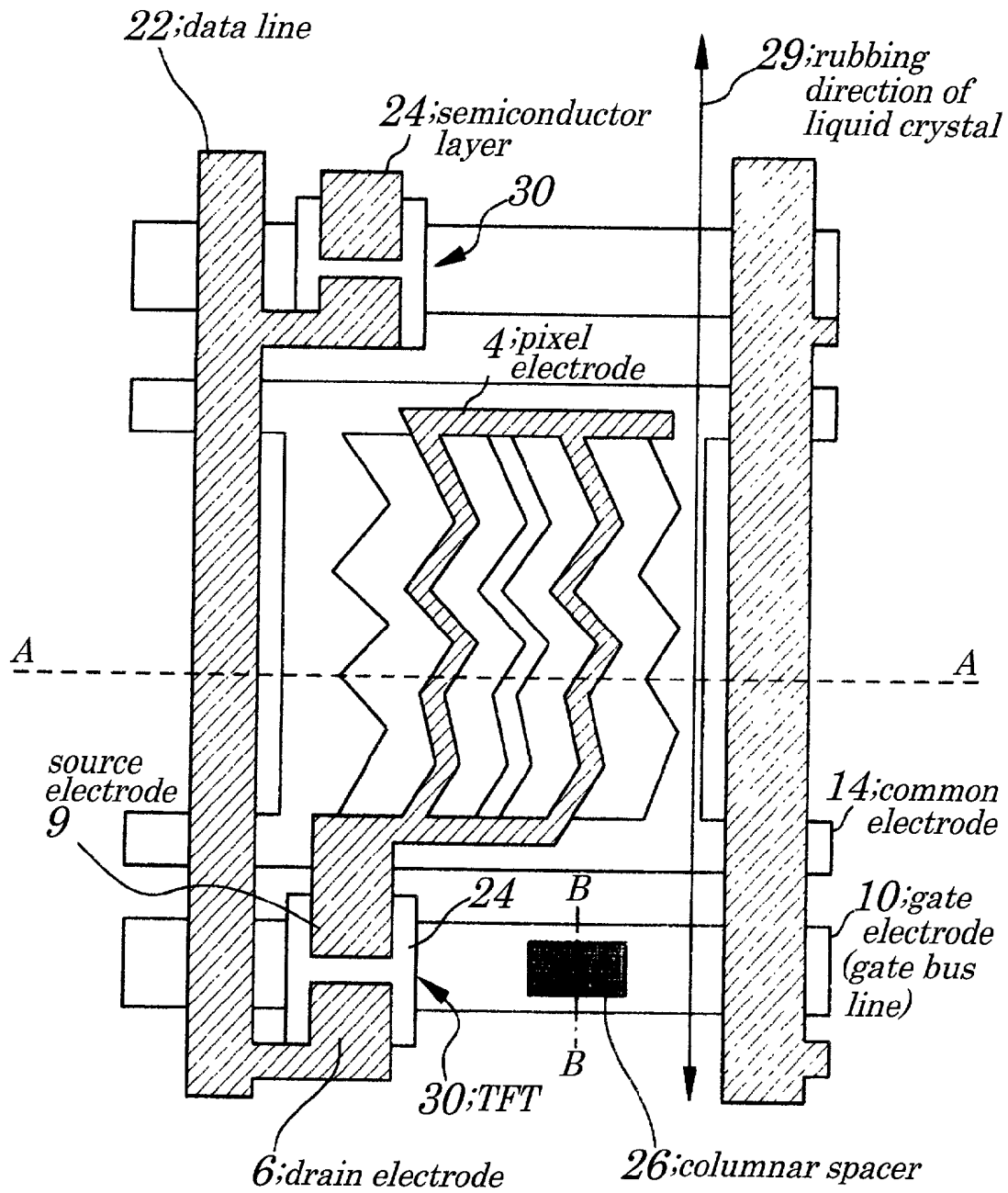

FIG. 2

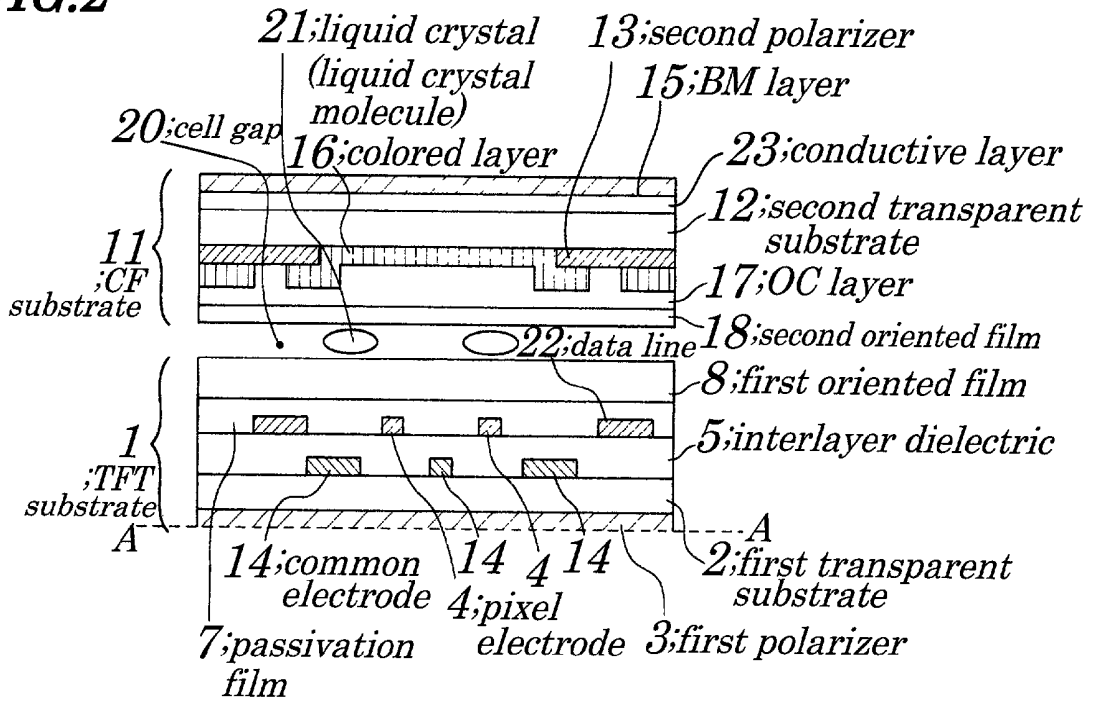

FIG. 3

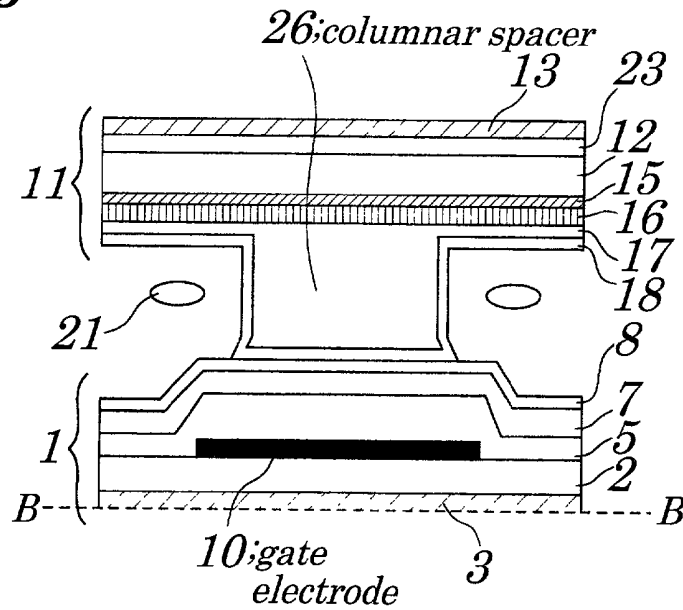

FIG. 4A

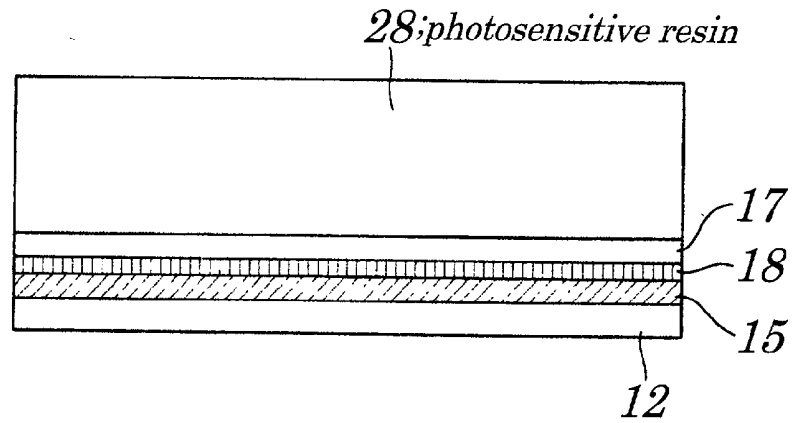

FIG. 4B

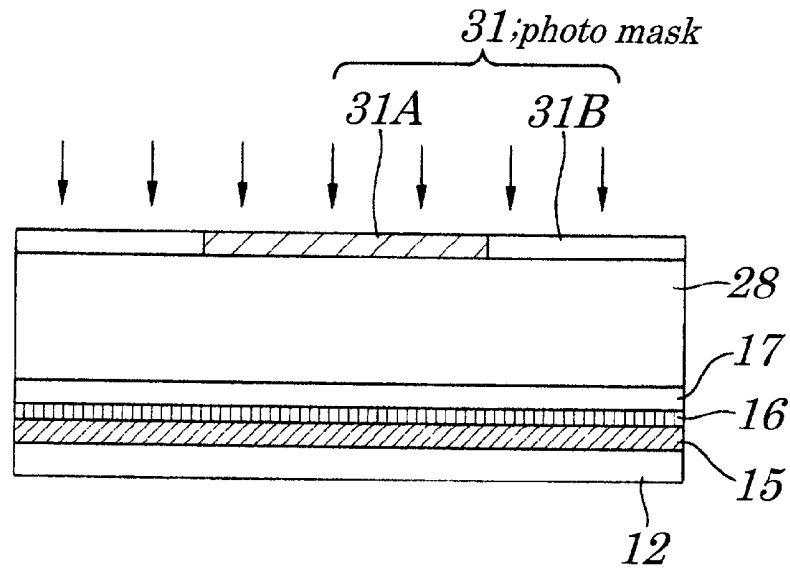

FIG. 4C

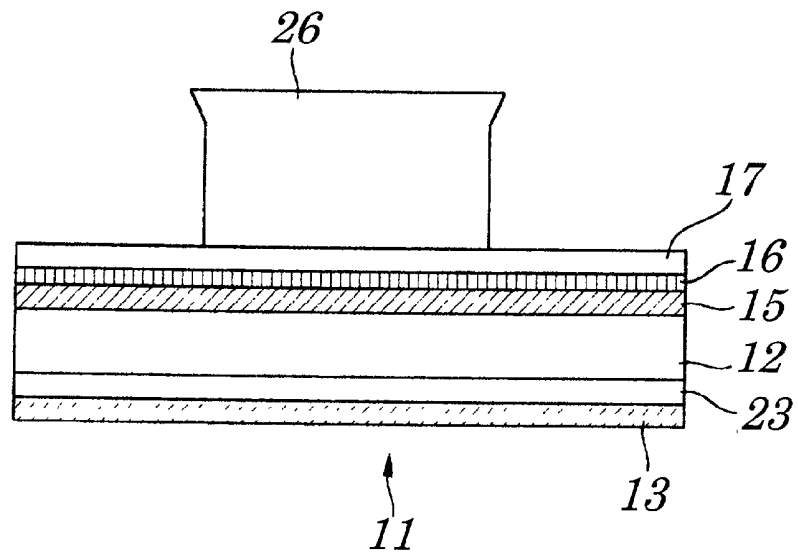

FIG. 5

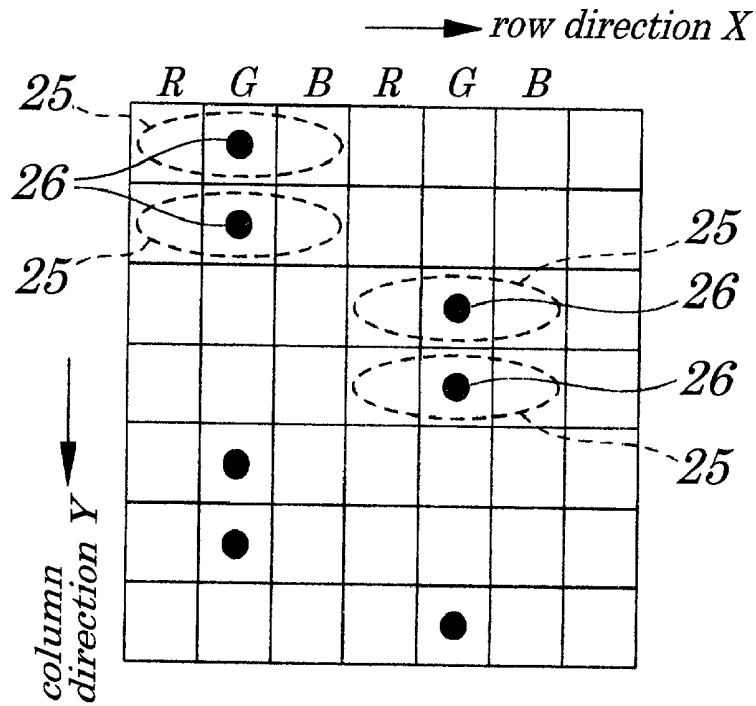

FIG. 6

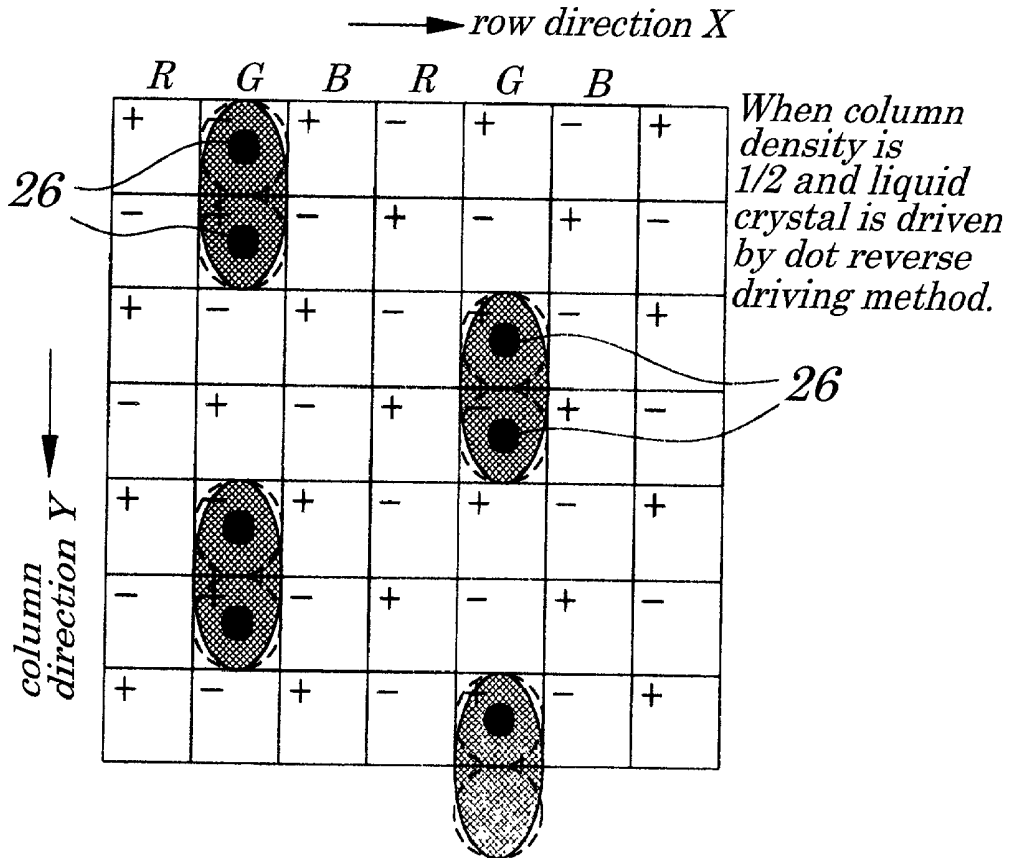
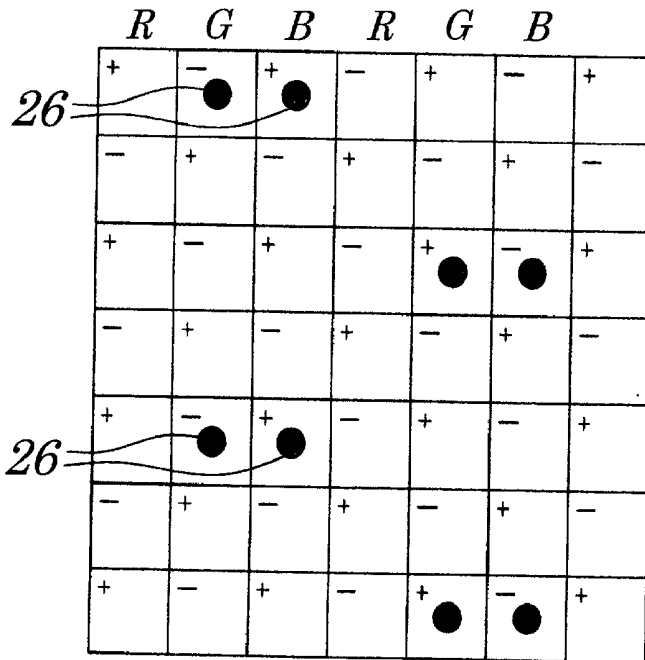
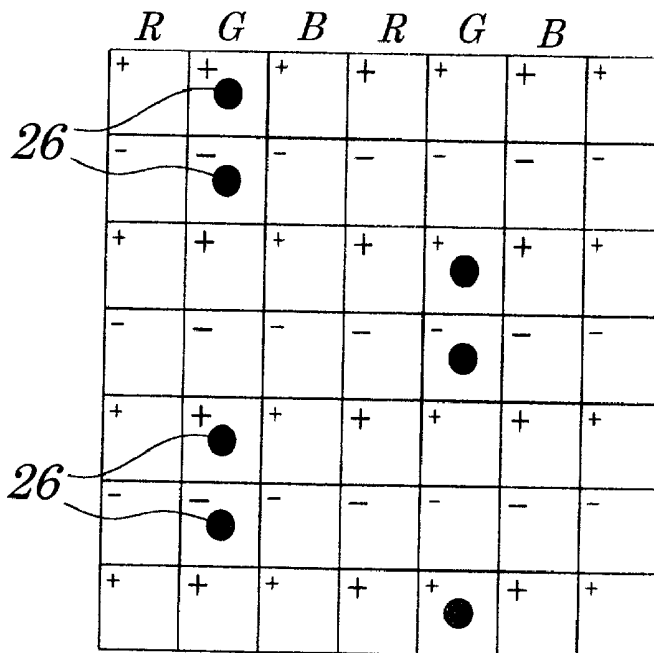

FIG. 7



When column density is 1/2 and liquid crystal is driven by dot reverse driving method.

FIG. 8



When column density is 1/2 and liquid crystal is driven by gate line driving method.

FIG. 9

	<i>R</i>	<i>G</i>	<i>B</i>	<i>R</i>	<i>G</i>	<i>B</i>	<i>R</i>	<i>G</i>	<i>B</i>	<i>R</i>	<i>G</i>	<i>B</i>
	+	-	+	-	+	-	+	-	+	-	+	-
26		□						□				
	-	+	-	+	-	+	-	+	-	+	-	+
26		□						□				
	+	-	+	-	+	-	+	-	+	-	+	-
	-	+	-	+	-	+	-	+	-	+	-	+
				□							□	
	+	-	+	-	+	-	+	-	+	-	+	-
				□							□	
	-	+	-	+	-	+	-	+	-	+	-	+
	+	-	+	-	+	-	+	-	+	-	+	-
		□						□				

When column density is 1/3 and liquid crystal is driven by dot reverse driving method.

FIG. 10

	<i>R</i>	<i>G</i>	<i>B</i>	<i>R</i>	<i>G</i>	<i>B</i>	<i>G</i>	<i>G</i>	<i>G</i>	<i>G</i>	<i>G</i>	<i>G</i>	<i>G</i>	<i>G</i>	<i>G</i>	<i>G</i>	<i>G</i>	<i>G</i>	<i>G</i>	
+	-	+	-	+	-	+	-	+	-	+	-	+	-	+	-	+	-	+	-	+
26		□						□						□					□	
-	+	-	+	-	+	-	+	-	+	-	+	-	+	-	+	-	+	-	+	-
26		□						□						□					□	
+	-	+	-	+	-	+	-	+	-	+	-	+	-	+	-	+	-	+	-	+
-	+	-	+	-	+	-	+	-	+	-	+	-	+	-	+	-	+	-	+	-
+	-	+	-	+	-	+	-	+	-	+	-	+	-	+	-	+	-	+	-	+
-	+	-	+	-	+	-	+	-	+	-	+	-	+	-	+	-	+	-	+	-
+	-	+	-	+	-	+	-	+	-	+	-	+	-	+	-	+	-	+	-	+
-	+	-	+	-	+	-	+	-	+	-	+	-	+	-	+	-	+	-	+	-
+	-	+	-	+	-	+	-	+	-	+	-	+	-	+	-	+	-	+	-	+
-	+	-	+	-	+	-	+	-	+	-	+	-	+	-	+	-	+	-	+	-
+	-	+	-	+	-	+	-	+	-	+	-	+	-	+	-	+	-	+	-	+

When column density is 1/4 and liquid crystal is driven by dot reverse driving method.

FIG. 11

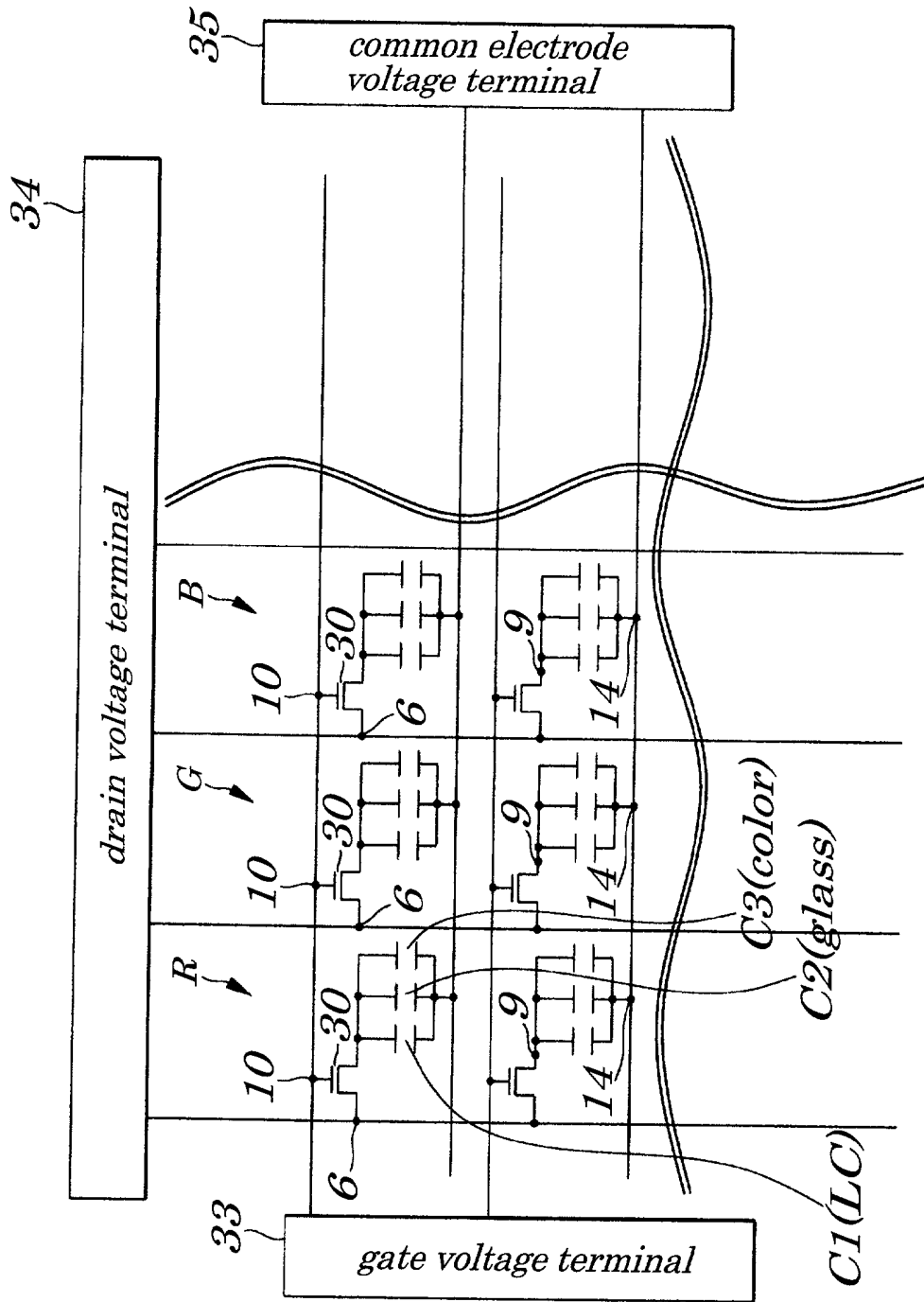

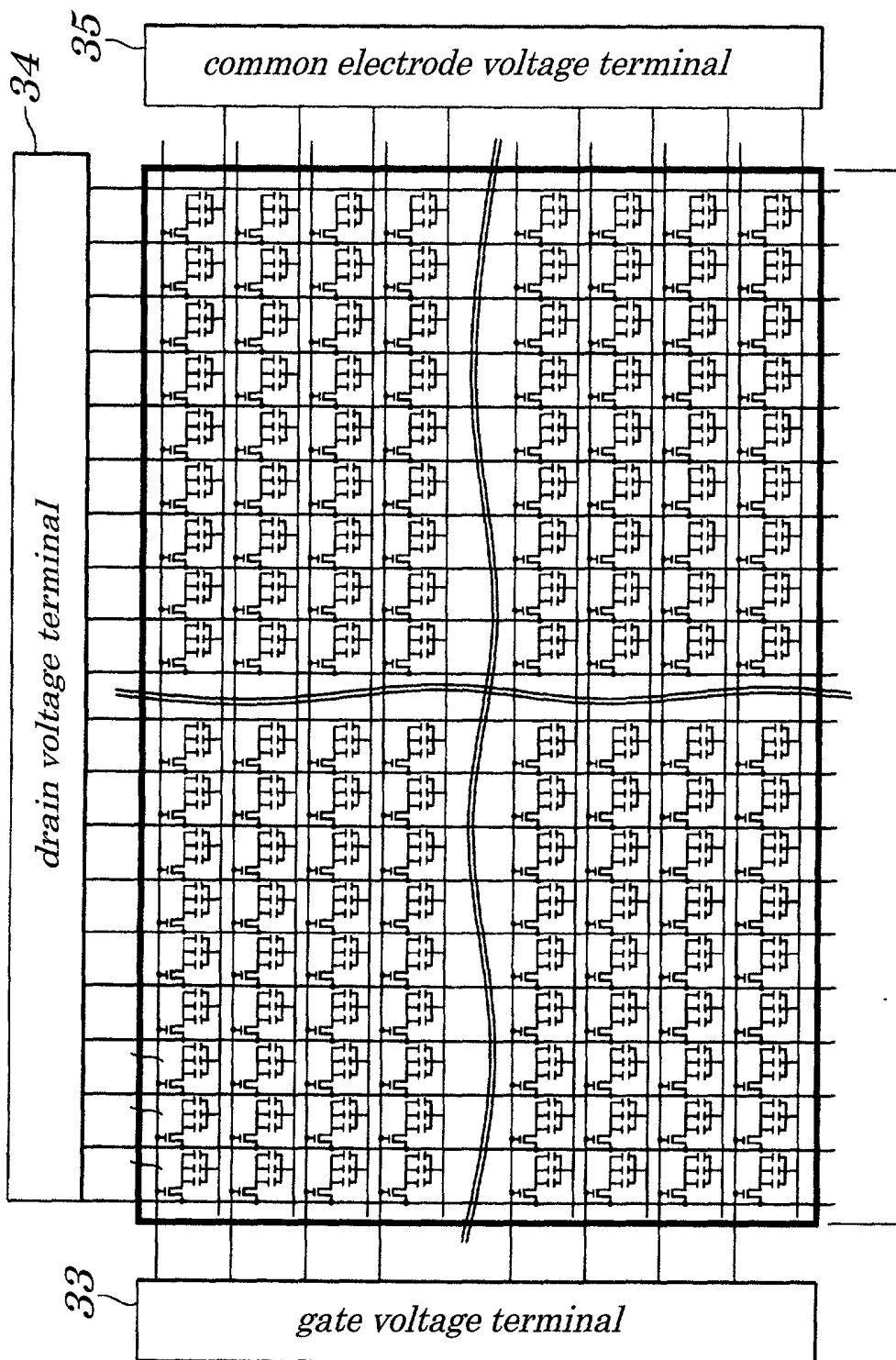
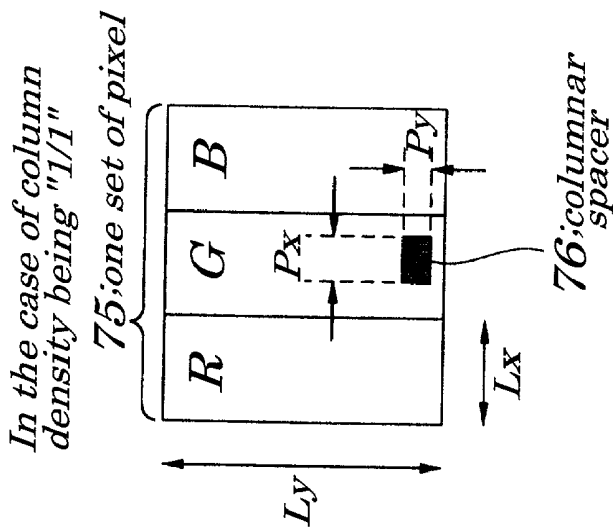

FIG. 12

FIG. 13A



$L_x: 93.5 \mu$ $L_y: 280.5 \mu$
 $P_x: 10 \mu$ $P_y: 15 \mu$

FIG. 13B

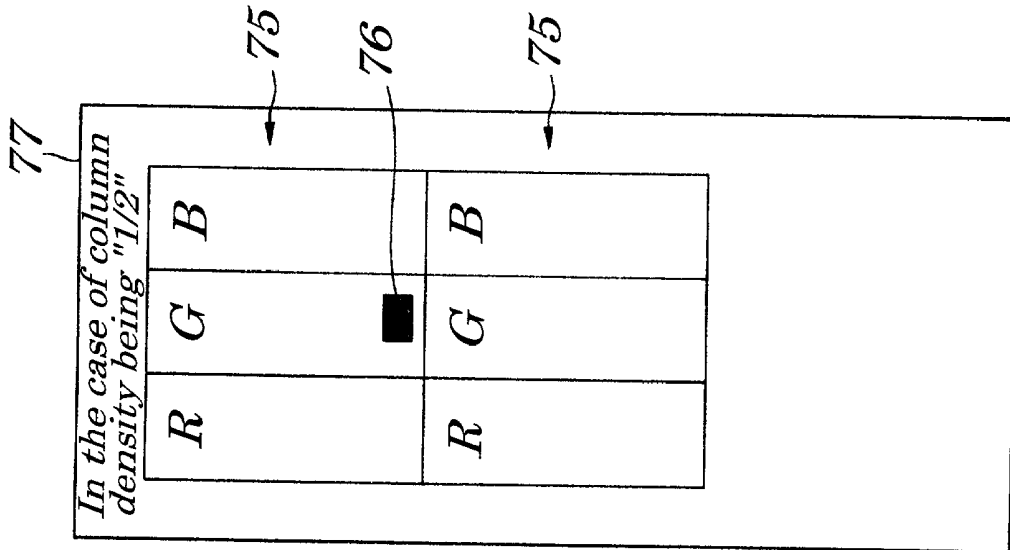

FIG. 13C

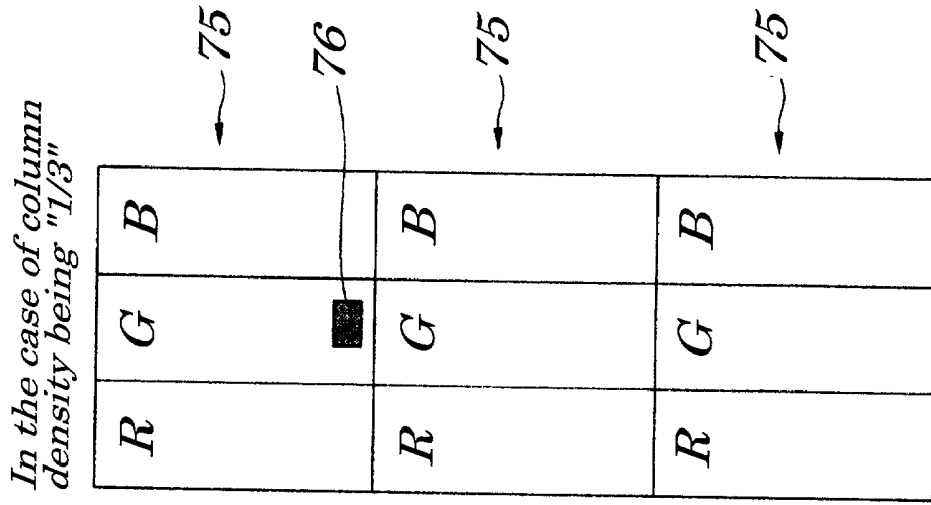
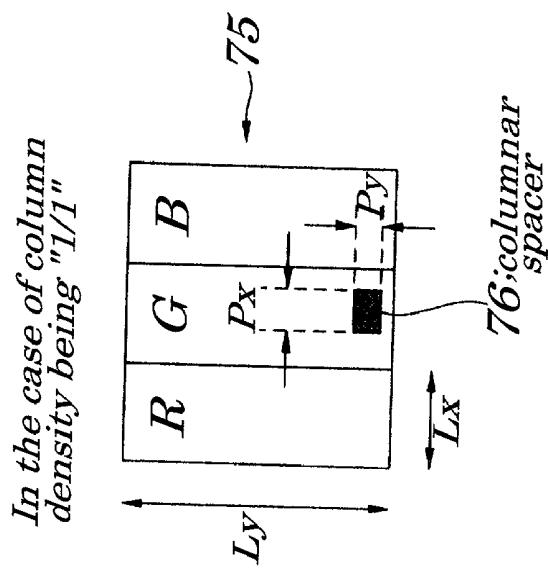

FIG. 14A



$L_x: 93.5 \mu$ $L_y: 280.5 \mu$
 $P_x: 10 \mu$ $P_y: 15 \mu$

FIG. 14B

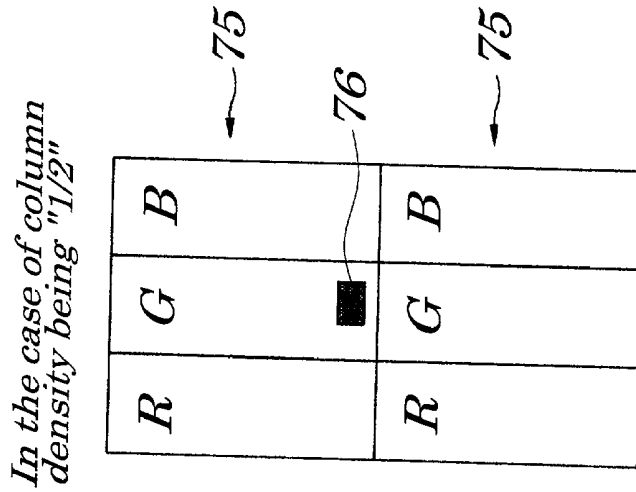

FIG. 14C

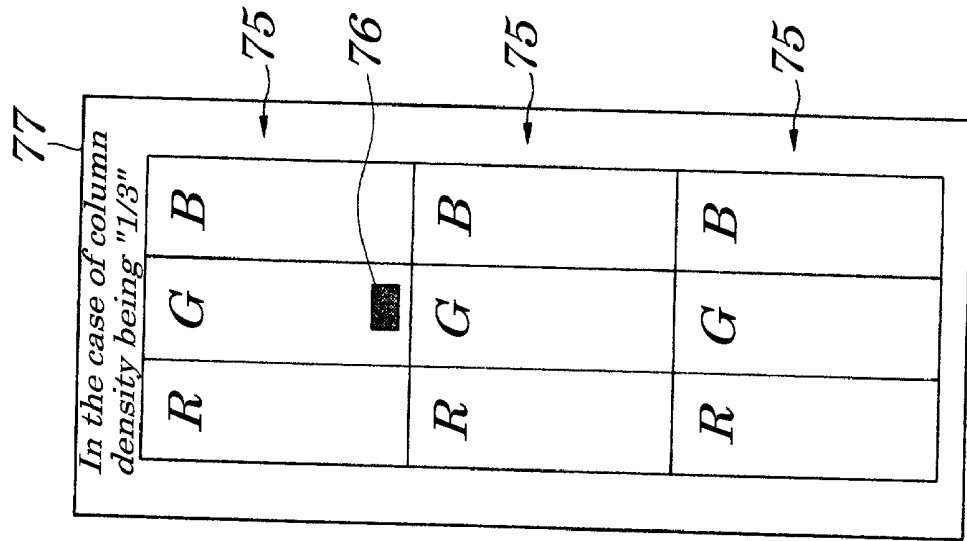

FIG. 17

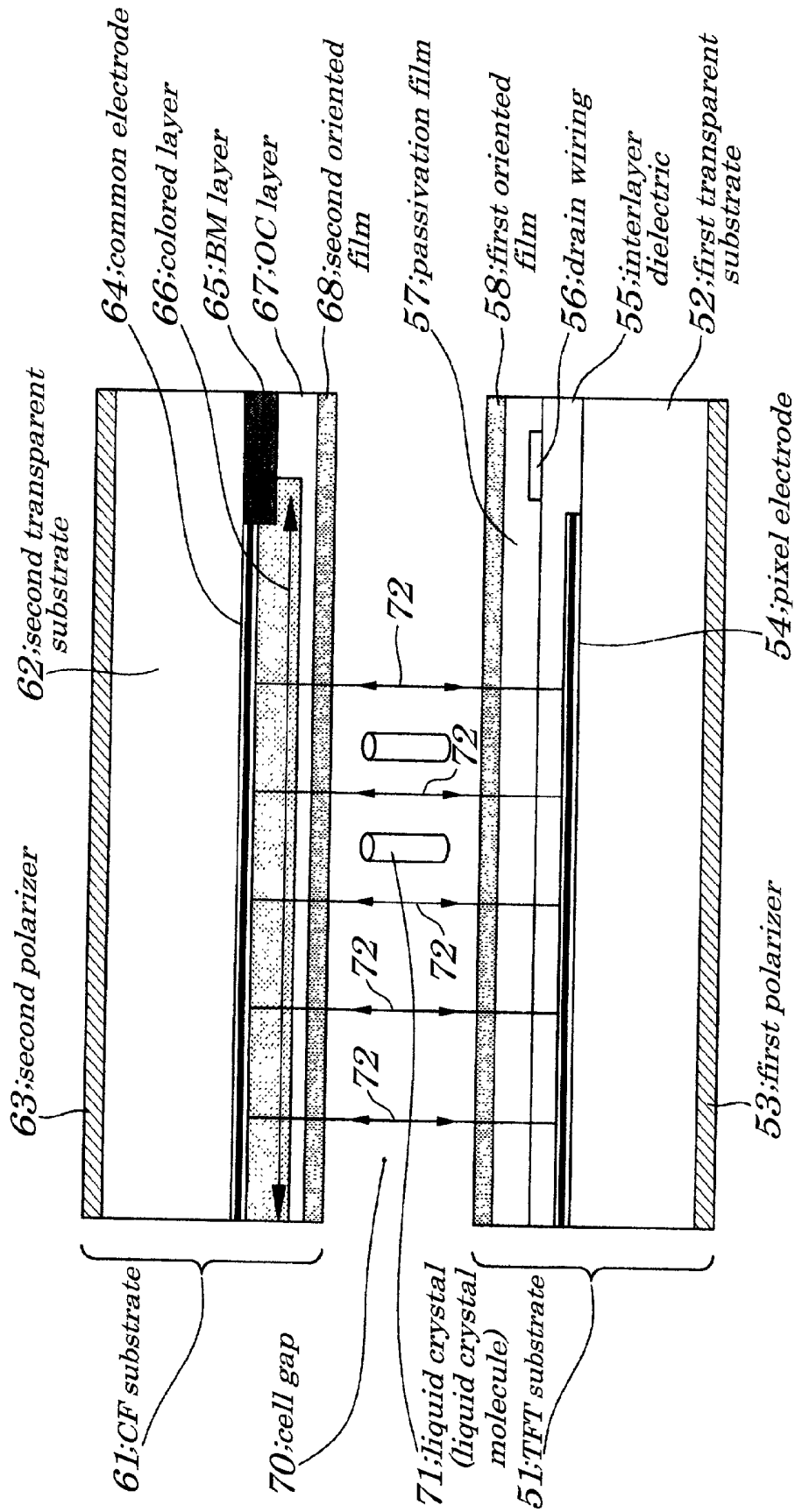
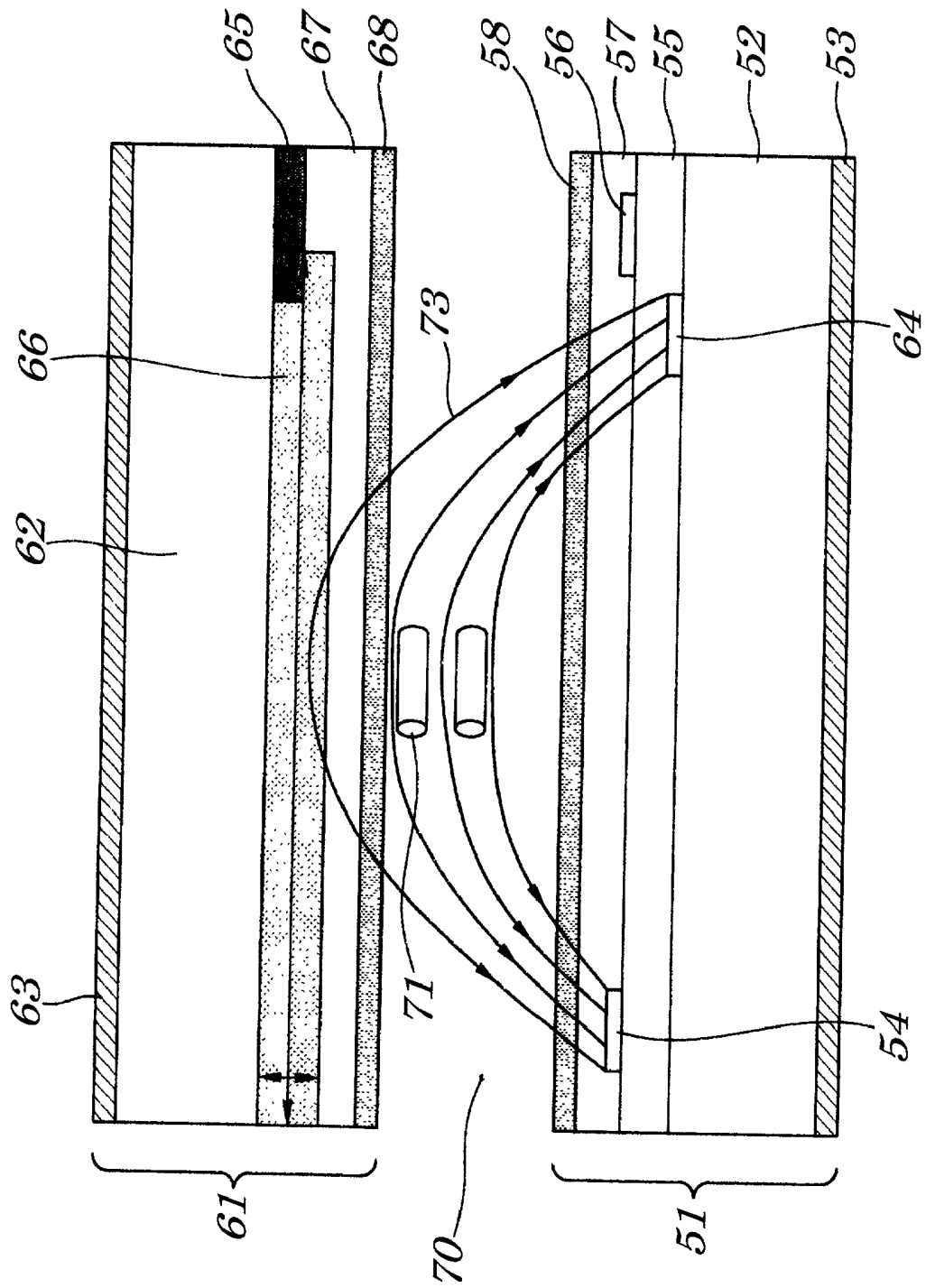

FIG. 18



**LIQUID CRYSTAL DISPLAY DEVICE AND
METHOD FOR MANUFACTURING SAME AND
COLOR FILTER SUBSTRATE**

BACKGROUND OF THE INVENTION

[0001] 1. Field of the Invention

[0002] The present invention relates to a liquid crystal display device and a method for manufacturing the liquid crystal display device and a CF (Color Filter) substrate and more particularly to the liquid crystal display device in which a columnar spacer used to secure a cell gap between the CF substrate on which a colored layer is formed and a TFT (Thin Film Transistor) substrate on which the TFTs are formed, and to the method for manufacturing the liquid crystal display device and the CF substrate.

[0003] The present application claims priority of Japanese Patent Application No.2000-342163 filed on Nov. 9, 2000, which is hereby incorporated by reference.

[0004] 2. Description of the Related Art

[0005] The liquid crystal display device is widely used as a display device of various kinds of information devices or a like. In general the liquid crystal display device is so configured that a liquid crystal is put into a cell gap, in a hermetically sealed manner, between a CF substrate on which a colored layer having a plurality of one set of pixels made up of three kinds of unit pixels including a unit pixel for a red (R) color, a unit pixel for a green (G) color, and a unit pixel for a blue (B) color is formed; and a TFT substrate on which TFTs are adapted to operate as switching elements is formed on a face being opposite to the colored layer. Such the liquid crystal display device is roughly classified into two types, one being a TN (Twisted Nematic)—type liquid crystal display device and another being an IPS (In-Plane Switching)—type liquid crystal display device, depending on its display method.

[0006] FIG. 17 is a cross-sectional view schematically showing configurations of a conventional TN-type liquid crystal display device. As shown in FIG. 17, a liquid crystal 71 (liquid crystal molecule) is put into a cell gap 70, in a hermetically sealed manner between, between a TFT substrate 51 and a CF substrate 61. Moreover, the TFT substrate 51 includes a first transparent substrate 52 made up of glass or a like, a first polarizer 53 formed on a rear of the first transparent substrate 52, a pixel electrode 54 formed on a surface of the first transparent substrate 52, an interlayer dielectric 55 formed in a manner that it covers the pixel electrode 54, a drain wiring 56 formed on the interlayer dielectric 55, a passivation film 57 formed in a manner that it covers the drain wiring 56, and a first oriented film 58 formed on the passivation film 57.

[0007] The CF substrate 61 includes a second transparent substrate 62 made up of glass or a like, a second polarizer 63 formed on a rear of the second transparent substrate 62, a common electrode 64 formed on a surface of the second transparent substrate 62 and a BM (Black Matrix) layer 65 formed on the surface of the second transparent substrate 62, a colored layer 66 covering the common electrode 64 and the BM layer 65, an OC (Over Coat) layer 67 covering the BM layer 65 and the colored layer 66, and a second oriented film 68 formed on the OC layer 67.

[0008] In the TN-type liquid crystal display device described above, by applying a driving voltage between the pixel electrode 54 of the TFT substrate 51 and the common electrode 64 of the CF substrate 61, an electric field in a longitudinal direction relative to both the TFT substrate 51 and the CF substrate 61, is produced, as indicated by arrows 72.

[0009] FIG. 18 is a cross-sectional view schematically showing configurations of a conventional IPS-type liquid crystal display device. The configurations of the IPS-type liquid crystal display device shown in FIG. 18 differ from those in the TN-type liquid crystal display device described above in that the pixel electrode 54 and the common electrode 64 are formed on the first transparent substrate 52 in the TFT substrate 51 so that the pixel electrode 54 and the common electrode 64 are insulated from each other with the interlayer dielectric 55 being interposed between the pixel electrode 54 and the common electrode 64.

[0010] In such the IPS-type liquid crystal display device as described above, by applying a driving voltage between the pixel electrode 54 and the common electrode 64 formed on the TFT substrate 51, an electric field in a horizontal direction relative to the TFT substrate 51, is produced, as indicated by arrows 73. By configuring above, in the case of the IPS-type liquid crystal display device, a direction of the liquid crystal molecule 71 along the surface of the TFT substrate 51 is determined, which can provide a wider viewing angle compared with the case of the TN-type liquid crystal display device. Therefore, the IPS-type liquid crystal display device (hereinafter, referred to simply as an LCD) is mainly and increasingly used.

[0011] In fabrication of the LCD, in order to secure the cell gap 70, into which the liquid crystal 71 is put in a hermetically sealed manner, between the CF substrate 61 and TFT substrate 51, a columnar spacer (not shown) made up of an insulating material is disposed between the CF substrate 61 and the TFT substrate 51. Though the liquid crystal 71 is put in a hermetically sealed manner between the CF substrate 61 and the TFT substrate 51, the liquid crystal 71 expands or shrinks depending on a change in ambient temperatures. Therefore, the columnar spacer has to be disposed so that a liquid crystal panel is formed in a manner that it is somewhat crushed at ordinary temperatures. Moreover, the columnar spacer has to be disposed so that the cell gap 70 is formed uniformly within faces being opposite to each other between both the CF substrate 61 and TFT substrate 51. However, there is a "trade-off" between these two needs. To satisfy these two needs simultaneously, a columnar area ratio CA defined as below has to be set within a range, as a precondition. The columnar area ratio CA is defined as follows:

$$\text{Columnar area ratio } CA = (Px) \cdot (Py) / (Lx) \cdot (Ly)$$

[0012] where Px denotes a horizontal length of the columnar spacer, Py denotes a longitudinal length of the columnar spacer, Lx denotes a horizontal length of each of the unit pixels including the unit pixel for the R color, unit pixel for the G color, and unit pixel for the B color, and Ly denotes a longitudinal length of each of the unit pixels including the R, G, and B color pixels. That is, the columnar area ratio CA is defined as a ratio of a cross sectional area of the columnar spacer to an area of each unit pixel.

[0013] The applicant of the present invention has already found that the above two needs can be approximately

satisfied by disposing the columnar spacer so that the above columnar area ratio CA is set within a range of 0.05% to 0.15% (refer to Japanese Laid-open Patent Application No.2001-117103, published on Apr. 27, 2001 after the filing date of Japanese Patent Application No.2000-342163 of which the present application claims priority) On the other hand, to avoid reduction in an effective area of the liquid crystal panel, it is desirous that the number of the columnar spacers is small and its sizes, that is, its horizontal length Px and its longitudinal length Py are small. Size of the columnar spacer is determined depending on fabrication accuracy of photolithography. If the size is too small, it is unstable in terms of strength. Therefore, both the horizontal length Px and the longitudinal length Py are set at approximately 8 μm or more. Moreover, the columnar spacer is disposed on a gate electrode (gate bus line) of the TFT which can provide a uniformly wide and flat place on the TFT substrate 51 and the horizontal length Px and longitudinal length Py have to be set so that they are smaller than a width P(G) (approximately 13 μm) of the gate electrode (not shown). Furthermore, when the horizontal length Px and longitudinal length Py of the columnar spacer have to be determined, it is necessary to take into consideration a shift "n" (approximately 3 μm or more) in superposition of the TFT substrate 51 on the CF substrate 61.

[0014] Also, when the columnar spacer is disposed, consideration has to be given to a column density. The column density is defined as a ratio of the number of columnar spacers to one set of pixels 75 made up of three kinds of unit pixels for R, G, and B colors. For example, as shown in FIG. 13A, when one columnar spacer 76 is disposed at any one (for example, the unit pixel for G color) of the unit pixels contained in one set of pixels 75, the column density is defined as "1/1". Moreover, as shown in FIG. 13B, when one columnar spacer 76 is arranged in two sets of the pixel 75, the column density is defined as "1/2". As shown in FIG. 13C, when one columnar spacer 76 is arranged in three sets of the pixel 75, the column density is defined as "1/3". This means that, when the configuration shown in FIG. 13A having the column density being "1/1" is considered as a standard configuration, the columnar spacer 76 in the configuration shown in FIG. 13B having the column density being "1/2" is thinned out, that is, the number of the columnar spacers 76 is reduced by a half and in the configuration shown in FIG. 13C having the column density being "1/3", the number of the column spacers 76 is reduced by one third.

[0015] If the horizontal length Lx and longitudinal length Ly of each of the unit pixels for the R, G, and B colors, and the horizontal length Px and longitudinal length Py of the columnar spacer 76 in FIGS. 13A to 13C are set at values as shown in a lower part of FIG. 13A, the columnar area ratio CA can be calculated by using the expression shown above and the following values can be obtained.

[0016] ① In the case of the column density being "1/1" → Columnar area ratio ≈ 0.19%

[0017] ② In the case of the column density being "1/2" → Columnar area ratio ≈ 0.095%

[0018] ③ In the case of the column density being "1/3" → Columnar area ratio ≈ 0.063%

[0019] Therefore, when compared with the columnar area ratio CA used as the precondition described above, the

values obtained in the above cases of ② and ③ are within the optimum range (0.05% to 0.15%). However, since a value being close to a mean value of the optimum range is preferable in actual operations, it is desirous that the columnar spacer 76 is disposed so that the configuration having the column density being "1/2" (the case of ②) boxed by a frame 77 shown in FIG. 13B can be provided.

[0020] FIGS. 14A, 14B, and 14C are also diagrams explaining the column density of the columnar spacer 76 in which the horizontal length Lx and longitudinal length Ly of each of the unit pixels remain the same as those in FIGS. 13A to 13C and the horizontal length of Px and longitudinal length Py of the columnar spacer 76 are different from those in FIGS. 13A to 13C.

[0021] The columnar area ratio CA of each of the cases is as follows.

[0022] ① In the case of the column density being "1/1" → Columnar area ratio ≈ 0.285%

[0023] ② In the case of the column density being "1/2" → Columnar area ratio ≈ 0.142%

[0024] ③ In the case of the column density being "1/3" → Columnar area ratio ≈ 0.094%

[0025] Therefore, in the example, values obtained in the cases ② and ③ are within the optimum range of the columnar area ratio CA used as the precondition. However, for the same reason as above, it is desirous that the columnar spacer 76 is disposed so that the configuration having the column density being "1/3" (the case of ③) boxed by a frame 77 shown in FIG. 14C can be provided.

[0026] As described above, by changing the horizontal length Px and longitudinal length Py of the columnar spacer 76, the column density that can satisfy the precondition is changeable. By changing the horizontal length Lx and longitudinal length Ly of each of the unit pixels, the column density that can satisfy the precondition is also changeable. However, when the horizontal length Px and longitudinal length Py of the columnar spacer 76 are to be changed, the change must be within the range of constraints described above.

[0027] FIG. 15 is a top view schematically showing configurations of the conventional LCD in which the columnar spacer 76 is disposed so that the columnar area ratio CA is set within the optimum range used as the precondition and the column density becomes "1/2". As shown in FIG. 15, the conventional LCD is so configured that two columnar spacers 76 are arranged in four sets of the pixel 75 indicated by broken lines (two sets along a row direction and two sets along a column direction), that is, one columnar spacer 76 is arranged in two sets of the pixel 75. Here, the columnar spacer 76 is disposed in, for example, the same unit pixels for G color and also in every other set of pixels 75 in a staggered manner. Thus, by disposing the columnar spacer 76 so that the columnar area ratio CA can satisfy the precondition and the column density becomes "1/2", an elastic compositional deformation of the columnar spacer 76 is well balanced, which enables the columnar spacer 76 to be adaptable to changes in a thickness of the cell gap 70 caused by ambient temperatures.

[0028] However, the conventional LCD has a problem. That is, in the conventional LCD, since the columnar spacer

76 is arranged in the unit pixels for a same color in every other set of pixels **75**, when the liquid crystal **71** is driven, all the columnar spacers **76** bear signal charges being the same in polarity, which causes disturbance in a transverse electric field caused by the signal charge being the same in polarity.

[0029] This problem in the conventional LCD will be explained below by referring to **FIG. 16**. **FIG. 16** is a diagram explaining a method for driving the conventional LCD. The liquid crystal making up the LCD has a property that it is crushed by continued application of a voltage being the same in polarity (positive or negative). To avoid this, the liquid crystal **71** (not shown in **FIG. 16**) in the conventional LCD is driven by a dot reverse driving method in which a voltage being opposite in polarity is always applied alternately to the same unit pixel. Therefore, as shown in **FIG. 16**, a positive signal charge or a negative signal charge is written alternately in every unit pixel being arranged along the row direction X and a negative signal charge or a positive signal charge is written alternately in every unit pixel being arranged along the column direction Y so that each of the unit pixels adjacent to each other bears the signal charge being opposite in polarity. The reason why the positive or negative voltage is applied alternately to the unit pixels being adjacent to each other is to prevent flicker in displaying.

[0030] If the columnar spacer **76** is disposed in the unit pixels for the same color, for example, the G and G color pixels, for every other set of pixels **75**, as in the case of the conventional LCD shown in **FIG. 15**, since the signal charge being the same in polarity is always written in every other unit having the columnar spacer **76** being arranged in the column direction Y, the signal charge causes the columnar spacer **76** to be electrically charged. That is, the columnar spacer **76** disposed in the unit pixel "G" bears the electrical charge being the same in polarity (positive or negative). As a result, the traverse electrical field is disturbed by influence of the signal charge being the same in polarity. In **FIG. 16**, there is shown a range **78** in which the traverse field is disturbed and shows that the range extends to an entire region in the column direction Y in which the columnar spacer **76** is arranged. On the other hand, since there is no object to be charged in the unit pixel having no columnar spacer **76**, no disturbance in the traverse field occurs.

[0031] In the case of the IPS-type LCD in particular, since a method is employed to decrease specific resistance of the liquid crystal **71** in order to inhibit image retention, when the columnar spacer **76** is electrically charged, the electric charge in the liquid crystal panel gathers and the local specific resistance of the liquid crystal **71** is changed. Therefore, in the conventional LCD whose liquid crystal **71** is driven by the dot reverse driving method, if the columnar spacer **76** is disposed so that it is charged only when the signal charge having one polarity is applied, only electric line of force of the pixel voltage having one polarity enters the columnar spacer **76** and, as a result, the specific resistance of the liquid crystal **71** existing near the columnar spacer **76** is changed, which causes a failure in displaying such as flicker even when the liquid crystal **71** of the LCD is driven by the dot reverse driving method.

SUMMARY OF THE INVENTION

[0032] In view of the above, it is an object of the present invention to provide an LCD which is capable of canceling

out effects of signal charges even when a columnar spacer bears the signal charges and preventing disturbance in a traverse electric field, a method for manufacturing the LCD and a CF substrate.

[0033] According to a first aspect of the present invention, there is provided a liquid crystal display device including:

[0034] a columnar spacer being interposed between a CF substrate and a TFT substrate; and

[0035] wherein a column density of the columnar spacer is smaller than 1 (one) and wherein the columnar spacer is disposed in two unit pixels being adjacent to each other and each bearing a signal charge being opposite in polarity.

[0036] In the foregoing, a preferable mode is one wherein a liquid crystal in the liquid crystal display device is driven by a gate line reverse driving method or a dot reverse driving method.

[0037] According to a second aspect of the present invention, there is provided a liquid crystal display device including:

[0038] a CF substrate on which a colored layer is formed so that unit pixels are arranged in a matrix form;

[0039] a TFT substrate on which TFTs are formed at a place being opposite to the colored layer;

[0040] a columnar spacer formed to secure a cell gap being disposed between the CF substrate and TFT substrate; and

[0041] wherein a liquid crystal is put into the cell gap in a hermetically sealed manner and wherein a columnar area ratio being a ratio of a cross sectional area of the columnar spacer to an area of the unit pixel is set within a range of 0.05% to 0.15% and each columnar spacer making up a pair of the columnar spacers is disposed in each of two unit pixels being arranged in a matrix form and being adjacent to each other at an arbitrary place along a row direction or column direction.

[0042] In the foregoing, a preferable mode is one wherein the unit pixel is driven by a dot reverse driving method when the columnar spacers are arranged along the column direction and wherein the unit pixel is driven by a gate line reverse driving method when the columnar spacers are arranged along the row direction.

[0043] According to a third aspect of the present invention, there is provided a liquid crystal display device including:

[0044] a CF substrate on which a colored layer is formed so that sets of pixels each set being made up of three kinds of unit pixels including a unit pixel for a red (R) color, a unit pixel for a green (G) color, and a unit pixel for a blue (B) color are arranged in a matrix form;

[0045] a TFT substrate on which TFTs are formed at a place being opposite to the colored layer;

[0046] a columnar spacer formed to secure a cell gap being disposed between the CF substrate and TFT substrate; and

[0047] wherein a liquid crystal is put into the cell gap in a hermetically sealed manner and wherein a columnar area ratio being a ratio of a cross sectional area of the columnar

spacer to an area of each unit pixel is set within a range of 0.05% to 0.15% and the columnar spacer is disposed both in one unit pixel making up an arbitrary one set of pixels and in another unit pixel exhibiting a same color as exhibited by the unit pixel in another set of pixels being adjacent to the above one set of pixels along a column direction.

[0048] In the foregoing, a preferable mode is one wherein the unit pixel is driven by a dot reverse driving method.

[0049] According to a fourth aspect of the present invention, there is provided a liquid crystal display device including:

[0050] a CF substrate on which a colored layer is formed so that sets of pixels each being made up of three kinds of unit pixels including a unit pixel for a red (R) color, a unit pixel for a green (G) color, and a unit pixel for a blue (B) color are arranged in a matrix form;

[0051] a TFT substrate on which TFTs are formed at a place being opposite to the colored layer;

[0052] a columnar spacer formed to secure a cell gap being disposed between the CF substrate and the TFT substrate; and

[0053] wherein a liquid crystal is put into the cell gap in a hermetically sealed manner and wherein a columnar area ratio being a ratio of a cross sectional area of the columnar spacer to an area of each unit pixel is set within a range of 0.05% to 0.15% and the columnar spacer is arranged both in one unit pixel making up an arbitrary one set of pixels and in another unit pixel being adjacent to the unit pixel along a row direction.

[0054] In the foregoing, a preferable mode is one wherein the unit pixel is driven by a gate line reverse driving method.

[0055] Also, a preferable mode is one wherein the columnar spacer is disposed on a gate electrode of the TFT formed on the TFT substrate.

[0056] Also, a preferable mode is one wherein a pixel electrode and a common electrode are formed on the TFT substrate in a manner that the pixel electrode and the common electrode are insulated from each other.

[0057] Also, a preferable mode is one wherein, when one columnar spacer is disposed in any one in one set of pixels made up of three kinds of unit pixels including the unit pixel for the R color, the unit pixel for the G color, and the unit pixel for the B color, a column density is defined as $1/1$ and wherein the columnar spacer is arranged so as to lower the column density, even when a plurality of sets of pixels is disposed in a manner that the sets of pixels are adjacent to each other, by reducing the number of the columnar spacers within a range in which the columnar area ratio is satisfied.

[0058] Also, a preferable mode is one wherein the columnar spacer is disposed in a plurality of sets of pixels so that the column density becomes $1/2$.

[0059] According to a fifth aspect of the present invention, there is provided a method for manufacturing a liquid crystal display device including a CF substrate on which a colored layer is formed so that unit pixels are arranged in a matrix form, a TFT substrate on which TFTs are formed at a place being opposite to the colored layer and a columnar spacer formed to secure a cell gap being disposed between the CF

substrate and the TFT substrate wherein a liquid crystal is put into the cell gap in a hermetically sealed manner and, the method including:

[0060] a process of forming the TFT substrate by incorporating at least one TFT in a surface of a first transparent insulating substrate;

[0061] a process of forming the CF substrate by first forming at least one colored layer on a surface of a second transparent insulating substrate being opposite to the TFT and then by forming the columnar spacer on the colored layer; and

[0062] a process of putting the liquid crystal into the cell gap secured by the columnar spacer disposed between the TFT substrate and the CF substrate, in the hermetically sealed manner.

[0063] In the foregoing, a preferable mode is one wherein the process of forming the CF substrate includes a process of first applying a photosensitive resin in a manner so as to cover the colored layer and then performing patterning on the photosensitive resin to form the columnar spacer.

[0064] According to a sixth aspect of the present invention, there is provided a CF substrate for being disposed opposite to a TFT substrate on which TFTs are formed, thereby forming a cell gap between the TFT substrate and the CF substrate, wherein a liquid crystal is put into the cell gap in a hermetically sealed manner, the CF substrate including:

[0065] a colored layer formed on a transparent substrate so that unit pixels are arranged in a matrix form; and

[0066] a columnar spacer is formed on the colored layer.

[0067] In the foregoing, a preferable mode is one wherein the columnar spacer is made up of photosensitive resins.

[0068] With the above configurations, each columnar spacer making up a pair of columnar spacers is disposed in each of two unit pixels being arranged in a matrix manner and being adjacent to each other along a row direction or a column direction at an arbitrary place in a plurality of places where unit pixels are arranged and each columnar spacer making up the pair of the columnar spacers bears a charge being opposite in polarity and therefore effects by a signal charge can be cancelled out. Moreover, when the columnar spacer is incorporated into the CF substrate, lithography technology is employed and therefore easy formation of the columnar spacer is made possible. In configurations of the CF substrate, the columnar spacer is formed on the colored layer and therefore the columnar spacer can be disposed easily at an arbitrary place. As a result, even when the columnar spacer bears the signal charge, the effects by the signal charge can be cancelled out and a disturbance of a traverse electric field can be prevented.

BRIEF DESCRIPTION OF THE DRAWINGS

[0069] The above and other objects, advantages, and features of the present invention will be more apparent from the following description taken in conjunction with the accompanying drawings in which:

[0070] FIG. 1 is a top view showing configurations of an LCD according to a first embodiment of the present invention;

[0071] FIG. 2 is a cross-sectional view of the LCD of FIG. 1 taken along a line A-A;

[0072] FIG. 3 is a cross-sectional view of the LCD of FIG. 1 taken along a line B-B;

[0073] FIGS. 4A, 4B, and 4C are process diagrams illustrating a method of manufacturing a CF substrate making up main components of the LCD, in order of processes, according to the first embodiment of the present invention;

[0074] FIG. 5 is a top view schematically showing configurations of the LCD according to the first embodiment of the present invention;

[0075] FIG. 6 is a diagram showing a method for driving the LCD according to the first embodiment of the present invention;

[0076] FIG. 7 is a top view schematically showing configurations of an LCD according to a second embodiment of the present invention;

[0077] FIG. 8 is a top view schematically showing configurations of an LCD according to a third embodiment of the present invention;

[0078] FIG. 9 is a top view schematically showing configurations of an LCD according to a fourth embodiment of the present invention;

[0079] FIG. 10 is a top view schematically showing configurations of an LCD according to a fifth embodiment of the present invention;

[0080] FIG. 11 is a diagram showing an equivalent circuit of a part of the LCD according to the present invention;

[0081] FIG. 12 is a diagram showing an equivalent circuit of an entire LCD which embodiment of the present invention;

[0082] FIGS. 13A, 13B, and 13C are diagrams explaining column density of a columnar spacer employed in a conventional LCD;

[0083] FIG. 14A, 14B, and 14C are also diagrams explaining column density of a columnar spacer employed in another conventional LCD;

[0084] FIG. 15 is a top view of showing schematic configurations of the conventional LCD;

[0085] FIG. 16 is a diagram explaining a method for driving the conventional LCD;

[0086] FIG. 17 is a cross-sectional view schematically showing configurations of a conventional TN-type liquid crystal display device; and

[0087] FIG. 18 is a cross-sectional view schematically showing configurations of a conventional IPS-type liquid crystal display device.

DETAILED DESCRIPTION OF THE PREFERRED EMBODIMENTS

[0088] Best modes of carrying out the present invention will be described in further detail using various embodiments with reference to the accompanying drawings.

[0089] In the embodiments, as described later in detail, a CF substrate and a TFT substrate are formed with columnar

spacers being interposed between these two substrates in a manner that these two substrates face each other. A column density of the columnar spacer is set to be smaller than 1 (one). The columnar spacers in a pair are so arranged that they are adjacent to each other. Each columnar spacer making up the pair of the columnar spacers is disposed in each of two unit pixels being adjacent to each other, to each of which signals having polarity being opposite to each other are applied.

First Embodiment

[0090] FIG. 1 is a top view showing configurations of an LCD according to a first embodiment of the present invention. FIG. 2 is a cross-sectional view of the LCD of FIG. 1 taken along a line A-A. FIG. 3 is a cross-sectional view of the LCD of FIG. 1 taken along a line B-B. FIGS. 4A to 4C are process diagrams illustrating main processes in a method for manufacturing the LCD according to the first embodiment.

[0091] As shown in FIG. 1 to FIG. 3, in the LCD of the embodiment of the present invention, a liquid crystal 21 (liquid crystal molecule) is put into a cell gap 20, in a hermetically sealed manner, between a TFT substrate 1 and a CF substrate 11. The TFT substrate 1 includes a first transparent substrate 2 made up of glass or a like, a first polarizer 3 formed on a rear of the first transparent substrate 2, a gate electrode (gate bus line) 10 formed on a part of a surface of the first transparent substrate 2, a common electrode 14 formed on another portion of the surface of the first transparent substrate 2, hereby the gate electrode 10 and the common electrode 14 constituting a same layer, an interlayer dielectric 5 formed in a manner so as to cover both the common electrode 14 and the gate electrode 10, a pixel electrode 4 formed on the interlayer dielectric 5, a drain electrode 6 formed also on the interlayer dielectric 5, a data line 22 formed also on the interlayer dielectric 5, a passivation film 7 formed in a manner so as to cover the pixel electrode 4, drain electrode 6 and data line 22, and a first oriented film 8 formed on the passivation film 7.

[0092] Thus, in an IPS-type LCD, the pixel electrode 4 and the common electrode 14 are formed on the first transparent substrate 2 in the TFT substrate 1 in a manner that they are insulated from each other with the interlayer dielectric 5 being interposed between the pixel electrode 4 and the common electrode 14. A TFT 30 includes the drain electrode 6, a source electrode 9, gate the electrode 10, and a semiconductor layer 24. A rubbing direction of the liquid crystal 21 is indicated by a reference number 29.

[0093] The CF substrate 11 includes a second transparent substrate 12, a second polarizer 13 formed on a rear of the second transparent substrate 12 with a conductive layer 23 being interposed between the second transparent substrate 12 and the second polarizer 13, a BM layer 15 formed on a surface of the second transparent substrate 12, a colored layer 16 covering the BM layer 15, an OC layer 17 covering the BM layer 15 and colored layer 16, a columnar spacer 26 formed on a part of the OC layer 17, and a second oriented film 18 formed so as to cover the columnar spacer 26. The columnar spacer 26 is disposed on a surface of the gate electrode (gate bus line) 10 of the TFT 30. The surface of the gate electrode 10 has a uniformly wide and flat surface on the TFT substrate 1. The columnar spacer 26 is adapted to

secure the cell gap **20**. That is, the cell gap **20** in which the liquid crystal **21** is put in the hermetically sealed manner, exists in space being surrounded by the second oriented film **18** covering the columnar spacer **26** and the first oriented film **8**, between the CF substrate **11** and the TFT substrate **1**.

[0094] Next, the method for manufacturing the CF substrate **11** making up main components of the LCD will be described, in order of processes, by referring to FIGS. **4A** to **4C**.

[0095] As shown in FIG. **4A**, first, on the surface of the second transparent substrate **12** made up of glass or a like are formed, in order, the BM layer **15**, the colored layer **16** and the OC layer **17**. Then, by using a photolithography method, a photosensitive resin **28** such as a positive resist is applied on all surfaces of the OC layer **17**.

[0096] Next, as shown in FIG. **4B**, after having covered the photosensitive resin **28** with a photo mask **31** having a light shielding portion **31A** and a light transmitting portion **31B**, exposure treatment (that is, radiation with ultraviolet rays UV) is performed. Then, as shown in FIG. **4C**, by carrying out development treatment, patterning operations are performed on the photosensitive resin **28**. As a result, a part of the photosensitive resin **28** is removed by the exposure to the ultraviolet rays UV applied through the light transmitting portion **31B** of the photo mask **31** and the columnar spacer **26** is formed on the CF substrate **11**. In the embodiment, the columnar spacer **26** is formed at a place corresponding to the gate electrode (gate bus line) **10** on the TFT substrate **1**. The columnar spacer **26** acts so as to secure the cell gap **20**, into which the liquid crystal **21** is to be put in the hermetically sealed manner, between the CF substrate **11** and the TFT substrate **1**. The columnar spacer **26** is formed so as to have a height of $4\ \mu\text{m}$ to $7\ \mu\text{m}$. Moreover, after the liquid crystal **21** has been put, in the hermetically sealed manner, into the cell gap **20** secured by the columnar spacer **26**, a second polarizer **13** is formed on a rear of the CF substrate **11** with the conductive layer **23** interposed between the second polarizer **13** and the CF substrate **11**.

[0097] Then, as shown in FIG. **3**, by using the TFT substrate **1** into which the TFT **30** fabricated in separate processes is incorporated, the liquid crystal **21** is put into the cell gap **20** secured by the columnar spacer **26** between the CF substrate **11** and the TFT substrate **1**, in the hermetically sealed manner, and the LCD is now completed.

[0098] According to the manufacturing method described above, since the columnar spacer **26** is incorporated in the CF substrate **11** by using photolithography technology, easy formation of the columnar spacer **26** is made possible. Moreover, since the CF substrate **11** already having the columnar spacer **26** therewith can be obtained, the columnar spacer **26** can be disposed easily at an arbitrary place between the CF substrate **11** and the TFT substrate **1**.

[0099] In the LCD of the embodiment, as shown in FIG. **5**, the columnar spacer **26** is disposed so that a columnar area ratio CA is set within an optimum range used as a precondition described above and a column density becomes "1/2". Moreover, each columnar spacer **26** making up a pair of the columnar spacers **26** is arranged in each of two unit pixels adjacent to each other in a column direction Y, for example, in a G and G color unit pixels, while the columnar spacer **26** is arranged in the unit pixel in every two unit pixels in a row

direction X, for example, in the G color unit pixel, in a staggered manner. One set of pixels **25** is made up of three unit pixels including a unit pixel for an R color, a unit pixel for the G color and a unit pixel for a B color.

[0100] Next, a method for driving the LCD of the present invention will be explained by referring to FIG. **6**. As shown in FIG. **6**, a positive signal charge or a negative signal charge is written alternately in every unit pixel being arranged along the row direction X and a negative signal charge or a positive signal charge is written alternately in every unit pixel being arranged along the column direction Y so that each of the unit pixels adjacent to each other bears the signal charge being opposite in polarity. Therefore, signal charges each being opposite in polarity are always written in each of the two unit pixels being adjacent to each other in the column direction Y, in each of which each columnar spacer **26** making up the pair of the columnar spacers **26** are disposed. As a result, even when the pair of the columnar spacers **26** is electrically charged, since each columnar spacer **26** making up the pair of the columnar spacers **26** bears the signal charge being opposite in polarity, each columnar spacer **26** making up the pair of the columnar spacers **26** can cancel out effects by the signal charge. Thus, even when the columnar spacer **26** is charged, no disturbance in a traverse electric field occurs, thereby preventing occurrence of a failure in displaying such as flicker.

[0101] As described above, according to the LCD of the first embodiment of the present invention, since the columnar spacer **26** is so disposed that the columnar area ratio CA is set within the optimum range used as the precondition, that each columnar spacer **26** making up the pair of columnar spacers **26** is arranged in each of two unit pixels being adjacent to each other, in order, in the column direction Y, for example, in the G and G color unit pixels, while it is arranged in the unit pixel in every two unit pixels and in a staggered manner in a row direction X, for example, in the G color unit pixel, even when the pair of the columnar spacers **26** is electrically charged, each columnar spacer **26** making up the pair of the columnar spacers **26** bears the signal charge being opposite in polarity and, therefore, the two columnar spacers **26** making up the pair of the columnar spacers **26** can cancel out the effects by the signal charge of each other.

[0102] Moreover, according to the method of manufacturing the LCD, the columnar spacer **26** is incorporated in the CF substrate **11** by performing photolithographic operations, the columnar spacer **26** can be easily formed.

[0103] Therefore, even if the columnar spacer **26** is electrically charged, the effects by the signal charges can be cancelled out and, as a result, the disturbance in the traverse electric field can be prevented.

Second Embodiment

[0104] FIG. **7** is a top view schematically showing configurations of an LCD according to a second embodiment of the present invention. Configurations in the second embodiment differ greatly from those in the first embodiment in that each columnar spacer **26** making up a pair of the columnar spacers **26** is arranged in each of two unit pixels being adjacent to each other in a row direction X.

[0105] That is, in the LCD of the second embodiment, as shown in FIG. **7**, the columnar spacer **26** is disposed so that

a columnar area ratio CA is set within an optimum range used as a precondition described above and a column density becomes "1/2". Moreover, each columnar spacer 26 making up the pair of the columnar spacers 26 is arranged in each of two unit pixels adjacent to each other in the row direction X, for example, in the G and B color unit pixels, while each columnar spacer 26 making up the pair of the columnar spacers 26 is arranged in every two unit pixels in the row direction X and in a staggered manner, for example, in two unit pixels G and B being adjacent to each other.

[0106] The LCD of the second embodiment is driven by a dot reverse driving method as in a case of the first embodiment. Therefore, since approximately a same signal charge as that in the first embodiment is written, a disturbance in a traverse electric field can be prevented. However, in the LCD of the second embodiment, since each columnar spacer 26 making up the pair of the columnar spacers 26 is arranged in each of the two unit pixels being adjacent to each other along the row direction X, as the precondition, a colored layer 16 into which the columnar spacer 26 is incorporated has to be formed so that its thickness is the same in any portion. By forming the pair of the columnar spacers 26 having configurations as described above, a liquid crystal panel can be held in a stable manner.

[0107] Thus, according to the second embodiment, the same effects as obtained in the first embodiment can be achieved.

Third Embodiment

[0108] FIG. 8 is a top view schematically showing configurations of an LCD according to a third embodiment of the present invention. Configurations in the third embodiment differ greatly from those in the first embodiment in that a liquid crystal 21 (FIG. 2) of the third embodiment is driven by a gate line reverse driving method. That is, in the LCD of the embodiment, as shown in FIG. 8, an arrangement of a pair of columnar spacers 26 is the same as in a case of the first embodiment, however, since the liquid crystal 21 is driven by the gate line reverse driving method, a signal charge being the same in polarity is written in every row made up of unit pixels. Therefore, each of the unit pixels making up the two unit pixels being adjacent to each other in a column direction Y in which each columnar spacer making up the pair of the columnar spacers 26 is disposed, bears a signal charge being opposite in polarity, which enables effects by the signal charge to be cancelled out as in the case of the first embodiment.

[0109] Thus, according to the third embodiment, the same effects as obtained in the first embodiment can be achieved.

Fourth Embodiment

[0110] FIG. 9 is a top view schematically showing configurations of an LCD according to a fourth embodiment of the present invention. Configurations in the fourth embodiment differ greatly from those in the first embodiment in that a column density is changed to be "1/3" and each columnar spacer 26 making up a pair of the columnar spacers 26 is disposed in each of two unit pixels being adjacent to each other. That is, in the LCD of the fourth embodiment, as shown in FIG. 9, the columnar spacer 26 is disposed so that a columnar area ratio CA is set within an optimum range used as a precondition described above and the column

density becomes "1/3". Moreover, each columnar spacer 26 making up the pair of the columnar spacers 26 is arranged in each of two unit pixels adjacent to each other in a column direction Y, for example, in a G and G unit pixels, while the columnar spacers 26 are arranged in every two unit pixels in a direction X and in a staggered manner, for example, in the G and G unit pixels being adjacent to each other.

[0111] In the above configurations, though the number of the columnar spacers 26 is small, so long as the columnar area ratio CA is set within the range used as the precondition, there is no problem, that is, effects of a signal charge can be cancelled out.

[0112] Thus, according to the fourth embodiment, the same effects as obtained in the first embodiment can be achieved.

Fifth Embodiment

[0113] FIG. 10 is a top view schematically showing configurations of an LCD according to a fifth embodiment of the present invention. Configurations in the fifth embodiment differ greatly from those in the first embodiment in that a column density is changed to be "1/4" and each columnar spacer 26 making up a pair of the columnar spacers 26 is disposed in each of two unit pixels being adjacent to each other. That is, in the LCD of the fifth embodiment, as shown in FIG. 10, the columnar spacer 26 is disposed so that a columnar area ratio CA is set within an optimum range used as a precondition described above and the column density becomes "1/4". Moreover, each columnar spacer 26 making up the pair of the columnar spacers 26 is arranged in each of two unit pixels adjacent to each other in a column direction Y, for example, in a G and G unit pixels, while the columnar spacers 26 are arranged in every two unit pixels in a direction X and in a staggered manner, for example, in the G and G unit pixels being adjacent to each other.

[0114] In the above configurations, though the number of the columnar spacers 26 is smaller than that in a case of the fourth embodiment, so long as the columnar area ratio CA is set within the range used as the precondition, there is no problem, that is, effects of a signal charge can be cancelled out.

[0115] Thus, according to the fifth embodiment, the same effects as obtained in the first embodiment can be achieved.

[0116] FIG. 11 is a diagram showing an equivalent circuit of a part of the LCD of the present invention. As shown in FIG. 11, to a gate electrode 10 of a TFT 30 making up each of unit pixels for R, G, and B colors is connected a gate voltage terminal 33 and to a drain electrode 6 of the TFT 30 is connected a drain voltage terminal 34. Moreover, to a common electrode 14 is connected a common electrode voltage terminal 35. Between a source electrode 9 of the TFT 30 and the common electrode 14 are connected a capacitor C1 for a liquid crystal 21 (FIG. 2), a capacitor C2 for the TFT substrate 1 made up of glass and a capacitor C3 for a colored layer 16. FIG. 12 is a diagram showing an equivalent circuit of an entire LCD of the present invention.

[0117] It is apparent that the present invention is not limited to the above embodiments but may be changed and modified without departing from the scope and spirit of the invention. For example, in the above embodiments, the pair of the columnar spacers 26 is disposed in the unit pixel "G",

however, they may be arranged in other unit pixels such as an R or B unit pixel. A horizontal or longitudinal length of the columnar spacer **26** may be set arbitrarily so long as the columnar area ratio CA is set within the optimum range used as the precondition. Moreover, in the above embodiment, examples are shown in which the columnar spacers **26** are thinned out based on the optimum columnar area ratio CA. The arrangement in the unit pixel of the columnar spacers **26** employed when they are thinned out is not limited to the above example. The columnar spacers **26** may be arranged arbitrarily so long as they are disposed in unit pixels being adjacent to each other in the row direction X or column direction Y.

What is claimed is:

1. A liquid crystal display device comprising:

a columnar spacer being interposed between a color filter substrate and a thin film transistor substrate; and

wherein a column density of said columnar spacer is smaller than 1 (one) and wherein said columnar spacer is disposed in two unit pixels being adjacent to each other and said each bearing a signal charge being opposite in polarity.

2. The liquid crystal display device according to claim 1, wherein a liquid crystal in said liquid crystal display device is driven by a gate line reverse driving method or a dot reverse driving method.

3. The liquid crystal display device according to claim 1, wherein said columnar spacer is disposed on a gate electrode of said thin film transistor formed on said thin film transistor substrate.

4. The liquid crystal display device according to claim 1, wherein a pixel electrode and a common electrode are formed on said thin film transistor substrate in a manner that said pixel electrode and said common electrode are insulated from each other.

5. A liquid crystal display device comprising:

a color filter substrate on which a colored layer is formed so that unit pixels are arranged in a matrix form;

a thin film transistor substrate on which thin film transistors are formed at a place being opposite to said colored layer;

a columnar spacer formed to secure a cell gap being disposed between said color filter substrate and thin film transistor substrate; and

wherein a liquid crystal is put into said cell gap in a hermetically sealed manner and wherein a columnar area ratio being a ratio of a cross sectional area of said columnar spacer to an area of said unit pixel is set within a range of 0.05% to 0.15% and each said columnar spacer making up a pair of said columnar spacers is disposed in each of two unit pixels being arranged in a matrix form and being adjacent to each other at an arbitrary place along a row direction or column direction.

6. The liquid crystal display device according to claim 5, wherein said unit pixel is driven by a dot reverse driving method when said columnar spacers are arranged along said column direction and wherein said unit pixel is driven by a gate line reverse driving method when said columnar spacers are arranged along said row direction.

7. The liquid crystal display device according to claim 5, wherein said columnar spacer is disposed on a gate electrode of said thin film transistor formed on said thin film transistor substrate.

8. The liquid crystal display device according to claim 5, wherein a pixel electrode and a common electrode are formed on said thin film transistor substrate in a manner that said pixel electrode and said common electrode are insulated from each other.

9. A liquid crystal display device comprising:

a color filter substrate on which a colored layer is formed so that sets of pixels each set being made up of three kinds of unit pixels including a unit pixel for a red color, a unit pixel for a green color, and a unit pixel for a blue color are arranged in a matrix form;

a thin film transistor substrate on which thin film transistors are formed at a place being opposite to said colored layer;

a columnar spacer formed to secure a cell gap being disposed between said color filter substrate and thin film transistor substrate; and

wherein a liquid crystal is put into said cell gap in a hermetically sealed manner and wherein a columnar area ratio being a ratio of a cross sectional area of said columnar spacer to an area of each said unit pixel is set within a range of 0.05% to 0.15% and said columnar spacer is disposed both in one unit pixel making up an arbitrary one set of pixels and in another unit pixel exhibiting a same color as exhibited by said unit pixel in another set of pixels being adjacent to said one set of pixels along a column direction.

10. The liquid crystal display device according to claim 9, wherein said unit pixel is driven by a dot reverse driving method.

11. The liquid crystal display device according to claim 9, wherein said columnar spacer is disposed on a gate electrode of said thin film transistor formed on said thin film transistor substrate.

12. The liquid crystal display device according to claim 9, wherein a pixel electrode and a common electrode are formed on said thin film transistor substrate in a manner that said pixel electrode and said common electrode are insulated from each other.

13. The liquid crystal display device according to claim 9, wherein, when one columnar spacer is disposed in any one in one set of pixels made up of three kinds of unit pixels including said unit pixel for said red color, said unit pixel for said green color, and said unit pixel for said blue color, a column density is defined as 1/1 and wherein said columnar spacer is arranged so as to lower said column density, even when a plurality of sets of pixels is disposed in a manner that said sets of pixels are adjacent to each other, by reducing the number of said columnar spacers within a range in which said columnar area ratio is satisfied.

14. The liquid crystal display device according to claim 13, wherein said columnar spacer is disposed in a plurality of sets of pixels so that said column density becomes 1/2.

15. A liquid crystal display device comprising:

a color filter substrate on which a colored layer is formed so that sets of pixels each being made up of three kinds of unit pixels including a unit pixel for a red color, a

unit pixel for a green color, and a unit pixel for a blue color are arranged in a matrix form;

a thin film transistor substrate on which thin film transistors are formed at a place being opposite to said colored layer;

a columnar spacer formed to secure a cell gap being disposed between said color filter substrate and said thin film transistor substrate; and

wherein a liquid crystal is put into said cell gap in a hermetically sealed manner and wherein a columnar area ratio being a ratio of a cross sectional area of said columnar spacer to an area of each said unit pixel is set within a range of 0.05% to 0.15% and said columnar spacer is arranged both in one unit pixel making up an arbitrary one set of pixels and in another unit pixel being adjacent to said unit pixel along a row direction.

16. The liquid crystal display device according to claim 15, wherein said unit pixel is driven by a gate line reverse driving method.

17. The liquid crystal display device according to claim 15, wherein said columnar spacer is disposed on a gate electrode of said thin film transistor formed on said thin film transistor substrate.

18. The liquid crystal display device according to claim 15, wherein a pixel electrode and a common electrode are formed on said thin film transistor substrate in a manner that said pixel electrode and said common electrode are insulated from each other.

19. The liquid crystal display device according to claim 15, wherein, when one columnar spacer is disposed in any one in one set of pixels made up of three kinds of unit pixels including said unit pixel for said red color, said unit pixel for said green color, and said unit pixel for said blue color, a column density is defined as $1/1$ and wherein said columnar spacer is arranged so as to lower said column density, even when a plurality of sets of pixels is disposed in a manner that said sets of pixels are adjacent to each other, by reducing the number of said columnar spacers within a range in which said columnar area ratio is satisfied.

20. The liquid crystal display device according to claim 19, wherein said columnar spacer is disposed in a plurality of sets of pixels so that said column density becomes $1/2$.

21. A method for manufacturing a liquid crystal display device including a color filter substrate on which a colored

layer is formed so that unit pixels are arranged in a matrix form, a thin film transistor substrate on which thin film transistors are formed at a place being opposite to said colored layer and a columnar spacer formed to secure a cell gap being disposed between said color filter substrate and said thin film transistor substrate wherein a liquid crystal is put into said cell gap in a hermetically sealed manner and, said method comprising:

a process of forming said thin film transistor substrate by incorporating at least one thin film transistor in a surface of a first transparent insulating substrate;

a process of forming said color filter substrate by first forming at least one colored layer on a surface of a second transparent insulating substrate being opposite to said thin film transistor and then by forming said columnar spacer on said colored layer; and

a process of putting said liquid crystal into said cell gap secured by said columnar spacer disposed between said thin film transistor substrate and said color filter substrate, in said hermetically sealed manner.

22. The method for manufacturing the liquid crystal display device according to claim 21, wherein said process of forming said color filter substrate includes a process of first applying a photosensitive resin in a manner so as to cover said colored layer and then performing patterning on said photosensitive resin to form said columnar spacer.

23. A color filter substrate for being disposed opposite to a thin film transistor substrate on which thin film transistors are formed, thereby forming a cell gap between said thin film transistor substrate and said color filter substrate, wherein a liquid crystal is put into said cell gap in a hermetically sealed manner, said color filter substrate comprising:

a colored layer formed on a transparent substrate so that unit pixels are arranged in a matrix form; and

a columnar spacer is formed on said colored layer.

24. The color filter substrate according to claim 23, wherein said columnar spacer is made up of photosensitive resins.

* * * * *

专利名称(译)	液晶显示装置及其制造方法和滤色器基板		
公开(公告)号	US20020054267A1	公开(公告)日	2002-05-09
申请号	US09/986109	申请日	2001-11-07
[标]申请(专利权)人(译)	松本KIMIKAZU		
申请(专利权)人(译)	松本KIMIKAZU WATANABE MAKOTO		
当前申请(专利权)人(译)	松本KIMIKAZU WATANABE MAKOTO		
[标]发明人	MATSUMOTO KIMIKAZU WATANABE MAKOTO		
发明人	MATSUMOTO, KIMIKAZU WATANABE, MAKOTO		
IPC分类号	G02F1/133 G02F1/1335 G02F1/1339 G02F1/1343		
CPC分类号	G02F1/134363 G02F1/13394		
优先权	2000342163 2000-11-09 JP		
其他公开文献	US6897935		
外部链接	Espacenet USPTO		

摘要(译)

本发明提供一种液晶显示装置，即使在柱状间隔物承载信号电荷时也能够消除信号电荷的影响，并且能够防止横向电场的干扰。在上述液晶显示装置中，柱状面积比是柱状衬垫的横截面积与每个单位像素的面积之比，包括用于红色 (R) 颜色的单位像素，用于绿色的单位像素 (G) 颜色，蓝色 (B) 颜色的单位像素设定在0.05%至0.15%的范围内;构成一对柱状间隔物的每个柱状间隔物设置在两个单位像素中的每一个中，所述两个单位像素以矩阵形式排列并且在单位像素为多个位置的任意位置处在行或列方向上彼此相邻。安排。

