



US008107047B2

(12) **United States Patent**
Song

(10) **Patent No.:** **US 8,107,047 B2**
(45) **Date of Patent:** **Jan. 31, 2012**

(54) **LIQUID CRYSTAL DISPLAY APPARATUS**

(75) Inventor: **Jang-Kun Song**, Seoul (KR)

(73) Assignee: **Samsung Electronics Co., Ltd.** (KR)

(*) Notice: Subject to any disclaimer, the term of this patent is extended or adjusted under 35 U.S.C. 154(b) by 0 days.

(21) Appl. No.: **10/719,103**

(22) Filed: **Nov. 21, 2003**

(65) **Prior Publication Data**

US 2004/0252271 A1 Dec. 16, 2004

(30) **Foreign Application Priority Data**

Jun. 12, 2003 (KR) 10-2003-0037835

(51) **Int. Cl.**

G02F 1/1339 (2006.01)
G02F 1/1335 (2006.01)
G02F 1/1333 (2006.01)
G02F 1/1337 (2006.01)

(52) **U.S. Cl.** **349/155**; 349/106; 349/110; 349/129

(58) **Field of Classification Search** 349/42, 349/43, 110, 106, 155, 156, 157, 129
See application file for complete search history.

(56) **References Cited**

U.S. PATENT DOCUMENTS

5,757,451 A * 5/1998 Miyazaki et al. 349/106
5,801,797 A * 9/1998 Iida et al. 349/73

5,969,784 A *	10/1999	Miyazaki et al.	349/155
6,140,988 A *	10/2000	Yamada	345/88
6,317,187 B1 *	11/2001	Nakajima et al.	349/155
6,323,921 B1 *	11/2001	Kurauchi et al.	349/106
6,836,308 B2 *	12/2004	Sawasaki et al.	349/129
2001/0040656 A1 *	11/2001	Na et al.	349/110
2003/0156237 A1 *	8/2003	Lin et al.	349/110
2004/0041963 A1 *	3/2004	Ogishima et al.	349/110

FOREIGN PATENT DOCUMENTS

JP	2002-055350	2/2002
JP	2002-214614	7/2002
KR	10-2002-0071542 A	9/2002

* cited by examiner

Primary Examiner — Nathanael R Briggs

(74) *Attorney, Agent, or Firm* — Innovation Counsel LLP

(57) **ABSTRACT**

A liquid crystal display (LCD) apparatus includes a first panel, a second panel, and a liquid crystal layer disposed between the first and second panels. The first panel includes a first transparent substrate having a pixel area, a thin film transistor disposed at the pixel area so as to output a pixel voltage, a first color filter disposed at the pixel area, the first color filter having a first edge, a second color filter disposed adjacent to the first color filter and having a second edge, the first edge and the second edge being overlapped to provide an overlapped area between the first color filter and the second color filter, a spacer disposed on the overlapped area between the first color filter and the adjacent second color filter, and a pixel electrode disposed on the first color filter so as to receive the pixel voltage. The spacer has a same material as one of the first color filter and the second color filter. The second panel includes a second transparent substrate and a common electrode disposed on the second transparent substrate.

14 Claims, 25 Drawing Sheets

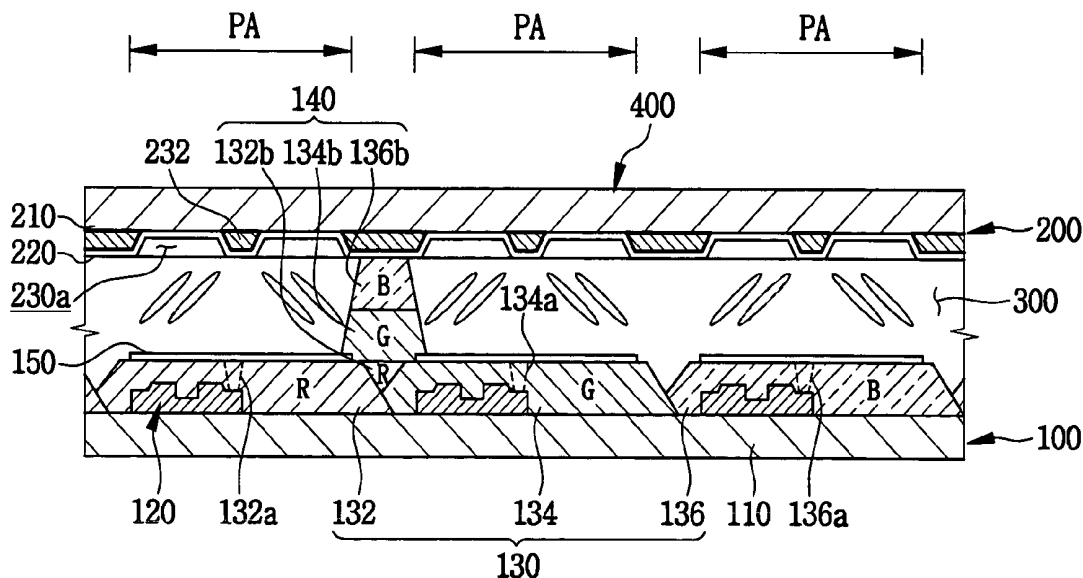

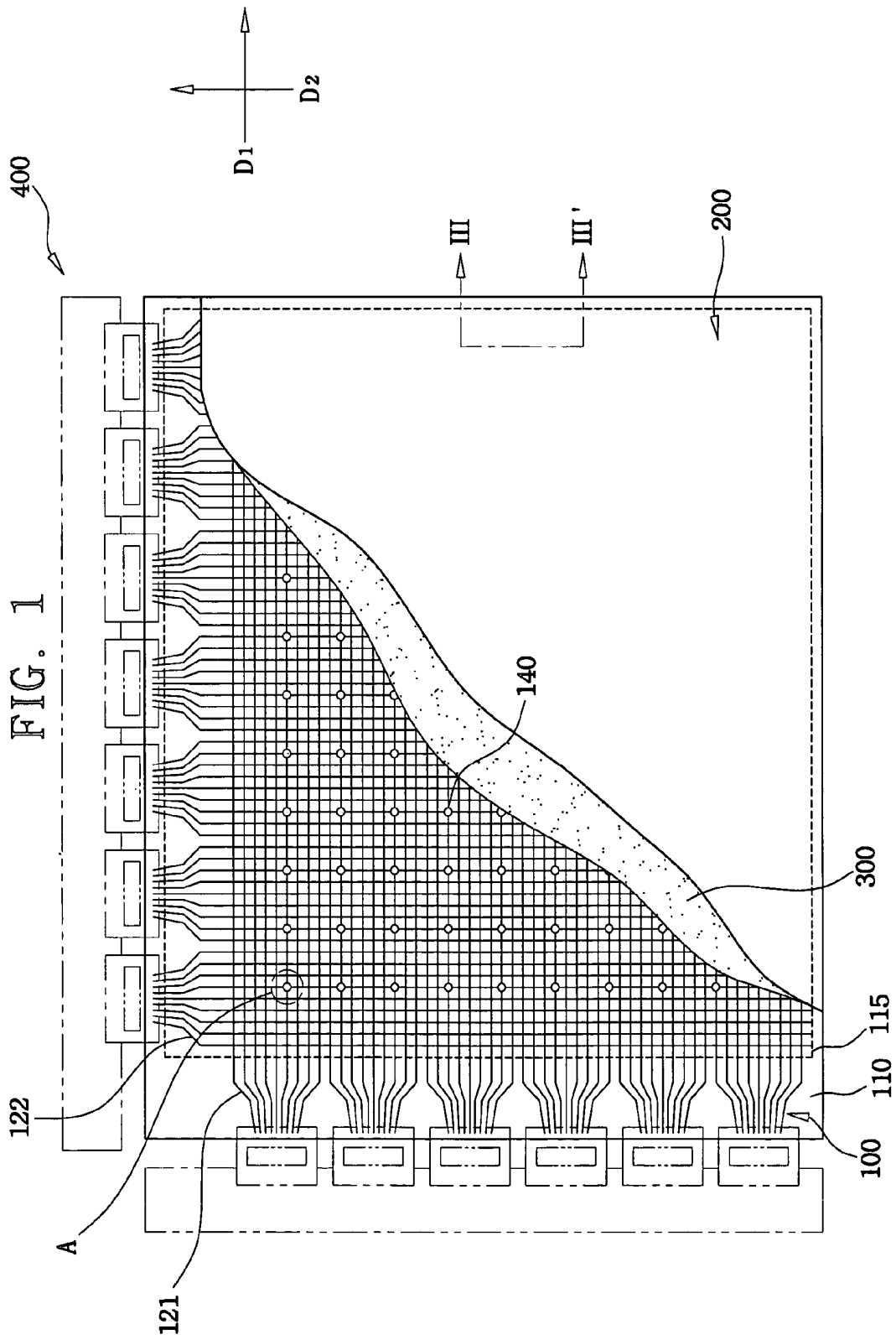

FIG. 2

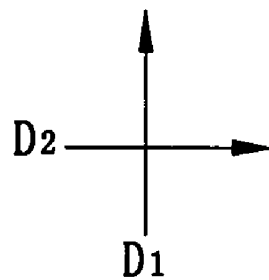
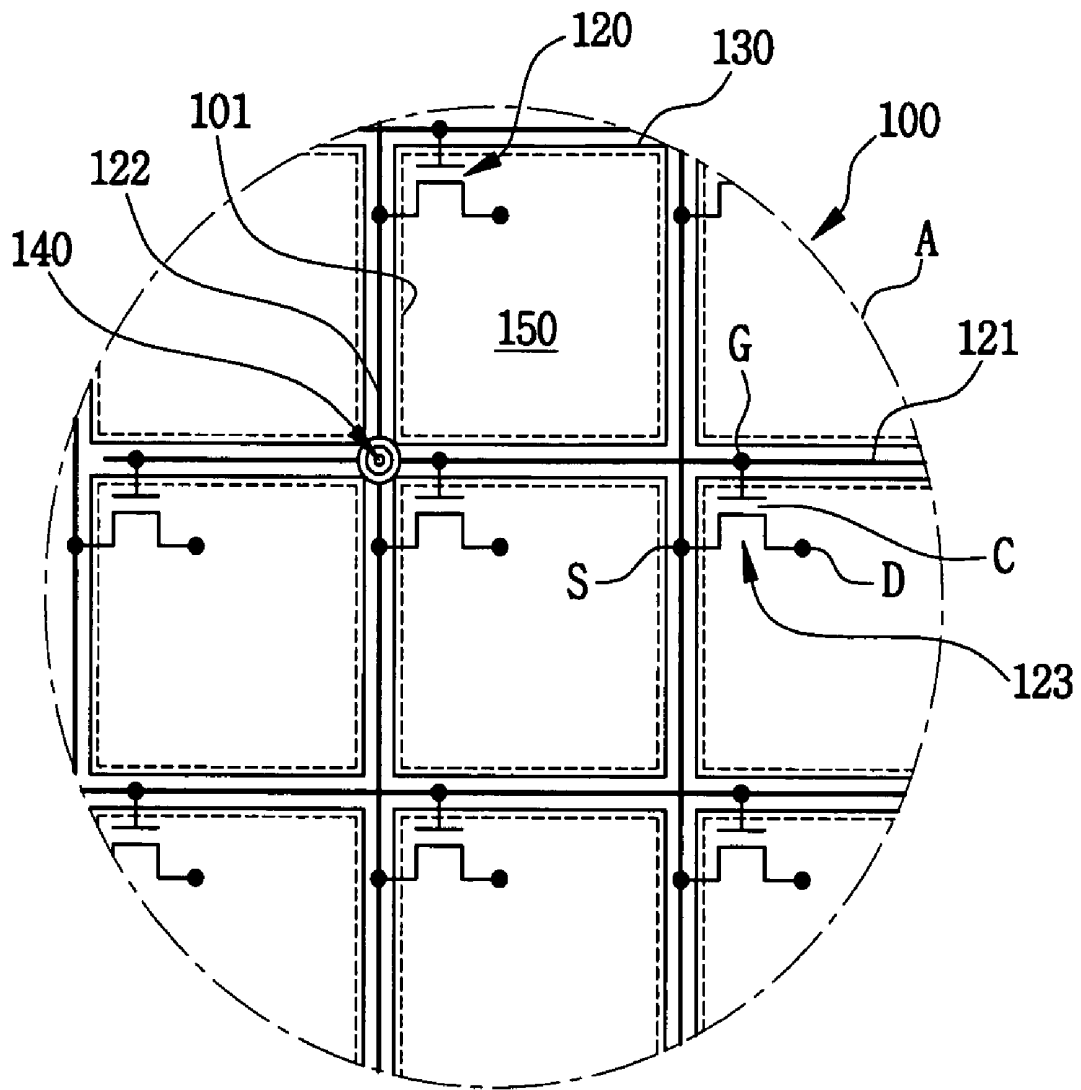

FIG. 7

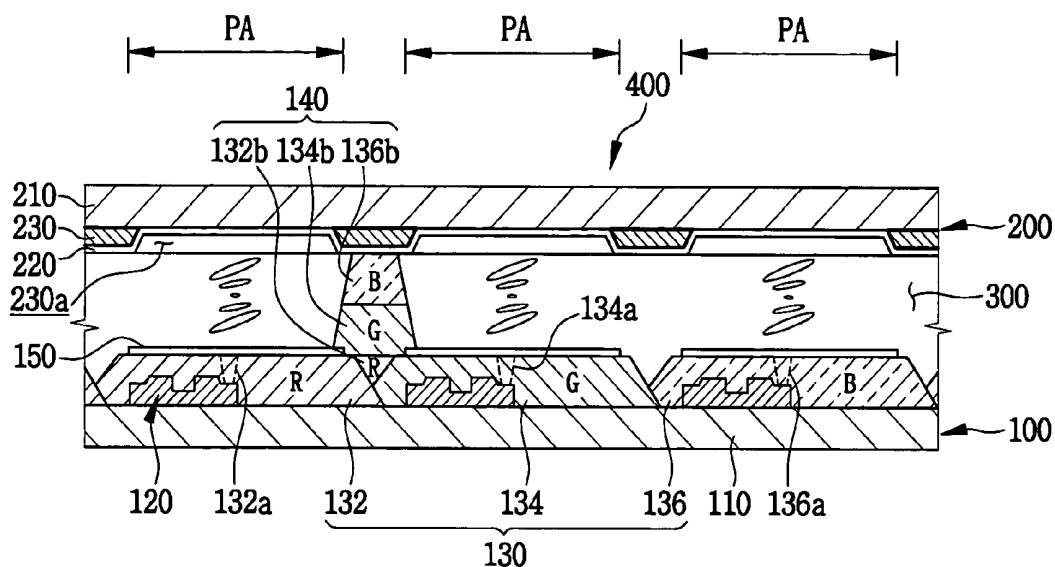

FIG. 8

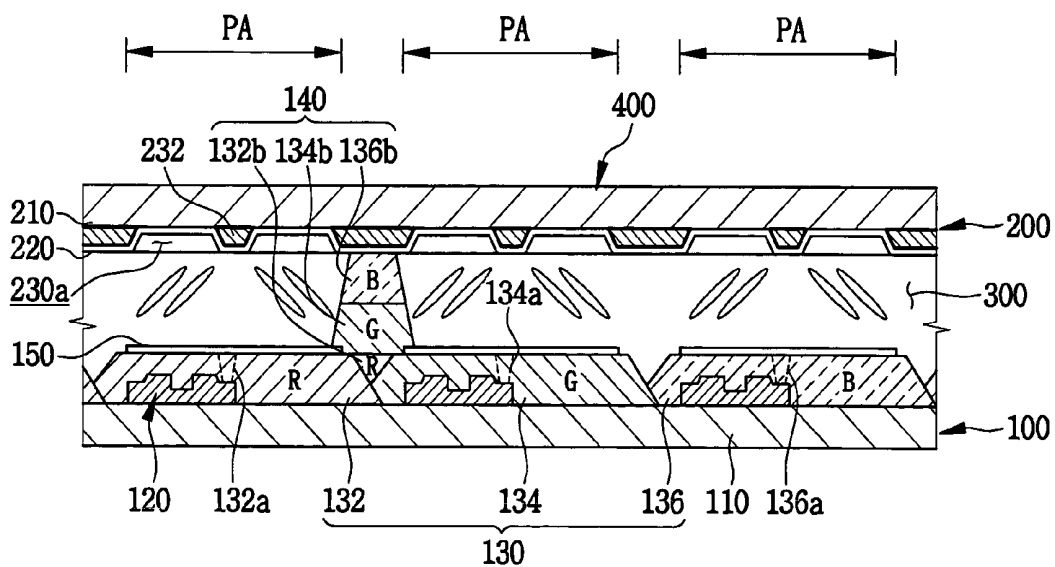

FIG. 9

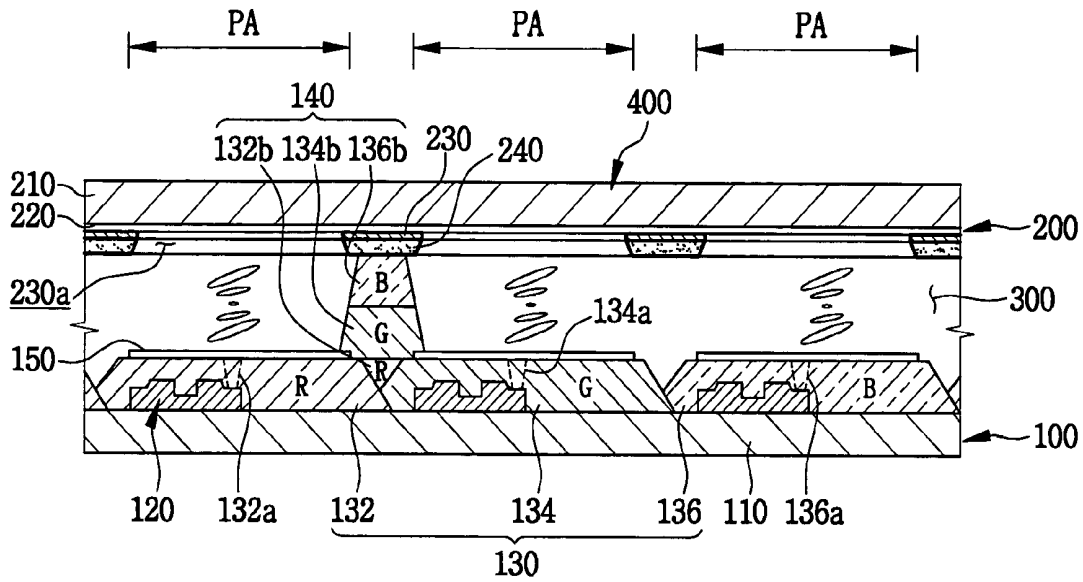

FIG. 10

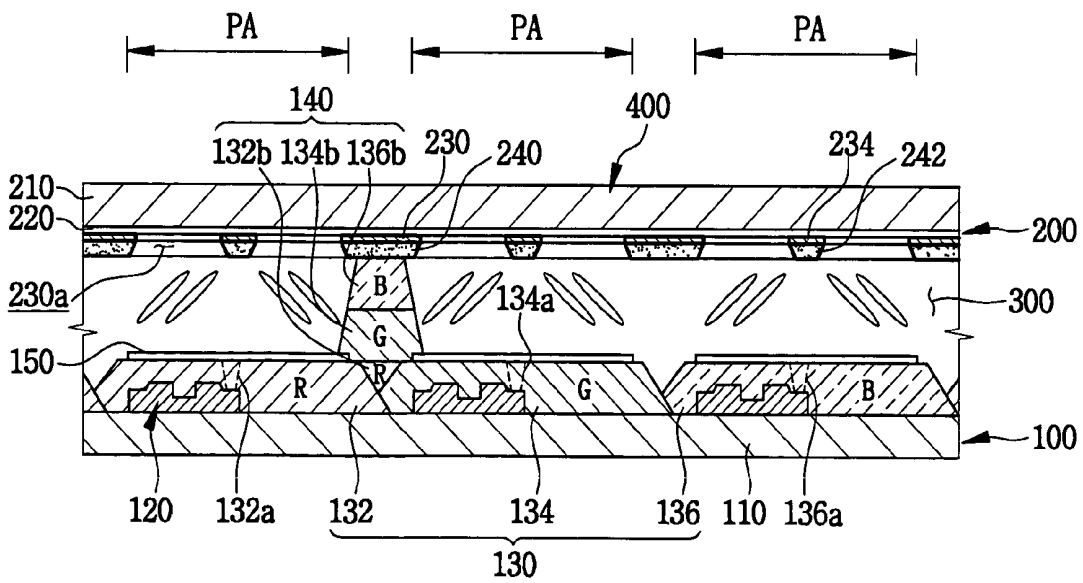

FIG. 11

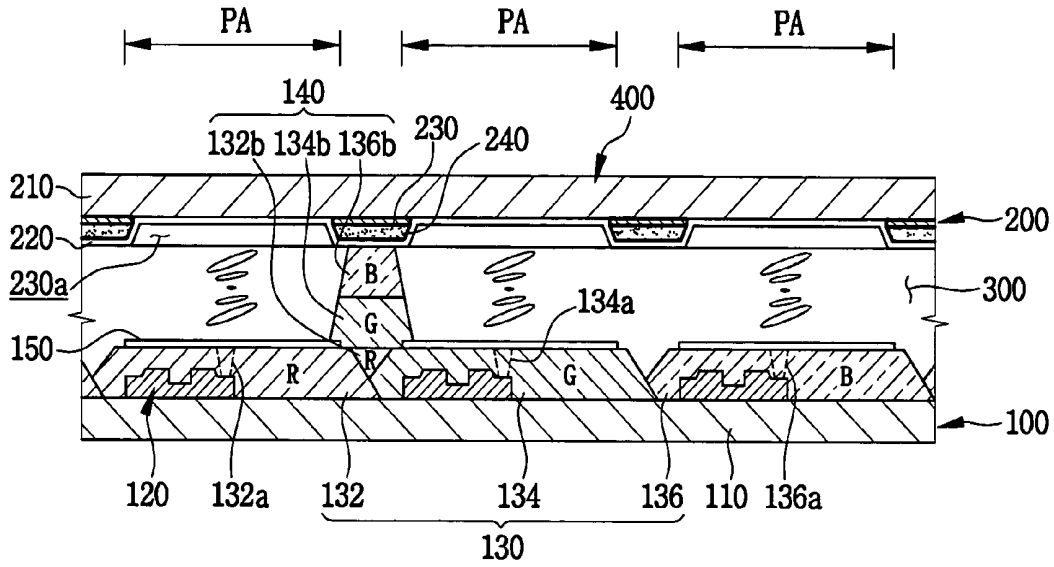

FIG. 12

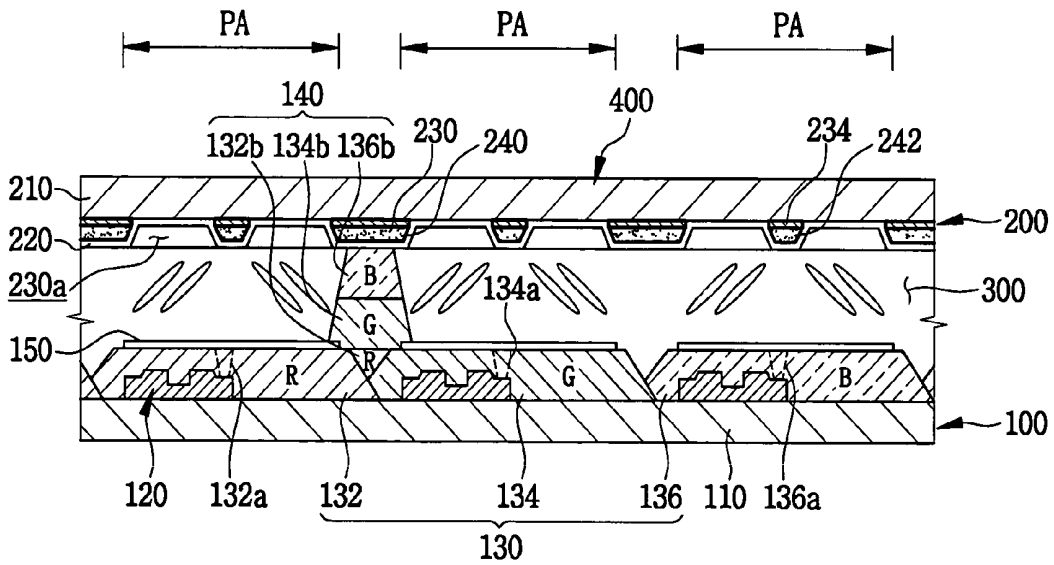

FIG. 13

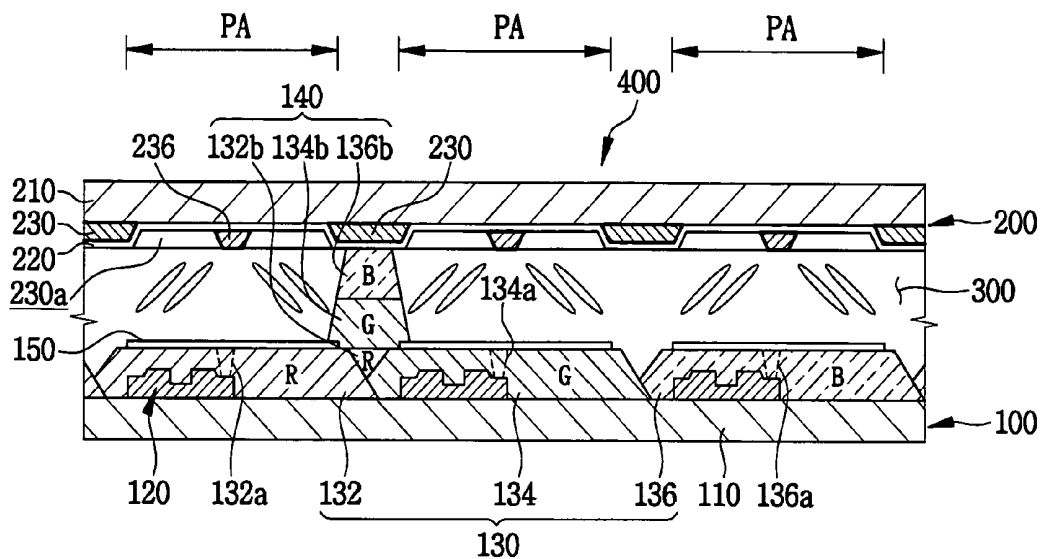

FIG. 14

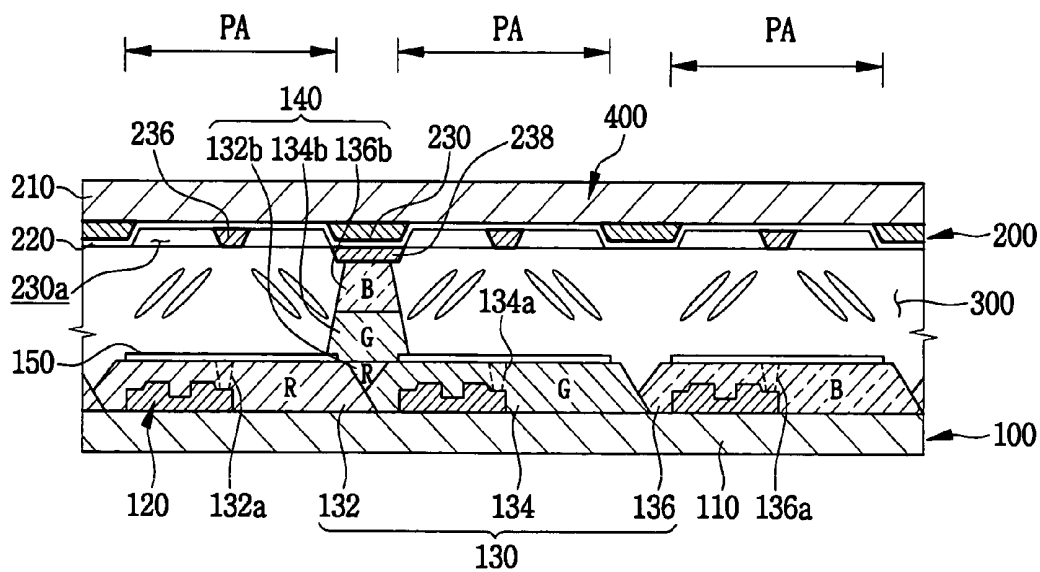

FIG. 15

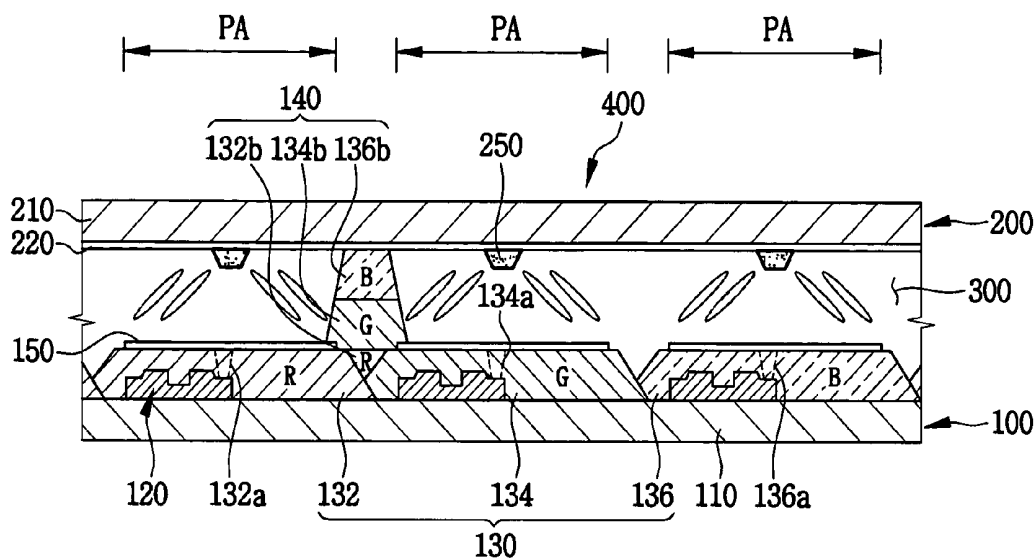

FIG. 16

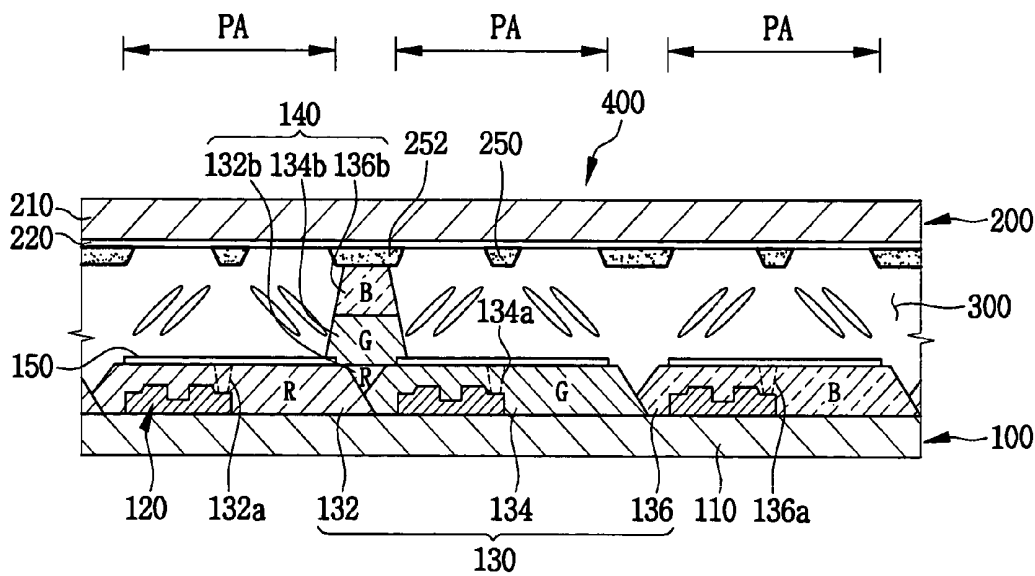

FIG. 17

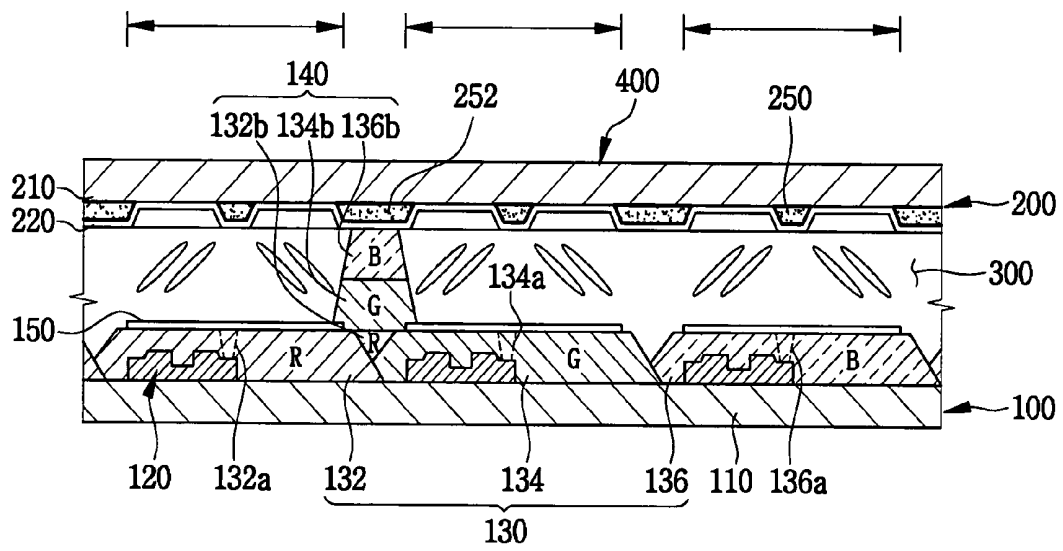

FIG. 18A

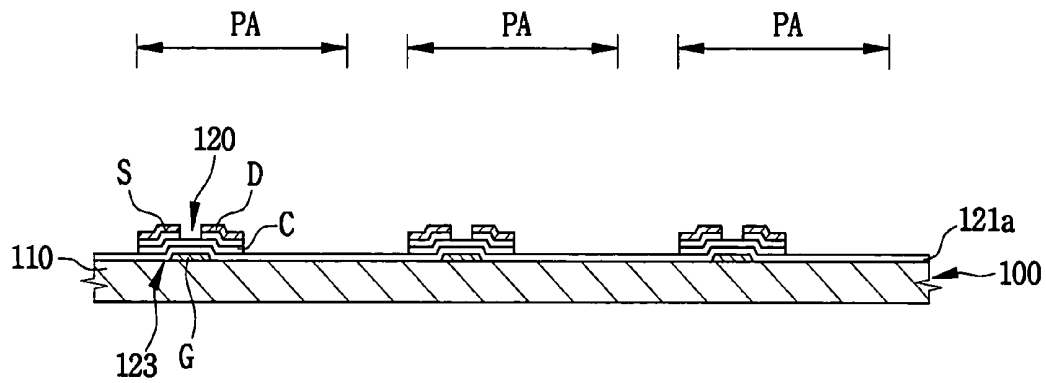

FIG. 18B

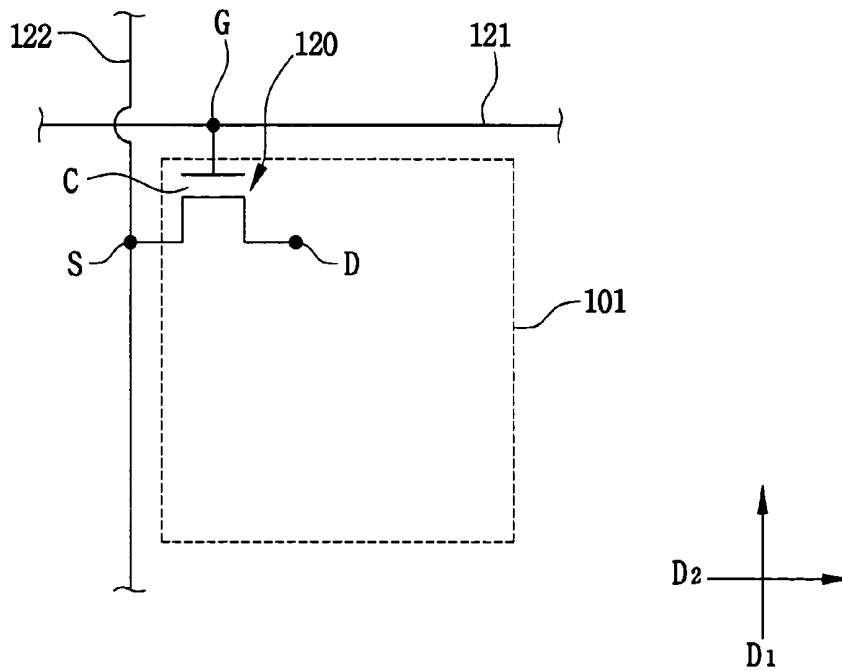

FIG. 19

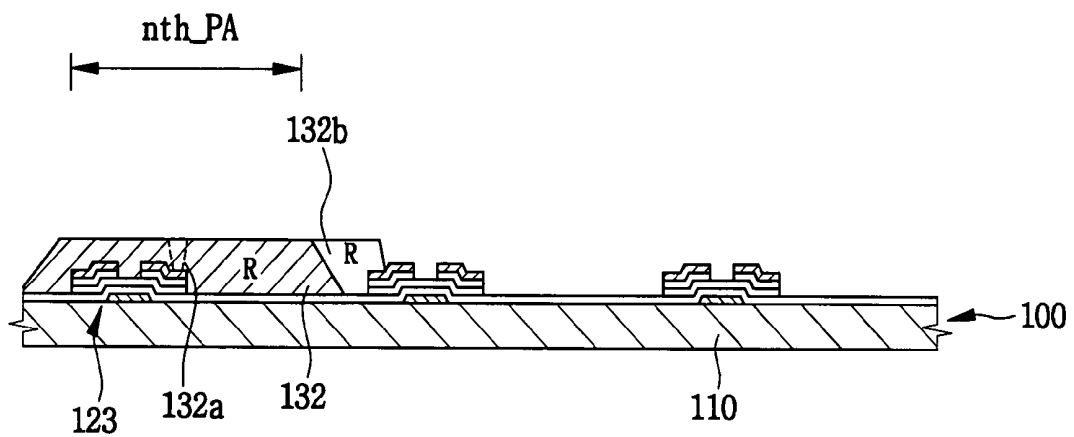

FIG. 20

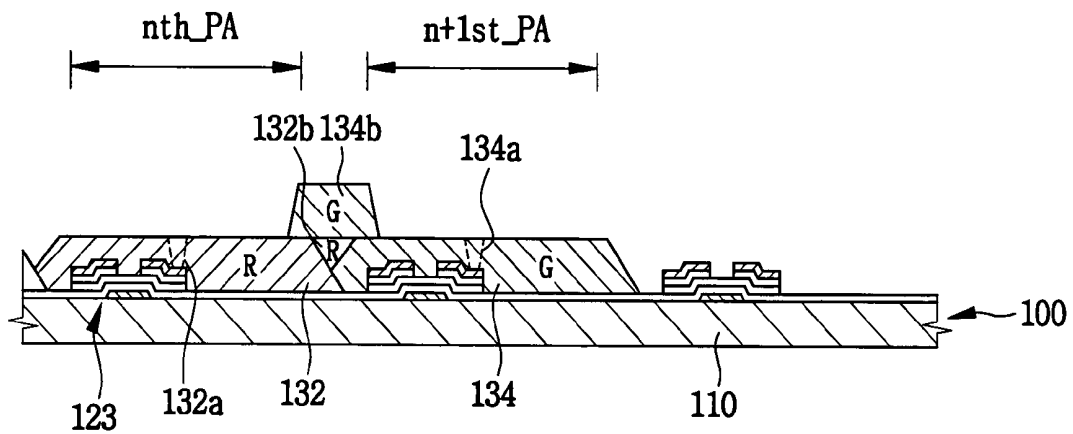

FIG. 21

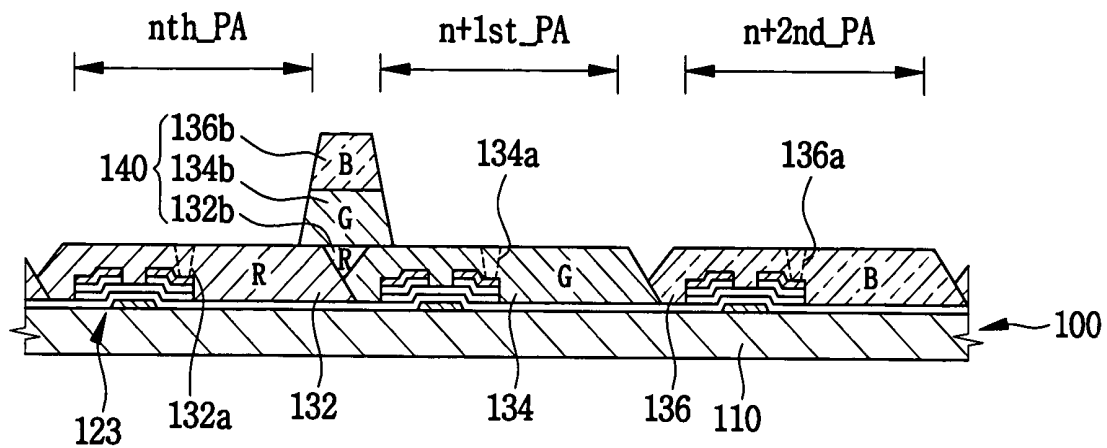

FIG. 22

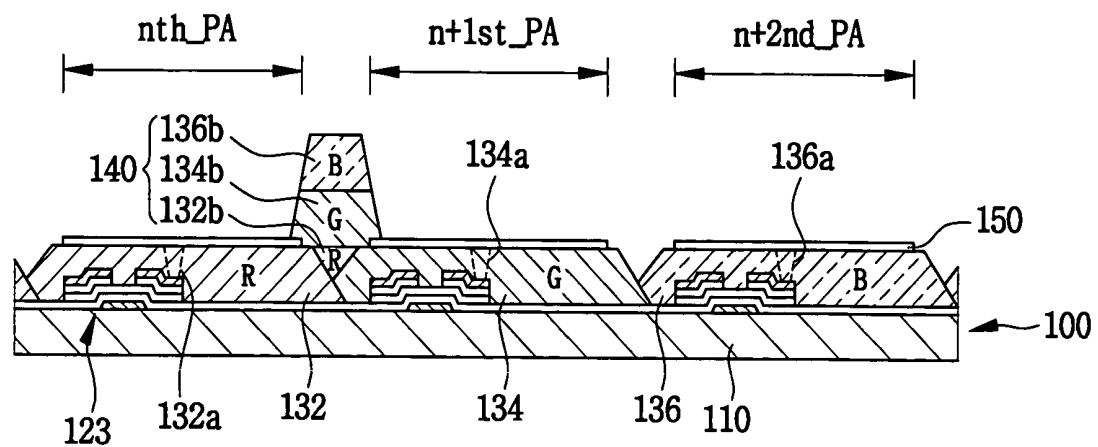

FIG. 23

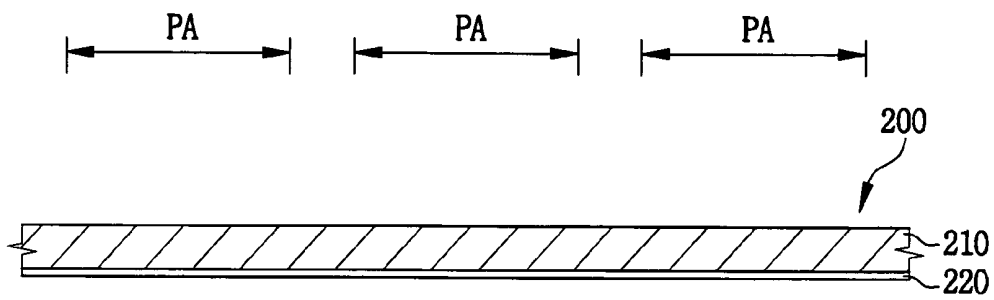

FIG. 24

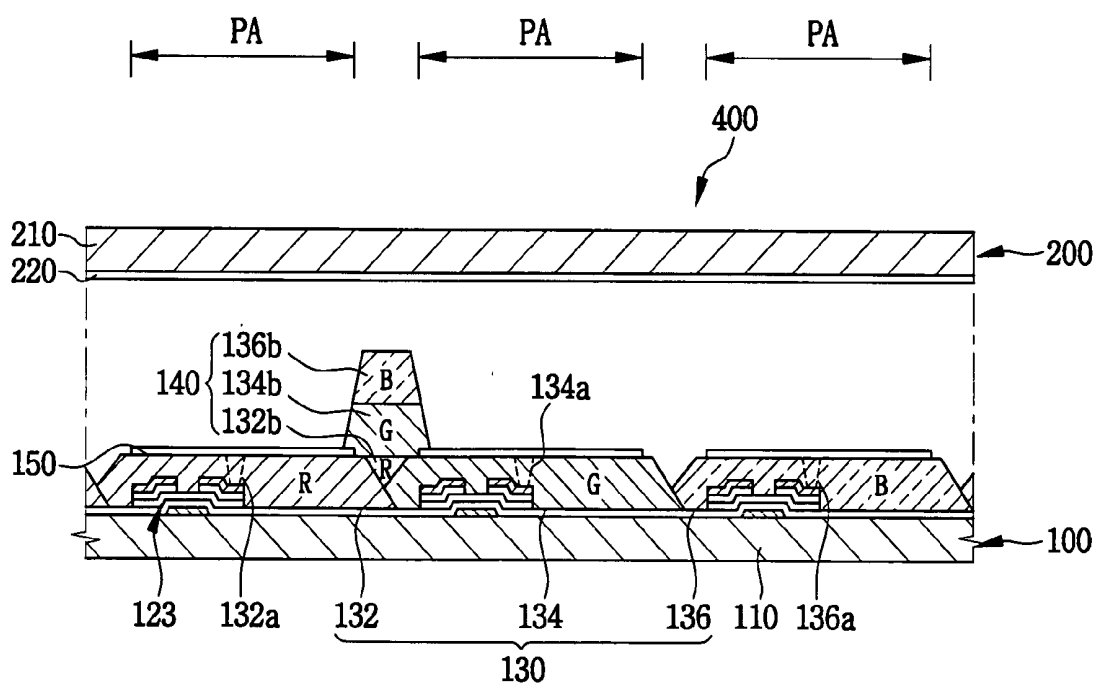

FIG. 25

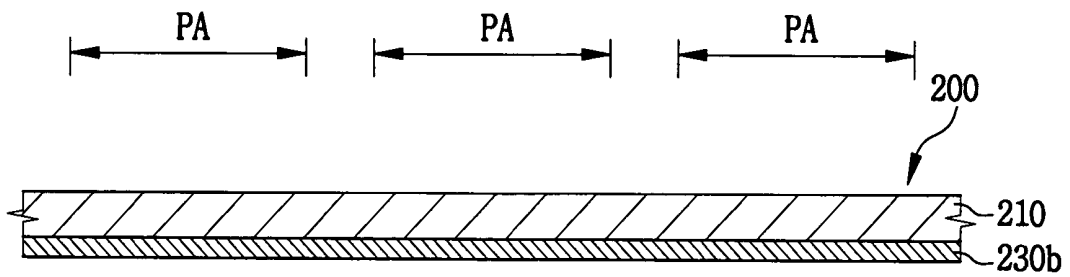

FIG. 26

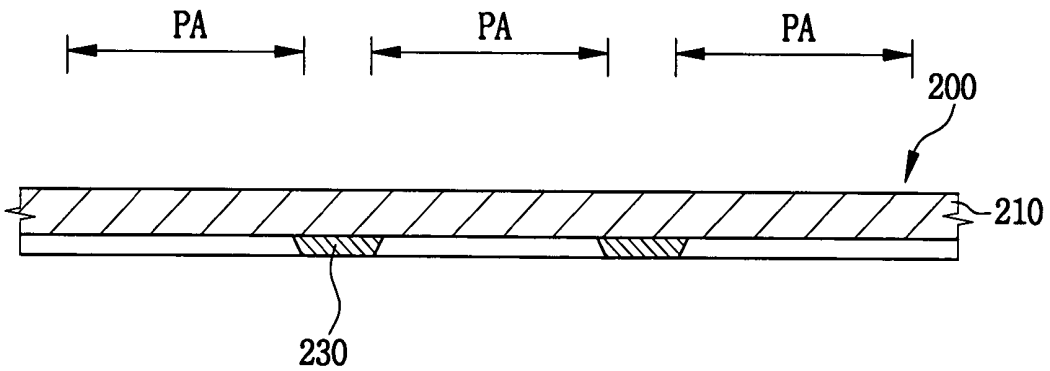

FIG. 27

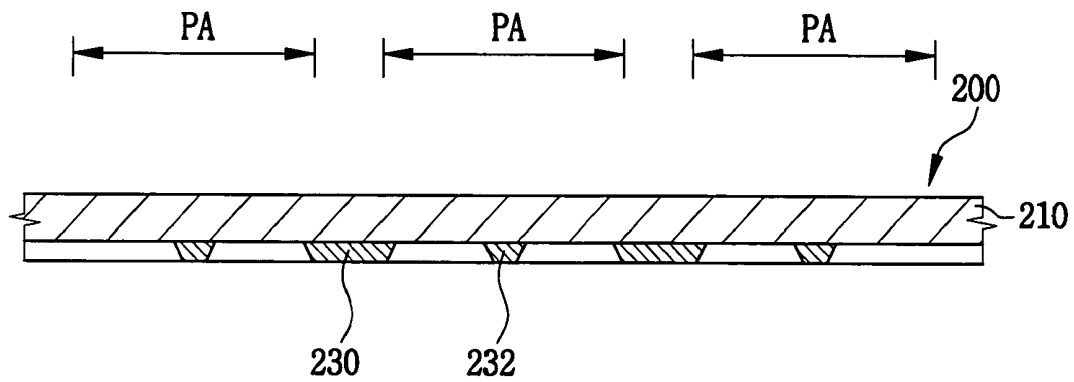

FIG. 28

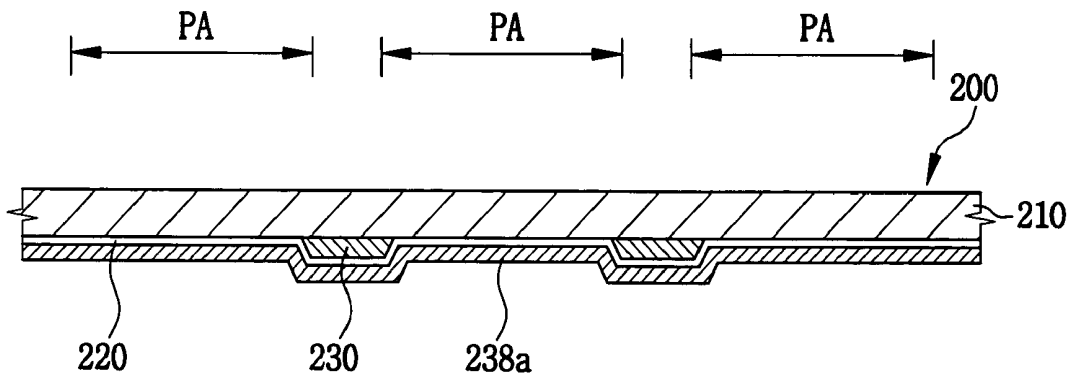

FIG. 29

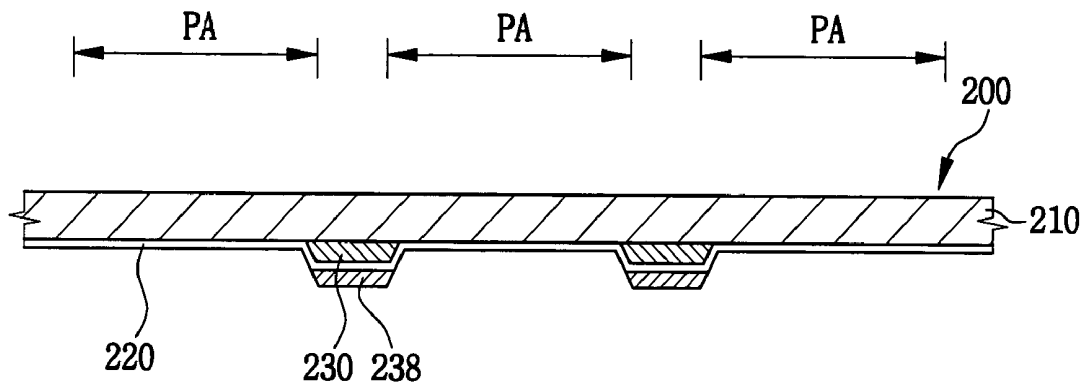

FIG. 30

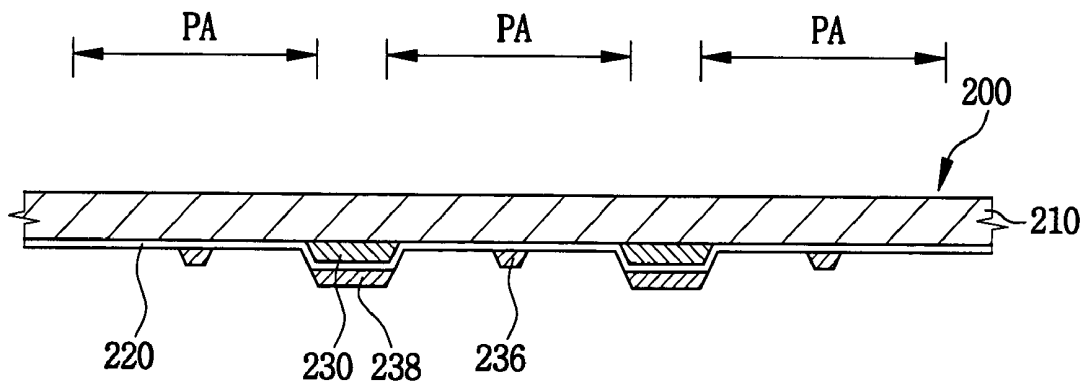

FIG. 31

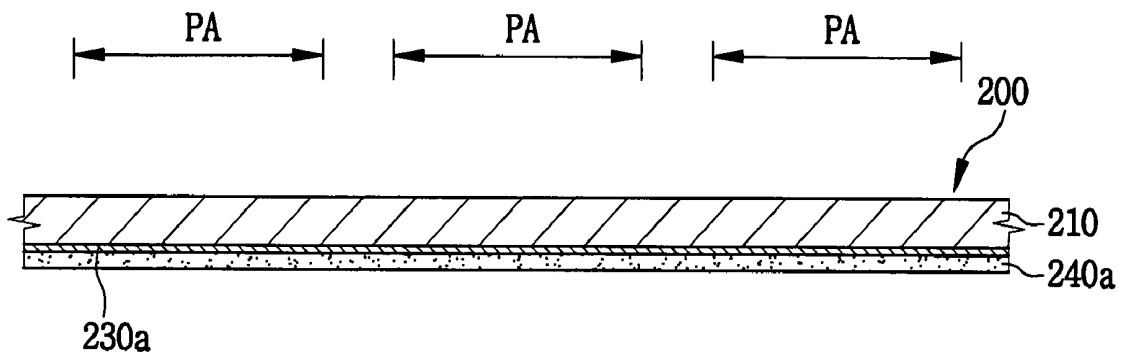

FIG. 32

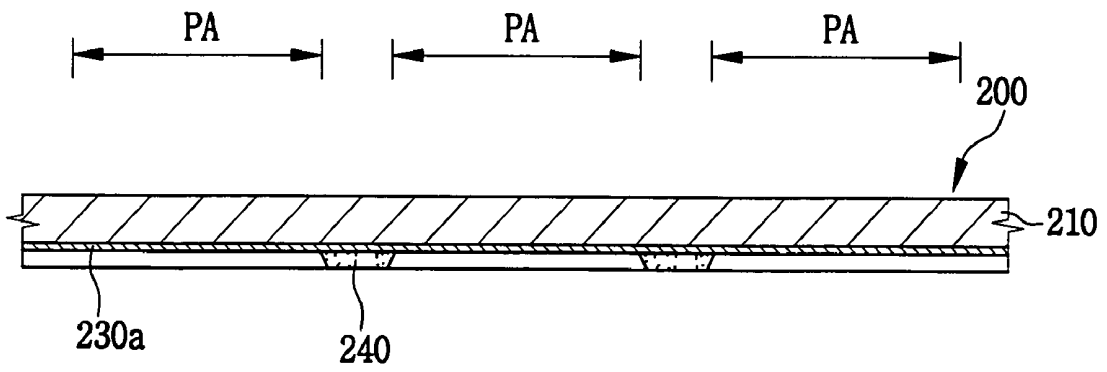

FIG. 33

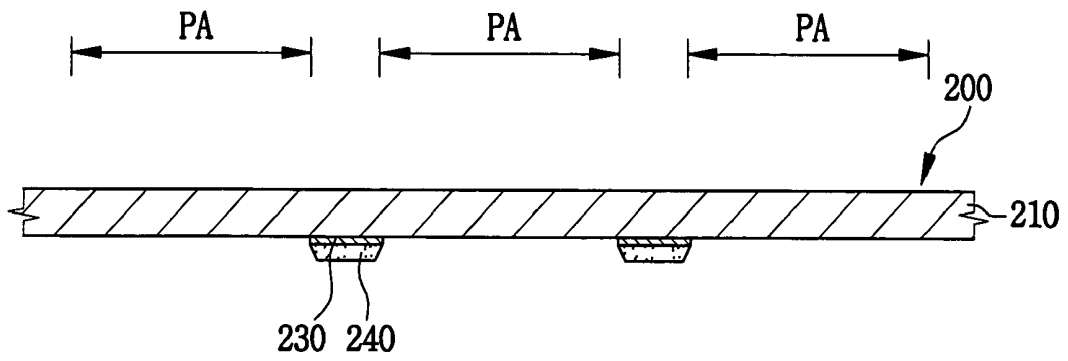

FIG. 34

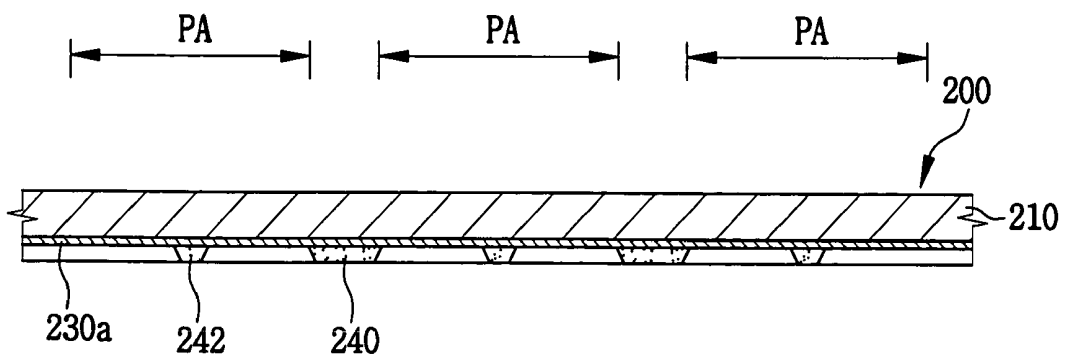

FIG. 35

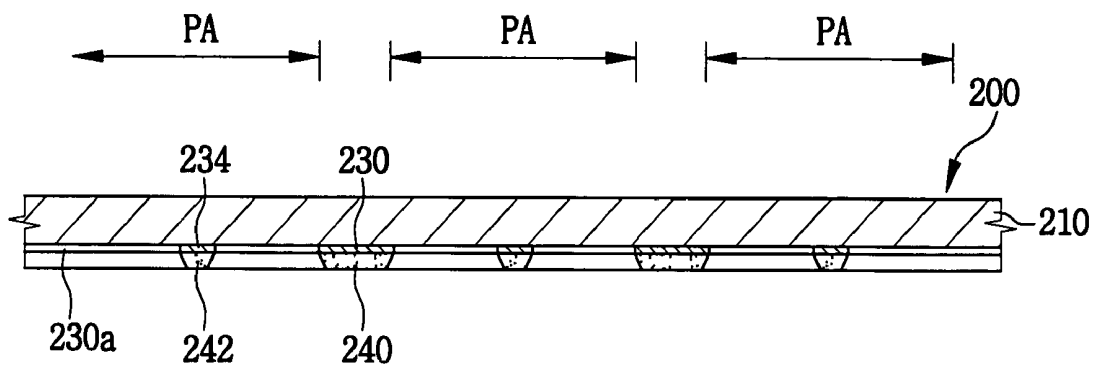

FIG. 36

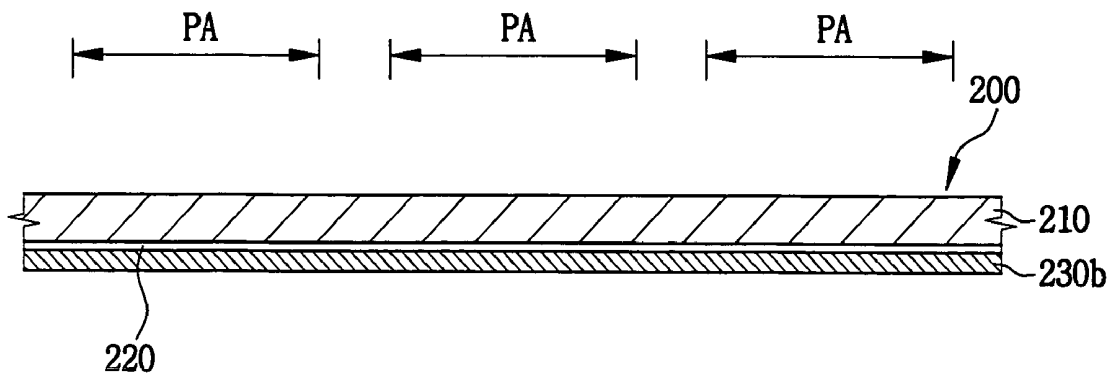

FIG. 37

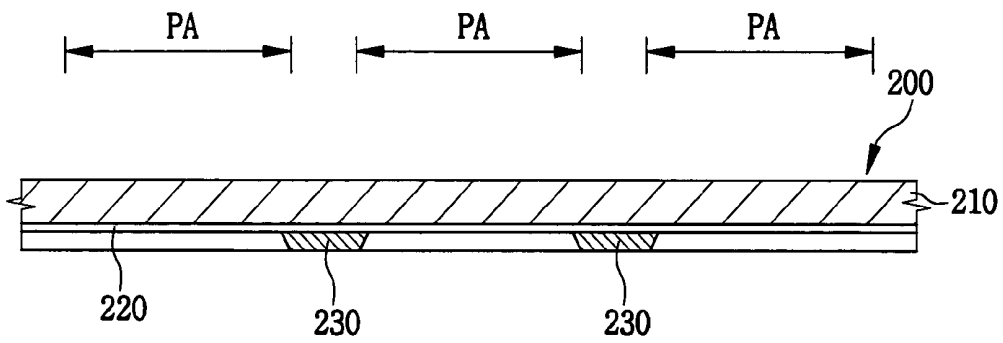

FIG. 38

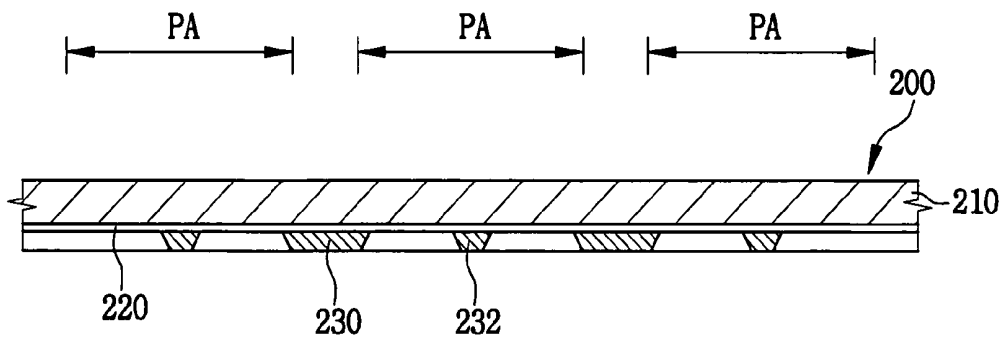

FIG. 39

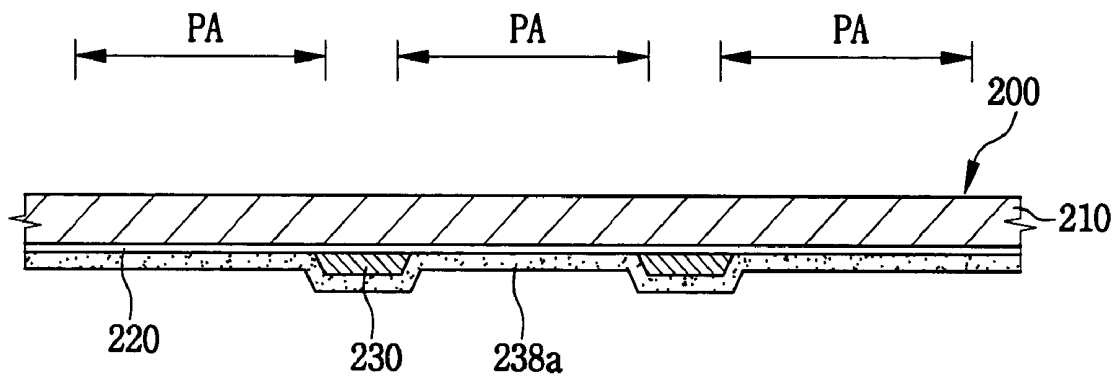

FIG. 40

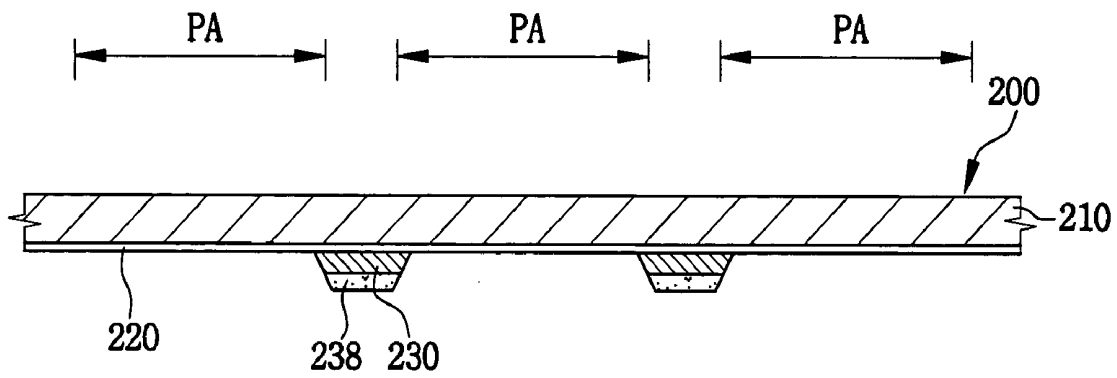

FIG. 41

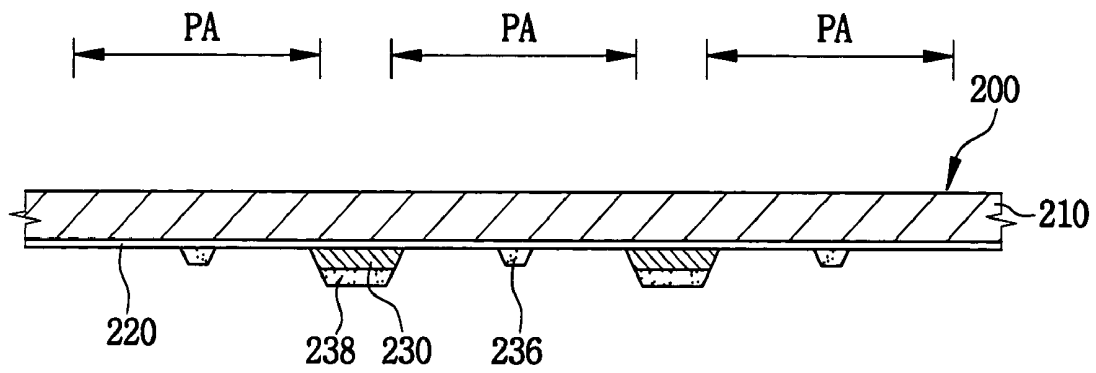

FIG. 42

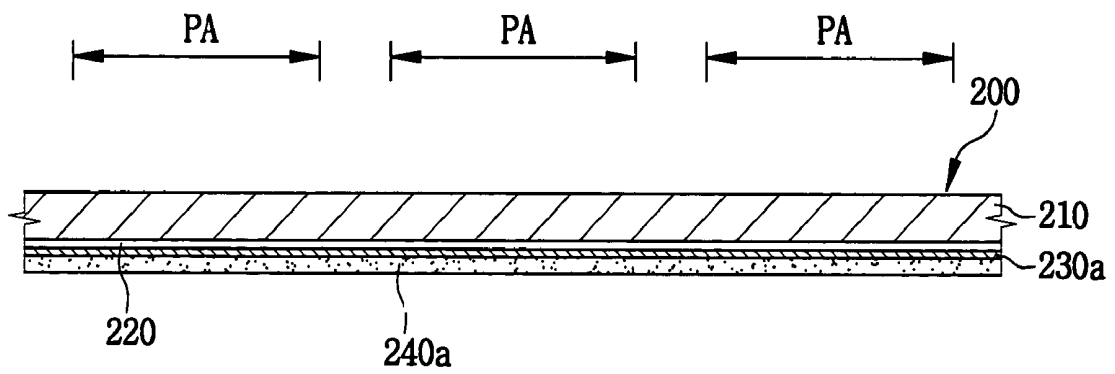

FIG. 43

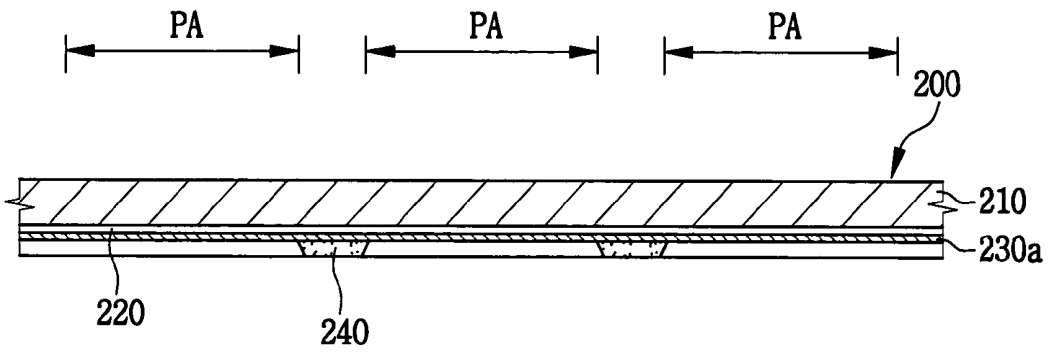

FIG. 44

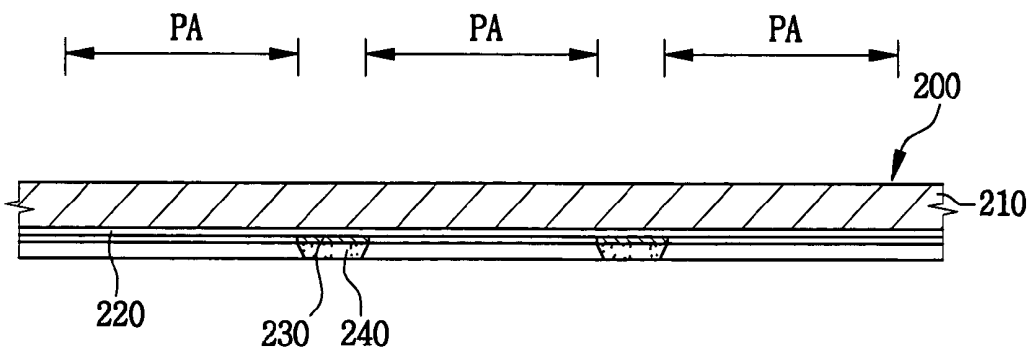

FIG. 45

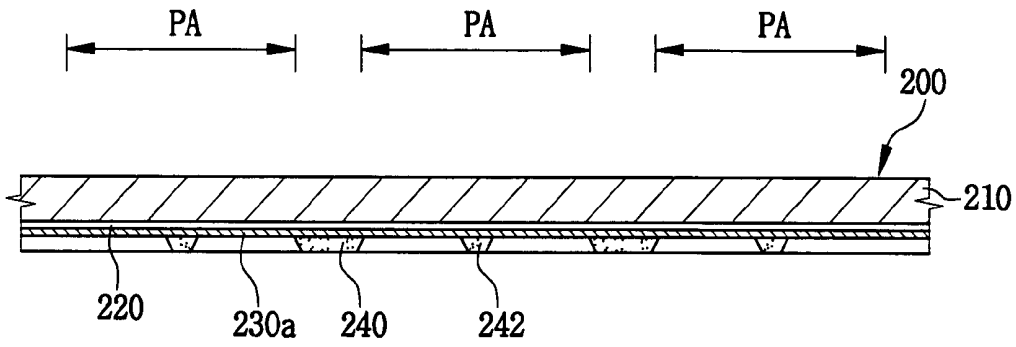
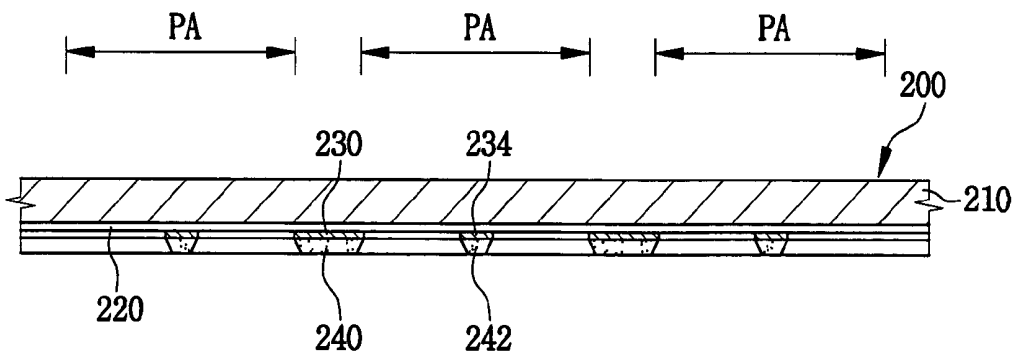

FIG. 46



LIQUID CRYSTAL DISPLAY APPARATUS**CROSS-REFERENCE TO RELATED APPLICATION**

This application relies for priority upon Korean Patent Application No. 2003-37835 filed on Jun. 12, 2003, the contents of which are herein incorporated by reference in its entirety.

BACKGROUND OF THE INVENTION**1. Field of the Invention**

The present invention relates to a liquid crystal display apparatus (LCD) and a method of manufacturing the same, and more particularly to an LCD apparatus having a high display quality and a method of manufacturing the same through simplified and reduced process.

2. Description of the Related Art

An LCD apparatus, generally, displays an image using liquid crystal. In order to display an image, an LCD apparatus includes an LCD panel and a backlight assembly for providing light to the LCD panel. The LCD panel includes a first substrate, a second substrate facing the first substrate and liquid crystal interposed between the first and second substrates.

The first substrate includes a plurality of first electrodes, and the second substrate includes a second electrode facing the first electrodes. Each of the first electrodes receives a different pixel voltage from each other and the second electrode receives a common voltage having a substantially uniform level. The liquid crystal has a light transmittance varied in accordance with an intensity of an electric field applied between the first and second electrodes. That is, the LCD apparatus may display an image by adjusting the light transmittance of the liquid crystal.

In general, a display quality of the LCD apparatus is greatly affected by a cell gap between the first and second substrates. In order to uniformly maintain the cell gap between the first and second substrates, the LCD panel includes a spacer, for example, such as a ball spacer having a spherical shape, a column spacer and so on, disposed between the first and second substrates.

The ball spacer comprising isopropyl alcohol is formed on the first or second substrates through a dispersal process, and the column spacer is also formed on the first or second substrates through a patterning process of a photoresist layer. The first substrate is combined with the second substrate after forming the ball or column spacers.

However, a conventional LCD apparatus needs a lot of processes so as to form the ball or column spacers. As a result, a manufacturing cost of the LCD apparatus may increase.

BRIEF SUMMARY OF THE INVENTION

The present invention provides an LCD apparatus having a high display quality.

The present invention provides a method suitable for manufacturing the above LCD apparatus through simplified and reduced process.

In one aspect of the invention, a liquid crystal display apparatus includes a first panel, a second panel and a liquid crystal layer disposed between the first and second panels.

The first panel includes a first transparent substrate having a pixel area, a thin film transistor disposed at the pixel area so as to output a pixel voltage, a first color filter disposed at the pixel area, the first color filter having a first edge, a second

color filter disposed adjacent to the first color filter and having a second edge, the first edge and the second edge being overlapped to provide an overlapped area between the first color filter and the second color filter, a spacer disposed on the overlapped area between the first color filter and the adjacent second color filter, the spacer having a same material as one of the first color filter and the second color filter, and a pixel electrode disposed on the color filter so as to receive the pixel voltage.

The second panel includes a second transparent substrate and a common electrode disposed on the second transparent substrate.

In another aspect of the invention, a manufacturing method of a liquid crystal display apparatus includes forming a first substrate, forming a second substrate and disposing liquid crystal between the first and second substrates.

The forming of the first substrate includes forming a pixel voltage applying part so as to output a pixel voltage to each pixel area of a first transparent substrate, forming a color filter and a color filter spacer having a same material as the color filter, the color filter corresponding to the pixel area and the color filter spacer being formed at a position corresponding to a space between the pixel area and an adjacent pixel area, and forming a pixel electrode on the color filter to form a first substrate, the pixel electrode receiving the pixel voltage.

The forming of the second substrate includes forming a common electrode, which is facing the pixel electrode, on a second transparent substrate, the second transparent substrate combining with the first transparent substrate.

According to the LCD apparatus and manufacturing method of the LCD apparatus, the first substrate on which the pixel electrode and color filter are formed includes the color filter spacer. The second substrate on which the common electrode is formed includes the light blocking pattern formed at the position between the pixel areas and the light visual angle pattern formed at the position corresponding to the pixel areas. Thus, the LCD apparatus may be manufactured through simplified and reduced processes and improve display quality of an image.

BRIEF DESCRIPTION OF THE DRAWINGS

The above and other advantages of the present invention will become readily apparent by reference to the following detailed description when considered in conjunction with the accompanying drawings wherein:

FIG. 1 is a schematic view showing an LCD apparatus according to a first exemplary embodiment of the present invention;

FIG. 2 is an enlarged view showing a portion "A" of FIG. 1;

FIG. 3 is a cross-sectional view taken along the line III-III' showing the LCD apparatus shown in FIG. 3;

FIG. 4 is a cross-sectional view showing an LCD apparatus according to a second exemplary embodiment of the present invention;

FIG. 5 is a cross-sectional view showing an LCD apparatus according to a third exemplary embodiment of the present invention;

FIG. 6 is a plan view showing a common electrode shown in FIG. 5;

FIG. 7 is a cross-sectional view showing an LCD apparatus according to a fourth exemplary embodiment of the present invention;

FIG. 8 is a cross-sectional view showing an LCD apparatus according to a fifth exemplary embodiment of the present invention;

FIG. 9 is a cross-sectional view showing an LCD apparatus according to a sixth exemplary embodiment of the present invention;

FIG. 10 is a cross-sectional view showing an LCD apparatus according to a seventh exemplary embodiment of the present invention;

FIG. 11 is a cross-sectional view showing an LCD apparatus according to an eighth exemplary embodiment of the present invention;

FIG. 12 is a cross-sectional view showing an LCD apparatus according to a ninth exemplary embodiment of the present invention;

FIG. 13 is a cross-sectional view showing an LCD apparatus according to a tenth exemplary embodiment of the present invention;

FIG. 14 is a cross-sectional view showing an LCD apparatus according to an eleventh exemplary embodiment of the present invention;

FIG. 15 is a cross-sectional view showing an LCD apparatus according to a twelfth exemplary embodiment of the present invention;

FIG. 16 is a cross-sectional view showing an LCD apparatus according to a thirteenth exemplary embodiment of the present invention;

FIG. 17 is a cross-sectional view showing an LCD apparatus according to a fourteenth exemplary embodiment of the present invention;

FIG. 18A is a cross-sectional view showing a first substrate having a driving voltage applying device according to a fifteenth exemplary embodiment of the present invention;

FIG. 18B is a schematic circuit diagram showing a driving voltage applying device;

FIG. 19 is a cross-sectional view showing a red color filter formed at pixel areas and a red color filter spacer formed between pixel areas shown in FIG. 19;

FIG. 20 is a cross-sectional view showing a green color filter formed at pixel areas and a green color filter spacer formed between pixel areas shown in FIG. 18;

FIG. 21 is a cross-sectional view showing a blue color filter formed at pixel areas and a blue color filter spacer formed between pixel areas shown in FIG. 18;

FIG. 22 is a cross-sectional view showing a pixel electrode formed on the color filter shown in FIG. 21;

FIG. 23 is a cross-sectional view showing a second substrate of an LCD apparatus according to the fifteenth exemplary embodiment of the present invention;

FIG. 24 is a cross-sectional view showing a first substrate assembled with a second substrate of an LCD apparatus according to the fifteenth exemplary embodiment of the present invention;

FIGS. 25 and 26 are cross-sectional views showing a second substrate according to a sixteenth exemplary embodiment of the present invention;

FIG. 27 is a cross-sectional view showing a second substrate according to a seventeenth exemplary embodiment of the present invention;

FIGS. 28 and 29 are cross-sectional views showing a second substrate according to an eighteenth exemplary embodiment of the present invention;

FIG. 30 is a cross-sectional view showing a second substrate according to a nineteenth exemplary embodiment of the present invention;

FIGS. 31 to 33 are cross-sectional views showing a second substrate according to a twentieth exemplary embodiment of the present invention;

FIGS. 34 and 35 are cross-sectional views showing a second substrate according to a twenty-first exemplary embodiment of the present invention;

FIGS. 36 and 37 are cross-sectional views showing a second substrate according to a twenty-second exemplary embodiment of the present invention;

FIG. 38 is a cross-sectional view showing a second substrate according to a twenty-third exemplary embodiment of the present invention;

FIGS. 39 and 40 are cross-sectional views showing a second substrate according to a twenty-fourth exemplary embodiment of the present invention;

FIG. 41 is cross-sectional view showing a second substrate according to a twenty-fifth exemplary embodiment of the present invention;

FIGS. 42 to 44 are cross-sectional views showing a second substrate according to a twenty-sixth exemplary embodiment of the present invention; and

FIGS. 45 and 46 are cross-sectional views showing a second substrate according to a twenty-seventh exemplary embodiment of the present invention.

DETAILED DESCRIPTION OF THE INVENTION

Embodiments of an LCD Apparatus

Embodiment 1

FIG. 1 is a schematic view showing an LCD apparatus according to a first exemplary embodiment of the present invention. FIG. 2 is an enlarged view showing a portion "A" of FIG. 1. FIG. 3 is a cross-sectional view taken along the line III-III' showing the LCD apparatus shown in FIG. 3.

Referring to FIGS. 1 to 3, an LCD apparatus 400 includes a first substrate or panel 100, a second substrate or panel 200 and liquid crystal layer 300.

The first substrate or panel 100 includes a first transparent substrate 110, a driving voltage-applying device 120, a color filter 130, a color filter spacer 140 and a pixel electrode 150.

The first transparent substrate 110 comprises a glass substrate having a high light transmittance and a plurality of pixel areas 101 (refer to FIG. 2). In case that the LCD apparatus has a resolution of 1024×768, the first transparent substrate 110 includes the pixel areas of 1024×768×3 units. The light passing through the pixel areas is exited in mosaic, and thus user may recognize the image.

The driving voltage applying device 120 disposed at each pixel areas 101 includes a gate bus line 121, a data bus line 122 and a thin film transistor (TFT) 123.

The gate bus line 121 is extended in a first direction D1 and the data bus line 122 is extended in a second direction D2 substantially perpendicular to the first direction D1. When the resolution of the LCD apparatus 400 is 1024×768, the gate bus line 121 of 768 units is formed on the first transparent substrate 110 and the data bus line 122 of 1024×3 units is formed on the first transparent substrate 110.

The TFT 123 is formed at each pixel areas 101 of the first transparent substrate 110. Particularly, the TFT 123 is disposed at a position where the gate and data bus lines 121 and 122 are intersected with each other. The TFT 123 includes a gate electrode portion G, a channel layer C, a source electrode portion S and a drain electrode portion D. The gate electrode portion G is extended from the gate bus line 121 in the second direction D2. The channel layer C is insulated from the gate electrode portion G and disposed on the gate electrode portion G. The channel layer C includes an amorphous silicon film and an n⁺ amorphous silicon film disposed on the amor-

phous silicon film. The n⁺ amorphous silicon film disposed on the amorphous silicon film is divided into two portions. The source electrode portion S is extended from the data bus line 122 to the pixel areas 101. The source electrode portion S makes contact with one of two portions of the n⁺ amorphous silicon film, and the drain electrode portion D makes contact with a remained one of two portion of the n⁺ amorphous silicon film.

As shown in FIG. 3, the color filter 130 is disposed at each pixel areas 101. The edge of the color filter 130 is overlapped with an edge of an adjacent color filter 130 at a position between the pixel areas 101. The overlapped area of the color filter 130 blocks light leaked through between the pixel areas 101. Thus, the LCD apparatus 400 does not need a light blocking pattern, for example, such as a black matrix pattern, for blocking the light leaked through between the pixel areas 101.

The color filter 130 includes a red (R) color filter 132, a green (G) color filter 134 and a blue (B) color filter 136. The R color filter 132 includes an R color filter material that transmits an R wavelength, the G color filter 134 includes a G color filter material that transmits a G wavelength, and the B color filter material that transmits a B wavelength. In the pixel areas 101, an Nth pixel area includes the R color filter 132, an N+1st pixel area includes the G color filter 134, and N+2nd pixel area includes a B color filter 136. The color filter 130 covers the TFT 123. The R, G and B color filters 132, 134 and 136 include contact holes 132a, 134a and 136a so as to partially expose the drain electrode portion D.

The color filter spacer 140 is disposed between the pixel areas 101 formed on the first transparent substrate 110, and comprises a same material as the color filter 130. The color filter spacer 140 includes an R color filter spacer 132b, a G color filter spacer 134b and a B color filter spacer 136b. The R, G and B color filter spacers 132b, 134b and 146b comprise an R color filter material, a G color filter material and a B color filter material, respectively. At least one of the R, G and B color filter spacers 132b, 134b and 136b has a column shape. The color filter spacer 140 having the column shape is disposed between the first and second substrates 100 and 200 so as to maintain the cell gap between the first and second substrates 100 and 200. In order to uniformly maintain the cell gap, the color filter spacer 140 may be formed at each pixel areas 101.

The pixel electrode 150 is formed at the pixel areas 101, and disposed on the color filter 130. The pixel electrode 150 includes a transparent and conductive material, for example, such as indium tin oxide (ITO), indium zinc oxide (IZO) or the like. The pixel electrode 150 is electrically connected to the drain electrode portion D of a corresponding TFT 123 through the contact holes 132a, 134a and 136a. Also, the pixel electrode 150 receives a driving voltage from the TFT 123.

Referring to FIG. 3, the second substrate or panel 200 includes a second transparent substrate 210 and a common electrode 220. The common electrode 220 is formed over the second transparent substrate 210, which comprises the ITO or IZO.

The first substrate 100 is assembled with the second substrate 200 such that the pixel electrode 150 faces the common electrode 220. In order to assemble the first substrate 100 with the second substrate 200, the first and second substrates 100 and 200 include a sealing member 115 (refer to FIG. 1). The sealing member 115 has a band shape, and is formed on edges of the first and second substrates 100 and 200.

The liquid crystal 300 is disposed between the first and second substrates 100 and 200. The liquid crystal 300 varies

an arrangement thereof in accordance with an electric field between the pixel and common electrodes 150 and 220.

In this exemplary embodiment, the LCD apparatus 400 may further include a backlight assembly (not shown) disposed adjacent to the first substrate 100 so as to supply the light to the liquid crystal 300. Also, the LCD apparatus 400 may further include an optical sheet, for example, such as a diffusion sheet, a prism sheet, etc., disposed between the first substrate 100 and backlight assembly so as to improve optical properties of the light provided from the backlight assembly.

In this exemplary embodiment, the first transparent substrate 110 includes the TFT 123 disposed at each pixel areas 101, color filter 130 formed over the TFT 123, pixel electrode 150 formed on the color filter 130, and color filter spacer 140 comprising same material as the color filter 130. Since the color filter spacer 140 is substantially and simultaneously formed with the color filter 130, the LCD apparatus 400 does not need separate processes for forming the color filter spacer 140. Thus, the LCD apparatus 400 may be manufactured through simplified and reduced process.

Embodiment 2

FIG. 4 is a cross-sectional view showing an LCD apparatus according to a second exemplary embodiment of the present invention. In FIG. 4, the same reference numerals denote the same elements in FIGS. 1 to 3, and thus the detailed descriptions of the same elements will be omitted.

Referring to FIG. 4, a second substrate 200 further includes a light blocking pattern 230 formed on a common electrode 220. The light blocking pattern 230 is formed by patterning a light blocking layer that comprises an organic material having a light transmittance or a light blocking rate substantially equal to that of a chromium Cr. The light blocking layer may comprise a black-colored organic material having the light transmittance or the light blocking rate substantially equal to that of a chromium Cr. The light blocking pattern 230 having a lattice-shape transmits the light incident through an opening 230a corresponding to the pixel areas 101 and blocks the light incident through between the pixel areas 101, thereby improving a display quality. The light blocking pattern 230 has a lower surface making contact with an upper surface of the color filter spacer 140.

A liquid crystal having liquid crystal molecules vertically aligned or a twist nematic liquid crystal may be disposed between the first and second substrates 100 and 200. In this exemplary embodiment, the twist nematic liquid crystal is disposed between the first and second substrates 100 and 200.

According to this exemplary embodiment, the light blocking pattern 230 formed on the common electrode 220 makes contact with the upper surface of the color filter spacer 140 to block the light leaked through between the pixel areas 101. Thus, the LCD apparatus 400 may be manufactured through simplified and reduced process.

Embodiment 3

FIG. 5 is a cross-sectional view showing an LCD apparatus according to a third exemplary embodiment of the present invention. FIG. 6 is a plan view showing a common electrode shown in FIG. 5. In FIGS. 5 and 6, the same reference numerals denote the same elements in FIG. 4, and thus the detailed descriptions of the same elements will be omitted.

Referring to FIGS. 5 and 6, a second substrate 200 further includes a light blocking pattern 230 formed on a common electrode 220 and a light visual angle pattern 232.

The light blocking pattern **230** is formed by patterning a light blocking layer that comprises an organic material having a light transmittance or a light blocking rate substantially equal to that of a chromium Cr. The light blocking pattern **230** has an opening **230a** corresponding to pixel areas **101**. The light blocking pattern **230** having a lattice-shape transmits the light incident into the pixel areas **101**, and blocks the light incident through between the pixel areas **101**. The light blocking pattern **230** has a lower surface making contact with an upper surface of the color filter spacer **140**.

The light visual angle pattern **232** is formed on the common electrode **220** and disposed between the light blocking pattern **230** and an adjacent light blocking pattern **230**. The light visual angle pattern **232** has a band shape, and varies arrangement of liquid crystal **300**, thereby widening a visual angle of an image.

In order to widen the visual angle of the image using the light visual angle pattern **232**, a liquid crystal having liquid crystal molecules vertically aligned may be disposed between the first and second substrates **100** and **200**.

In this exemplary embodiment, the light blocking layer is patterned to substantially and simultaneously form the light blocking pattern **220** that blocks the light leaked through between the pixel areas **101** and the light visual angle pattern **232**. Thus, the LCD apparatus **400** may have an improved display quality by widening the visual angle of the image. Also, the LCD apparatus **400** also may be manufactured through simplified and reduced process.

Embodiment 4

FIG. 7 is a cross-sectional view showing an LCD apparatus according to a fourth exemplary embodiment of the present invention. In FIG. 7, the same reference numerals denote the same elements in FIG. 4, and thus the detailed descriptions of the same elements will be omitted.

Referring to FIG. 7, a light blocking layer having a light transmittance or a light blocking rate substantially equal to that of a chromium Cr is formed on a second transparent substrate **210** of a second substrate **200**. The light blocking layer is patterned to form a light blocking pattern **230** having an opening **230a** on the second transparent substrate **210**, which is corresponding to pixel areas **101**.

A common electrode **220** comprising ITO or IZO is formed over the second transparent substrate **210** on which the light blocking pattern **230** is formed. The common electrode **220** directly makes contact with a color spacer **140** formed on a first substrate **100**.

The common electrode **220** reinforces the light blocking pattern **230** comprising an organic material, thereby preventing the light blocking pattern **230** from being damaged due to an impact externally provided. Thus, a cell gap between the first and second substrates **100** and **200** may be uniformly maintained.

In this exemplary embodiment, the light blocking pattern **230** and common electrode **220** are successively formed on the second transparent substrate **210**. Thus, an LCD apparatus **400** may block the light leaked through between the pixel areas **101**, so that the LCD apparatus **400** may be manufactured through simplified and reduced process. The LCD apparatus **400** may also prevent the light blocking pattern **230** from being damaged due to an impact externally provided using the common electrode **220**, thereby improving a display quality thereof.

Embodiment 5

FIG. 8 is a cross-sectional view showing an LCD apparatus according to a fifth exemplary embodiment of the present

invention. In FIG. 8, the same reference numerals denote the same elements in FIG. 7, and thus the detailed descriptions of the same elements will be omitted.

Referring to FIG. 8, a second substrate **200** includes a light blocking pattern **230** and a light visual angle pattern **232** formed on a second transparent substrate **210**. The light blocking pattern **230** and light visual angle pattern **232** are disposed between the second transparent substrate **210** and a common electrode **220**.

The light blocking pattern **230** is formed by patterning a light blocking layer that comprises an organic material having a light transmittance or a light blocking rate substantially equal to that of a chromium Cr. The light blocking pattern **230** has an opening **230a** corresponding to pixel areas **101**. The light blocking pattern **230** having a lattice-shape transmits the light incident into the pixel areas **101** and blocks the light incident through between the pixel areas **101**.

The light visual angle pattern **232** is formed between the second transparent substrate **210** and common electrode **220**, and disposed between the light blocking pattern **230** and an adjacent light blocking pattern **230**. The light visual angle pattern **232** having a line shape is simultaneously formed with the light blocking pattern **230** by patterning the light blocking layer.

In order to widen a visual angle of an image using the light visual angle pattern **232**, a liquid crystal having liquid crystal molecules vertically aligned may be disposed between the first and second substrates **100** and **200**.

The common electrode **220** is formed on the second transparent substrate **210** such that the light blocking pattern **230** and light visual angle pattern **232** are covered by means of the common electrode **220**. Thus, the common electrode **220** makes contact with an upper surface of a color filter spacer **140** formed on the first substrate **100**.

In this exemplary embodiment, the light blocking layer is patterned to substantially and simultaneously form the light blocking pattern **220** and light visual angle pattern **232**. Thus, the LCD apparatus **400** also may be manufactured through simplified and reduced process. The LCD apparatus **400** may also prevent the light blocking pattern **230** from being damaged due to an impact externally provided using the common electrode **220**, thereby improving a display quality thereof.

Embodiment 6

FIG. 9 is a cross-sectional view showing an LCD apparatus according to a sixth exemplary embodiment of the present invention. In FIG. 9, the same reference numerals denote the same elements in FIG. 4, and thus the detailed descriptions of the same elements will be omitted.

Referring to FIG. 9, a light blocking layer comprising chromium Cr or a double-layer light blocking layer comprising chromium Cr and chromium oxide CrO₂ is formed on a common electrode **220** of a second substrate **200**. In this exemplary embodiment, the light blocking layer comprises the chromium Cr. The light blocking layer comprising the chromium Cr or a double-layer light blocking layer comprising chromium Cr and chromium oxide CrO₂ has a thickness thinner than and a strength stronger than those of a light blocking layer comprising an organic material.

A photosensitive layer comprising a photosensitive material is formed over the light blocking layer. The photosensitive layer is patterned to form a photosensitive pattern **240** on the light blocking layer.

When the light blocking layer is patterned using the photosensitive pattern **240** as a mask, a light blocking pattern **230** is formed at a position between pixel areas **101**, so that the

light blocking pattern 230 and photosensitive pattern 240 are formed on the common electrode 220. The photosensitive pattern 240 makes contact with an upper surface of a color filter spacer 140 formed on a first substrate 100.

In this exemplary embodiment, the light blocking pattern 230 and photosensitive pattern 240 are successively formed on the common electrode 220, and disposed between the pixel areas 101. When the color filter spacer 140 has a height lower than that of a cell gap between the first and second substrates 100 and 200, the light blocking pattern 230 and photosensitive pattern 240 may uniformly maintain the cell gap between the first and second substrates 100 and 200 with the color filter spacer 140, thereby preventing variation of the cell gap of an LCD apparatus 400.

Embodiment 7

FIG. 10 is a cross-sectional view showing an LCD apparatus according to a seventh exemplary embodiment of the present invention. In FIG. 10, the same reference numerals denote the same elements in FIG. 9, and thus the detailed descriptions of the same elements will be omitted.

Referring to FIG. 10, a light blocking layer comprising chromium Cr or a double-layer light blocking layer comprising chromium Cr and chromium oxide CrO₂ is formed on a common electrode 220 of a second substrate 200. In this exemplary embodiment, the light blocking layer comprises the chromium Cr.

A photosensitive layer comprising a photosensitive material is formed over the light blocking layer. The photosensitive layer is patterned to form a first light visual angle pattern 242 and a photosensitive pattern 240 on the light blocking layer. The first light visual angle pattern 242 having a line shape is formed at a position corresponding to pixel areas 101. The photosensitive pattern 240 is formed at a position between the pixel areas 101.

When the light blocking layer is patterned using the photosensitive pattern 240 and first visual angle pattern 242 as a mask, a second visual angle pattern 234 and a light blocking pattern 230 are formed under the first visual angle pattern 242 and photosensitive pattern 234, respectively. The photosensitive pattern 240 makes contact with an upper surface of a color filter spacer 140 formed on a first substrate 100. Liquid crystal having liquid crystal molecules vertically aligned is disposed between the first and second substrates 100 and 200.

In this exemplary embodiment, the light blocking pattern 230 and photosensitive pattern 240 are successively formed on the common electrode 220 corresponding to the position between the pixel areas 101. Also, the second light visual angle pattern 234 and first light visual angle pattern 242 are successively formed on the common electrode 220 corresponding to the pixel areas 101. Thus, the LCD apparatus 400 may prevent leakage of the light through between the pixel areas 101, and may widen the visual angle of the image, thereby improving a display quality.

Embodiment 8

FIG. 11 is a cross-sectional view showing an LCD apparatus according to an eighth exemplary embodiment of the present invention. In FIG. 11, the same reference numerals denote the same elements in FIG. 9, and thus the detailed descriptions of the same elements will be omitted.

Referring to FIG. 11, a light blocking layer comprising chromium Cr or a double-layer light blocking layer comprising chromium Cr and chromium oxide CrO₂ is formed on a

common electrode 210 of a second substrate 200. In this exemplary embodiment, the light blocking layer comprises the chromium Cr.

A photosensitive layer comprising a photosensitive material is formed over the light blocking layer. The photosensitive layer is patterned to form a photosensitive pattern 240 on the light blocking layer.

When the light blocking layer is patterned using the photosensitive pattern 240 as a mask, a light blocking pattern 230 is formed at a position between pixel areas 101, so that the light blocking pattern 230 and photosensitive pattern 240 are formed on a second transparent substrate 210. A common electrode 220 is formed over the second transparent substrate 210 so as to allow the light blocking pattern 230 and photosensitive pattern 240 to be covered thereby. Also, the common electrode 220 makes contact with an upper surface of a color filter spacer 140 formed on a first substrate 100.

In this exemplary embodiment, the light blocking pattern 230 and photosensitive pattern 240 are successively formed on the second transparent substrate 210 and disposed between the pixel areas 101. The common electrode 220 is formed on the photosensitive pattern 240 and second transparent substrate 210. When the color filter spacer 140 has a height lower than that of a cell gap between the first and second substrates 100 and 200, the light blocking pattern 230 and photosensitive pattern 240 may uniformly maintain the cell gap between the first and second substrates 100 and 200 with the color filter spacer 140, thereby preventing variation of the cell gap of an LCD apparatus 400.

Embodiment 9

FIG. 12 is a cross-sectional view showing an LCD apparatus according to a ninth exemplary embodiment of the present invention. In FIG. 12, the same reference numerals denote the same elements in FIG. 10, and thus the detailed descriptions of the same elements will be omitted.

Referring to FIG. 12, a light blocking layer comprising chromium Cr or a double-layer light blocking layer comprising chromium Cr and chromium oxide CrO₂ is formed on a second transparent substrate 210 of a second substrate 200. In this exemplary embodiment, the light blocking layer comprises the chromium Cr.

A photosensitive layer comprising a photosensitive material is formed over the light blocking layer. The photosensitive layer is patterned to form a first light visual angle pattern 242 and a photosensitive pattern 240 on the light blocking layer. The first light visual angle pattern 242 having a line shape is formed at a position corresponding to pixel areas 101. The photosensitive pattern 240 is formed at a position between the pixel areas 101.

When the light blocking layer is patterned using the photosensitive pattern 240 and first visual angle pattern 242 as a mask, a second visual angle pattern 234 and a light blocking pattern 230 are formed under the first visual angle pattern 242 and photosensitive pattern 234, respectively.

A common electrode 220 is formed over the second transparent substrate 210 so as to allow the light blocking pattern 230 and photosensitive pattern 240 to be covered thereby. Also, the common electrode 220 makes contact with an upper surface of a color filter spacer 140 formed on a first substrate 100.

In this exemplary embodiment, the light blocking pattern 230 and photosensitive pattern 240 are successively formed on the second transparent substrate 210 corresponding to the position between the pixel areas 101. Also, the second light visual angle pattern 234 and first light visual angle pattern 242

are successively formed on the second transparent substrate **210** corresponding to the pixel areas **101**. Thus, the LCD apparatus **400** may prevent leakage of the light through between the pixel areas **101** and may widen the visual angle of the image, thereby improving a display quality.

Embodiment 10

FIG. **13** is a cross-sectional view showing an LCD apparatus according to a tenth exemplary embodiment of the present invention. In FIG. **13**, the same reference numerals denote the same elements in FIG. **7**, and thus the detailed descriptions of the same elements will be omitted.

Referring to FIG. **13**, a common electrode **220** is formed over a second transparent substrate **210** such that a light blocking pattern **230** formed on the second transparent substrate **210** of a second substrate **200** is covered by the common electrode **220**. A light visual angle pattern **236** is formed on the common electrode **220** corresponding to pixel areas **101** so as to widen a visual angle of an image. In order to prevent decrease of brightness needed to display the image, the light visual angle pattern **236** may comprise a transparent organic material. Liquid crystal having liquid crystal molecules vertically aligned is disposed between the second substrate **200** and a first substrate **100** facing the second substrate **200**.

In this exemplary embodiment, the light blocking pattern **230** is formed on the second transparent substrate **210** so as to block the light leaked through between the pixel areas **101**. Also, the light visual angle pattern **236** having the transparent organic material is formed on the common electrode **220** corresponding to the pixel areas **101**. Thus, the LCD apparatus **400** may improve display quality thereof.

Embodiment 11

FIG. **14** is a cross-sectional view showing an LCD apparatus according to an eleventh exemplary embodiment of the present invention. In FIG. **14**, the same reference numerals denote the same elements in FIG. **13**, and thus the detailed descriptions of the same elements will be omitted.

Referring to FIG. **14**, a transparent spacer **238** is formed at a position corresponding to a light blocking pattern **230** disposed at a position between pixel areas **101**. A common electrode **220** formed over a second transparent substrate **210** is disposed between the light blocking pattern **230** and transparent spacer **238**. A transparent light visual angle pattern **236** is formed on the second transparent substrate **210** corresponding to the pixel areas **101**. In the pixel areas **101**, the common electrode **220** is also disposed between the second transparent substrate **210** and light visual angle pattern **236**. The transparent spacer **238** and transparent light visual angle pattern **236** are substantially and simultaneously formed by patterning a transparent organic layer formed on the common electrode **220**.

In this exemplary embodiment, when the color filter spacer **140** has a height lower than that of a cell gap between the first and second substrates **100** and **200**, the transparent spacer **238** may uniformly maintain the cell gap between the first and second substrates **100** and **200** with the color filter spacer **140**, thereby preventing variation of the cell gap of an LCD apparatus **400**. The light blocking pattern **230** may block the light incident into between the pixel areas **101** and the light visual angle pattern **236** may widen a visual angle of an image. Thus, an LCD apparatus **400** may improve display quality thereof.

Embodiment 12

FIG. **15** is a cross-sectional view showing an LCD apparatus according to a twelfth exemplary embodiment of the

present invention. In FIG. **15**, the same reference numerals denote the same elements in FIGS. **1** to **3**, and thus the detailed descriptions of the same elements will be omitted.

Referring to FIG. **15**, in case that a cell gap between first and second substrates **100** and **200** is substantially equal to a height of a color filter spacer **140**, a light visual angle pattern **250** is formed on a common electrode **220** formed on a second transparent substrate **210**. The light visual angle pattern **250** is disposed at a position corresponding to pixel areas **101**. In order to form the light visual angle pattern **250**, a transparent organic layer is formed on the common electrode **220**, and patterned through a patterning process. The light visual angle pattern **250** varies arrangement of liquid crystal **300** disposed between the first and second substrates **100** and **200** so as to widen a visual angle of an image. The liquid crystal **300** has liquid crystal molecules vertically aligned.

In this exemplary embodiment, the light visual angle pattern **250** comprising a transparent organic material is formed on the second transparent **200**, which is corresponding to the pixel areas **101**. Thus, an LCD apparatus **400** may widen the visual angle of the image displayed thereon without decrease of brightness of the light passing through the pixel areas **101**.

Embodiment 13

FIG. **16** is a cross-sectional view showing an LCD apparatus according to a thirteenth exemplary embodiment of the present invention. In FIG. **16**, the same reference numerals denote the same elements in FIGS. **1** to **3**, and thus the detailed descriptions of the same elements will be omitted.

Referring to FIG. **16**, in case that a cell gap between first and second substrates **100** and **200** is higher than a height of a color filter spacer **140** formed on the first substrate **100**, a transparent spacer **252** is further formed on a common electrode **220** that is formed on a second transparent substrate **210**. The transparent spacer **252** is disposed at a position between pixel areas **101**. The transparent spacer **252** is formed with a light visual angle pattern **250** when a transparent organic layer formed on the common electrode **220** is patterned. Also, the transparent spacer **252** has a thickness substantially equal to a height difference between the cell gap and color filter spacer **140**. Thus, the transparent spacer **252** may uniformly maintain the cell gap between the first and second substrates **100** and **200** with a color filter spacer **140**.

A light visual angle pattern **250** having a line shape is formed on the common electrode **220** corresponding to pixel areas **101**. The light visual angle pattern **250** is also formed with the transparent spacer **252** when the transparent organic layer is patterned. The light visual angle pattern **250** varies arrangement of liquid crystal **300** disposed between the first and second substrates **100** and **200** so as to widen a visual angle of an image. For widening the visual angle, the liquid crystal **300** has liquid crystal molecules vertically aligned.

In this exemplary embodiment, the transparent spacer **252** formed on the second substrate **200** connects between the color filter spacer **140** and common electrode **220** formed on the second substrate **210**. That is, the transparent spacer **252** has the thickness substantially equal to the height difference between the cell gap and color filter spacer **140**, thereby maintaining the cell gap between the first and second substrates **100** and **200**.

The light visual angle pattern **250** formed on the common electrode **220** increases brightness the light passing through the pixel areas **101**. Thus, an LCD apparatus **400** may widen

the visual angle of the image displayed thereon without decrease of brightness of the light passing through the pixel areas 101.

Embodiment 14

FIG. 17 is a cross-sectional view showing an LCD apparatus according to a fourteenth exemplary embodiment of the present invention. In FIG. 17, the same reference numerals denote the same elements in FIGS. 1 to 3, and thus the detailed descriptions of the same elements will be omitted.

Referring to FIG. 17, when a transparent organic layer formed on a second transparent substrate 210 of a second substrate 200 is patterned, a transparent spacer 250 and a transparent light visual angle pattern 252 are formed on the second transparent substrate 210. A common electrode 220 is formed over the second transparent substrate 210, and thus the transparent spacer 250 and transparent light visual angle pattern 252 are covered by means of the common electrode 200.

The common electrode 220 formed on the transparent spacer 250, transparent light visual angle pattern 252 and second transparent substrate 210 reinforces the transparent spacer 250, thereby preventing the transparent spacer 250 230 from being damaged due to an impact externally provided. Thus, a cell gap between the first and second substrates 100 and 200 may be uniformly maintained.

In this exemplary embodiment, in order to prevent the transparent spacer 250 from being damaged or deformed, the common electrode 220 is formed on the transparent spacer 250 and transparent light visual angle pattern 252. Thus, an LCD apparatus 400 may maintain the cell gap between the first and second substrates 100 and 200, thereby improving display quality thereof.

Embodiments of Manufacturing Method of a Surface Light Source Device

Embodiment 15

FIG. 18A is a cross-sectional view showing a first substrate having a driving voltage applying device according to a fifteenth exemplary embodiment of the present invention. FIG. 18B is a schematic circuit diagram showing a driving voltage applying device.

Referring to FIGS. 18A and 18B, a first transparent substrate 110 of a first substrate 100 includes a plurality of pixel areas 101 corresponding to a resolution of an LCD apparatus. For example, in case that the LCD apparatus performs a full color display and has a resolution of 1024×768, the first transparent substrate 110 includes the pixel areas of 1024×768×3 units.

Each of the pixel areas 101 includes a driving voltage applying device 120 having a TFT 120, a gate bus line 121 and data bus line 122.

In order to form the TFT 123, gate bus line 121 and data bus line 122, a gate metal thin-film layer is formed over the first transparent substrate 110. The gate metal thin-film layer is patterned through a photolithography process to form the gate bus line 121 and gate electrode portion G on the first transparent substrate 110.

The gate bus line 121 is formed on the first transparent substrate 110 and extended in a first direction D1. In case that the LCD apparatus has the resolution of 1024×768, the gate bus line 121 of 768 units are formed between the pixel areas 101. The gate electrode portion G is extended from a corresponding gate bus line to a corresponding pixel area. In this

exemplary embodiment, since the pixel areas 101 of 1024×3 units are formed in the first direction, the gate electrode portion G of 1024×3 units are formed against one gate bus line 121.

5 A gate insulating layer 121a is formed on the first transparent substrate 110 to cover the gate bus line 121 and gate electrode portion G.

An amorphous silicon layer, an n⁺ amorphous silicon layer and a source/drain metal layer are successively formed on the gate insulating layer 121a.

10 A photoresist pattern is formed on the source/drain layer by patterning a photoresist layer formed on the source/drain layer. When the amorphous silicon layer, n⁺ amorphous silicon layer and source/drain metal layer are successively etched using the photoresist pattern as a mask, the data bus line 122 extended in the second direction D2, a source electrode portion S and a drain electrode portion D are formed. Then, the photoresist pattern is removed through a photoresist strip process or an ashing process to form a channel layer C by the patterned n⁺ amorphous silicon layer.

FIG. 19 is a cross-sectional view showing a red color filter formed at pixel areas and a red color filter spacer formed between pixel areas shown in FIG. 18.

Referring to FIG. 19, a red color filter 132 is formed at every nth pixel area of the first transparent substrate 110, where n is a natural number. The red color filter 132 is formed by patterning a red color filter layer formed over the first transparent substrate 110 through a photolithography process. A contact hole 132a is formed with the red color filter 132 while the red color filter 132 is formed, through which the drain electrode D of the TFT 123 (refer to FIG. 18) covered by the red color filter 132 is partially exposed.

The red color filter spacer 132b is formed with the red color filter 132 while the red color filter 132 is formed, and disposed between the pixel areas 101. The red color filter spacer 132b performs a role as a color filter spacer (not shown) with green and blue color spacers described below for supporting a second substrate (not shown) combined with the first substrate 100.

FIG. 20 is a cross-sectional view showing a green color filter formed at pixel areas and a green color filter spacer formed between pixel areas shown in FIG. 18.

Referring to FIG. 20, a green color filter 134 is formed at every n+1st pixel area of the first transparent substrate 110, where n is a natural number. The green color filter 134 is formed by patterning a green color filter layer formed over the first transparent substrate 110 through a photolithography process. A contact hole 134a is formed with the green color filter 134 while the green color filter 134 is formed, through which the drain electrode D of the TFT 123 covered by the green color filter 134 is partially exposed.

The green color filter spacer 134b is formed with the green color filter 134 while the green color filter 134 is formed. The green color filter spacer 134b is disposed on the red color filter spacer 132b so as to perform the role as the color filter spacer (not shown) for supporting a second substrate (not shown) combined with the first substrate 100.

FIG. 21 is a cross-sectional view showing a blue color filter formed at pixel areas and a blue color filter spacer formed between pixel areas shown in FIG. 18.

Referring to FIG. 21, a blue color filter 136 is formed at every n+2nd pixel area of the first transparent substrate 110, where n is a natural number. The blue color filter 136 is formed by patterning a blue color filter layer formed over the first transparent substrate 110 through a photolithography process. A contact hole 136a is formed with the blue color filter 136 while the blue color filter 136 is formed, through

15

which the drain electrode D of the TFT **123** covered by the blue color filter **136** is partially exposed.

The blue color filter spacer **136b** is formed with the blue color filter **136** while the blue color filter **136** is formed. The blue color filter spacer **136b** is disposed on the green color filter spacer **134b** so as to perform the role as the color filter spacer (not shown) for supporting a second substrate (not shown) combined with the first substrate **100**.

FIG. **22** is a cross-sectional view showing a pixel electrode formed on the color filter shown in FIG. **21**.

Referring to FIG. **22**, a transparent and conductive layer comprising ITO or IZO is formed over the first substrate **100**. In this exemplary embodiment, the ITO layer is formed over the first transparent substrate **110** of the first substrate **100**.

The ITO layer is patterned to form the pixel electrode **150** on the red, green and blue color filters **132**, **134** and **136**. The pixel electrode **150** is electrically connected to the drain electrode D of the TFT **123** through the contact holes **132a**, **134a** and **136a** formed at the red, green and blue color filters **132**, **134** and **136**, respectively.

The first substrate **100** may further include an alignment layer (not shown) having an alignment groove formed thereon.

FIG. **23** is a cross-sectional view showing a second substrate of an LCD apparatus according to the fifteenth exemplary embodiment of the present invention.

Referring to FIG. **23**, a common electrode **220** is formed over a second transparent substrate **210** of a second substrate **200**. The common electrode **220** comprises the ITO layer or IZO layer.

FIG. **24** is a cross-sectional view showing a first substrate assembled with a second substrate of an LCD apparatus according to the fifteenth exemplary embodiment of the present invention.

Referring to FIG. **24**, the second substrate **200** on which the common electrode **220** is formed is assembled with the first substrate **100** on which the driving voltage applying device **120**, color filter **130** and pixel electrode **150** such that the common electrode **220** faces the pixel electrode **150**. The liquid crystal **300** is disposed between the first and second substrates **100** and **200**.

In this exemplary embodiment, the red, green and blue color filters **132**, **134** and **136** are formed at the n^{th} , $n+1^{\text{st}}$ and $n+2^{\text{nd}}$ pixel areas $n^{\text{th}}_{\text{PA}}$, $n+1^{\text{st}}_{\text{PA}}$ and $n+2^{\text{nd}}_{\text{PA}}$, respectively. The color filter spacer **140** having the red, green and blue color filter spacers **132b**, **134b** and **136b** sequentially stacked up each other is formed at a position between the n^{th} , $n+1^{\text{st}}$ and $n+2^{\text{nd}}$ pixel areas $n^{\text{th}}_{\text{PA}}$, $n+1^{\text{st}}_{\text{PA}}$ and $n+2^{\text{nd}}_{\text{PA}}$. The color filter spacer **140** may uniformly maintain the cell gap between the first and second substrates **100** and **200**. Thus, the LCD apparatus **400** does not need a separate spacer, thereby simplifying and reducing the processes, for example, such as forming a photoresist layer, patterning the photoresist layer and cleaning the patterned photoresist layer, for the LCD apparatus **400**.

Embodiment 16

FIGS. **25** and **26** are cross-sectional views showing a second substrate according to a sixteenth exemplary embodiment of the present invention. In FIGS. **25** and **26**, the same reference numerals denote the same elements in FIGS. **23** and **24**, and thus the detailed descriptions of the same elements will be omitted.

Referring to FIG. **25**, a light blocking layer **230b** that comprises an organic material having a light transmittance or

16

a light blocking rate substantially equal to that of a chromium Cr is formed over a second transparent substrate **210**.

Referring to FIG. **26**, the light blocking layer **230b** is patterned through a photolithography process to form a light blocking pattern **230** at a position between pixel areas PA. Thus, the light blocking pattern **230** transmits light incident through the pixel areas PA and blocks the light incident through between the pixel areas PA. The light blocking pattern **230** makes contact with an upper surface of the color filter spacer **140** formed on the first substrate **100** (refer to FIG. **24**).

A common electrode **220** comprising ITO or IZO is formed over the second transparent substrate **210** on which the light blocking pattern **230** is formed (refer to FIG. **7**).

In this exemplary embodiment, a color filter **130** is formed at the pixel areas PA of a first substrate **100** and a color filter spacer **140** is formed between the pixel areas PA. The color filter spacer **140** may uniformly maintain a cell gap between the first and second substrates **100** and **200**. Thus, an LCD apparatus **400** does not need a separate spacer, thereby simplifying and reducing the processes, for example, such as forming a photoresist layer, patterning the photoresist layer and cleaning the patterned photoresist layer, for the LCD apparatus **400**.

Embodiment 17

FIG. **27** is a cross-sectional view showing a second substrate according to a seventeenth exemplary embodiment of the present invention. In FIG. **27**, the same reference numerals denote the same elements in FIGS. **25** and **26**, and thus the detailed descriptions of the same elements will be omitted.

Referring to FIG. **27**, when a light blocking layer formed on the second transparent substrate **210** is patterned, a light visual angle pattern **232** is formed on the second transparent substrate **210** corresponding to pixel areas PA and a light blocking pattern **230** is formed between the pixel areas PA. The light visual angle pattern **232** and light blocking pattern **230** are substantially and simultaneously formed by patterning the light blocking layer. The light visual angle pattern **232** having a line shape widens a visual angle of an image and the light blocking pattern **230** blocks light incident through between the pixel areas PA, thereby improving display quality of the image. For improving the display quality, liquid crystal having liquid crystal molecules vertically aligned is disposed between the first and second substrates **100** and **200**.

In this exemplary embodiment, the light visual angle pattern **232** is formed on the second transparent substrate **210** corresponding to pixel areas PA and the light blocking pattern **230** is formed between the pixel areas PA. Thus, an LCD apparatus may improve the display quality of the image and be manufactured through simplified and reduced processes.

Embodiment 18

FIGS. **28** and **29** are cross-sectional views showing a second substrate according to an eighteenth exemplary embodiment of the present invention. In FIGS. **28** and **29**, the same reference numerals denote the same elements in FIGS. **25** and **26**, and thus the detailed descriptions of the same elements will be omitted.

Referring to FIGS. **28** and **29**, a light blocking pattern **230** is formed on a second transparent substrate **210** of a second substrate **200**. A common electrode **220** having ITO or IZO is formed over the second transparent substrate **210**, and then a transparent organic layer **238a** is formed over common electrode **220**.

The transparent organic layer **238a** is patterned through a photolithography process to form a transparent spacer **238** on the common electrode **220** corresponding to the light blocking pattern **230**. The transparent spacer **238** faces an upper surface of a color filter spacer **140** formed on a first substrate **100** (refer to FIG. **14**). When the first and second substrates **100** and **200** are assembled with each other, the transparent spacer **238** makes contact with the upper surface of the color filter spacer **140** to uniformly maintain a cell gap between the first and second substrates **100** and **200**.

In this exemplary embodiment, the cell gap between the first and second substrates **100** and **200** may be uniformly maintained by means of the color filter spacer **140** formed on the first substrate **100**, light blocking pattern **230** formed on the second substrate **200** corresponding to the color filter spacer **140** and transparent spacer **238**.

Thus, an LCD apparatus does not need a separate spacer, thereby simplifying and reducing the processes, for example, such as forming a photoresist layer, patterning the photoresist layer and cleaning the patterned photoresist layer, for the LCD apparatus. Also, the LCD apparatus may provide an improved display quality because of the light blocking pattern **230** formed at a position between the pixel areas PA.

Embodiment 19

FIG. **30** is a cross-sectional view showing a second substrate according to a nineteenth exemplary embodiment of the present invention. In FIG. **30**, the same reference numerals denote the same elements in FIGS. **28** and **29**, and thus the detailed descriptions of the same elements will be omitted.

Referring to FIG. **30**, a light blocking pattern **230** is formed on a second transparent substrate **210** of a second substrate **200**. A common electrode **220** having ITO or IZO is formed over the second transparent substrate **210**, and then a transparent organic layer is formed over common electrode **220**. The transparent organic layer is patterned through a photolithography process to form a transparent spacer **238** on the common electrode **220** corresponding to the light blocking pattern **230**.

The transparent spacer **238** is disposed at a position facing an upper surface of a color filter spacer **140** formed on a first substrate **100** (refer to FIG. **14**). When the first and second substrates **100** and **200** are assembled with each other, the transparent spacer **238** makes contact with the upper surface of the color filter spacer **140** to uniformly maintain a cell gap between the first and second substrates **100** and **200**. A light visual angle pattern **236** is formed on the common electrode **220** corresponding to the pixel areas PA while the transparent spacer **238** is formed. The light visual angle pattern **236** widens a visual angle of an image. In this exemplary embodiment, in order to widen the visual angle of the image without decrease of brightness, liquid crystal having liquid crystal molecules vertically aligned is disposed between the first and second substrates **100** and **200**.

In this exemplary embodiment, the cell gap between the first and second substrates **100** and **200** may be uniformly maintained by means of the color filter spacer **140** formed on the first substrate **100**, light blocking pattern **230** formed on the second substrate **200** corresponding to the color filter spacer **140** and transparent spacer **238**.

Thus, an LCD apparatus does not need a separate spacer, thereby simplifying and reducing the processes, for example, such as forming a photoresist layer, patterning the photoresist layer and cleaning the patterned photoresist layer, for the LCD apparatus. Also, the LCD apparatus may provide an

improved display quality because of the light blocking pattern **230** formed at a position between the pixel areas PA.

Embodiment 20

FIGS. **31** to **33** are cross-sectional views showing a second substrate according to a twentieth exemplary embodiment of the present invention. In FIGS. **31** to **33**, the same reference numerals denote the same elements in FIGS. **18A** to **24**, and thus the detailed descriptions of the same elements will be omitted.

Referring to FIG. **31**, a light blocking layer **230a** comprising chromium Cr or a double-layer light blocking layer comprising chromium Cr and chromium oxide CrO₂ is formed over a second transparent substrate **210** of a second substrate **200**. In this exemplary embodiment, the light blocking layer **230a** comprises the chromium Cr.

A photosensitive layer comprising a photosensitive material is formed over the light blocking layer **230a**.

Referring to FIG. **32**, the photosensitive layer **240a** is patterned to form a photosensitive pattern **240** on the light blocking layer **230a**. The photosensitive pattern **240** has a lattice-shape and is formed at a position between the pixel areas PA.

Referring to FIG. **33**, the light blocking layer **230a** is patterned using the photosensitive pattern **240** as a mask. Thus, a light blocking pattern **230** is formed at a position on the second transparent substrate **210** corresponding to the photosensitive pattern **240**. A common electrode **220** comprising ITO or IZO on the light blocking pattern **230** (refer to FIG. **11**).

In this exemplary embodiment, the photosensitive pattern **240** is formed on the light blocking pattern **230** formed on the second transparent substrate **210**. The photosensitive pattern **240** makes contact with the color filter spacer **140** formed on the first substrate **100**, thereby uniformly maintaining the cell gap between the first and second substrates **100** and **200**.

Embodiment 21

FIGS. **34** and **35** are cross-sectional views showing a second substrate according to a twenty-first exemplary embodiment of the present invention. In FIGS. **34** and **35**, the same reference numerals denote the same elements in FIGS. **31** to **33**, and thus the detailed descriptions of the same elements will be omitted.

Referring to FIG. **34**, a light blocking layer **230a** comprising chromium Cr or a double-layer light blocking layer comprising chromium Cr and chromium oxide CrO₂ is formed over a second transparent substrate **210** of a second substrate **200**. In this exemplary embodiment, the light blocking layer **230a** comprises the chromium Cr.

A photosensitive layer comprising a photosensitive material is formed over the light blocking layer **230a**. The photosensitive layer is patterned to form a photosensitive pattern **240** and a first light visual angle pattern **242** on the light blocking layer **230a**.

The photosensitive pattern **240** having a lattice-shape is formed at a position between the pixel areas PA. The first light visual angle pattern **242** having a line shape is formed at a position corresponding to the pixel areas PA.

Referring to FIG. **35**, the light blocking layer **230a** is patterned using the photosensitive pattern **240** and first light visual angle pattern **242** as a mask. Thus, a light blocking pattern **230** is formed at a position on the second transparent substrate **210** corresponding to the photosensitive pattern **240**. Also, a second light visual angle pattern **234** is formed at position on the second transparent substrate **210** correspond-

ing to the first light visual angle pattern **242**. A common electrode **220** comprising ITO or IZO on the photosensitive pattern **240**, first light visual angle pattern **242** and second transparent substrate **210** (refer to FIG. **12**).

In this exemplary embodiment, the photosensitive pattern **240** is formed on the light blocking pattern **230** formed on the second transparent substrate **210**. The photosensitive pattern **240** makes contact with the color filter spacer **140** formed on the first substrate **100**, thereby uniformly maintaining the cell gap between the first and second substrates **100** and **200**. Also, since the first and second light visual angle pattern **242** and **234** are formed with the photosensitive pattern **240** and light blocking pattern **230**, respectively, an LCD apparatus may be manufactured through simplified and reduced processes.

Embodiment 22

FIGS. **36** and **37** are cross-sectional views showing a second substrate according to a twenty-second exemplary embodiment of the present invention. In FIGS. **36** and **37**, the same reference numerals denote the same elements in FIGS. **25** and **26**, and thus the detailed descriptions of the same elements will be omitted.

Referring to FIG. **36**, a common electrode **220** comprising ITO or IZO is formed over a second transparent substrate **210**. A light blocking layer **230b** that comprises an organic material having a light transmittance or a light blocking rate substantially equal to that of a chromium Cr is formed over the common electrode **220**.

Referring to FIG. **37**, the light blocking layer **230b** is patterned through a photolithography process to form a light blocking pattern **230** at a position between pixel areas PA. The light blocking pattern **230** transmits light incident through the pixel areas PA, and blocks the light incident through between the pixel areas PA. The light blocking pattern **230** makes contact with an upper surface of the color filter spacer **140** formed on a first substrate **100** (refer to FIG. **24**).

In this exemplary embodiment, the light blocking pattern **230** disposed at a position between the pixel areas PA is formed on the common electrode **220**. The light blocking pattern **230** makes contact with the upper surface of the color filter spacer **140**, thereby uniformly maintaining a cell gap between the first and second substrates **100** and **200**. Thus, an LCD apparatus may be manufactured through simplified and reduced processes because the LCD apparatus does not need a separate spacer for maintaining the cell gap.

Embodiment 23

FIG. **38** is a cross-sectional view showing a second substrate according to a twenty-third exemplary embodiment of the present invention. In FIG. **38**, the same reference numerals denote the same elements in FIGS. **36** and **37**, and thus the detailed descriptions of the same elements will be omitted.

Referring to FIG. **38**, a common electrode **220** comprising ITO or IZO is formed over a second transparent substrate **210**. A light blocking layer **230b** that comprises an organic material having a light transmittance or a light blocking rate substantially equal to that of a chromium Cr is formed over the common electrode **220**. The light blocking layer **230b** is patterned through a photolithography process to form a light blocking pattern **230** at a position between pixel areas PA and to form a light visual angle pattern **232** at a position corresponding to the pixel areas PA. The light blocking pattern **230** blocks the light incident through between the pixel areas PA

and the light visual angle pattern **232** improves a visual angle of light incident into the pixel areas PA to widen the visual angle of an image.

When the first and second transparent substrates **110** and **210** are assembled with each other, the light blocking pattern **230** makes contact with an upper surface of the color filter spacer **140** formed on a first substrate **100** (refer to FIG. **5**).

In this exemplary embodiment, the light blocking pattern **230** is formed on the common electrode **220**, and disposed at a position between the pixel areas PA. The light visual angle pattern **232** is formed on the common electrode **220**, and disposed at a position corresponding to the pixel areas PA. The light blocking pattern **230** makes contact with the upper surface of the color filter spacer **140**, thereby uniformly maintaining a cell gap between the first and second substrates **100** and **200**. Thus, an LCD apparatus may block the light incident through between the pixel areas PA. Also, the LCD apparatus may be manufactured through simplified and reduced processes because the LCD apparatus does not need a separate spacer for maintaining the cell gap. Moreover, since the light visual pattern **232** widens the visual angle of the light incident into the pixel areas PA, the LCD apparatus may improve display quality of the image.

Embodiment 24

FIGS. **39** and **40** are cross-sectional views showing a second substrate according to a twenty-fourth exemplary embodiment of the present invention. In FIGS. **39** and **40**, the same reference numerals denote the same elements in FIGS. **28** and **29**, and thus the detailed descriptions of the same elements will be omitted.

Referring to FIG. **39**, a common electrode **220** having ITO or IZO is formed over the second transparent substrate **210** of a second substrate **200**. A light blocking layer is formed over common electrode **220**, and then the light blocking layer is patterned to form a light blocking pattern **230** on the common electrode **220** that is formed on the second transparent substrate **210**.

A transparent organic layer **238a** is formed over common electrode **220** on which the light blocking pattern **230** is formed.

Referring to FIG. **40**, the transparent organic layer **238a** is patterned through a photolithography process to form a transparent spacer **238** on the light blocking pattern **230**. The transparent spacer **238** is formed at position facing an upper surface of a color filter spacer **140** formed on a first substrate **100**. When the first and second substrates **100** and **200** are assembled with each other, the transparent spacer **238** makes contact with the upper surface of the color filter spacer **140** to uniformly maintain a cell gap between the first and second substrates **100** and **200**.

In this exemplary embodiment, the cell gap between the first and second substrates **100** and **200** may be uniformly maintained by means of the common electrode **220**, light blocking pattern **230** and transparent spacer **238** sequentially formed on the second transparent substrate **210** with the color filter spacer **140** that is formed on the first transparent substrate **110**. Thus, an LCD apparatus does not need a separate spacer, thereby simplifying and reducing the processes, for example, such as forming a photoresist layer, patterning the photoresist layer and cleaning the patterned photoresist layer, for the LCD apparatus. Also, the LCD apparatus may provide an improved display quality because the light blocking pattern **230** may block the light incident through between the pixel areas PA.

Embodiment 25

FIG. 41 is cross-sectional view showing a second substrate according to a twenty-fifth exemplary embodiment of the present invention. In FIG. 41, the same reference numerals denote the same elements in FIGS. 39 and 40, and thus the detailed descriptions of the same elements will be omitted.

Referring to FIG. 41, when a transparent organic layer formed on a second transparent substrate 210 on which a common electrode 220 and a light blocking pattern 230 are formed, a transparent spacer 238 is formed on the light blocking pattern 230 formed at position between pixel areas PA, and a light visual angle pattern 236 is formed at a position corresponding to the pixel areas PA. The light visual angle pattern 236 improves properties of light incident into the pixel areas PA to widen a visual angle of an image. In this exemplary embodiment, in order to widen the visual angle of the image without decrease of brightness, liquid crystal having liquid crystal molecules vertically aligned is disposed between the first and second substrates 100 and 200.

In this exemplary embodiment, a common electrode 220 is formed on the second transparent substrate 210. The light blocking pattern 230 and transparent spacer 238 are formed at the position between the pixel areas PA, and the light visual angle pattern 236 is formed at the position corresponding to the pixel areas PA.

The transparent spacer 238 may uniformly maintain a cell gap between the first and second transparent substrates 110 and 210 with a color filter spacer 140 formed on the first transparent substrate 110. Thus, an LCD apparatus does not need a separate spacer, thereby simplifying and reducing the processes, for example, such as forming a photoresist layer, patterning the photoresist layer and cleaning the patterned photoresist layer, for the LCD apparatus. Also, the LCD apparatus may provide an improved display quality because the light blocking pattern 230 may block the light incident through between the pixel areas PA.

Embodiment 26

FIGS. 42 to 44 are cross-sectional views showing a second substrate according to a twenty-sixth exemplary embodiment of the present invention. In FIGS. 42 to 44, the same reference numerals denote the same elements in FIG. 11, and thus the detailed descriptions of the same elements will be omitted.

Referring to FIG. 42, a common electrode 220 comprising ITO or IZO is formed over a second transparent substrate 210 of a second substrate 200. A light blocking layer 230a comprising chromium Cr or a double-layer light blocking layer comprising chromium Cr and chromium oxide CrO₂ is formed on the common electrode 220. In this exemplary embodiment, the light blocking layer 230a comprises the chromium Cr.

A photosensitive layer 240a comprising a photosensitive material is formed over the light blocking layer 230a. The photosensitive layer 240a is patterned to form a photosensitive pattern 240 at a position between pixel areas PA.

When the light blocking layer 230a is patterned using the photosensitive pattern 240 as a mask, a light blocking pattern 230 is formed under the photosensitive pattern 240.

In this exemplary embodiment, the light blocking pattern 230 and photosensitive pattern 240 are successively formed on the common electrode 220 and disposed between the pixel areas PA. When a first transparent substrate 110 is combined with the second transparent substrate 210, the photosensitive pattern 240 makes contact with a color filter spacer 140

formed on the first transparent substrate 110, thereby uniformly maintaining a cell gap between the first and second substrates 100 and 200.

Embodiment 27

FIGS. 45 and 46 are cross-sectional views showing a second substrate according to a twenty-seventh exemplary embodiment of the present invention. In FIGS. 45 and 46, the same reference numerals denote the same elements in FIGS. 42 to 44, and thus the detailed descriptions of the same elements will be omitted.

Referring to FIG. 45, a common electrode 220 comprising ITO or IZO is formed over a second transparent substrate 210 of a second substrate 200. A light blocking layer 230a comprising chromium Cr or a double-layer light blocking layer comprising chromium Cr and chromium oxide CrO₂ is formed on the common electrode 220. In this exemplary embodiment, the light blocking layer 230a comprises the chromium Cr.

A photosensitive layer 240a comprising a photosensitive material is formed over the light blocking layer 230a. The photosensitive layer 240a is patterned to form a first light visual angle pattern 242 having a line shape at a position corresponding to pixel areas PA and to form a photosensitive pattern 240 at a position between the pixel areas PA.

When the light blocking layer 230a is patterned using the photosensitive pattern 240 and first light visual angle pattern 242 as a mask, a second light visual angle pattern 234 and a light blocking pattern 230 are formed under the first light visual angle pattern 242 and photosensitive pattern 240, respectively.

In this exemplary embodiment, the light blocking pattern 230 and photosensitive pattern 240 are successively formed on the position between the pixel areas PA. When a first transparent substrate 110 is combined with the second transparent substrate 210, the photosensitive pattern 240 makes contact with a color filter spacer 140 formed on the first transparent substrate 110, thereby uniformly maintaining a cell gap between the first and second substrates 100 and 200. Also, the second and first light visual angle patterns 234 and 242 are successively formed on the position corresponding to the pixel areas PA. The first and second light visual angle patterns 242 and 234 improve properties of light incident into the pixel areas PA to widen a visual angle of an image.

In those exemplary embodiments aforementioned above, the color filter and color filter spacer formed on the first substrate on which the pixel electrode is formed has been described. However, the color filter and color filter spacer may be formed on the second substrate facing the first substrate on which the pixel electrode is formed. Also, the TFT manufactured using 4 masks has been described, but the TFT may be manufactured using 5 masks.

According to the LCD apparatus and method of manufacturing the same, a spacer for maintaining a cell gap between first and second substrates may be substantially and simultaneously formed with a color filter that is formed on a first substrate on which a pixel electrode is formed. Thus, the LCD apparatus may be manufactured through simplified and reduced processes.

Also, the second substrate includes a light visual angle pattern substantially and simultaneously formed with a light blocking pattern formed thereon, thereby improving display quality of an image.

Although the exemplary embodiments of the present invention have been described, it is understood that the present invention should not be limited to these exemplary

embodiments but various changes and modifications can be made by one ordinary skilled in the art within the spirit and scope of the present invention as hereinafter claimed.

What is claimed is:

1. A liquid crystal display apparatus, comprising:
a first panel including:
a first transparent substrate having a pixel area;
a thin film transistor disposed at the pixel area so as to output a pixel voltage;
a first color filter disposed at the pixel area, the first color filter having a first edge;
a second color filter disposed adjacent to the first color filter and having a second edge, the first edge and the second edge being overlapped to provide an overlapped area between the first color filter and the second color filter;
a spacer disposed on the overlapped area between the first color filter and the adjacent second color filter, the spacer having a same material as one of the first color filter and the second color filter; and
a pixel electrode disposed on the first color filter so as to receive the pixel voltage;
a second panel including:
a second transparent substrate;
a light blocking pattern formed on the second transparent substrate;
a common electrode disposed on the second transparent substrate having the light blocking pattern formed thereon, a protruding portion of the common electrode protruded by the light blocking pattern making contact with an end portion of the spacer;
a light visual angle pattern disposed on the common electrode and formed at a position corresponding to the pixel area so as to widen a visual angle of an image displayed by the liquid crystal display apparatus, the light visual angle pattern including a same material as the light blocking pattern; and
a liquid crystal layer disposed between the first and second panels, wherein an opening is formed through each of the first color filter and the second color filter to partially expose the thin film transistor, and the pixel electrode is electrically connected to the thin film transistor through the opening,
wherein the light visual angle pattern is disposed between the common electrode and the liquid crystal layer.
2. The liquid crystal display apparatus of claim 1, wherein a first color filter comprises a red color filter, a green color filter and a blue color filter, and the spacer comprises at least one of a red color filter, a green color filter and a blue color filter.
3. The liquid crystal display apparatus of claim 1, wherein the light blocking pattern has a lattice-shape that transmits light incident into the pixel area and blocks light incident into between the pixel area and an adjacent pixel area.
4. The liquid crystal display apparatus of claim 3, wherein the liquid crystal layer comprises liquid crystal molecules vertically aligned.
5. The liquid crystal display apparatus of claim 1, wherein the light blocking pattern has a lattice-shape, which is disposed between the second transparent substrate and common

electrode and formed at a position corresponding to a space between the pixel area and adjacent pixel area, so as to block light incident into between the pixel area and an adjacent pixel area.

6. The liquid crystal display apparatus of claim 5, wherein the liquid crystal layer comprises liquid crystal molecules vertically aligned.
7. The liquid crystal display apparatus of claim 1, wherein the second panel further comprises:
the light blocking pattern having a lattice-shape, which is formed at a position corresponding to a space between the pixel area and adjacent pixel area, so as to block light incident into between the pixel area and an adjacent pixel area; and
a photosensitive pattern disposed on the light blocking pattern.
8. The liquid crystal display apparatus of claim 7, wherein the liquid crystal layer comprises liquid crystal molecules vertically aligned, and the second panel further comprises a first light visual angle pattern disposed on the common electrode and formed at a position corresponding to the pixel area so as to widen a visual angle of an image; and
a second light visual angle pattern disposed on the first light visual angle pattern.
9. The liquid crystal display apparatus of claim 1, wherein the second panel further comprises:
the light blocking pattern having a lattice-shape, which is disposed between the second transparent substrate and common electrode and formed at a position corresponding to a space between the pixel area and an adjacent pixel area, the light blocking pattern that transmits light incident into the pixel area and blocks light incident into between the pixel area and the adjacent pixel area; and
a photosensitive pattern disposed on the light blocking pattern.
10. The liquid crystal display apparatus of claim 9, wherein the liquid crystal layer comprises liquid crystal molecules vertically aligned, and the second panel further comprises a first light visual angle pattern disposed between the first transparent substrate and common electrode and formed at a position corresponding to the pixel area so as to widen a visual angle of an image and a second light visual angle pattern disposed on the first light visual angle pattern.
11. The liquid crystal display apparatus of claim 1, wherein the second panel further comprises a transparent spacer disposed on the common electrode corresponding to the light blocking pattern.
12. The liquid crystal display apparatus of claim 1, wherein the liquid crystal layer comprises liquid crystal molecules vertically aligned, and the second panel further comprises a light visual angle pattern disposed between the common electrode and second transparent substrate and formed at a position corresponding to the pixel area so as to widen a visual angle of an image.
13. The liquid crystal display apparatus of claim 1, wherein the spacer has a column shape, the spacer being configured to maintain a cell gap between the first substrate and the second substrate.
14. The liquid crystal display apparatus of claim 1, wherein the common electrode makes direct contact with the spacer.

专利名称(译)	液晶显示装置		
公开(公告)号	US8107047	公开(公告)日	2012-01-31
申请号	US10/719103	申请日	2003-11-21
[标]申请(专利权)人(译)	三星电子株式会社		
申请(专利权)人(译)	SAMSUNG ELECTRONICS CO., LTD.		
当前申请(专利权)人(译)	三星DISPLAY CO., LTD.		
[标]发明人	SONG JANG KUN		
发明人	SONG, JANG-KUN		
IPC分类号	G02F1/1339 G02F1/1335 G02F1/1333 G02F1/1337		
CPC分类号	G02F1/13394 G02F1/133514		
优先权	1020030037835 2003-06-12 KR		
其他公开文献	US20040252271A1		
外部链接	Espacenet	USPTO	

摘要(译)

液晶显示 (LCD) 设备包括第一面板，第二面板和设置在第一和第二面板之间的液晶层。第一面板包括具有像素区域的第一透明基板，设置在像素区域以输出像素电压的薄膜晶体管，设置在像素区域的第一滤色器，具有第一边缘的第一滤色器，第二滤色器，设置在第一滤色器附近并具有第二边缘，第一边缘和第二边缘重叠，以提供第一滤色器和第二滤色器之间的重叠区域，间隔物设置在第一滤色器和第二滤色器之间的重叠区域上第一滤色器和相邻的第二滤色器，以及设置在第一滤色器上的像素电极，以接收像素电压。间隔物具有与第一滤色器和第二滤色器中的一个相同的材料。第二面板包括第二透明基板和设置在第二透明基板上的公共电极。

