



US007567228B1

(12) **United States Patent**
Wen et al.

(10) **Patent No.:** **US 7,567,228 B1**
(45) **Date of Patent:** **Jul. 28, 2009**

(54) **MULTI SWITCH PIXEL DESIGN USING COLUMN INVERSION DATA DRIVING**

Primary Examiner—Vijay Shankar
(74) *Attorney, Agent, or Firm*—Morris Manning Martin LLP; Tim Tingkang Xia, Esq.

(75) Inventors: **Yi-Chien Wen**, Hsinchu (TW);
Chao-Liang Lu, Hsinchu (TW);
Ken-Ming Chen, Hsinchu (TW);
Chi-Mao Hung, Hsinchu (TW);
Chun-Huai Li, Hsinchu (TW); **Jing-Tin Kuo**, Hsinchu (TW); **Chang-Wei Su**, Hsinchu (TW); **Yao-Jen Hsieh**, Hsinchu (TW)

(57) **ABSTRACT**

A liquid crystal display (LCD) panel with power consumption reduction and methods of driving same. In one embodiment, the LCD panel includes a pixel matrix, a plurality of scanning lines and a plurality of data lines. Each pair of two neighboring scanning lines defines a pixel row therebetween, and each pair of two neighboring data lines defines a pixel column therebetween. Each pixel has at least a first sub-pixel and a second sub-pixel. Each sub-pixel has a sub-pixel electrode and a switching element electrically coupled to the sub-pixel electrode. Each pair of two neighboring scanning lines is electrically coupled to the switching elements of the first sub-pixel and the second sub-pixel of each pixel in the pixel row, respectively. Each data line is electrically coupled to the switching element of the first sub-pixel or the second sub-pixel of each odd pixel of one of two neighboring pixel columns associated with the data line and to the switching element of the second sub-pixel or the first sub-pixel of each even pixel of the other of the two neighboring pixel columns. The LCD panel further includes a gate driver and a data driver for generating scanning signals and data signals applied to the plurality of scanning lines and the plurality of data lines, respectively. The scanning signals are configured to turn on the switching elements connected to the plurality of scanning lines in a predefined sequence, and the data signals are configured such that any two neighboring data signals have inverted polarities.

(73) Assignee: **AU Optonics Corporation**, Hsinchu (TW)

(*) Notice: Subject to any disclaimer, the term of this patent is extended or adjusted under 35 U.S.C. 154(b) by 0 days.

(21) Appl. No.: **12/204,443**

(22) Filed: **Sep. 4, 2008**

(51) **Int. Cl.**
G09G 3/36 (2006.01)

(52) **U.S. Cl.** **345/87**; 345/89; 345/96;
345/204; 345/209; 345/211

(58) **Field of Classification Search** 345/87–104,
345/204–215, 690–699
See application file for complete search history.

(56) **References Cited**

U.S. PATENT DOCUMENTS

7,061,478 B1 *	6/2006	Moyer	345/204
7,260,494 B2 *	8/2007	Weiss	702/120
7,289,095 B2 *	10/2007	Park et al.	345/98

* cited by examiner

41 Claims, 16 Drawing Sheets

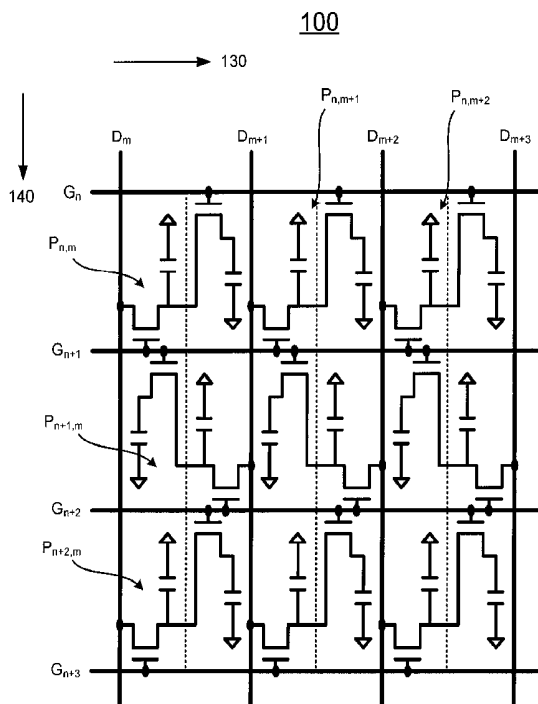

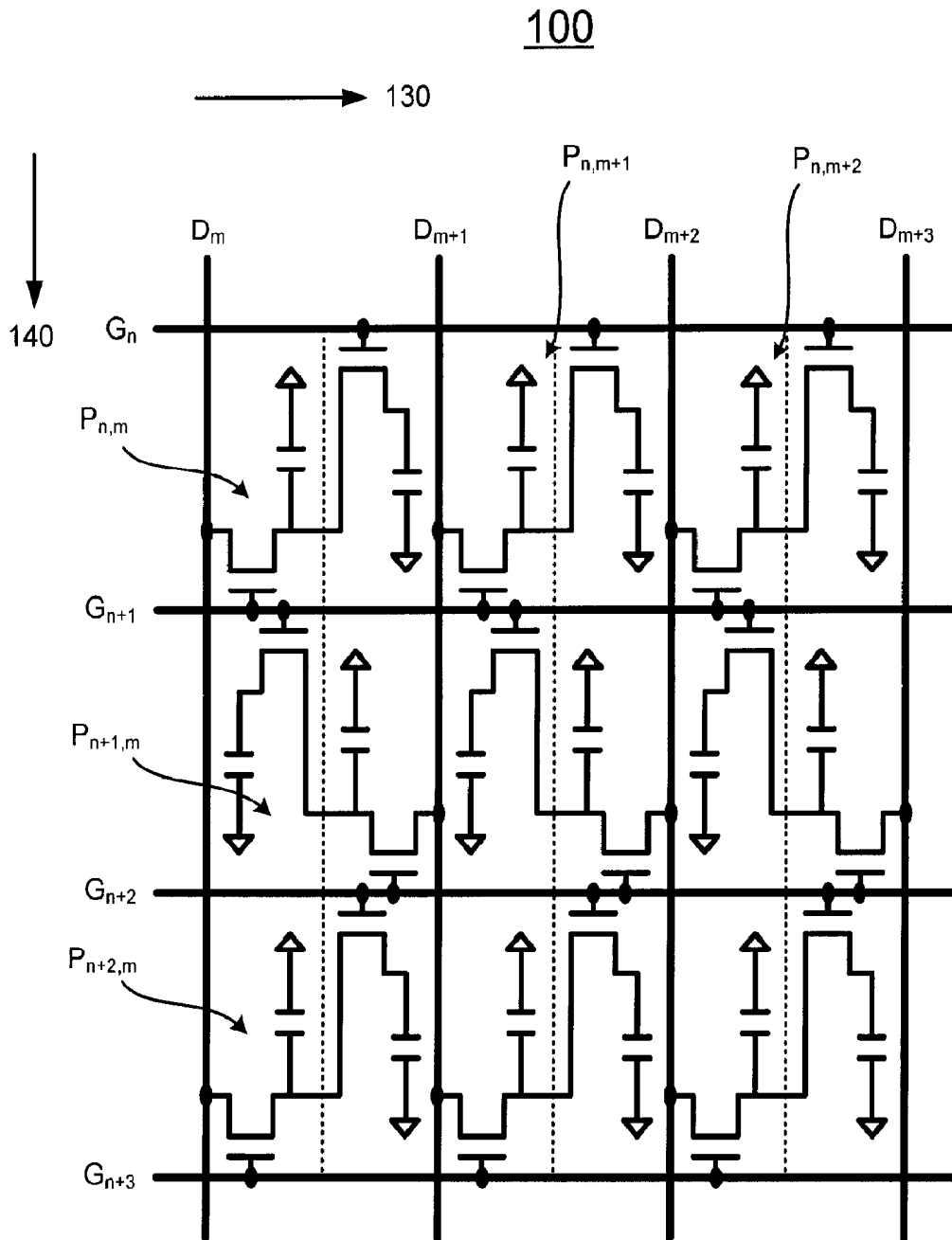

Fig. 1

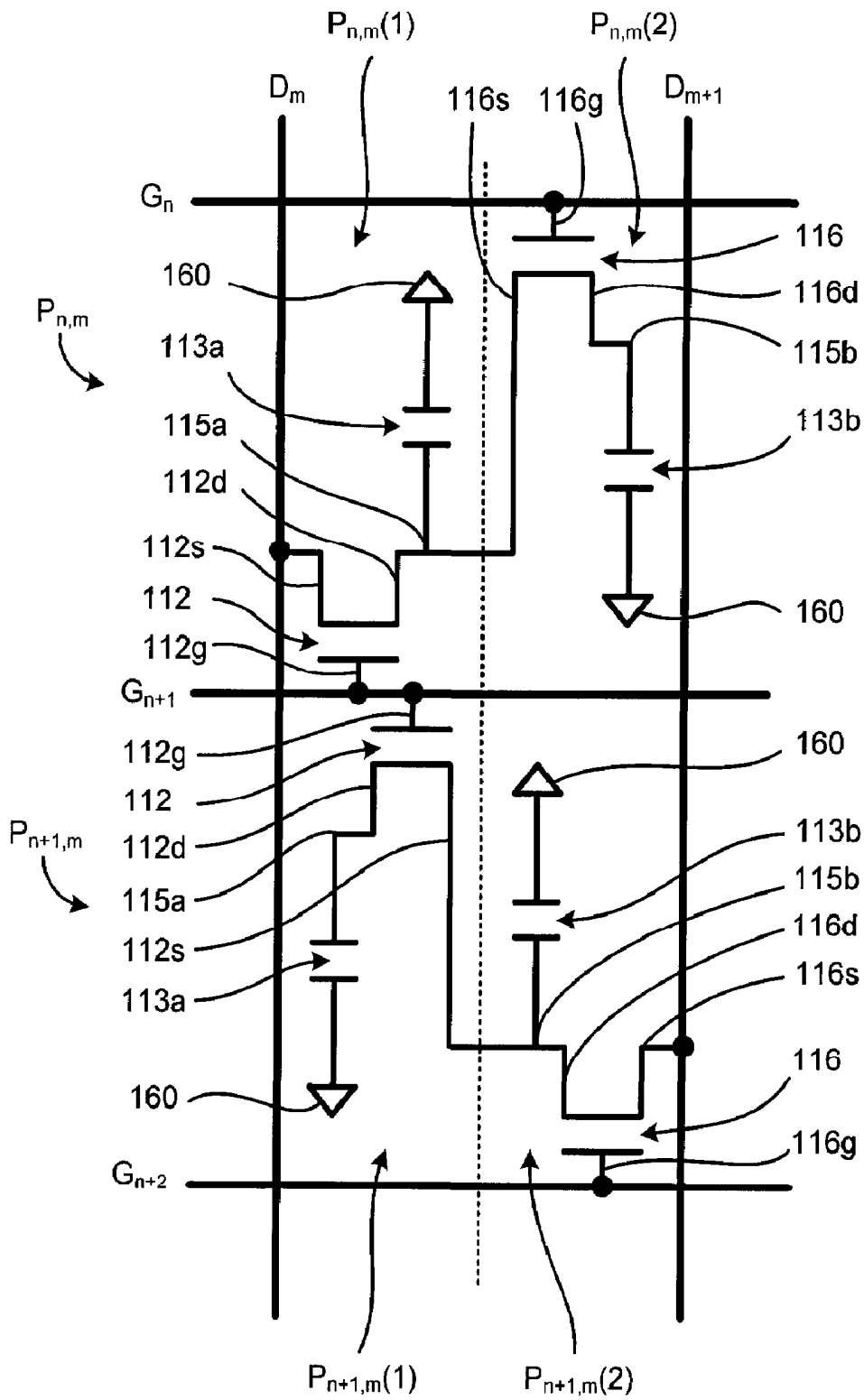

Fig. 2

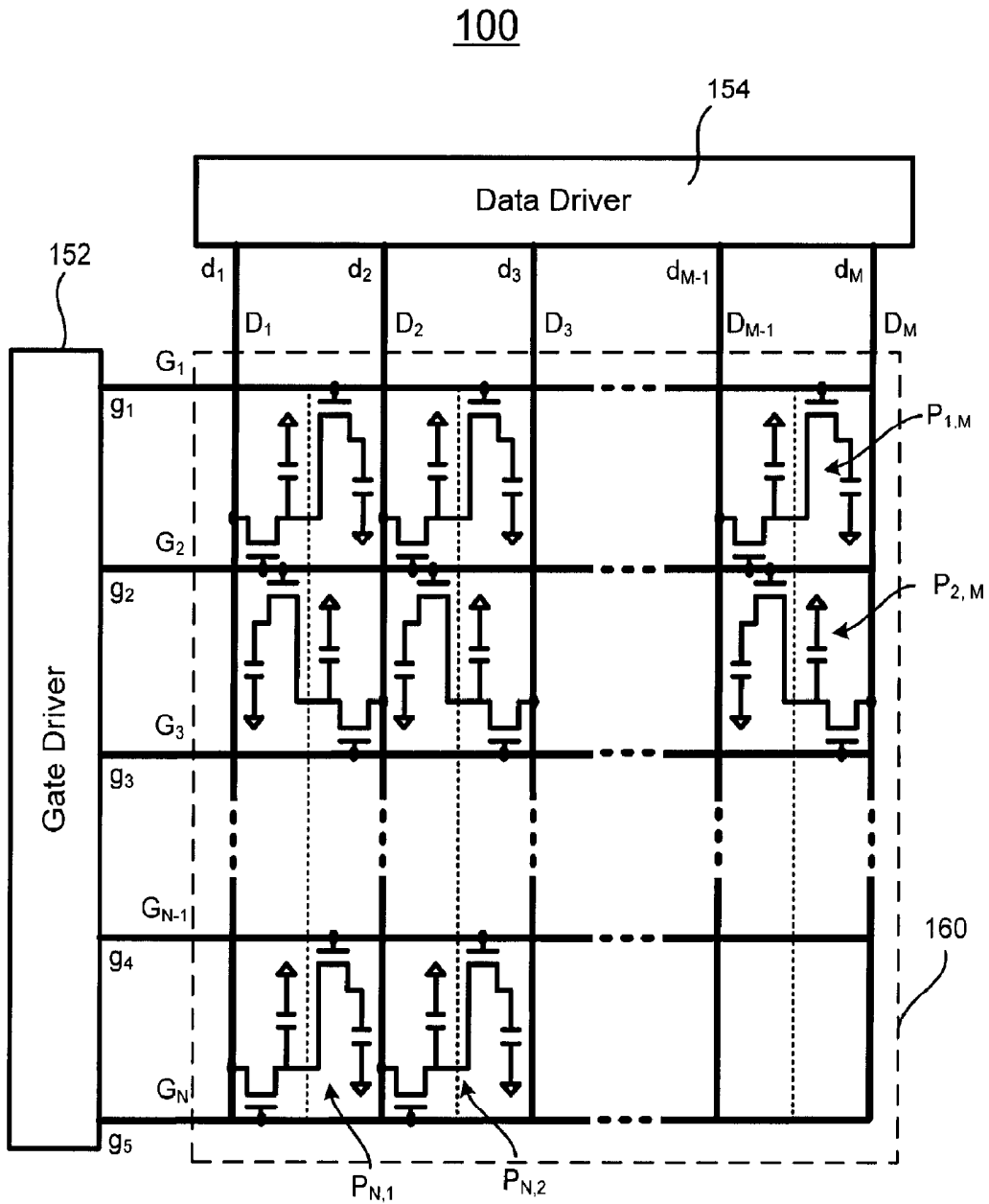

Fig. 3

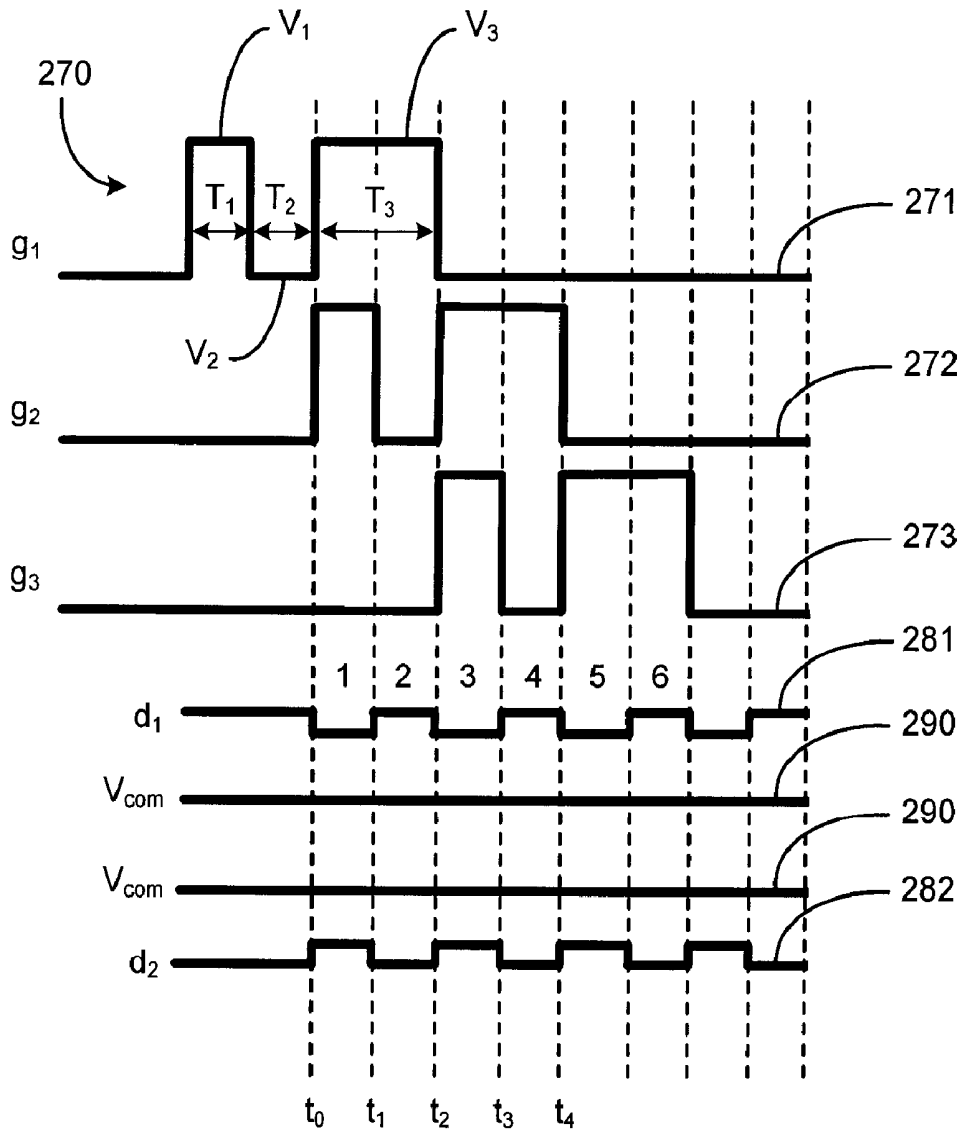

Fig. 4

200

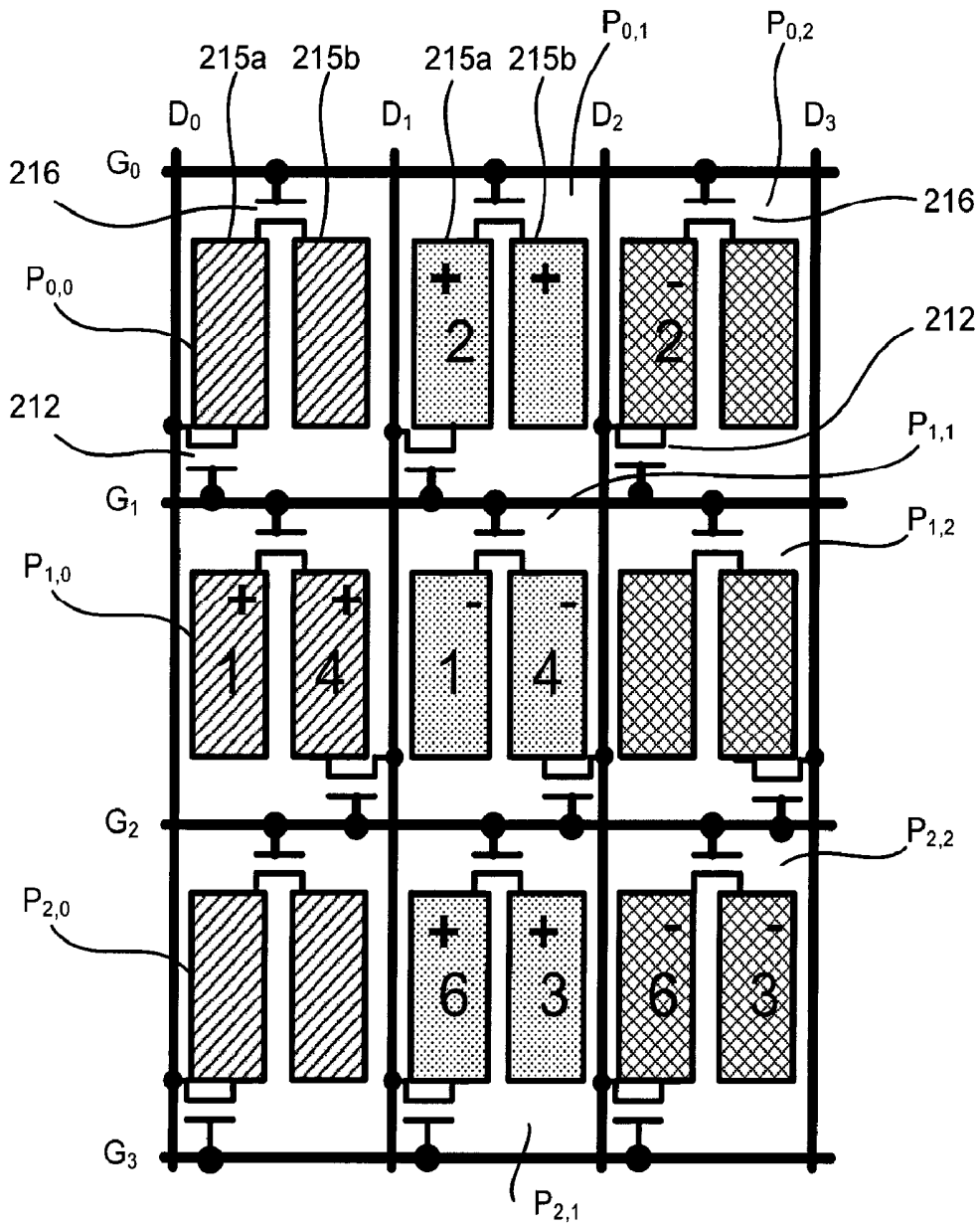

Fig. 5

300

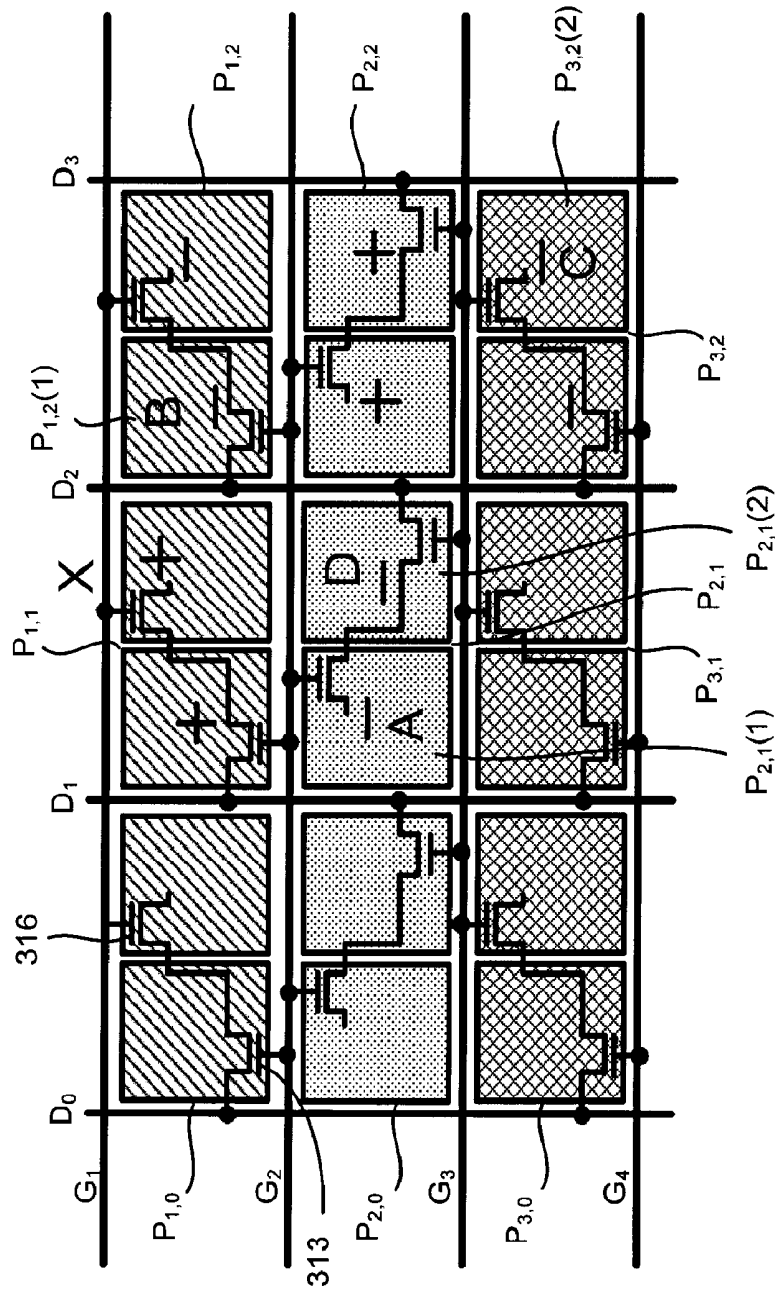

Fig. 6

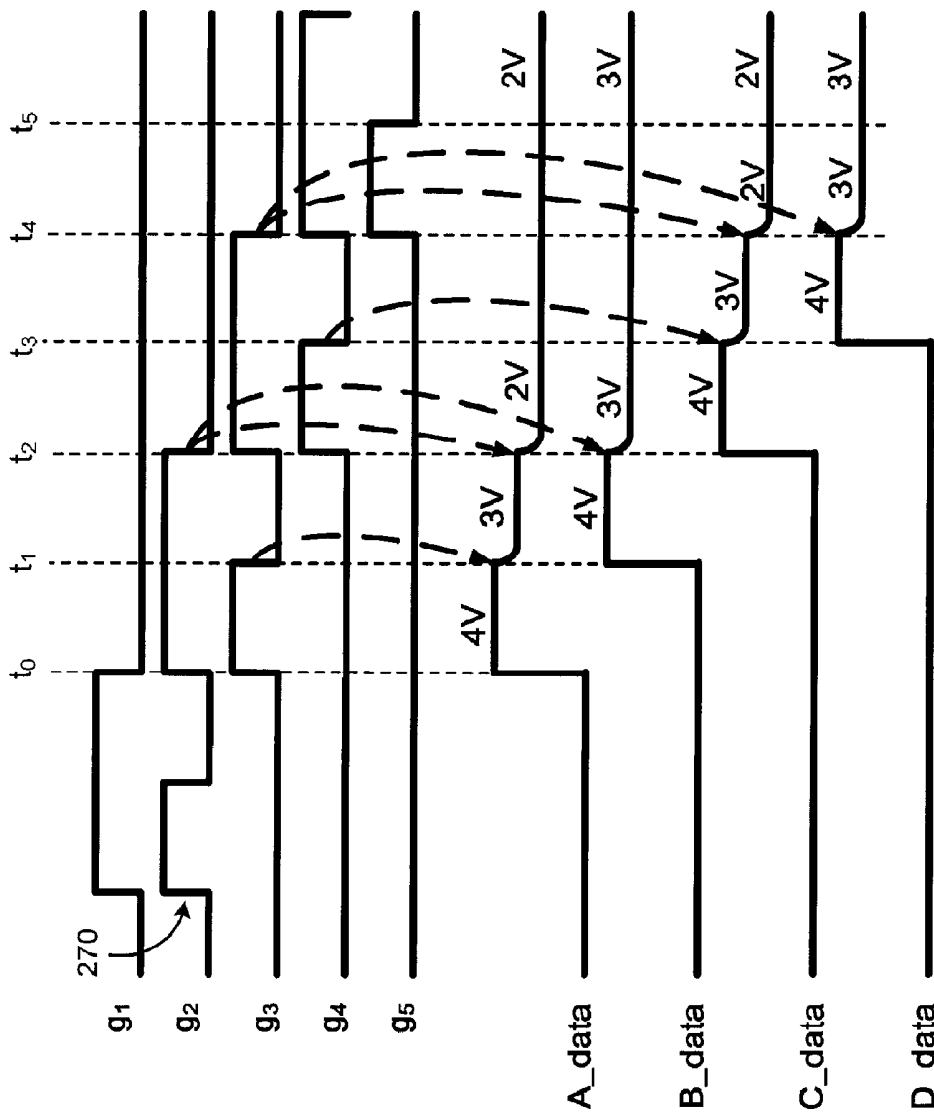

Fig. 7

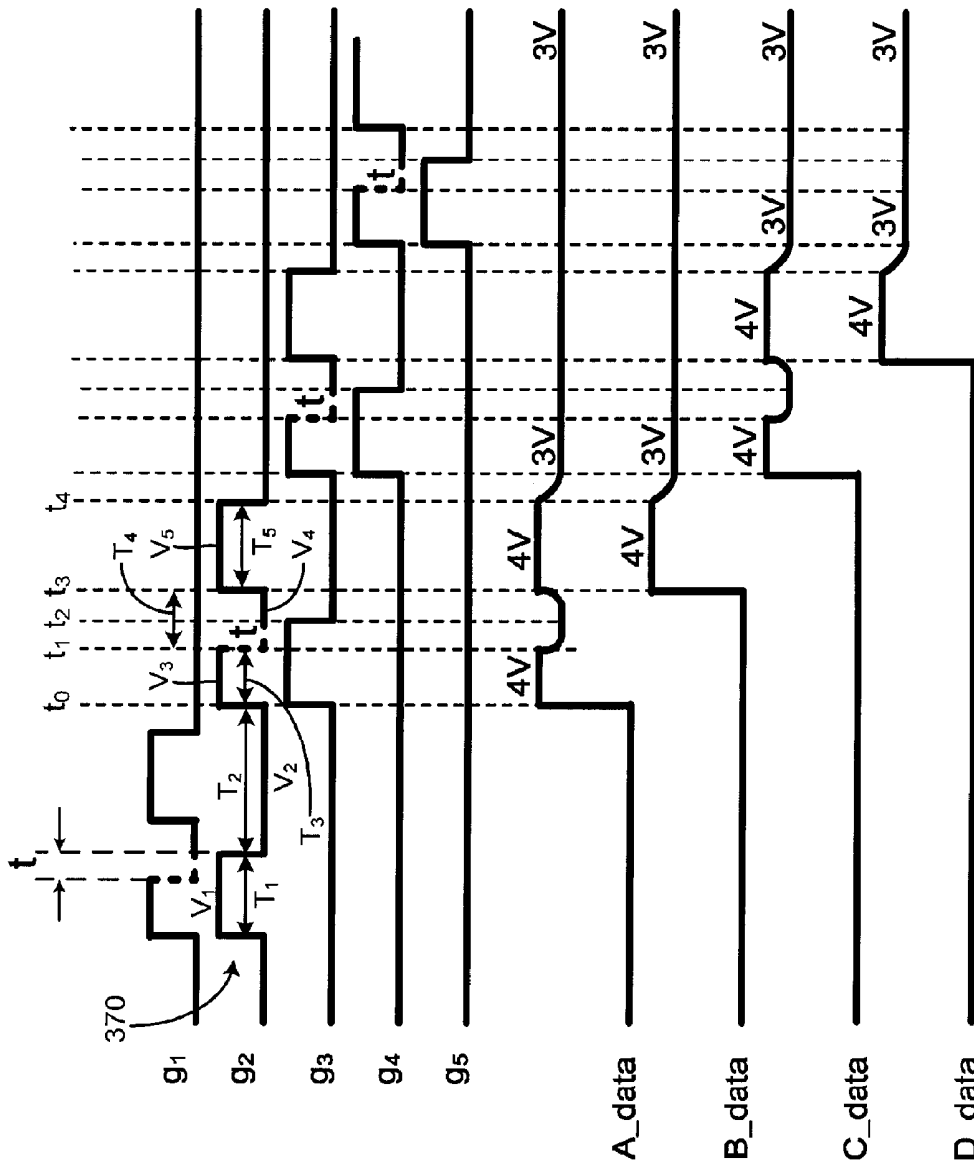

Fig. 8

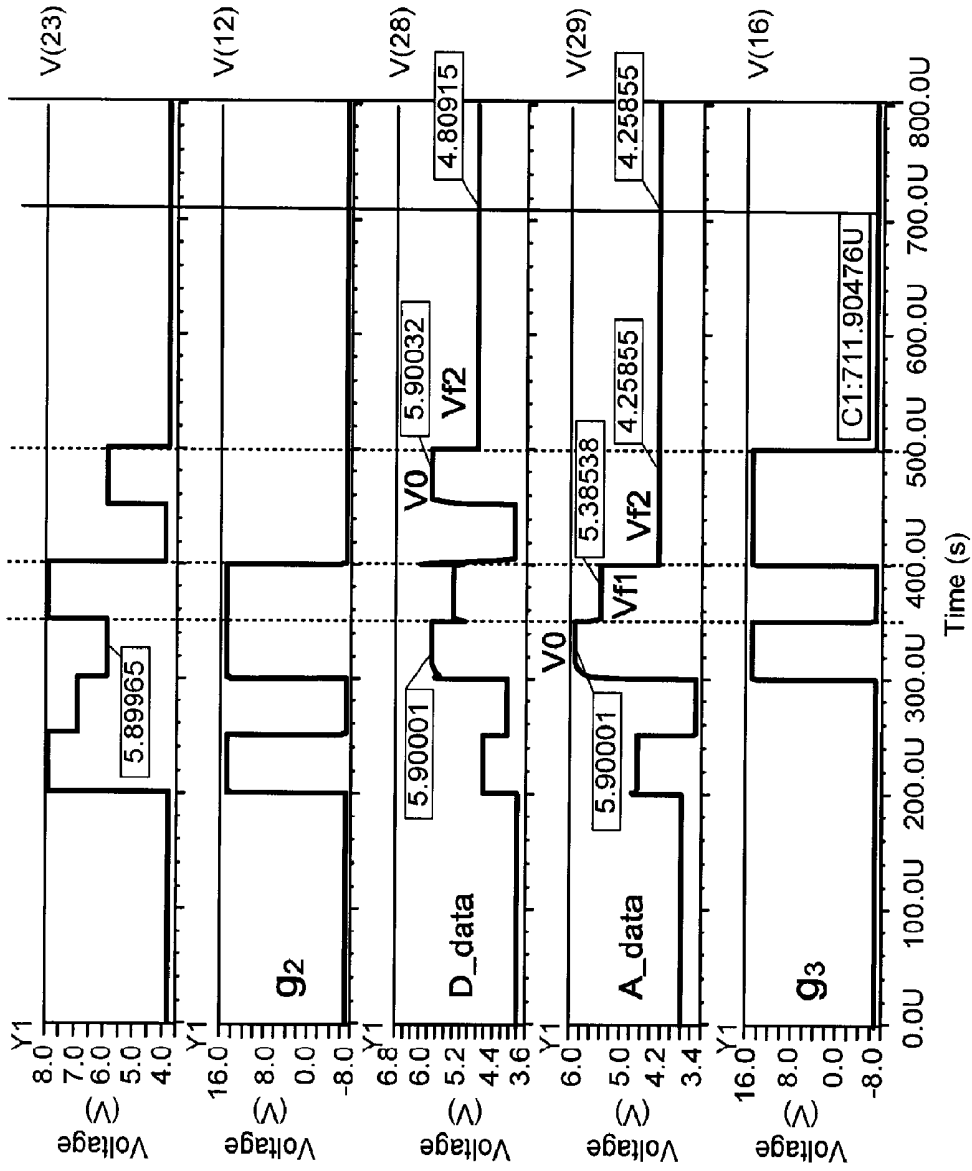

Fig. 10

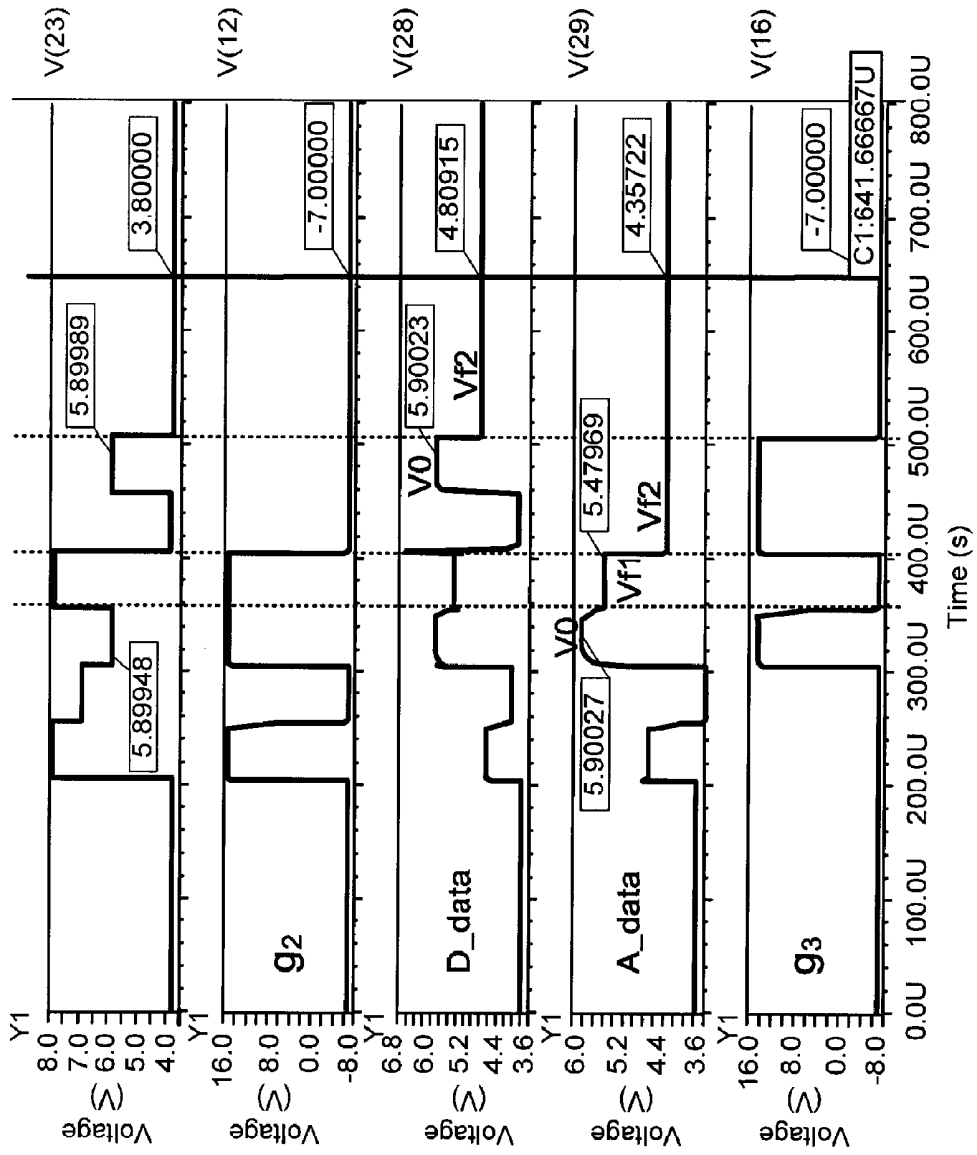

Fig. 11

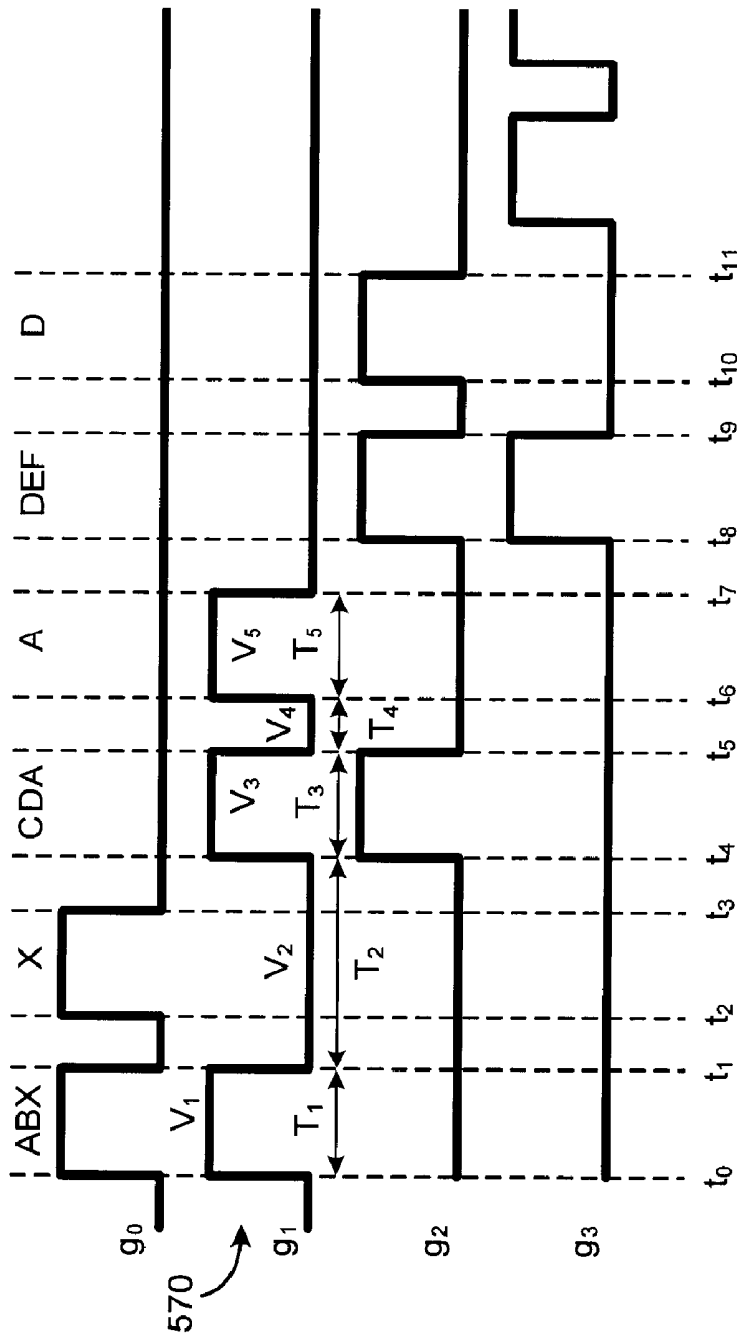

Fig. 12

500

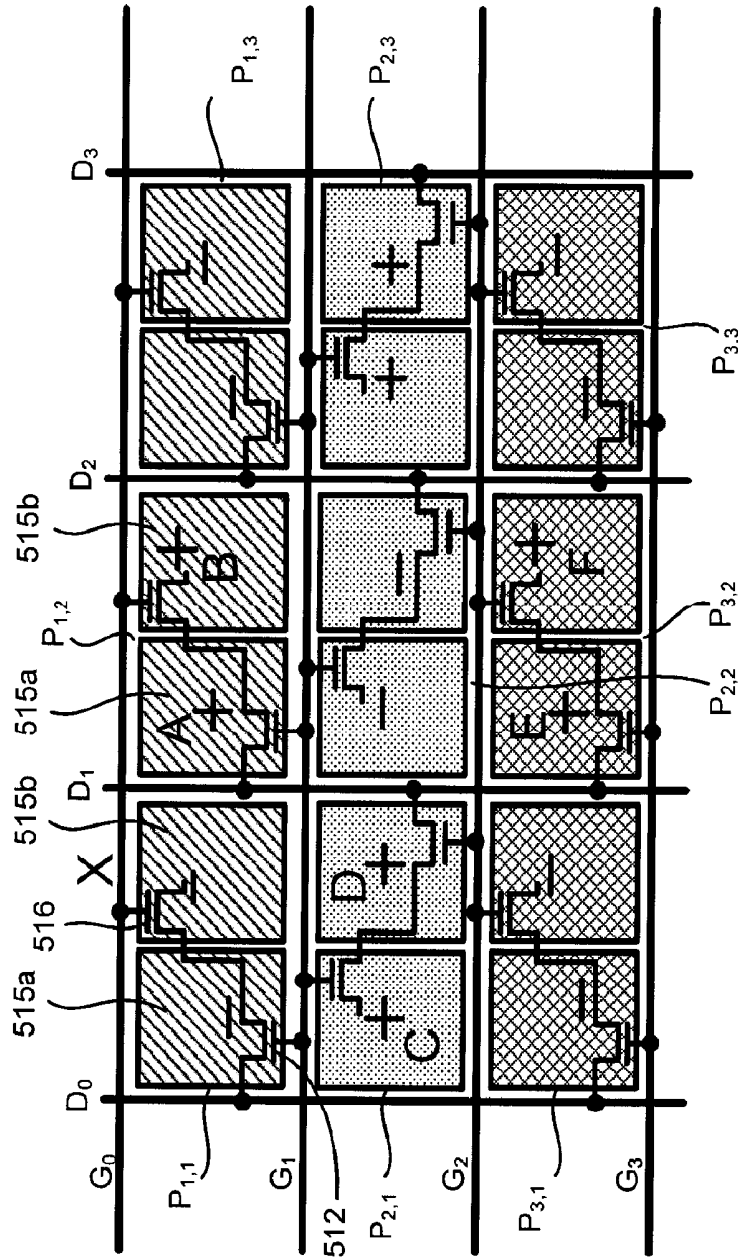

FIG. 13

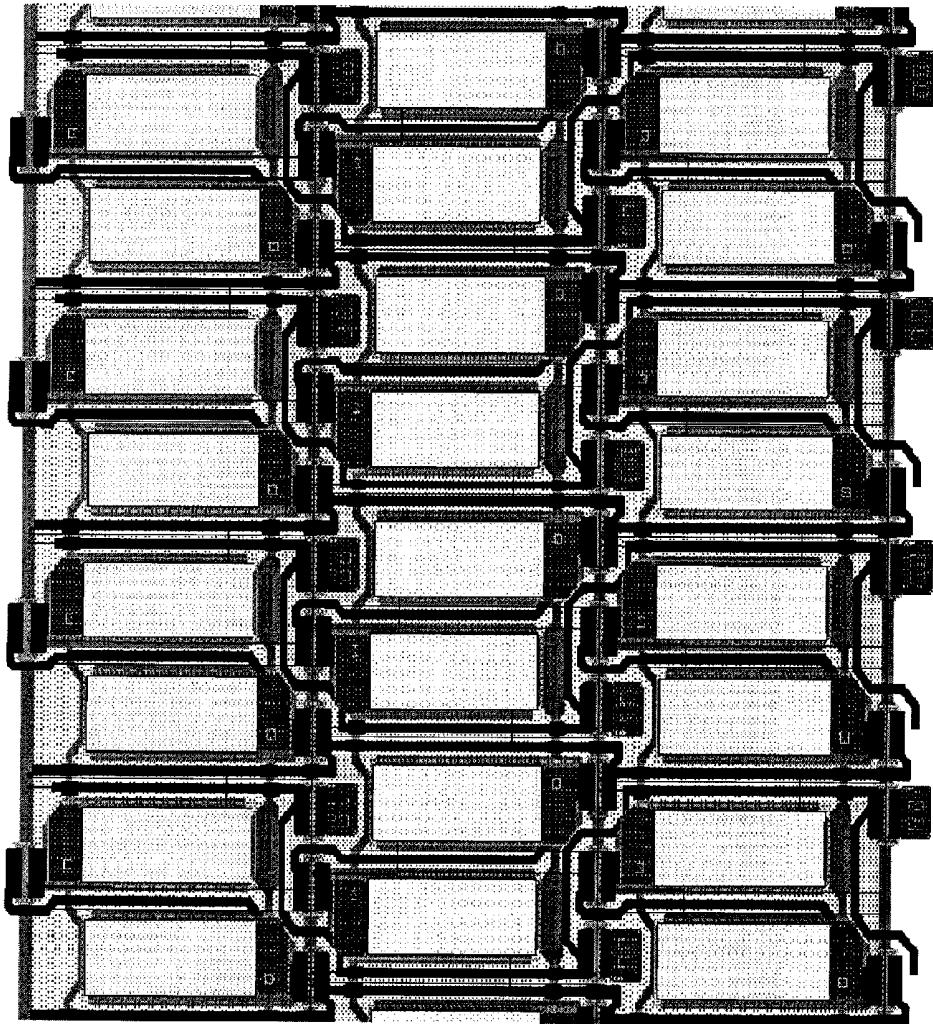

Fig. 15

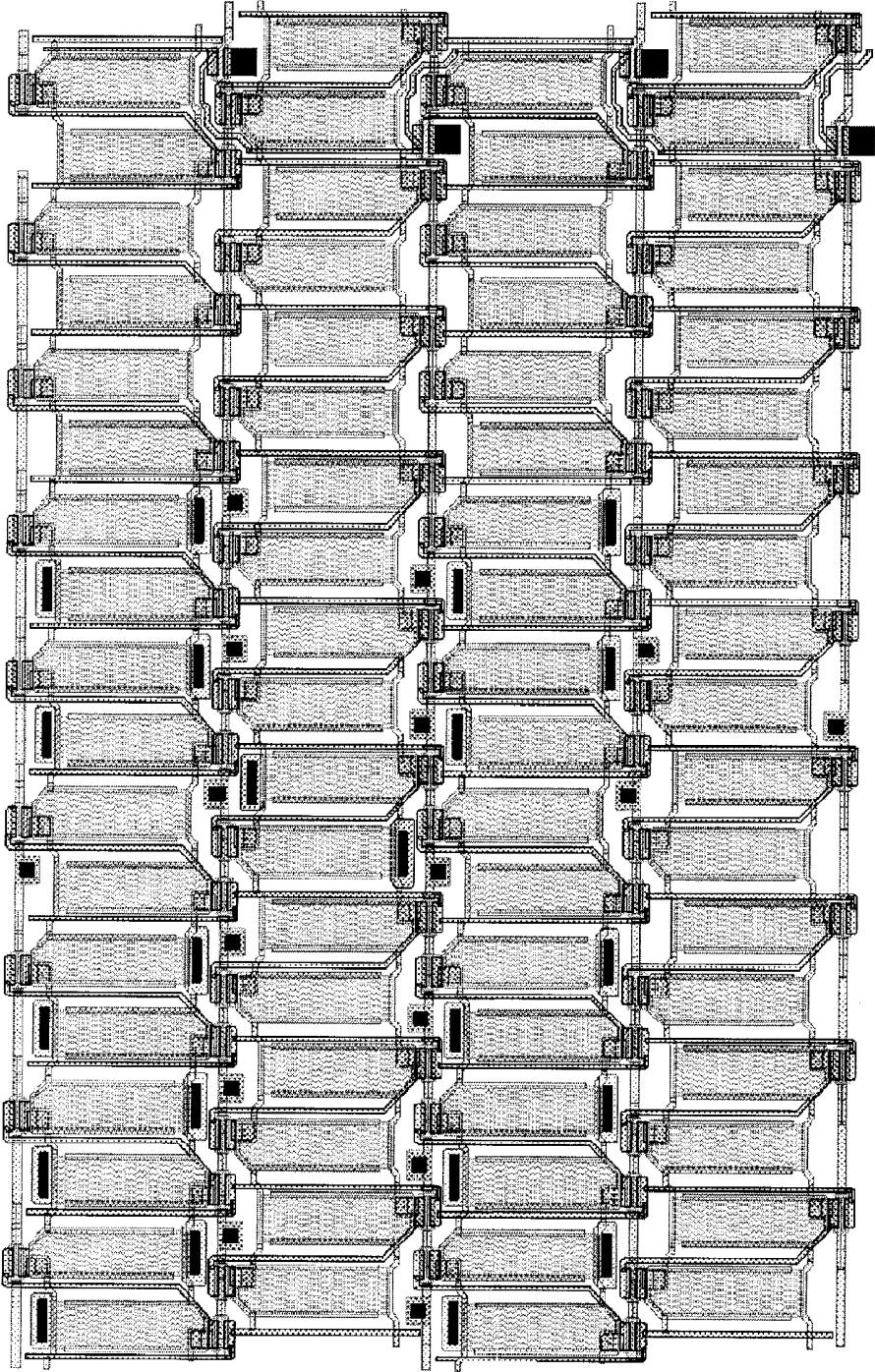

Fig. 16

MULTI SWITCH PIXEL DESIGN USING COLUMN INVERSION DATA DRIVING

FIELD OF THE INVENTION

The present invention relates generally to a liquid crystal display (LCD), and more particularly, to an LCD panel that utilizes a column inversion data driving scheme to reduce power consumption and methods of driving same.

BACKGROUND OF THE INVENTION

A liquid crystal display (LCD) device includes an LCD panel formed with liquid crystal cells and pixel elements with each associating with a corresponding liquid crystal cell and having a liquid crystal (LC) capacitor and a storage capacitor, a thin film transistor (TFT) electrically coupled with the liquid crystal capacitor and the storage capacitor. These pixel elements are substantially arranged in the form of a matrix having a number of pixel rows and a number of pixel columns. Typically, scanning signals are sequentially applied to the number of pixel rows for sequentially turning on the pixel elements row-by-row. When a scanning signal is applied to a pixel row to turn on corresponding TFTs of the pixel elements of a pixel row, source signals (i.e., image signals) for the pixel row are simultaneously applied to the number of pixel columns so as to charge the corresponding liquid crystal capacitor and storage capacitor of the pixel row for aligning orientations of the corresponding liquid crystal cells associated with the pixel row to control light transmittance therethrough. By repeating the procedure for all pixel rows, all pixel elements are supplied with corresponding source signals of the image signal, thereby displaying the image signal thereon.

Liquid crystal molecules have a definite orientational alignment as a result of their long, thin shapes. The orientations of liquid crystal molecules in liquid crystal cells of an LCD panel play a crucial role in the transmittance of light therethrough. It is known if a substantially high voltage potential is applied between the liquid crystal layer for a long period of time, the optical transmission characteristics of the liquid crystal molecules may change. This change may be permanent, causing an irreversible degradation in the display quality of the LCD panel. In order to prevent the LC molecules from being deteriorated, an LCD device is usually driven by using techniques that alternate the polarity of the voltages applied across a LC cell. These techniques may include inversion schemes such as frame inversion, row inversion, column inversion, and dot inversion. Typically, notwithstanding the inversion schemes, a higher image quality requires higher power consumption because of frequent polarity conversions. Such LCD devices, in particular thin film transistor (TFT) LCD devices, may consume significant amounts of power, which may in turn generate excessive heat. The characteristics of the LCD devices will be significantly deteriorated due to the heat generated.

Therefore, a heretofore unaddressed need exists in the art to address the aforementioned deficiencies and inadequacies.

SUMMARY OF THE INVENTION

The present invention, in one aspect, relates to an LCD panel with color washout improvement. In one embodiment, the LCD panel includes a common electrode; a plurality of scanning lines, $\{G_n\}$, $n=1, 2, \dots, N$, N being an integer greater than zero, spatially arranged along a row direction; a plurality of data lines, $\{D_m\}$, $m=1, 2, \dots, M$, M being an integer greater than zero, spatially arranged crossing the plu-

ality of scanning lines $\{G_n\}$ along a column direction perpendicular to the row direction; and a plurality of pixels, $\{P_{n,m}\}$, spatially arranged in the form of a matrix, each pixel $P_{n,m}$ defined between two neighboring scanning lines G_n and G_{n+1} , and two neighboring data lines D_m and D_{m+1} . Each pixel $P_{n,m}$ comprises at least a first sub-pixel, $P_{n,m}(1)$, and a second sub-pixel, $P_{n,m}(2)$. Each of the first sub-pixel and the second sub-pixel includes a sub-pixel electrode, a liquid crystal (LC) capacitor electrically coupled between the sub-pixel electrode and the common electrode in parallel, and a transistor having a gate, a source and a drain electrically coupled to the sub-pixel electrode.

The gate and the source of the transistor of the first sub-pixel $P_{n,m}(1)$ of the pixel $P_{n,m}$ are electrically coupled to the scanning line G_n , and the data line D_m , respectively, and the gate and the source of the transistor of the second sub-pixel $P_{n,m}(2)$ of the pixel $P_{n,m}$ are electrically coupled to the scanning line G_n and the sub-pixel electrode of the first sub-pixel $P_{n,m}(1)$, respectively.

The gate and the source of the transistor of the first sub-pixel $P_{n+1,m}(1)$ of the pixel $P_{n+1,m}$ are electrically coupled to the scanning line G_{n+1} and the sub-pixel electrode **115b** of the second sub-pixel $P_{n+1,m}(2)$, respectively, and the gate and the source **116s** of the transistor of the second sub-pixel $P_{n+1,m}(2)$ of the pixel $P_{n+1,m}$ are electrically coupled to the scanning line G_{n+2} and the data line D_{m+1} , respectively.

In one embodiment, each of the first sub-pixel $P_{n,m}(1)$ and the second sub-pixel $P_{n,m}(2)$ of the pixel $P_{n,m}$ further comprises a storage capacitor electrically coupled between the sub-pixel electrode and the common electrode in parallel.

Additionally, the LCD panel may have a plurality of touch sensing signal lines $\{L_k\}$, $k=1, 2, \dots, K$, K being an integer greater than zero. Each touch sensing signal line is arranged adjacent and parallel to a scanning line G_n or a data line D_m . In one embodiment, each pixel in the even number pixel rows of the pixel matrix or each pixel in the odd number pixel rows of the pixel matrix further comprises a photo sensor (PS) and a transistor having a gate electrically connected to one of two corresponding scanning lines defining the pixel, a source electrically connected the photo sensor and a drain electrically connected to a corresponding touch sensing signal line.

The LCD panel also has a gate driver and a data driver. The gate driver is adapted for generating a plurality of scanning signals respectively applied to the plurality of scanning lines $\{G_n\}$, where the plurality of scanning signals is configured to turn on the transistors connected to the plurality of scanning lines $\{G_n\}$ in a predefined sequence. The data driver is adapted for generating a plurality of data signals respectively applied to the plurality of data lines $\{D_m\}$, where the plurality of data signals is configured such that any two neighboring data signals have inverted polarities.

In one embodiment, each of the plurality of scanning signals is configured to have a waveform. The waveform has a first voltage potential V_1 in a first duration, T_1 , a second voltage potential V_2 in a second duration, T_2 , a third voltage potential V_3 in a third duration, T_3 , a fourth voltage potential V_4 in a fourth duration, T_4 , and a fifth voltage potential V_5 in a fifth duration, T_5 , where the $(+1)$ -th duration T_{j+1} is immediately after the j -th duration T_j , $j=1, 2, 3$ and 4 , and $V_1=V_3=V_5>V_2=V_4$, $T_2=(T_1+2t)$, $T_3=(T_1-t)$, $T_4=2t$, $T_5=T_1$, and $T_1>>t$. The waveform of each of the scanning signals is sequentially shifted from one another by a duration of T_1+T_2 .

In another embodiment, each of the plurality of scanning signals is configured to have a waveform, where the waveform of each of the plurality of scanning signals has a first voltage potential $V_1(t)$ in a first duration, T_1 , a second voltage potential $V_2(t)$ in a second duration, T_2 , and a third voltage

potential $V_3(t)$ in a third duration, T_3 . The second duration T_2 is immediately after the first duration T_1 , and the third duration T_3 is immediately after the second duration T_2 . $V_1(t)$ and $V_3(t)$ vary with time and $V_2(t)=V_2$ is a constant and independent of time. The first duration T_1 includes a first time period, T_0 , and a second time period, $T=(T_1-T_0)$, immediately after the first time period T_0 , where in the first time period T_0 , $V_1(t)=V_1$, a constant voltage potential, and $V_1(t)$ continuously decreases from V_1 to V_0 as time goes in the second time period T . The third duration T_3 includes a first time period, T_0 , a second time period, T , immediately after the first time period T_0 , and a third time period $(T_3-T_1-T_0)$, immediately after the second time period T , where $V_3(t)=V_3$, a constant voltage potential, in the first time period T_0 , $V_3(t)$ continuously decreases from V_3 to V_0 as time goes in the second time period T , and $V_3(t)=V_3$ in the third time period, and where $V_1=V_3>V_2$, $V_1>V_0\geq V_2$, $T_1=T_2$, and $T_3=2T_1$. The waveform of each of the scanning signals is sequentially shifted from one another by a duration of T_1+T_2 .

In such a driving scheme, in operation, the plurality of pixels $\{P_{n,m}\}$ has a pixel polarity that is in a dot inversion.

In one embodiment, each of the transistors is a field-effect thin film transistor (TFT).

In another aspect, the present invention relates to a method of driving a liquid crystal display (LCD). In one embodiment, the method includes the steps of providing an LCD panel. The LCD panel has a common electrode, a plurality of scanning lines, $\{G_n\}$, $n=1, 2, \dots, N$, N being an integer greater than zero, spatially arranged along a row direction, a plurality of data lines, $\{D_m\}$, $m=1, 2, \dots, M$, M being an integer greater than zero, spatially arranged crossing the plurality of scanning lines $\{G_n\}$ along a column direction perpendicular to the row direction, and a plurality of pixels, $\{P_{n,m}\}$, spatially arranged in the form of a matrix.

Each pixel $P_{n,m}$ is defined between two neighboring scanning lines G_n and G_{n+1} and two neighboring data lines D_m and D_{m+1} , and has at least a first sub-pixel, $P_{n,m}(1)$, and a second sub-pixel, $P_{n,m}(2)$. Each of the first sub-pixel and the second sub-pixel comprises a sub-pixel electrode, a liquid crystal (LC) capacitor electrically coupled between the sub-pixel electrode and the common electrode in parallel, and a transistor having a gate, a source and a drain electrically coupled to the sub-pixel electrode. The gate and the source of the transistor of the first sub-pixel $P_{n,m}(1)$ of the pixel $P_{n,m}$ are electrically coupled to the scanning line G_{n+1} and the data line D_m , respectively. The gate and the source of the transistor of the second sub-pixel $P_{n,m}(2)$ of the pixel $P_{n,m}$ are electrically coupled to the scanning line G_n and the sub-pixel electrode of the first sub-pixel $P_{n,m}(1)$, respectively. The gate and the source of the transistor of the first sub-pixel $P_{n+1,m}(1)$ of the pixel $P_{n+1,m}$ are electrically coupled to the scanning line G_{n+1} and the sub-pixel electrode of the second sub-pixel $P_{n+1,m}(2)$, respectively. The gate and the source of the transistor of the second sub-pixel $P_{n+1,m}(2)$ of the pixel $P_{n+1,m}$ are electrically coupled to the scanning line G_{n+2} and the data line D_{m+1} , respectively.

Additionally, the LCD panel may have a plurality of touch sensing signal lines $\{L_k\}$, $k=1, 2, \dots, K$, K being an integer greater than zero. Each touch sensing signal line is arranged adjacent and parallel to a scanning line G_n or a data line D_m . In one embodiment, each pixel in the even number pixel rows of the pixel matrix or each pixel in the odd number pixel rows of the pixel matrix further comprises a photo sensor (PS) and a transistor having a gate electrically connected to one of two corresponding scanning lines defining the pixel, a source electrically connected the photo sensor and a drain electrically connected to a corresponding touch sensing signal line.

The method further includes the step of applying a plurality of scanning signals to the plurality of scanning lines $\{G_n\}$ and a plurality of data signals to the plurality of data lines $\{D_m\}$, respectively. The plurality of scanning signals is configured to turn on the transistors connected to the plurality of scanning lines $\{G_n\}$ in a predefined sequence, and the plurality of data signals is configured such that any two neighboring data signals have inverted polarities. Accordingly, the plurality of pixels $\{P_{n,m}\}$ in operation has a pixel polarity that is in a dot inversion.

In yet another aspect, the present invention relates to a liquid crystal display (LCD) panel. In one embodiment, the LCD panel has a plurality of pixels, $\{P_{n,m}\}$, spatially arranged in the form of a matrix, $n=1, 2, \dots, N$, and $m=1, 2, \dots, M$, and N, M being an integer greater than zero. Each pixel $P_{n,m}$ has at least a first sub-pixel, $P_{n,m}(1)$ and a second sub-pixel, $P_{n,m}(2)$, where each of the first sub-pixel $P_{n,m}(1)$ and the second sub-pixel $P_{n,m}(2)$ comprises a sub-pixel electrode and a switching element electrically coupled to the sub-pixel electrode.

The LCD panel also has a plurality of scanning lines, $\{G_n\}$, spatially arranged along a row direction. Each pair of two neighboring scanning lines G_n and G_{n+1} defines a pixel row $P_{n,\{m\}}$ of the pixel matrix $\{P_{n,m}\}$ therebetween and is electrically coupled to the switching elements of the first sub-pixel and the second sub-pixel of each pixel in the pixel row $P_{n,\{m\}}$, respectively.

The LCD panel further has a plurality of data lines, $\{D_m\}$, spatially arranged crossing the plurality of scanning lines $\{G_n\}$ along a column direction perpendicular to the row direction. Each pair of two neighboring data lines D_m and D_{m+1} defines a pixel column, $P_{\{n\},m}$, of the pixel matrix $\{P_{n,m}\}$ therebetween. Each data line D_m is electrically coupled to the switching element of the first sub-pixel or the second sub-pixel of each odd pixel of one of two neighboring pixel columns $P_{\{n\},m-1}$ and $P_{\{n\},m}$ associated with the data line D_m and to the switching element of the second sub-pixel or the first sub-pixel of each even pixel of the other of the two neighboring pixel columns $P_{\{n\},m-1}$ and $P_{\{n\},m}$.

Additionally, the LCD panel may also have at least one common electrode. In one embodiment, each of the first sub-pixel $P_{n,m}(1)$ and the second sub-pixel $P_{n,m}(2)$ of the pixel $P_{n,m}$ of the pixel matrix $\{P_{n,m}\}$ further comprises an LC capacitor and a storage capacitor both electrically coupled between the sub-pixel electrode and the common electrode in parallel.

Furthermore, the LCD panel has a gate driver for generating a plurality of scanning signals respectively applied to the plurality of scanning lines $\{G_n\}$, where the plurality of scanning signals is configured to turn on the switching elements connected to the plurality of scanning lines $\{G_n\}$ in a predefined sequence; and a data driver for generating a plurality of data signals respectively applied to the plurality of data lines $\{D_m\}$, where the plurality of data signals is configured such that any two neighboring data signals have inverted polarities. In operation, the plurality of pixels $\{P_{n,m}\}$ has a pixel polarity that is in a dot inversion.

In one embodiment, each of the switching elements of the first sub-pixel $P_{n,m}(1)$ and the second sub-pixel $P_{n,m}(2)$ of the pixel $P_{n,m}$ of the pixel matrix $\{P_{n,m}\}$ is a field-effect thin film transistor having a gate, a source and a drain. In one embodiment, the drain of the transistor of each of the first sub-pixel $P_{n,m}(1)$ and the second sub-pixel $P_{n,m}(2)$ of the pixel $P_{n,m}$ of the pixel matrix $\{P_{n,m}\}$ is electrically coupled to the sub-pixel electrode of the corresponding sub-pixel. The gate and the source of the transistor of the first sub-pixel $P_{n,m}(1)$ of the pixel $P_{n,m}$ of the pixel matrix $\{P_{n,m}\}$ are electrically coupled

to the scanning line G_{n+1} and the data line D_m , respectively. The gate and the source of the transistor of the second sub-pixel $P_{n,m}(2)$ of the pixel $P_{n,m}$ of the pixel matrix $\{P_{n,m}\}$ are electrically coupled to the scanning line G_n and the sub-pixel electrode of the first sub-pixel $P_{n,m}(1)$, respectively. The gate and the source of the transistor of the first sub-pixel $P_{n+1,m}(1)$ of the pixel $P_{n+1,m}$ of the pixel matrix $\{P_{n,m}\}$ are electrically coupled to the scanning line G_{n+1} and the sub-pixel electrode of the second sub-pixel $P_{n+1,m}(2)$, respectively. The gate and the source of the transistor of the second sub-pixel $P_{n+1,m}(2)$ of the pixel $P_{n+1,m}$ of the pixel matrix $\{P_{n,m}\}$ are electrically coupled to the scanning line G_{n+2} and the data line D_{m+1} , respectively.

Additionally, the LCD panel may have a plurality of touch sensing signal lines $\{L_k\}$, $k=1, 2, \dots, K$, K being an integer greater than zero. Each touch sensing signal line is arranged adjacent and parallel to a scanning line G_n or a data line D_m . In one embodiment, each pixel in the even number pixel rows of the pixel matrix or each pixel in the odd number pixel rows of the pixel matrix further comprises a photo sensor (PS) and a transistor having a gate electrically connected to one of two corresponding scanning lines defining the pixel, a source electrically connected the photo sensor and a drain electrically connected to a corresponding touch sensing signal line.

In a further aspect, the present invention relates to a method of driving an LCD. In one embodiment, the method includes the steps of providing an LCD panel. The LCD panel in one embodiment, has a plurality of pixels, $\{P_{n,m}\}$, spatially arranged in the form of a matrix, $n=1, 2, \dots, N$, and $m=1, 2, \dots, M$, and N, M being an integer greater than zero. Each pixel $P_{n,m}$ has at least a first sub-pixel, $P_{n,m}(1)$ and a second sub-pixel, $P_{n,m}(2)$. Each of the first sub-pixel $P_{n,m}(1)$ and the second sub-pixel $P_{n,m}(2)$ comprises a sub-pixel electrode and a switching element electrically coupled to the sub-pixel electrode.

The LCD panel also has a plurality of scanning lines, $\{G_n\}$, spatially arranged along a row direction, and a plurality of data lines, $\{D_m\}$, spatially arranged crossing the plurality of scanning lines $\{G_n\}$ along a column direction perpendicular to the row direction. Each pair of two neighboring scanning lines G_n and G_{n-1} defines a pixel row $P_{n,\{m\}}$ of the pixel matrix $\{P_{n,m}\}$ therebetween and is electrically coupled to the switching elements of the first sub-pixel and the second sub-pixel of each pixel in the pixel row $P_{n,\{m\}}$, respectively. Each pair of two neighboring data lines D_m and D_{m+1} defines a pixel column, $P_{\{n\},m}$, of the pixel matrix $\{P_{n,m}\}$ therebetween. Each data line D_m is electrically coupled to the switching element of the first sub-pixel or the second sub-pixel of each odd pixel of one of two neighboring pixel columns $P_{\{n\},m-1}$ and $P_{\{n\},m}$ associated with the data line D_m and to the switching element of the second sub-pixel or the first sub-pixel of each even pixel of the other of the two neighboring pixel columns $P_{\{n\},m-1}$ and $P_{\{n\},m}$.

In one embodiment, the LCD panel further comprises at least one common electrode. Each of the first sub-pixel $P_{n,m}(1)$ and the second sub-pixel $P_{n,m}(2)$ of the pixel $P_{n,m}$ of the pixel matrix $\{P_{n,m}\}$ further comprises an LC capacitor and a storage capacitor both electrically coupled between the sub-pixel electrode and the common electrode in parallel.

In one embodiment, each of the switching elements of the first sub-pixel $P_{n,m}(1)$ and the second sub-pixel $P_{n,m}(1)$ of the pixel $P_{n,m}$ of the pixel matrix $\{P_{n,m}\}$ is a field-effect thin film transistor having a gate, a source and a drain. The drain of the transistor of each of the first sub-pixel $P_{n,m}(1)$ and the second sub-pixel $P_{n,m}(2)$ of each pixel $P_{n,m}$ of the pixel matrix $\{P_{n,m}\}$ is electrically coupled to the sub-pixel electrode of the corresponding sub-pixel. The gate and the source of the transistor

of the first sub-pixel $P_{n,m}(1)$ of the pixel $P_{n,m}$ of the pixel matrix $\{P_{n,m}\}$ are electrically coupled to the scanning line G_{n+1} and the data line D_m , respectively. The gate and the source of the transistor of the second sub-pixel $P_{n,m}(2)$ of the pixel $P_{n,m}$ of the pixel matrix $\{P_{n,m}\}$ are electrically coupled to the scanning line G_n and the sub-pixel electrode of the first sub-pixel $P_{n,m}(1)$, respectively. The gate and the source of the transistor of the first sub-pixel $P_{n+1,m}(1)$ of the pixel $P_{n+1,m}$ of the pixel matrix $\{P_{n,m}\}$ are electrically coupled to the scanning line G_{n+1} and the sub-pixel electrode of the second sub-pixel $P_{n+1,m}(2)$, respectively. The gate and the source of the transistor of the second sub-pixel $P_{n+1,m}(2)$ of the pixel $P_{n+1,m}$ of the pixel matrix $\{P_{n,m}\}$ are electrically coupled to the scanning line G_{n+2} and the data line D_{m+1} , respectively.

Additionally, the LCD panel may have a plurality of touch sensing signal lines $\{L_k\}$, $k=1, 2, \dots, K$, K being an integer greater than zero. Each touch sensing signal line is arranged adjacent and parallel to a scanning line G_n or a data line D_m . In one embodiment, each pixel in the even number pixel rows of the pixel matrix or each pixel in the odd number pixel rows of the pixel matrix further comprises a photo sensor (PS) and a transistor having a gate electrically connected to one of two corresponding scanning lines defining the pixel, a source electrically connected the photo sensor and a drain electrically connected to a corresponding touch sensing signal line.

Furthermore, the method includes the step of applying a plurality of scanning signals to the plurality of scanning lines $\{G_n\}$ and a plurality of data signals to the plurality of data lines $\{D_m\}$, respectively. The plurality of scanning signals is configured to turn on the switching elements connected to the plurality of scanning lines $\{G_n\}$ in a predefined sequence, and the plurality of data signals is configured such that any two neighboring data signals have inverted polarities. Accordingly, the plurality of pixels $\{P_{n,m}\}$ in operation has a pixel polarity that is in a dot inversion.

These and other aspects of the present invention will become apparent from the following description of the preferred embodiment taken in conjunction with the following drawings, although variations and modifications therein may be affected without departing from the spirit and scope of the novel concepts of the disclosure.

BRIEF DESCRIPTION OF THE DRAWINGS

The accompanying drawings illustrate one or more embodiments of the invention and, together with the written description, serve to explain the principles of the invention. Wherever possible, the same reference numbers are used throughout the drawings to refer to the same or like elements of an embodiment, wherein:

FIG. 1 shows schematically a partially equivalent circuit diagram of an LCD panel according to one embodiment of the present invention;

FIG. 2 shows schematically another partially equivalent circuit diagram of the LCD panel shown in FIG. 1;

FIG. 3 shows schematically the equivalent circuit diagram of the LCD panel shown in FIG. 1, with a gate driver and a data driver;

FIG. 4 shows time charts of driving signals applied to the LCD panel shown in FIG. 1;

FIG. 5 shows schematically a partial layout view of the LCD panel shown in FIG. 1;

FIG. 6 shows schematically another partial layout view of the LCD panel shown in FIG. 1;

FIG. 7 shows time charts of the scanning signals shown in FIG. 4 and corresponding pixel voltage potentials of the LCD panel shown in FIG. 6;

FIG. 8 shows time charts of scanning signals according to one embodiment of the present invention and corresponding pixel voltage potentials of the LCD panel shown in FIG. 6;

FIG. 9 shows time charts of scanning signals according to another embodiment of the present invention and corresponding pixel voltage potentials of the LCD panel shown in FIG. 6;

FIG. 10 shows simulation results of the pixel voltage potentials of the LCD panel for the scanning signals shown in FIG. 7;

FIG. 11 shows simulation results of the pixel voltage potentials of the LCD panel for the scanning signals shown in FIG. 9;

FIG. 12 shows time charts of scanning signals according to one embodiment of the present invention;

FIG. 13 shows schematically a partial layout view of the LCD panel shown in FIG. 1;

FIG. 14 shows schematically a partially equivalent circuit diagram of an LCD panel according to one embodiment of the present invention;

FIG. 15 shows schematically a partial layout view of the LCD panel shown in FIG. 14; and

FIG. 16 shows schematically another partial layout view of the LCD panel shown in FIG. 14.

DETAILED DESCRIPTION OF THE INVENTION

The present invention is more particularly described in the following examples that are intended as illustrative only since numerous modifications and variations therein will be apparent to those skilled in the art. Various embodiments of the invention are now described in detail. Referring to the drawings, like numbers indicate like components throughout the views. As used in the description herein and throughout the claims that follow, the meaning of “a”, “an”, and “the” includes plural reference unless the context clearly dictates otherwise. Also, as used in the description herein and throughout the claims that follow, the meaning of “in” includes “in” and “on” unless the context clearly dictates otherwise. Additionally, some terms used in this specification are more specifically defined below.

The description will be made as to the embodiments of the present invention in conjunction with the accompanying drawings in FIGS. 1-16. In accordance with the purposes of this invention, as embodied and broadly described herein, this invention, in one aspect, relates to an LCD panel that utilizes a column inversion data driving scheme to reduce power consumption and methods of driving same.

Referring to FIGS. 1-3, an LCD panel 100 according to one embodiment of the present invention is partially and schematically shown. The LCD panel 100 includes a common electrode 160, a plurality of scanning lines, $G_1, G_2, \dots, G_n, G_{n+1}, G_{n+2}, G_{n+3}, \dots, G_N$, that are spatially arranged along a row (scanning) direction 130, and a plurality of data lines, $D_1, D_2, \dots, D_m, D_{m+1}, D_{m+2}, D_{m+3}, \dots, D_M$, that are spatially arranged crossing the plurality of scanning lines $G_1, G_2, \dots, G_n, G_{n+1}, G_{n+2}, G_{n+3}, \dots, G_N$ along a column direction 140 that is perpendicular to the row direction 130. N and M are integers greater than one. The LCD panel 100 further has a plurality of pixels, $\{P_{n,m}\}$, that is spatially arranged in the form of a matrix. Each pixel $P_{n,m}$ is defined between two neighboring scanning lines G_n and G_{n+1} and two neighboring data lines D_m and D_{m+1} . For the purpose of illustration of embodiments of the present invention, FIG. 1 schematically shows only four scanning lines G_n, G_{n+1}, G_{n+2} and G_{n+3} , four data lines D_m, D_{m+1}, D_{m+2} and D_{m+3} , and nine corresponding pixels of the LCD panel 100. FIG. 2 schematically shows only

three scanning lines G_n, G_{n+1} and G_{n+2} , two data lines D_m and D_{m+1} , and two corresponding pixels $P_{n,m}$ and $P_{n+1,m}$ of the LCD panel 100.

Furthermore, each pixel $P_{n,m}$ is configured to have two or more sub-pixels. As shown in FIG. 2, a pixel $P_{n,m}$ located, for example, between two neighboring scanning lines G_n and G_{n+1} and two neighboring data lines D_m and D_{m+1} crossing the two neighboring scanning lines G_n and G_{n+1} , has a first sub-pixel, $P_{n,m}(1)$, and a second sub-pixel, $P_{n,m}(2)$. Each of the first sub-pixel $P_{n,m}(1)$ and the second sub-pixel $P_{n,m}(2)$ comprises a sub-pixel electrode 115a/115b, a liquid crystal (LC) capacitor 113a/113b and a transistor 112/116 having a gate 112g/116g, a source 112s/116s and a drain 112d/116d.

The LC capacitor 113a of the first sub-pixel $P_{n,m}(1)$ of the pixel $P_{n,m}$ is electrically connected between the sub-pixel electrode 115a of the first sub-pixel $P_{n,m}(1)$ of the pixel $P_{n,m}$ and the common electrode 160 in parallel. The LC capacitor 113b of the second sub-pixel $P_{n,m}(2)$ of the pixel $P_{n,m}$ is electrically connected between the sub-pixel electrode 115b of the second sub-pixel $P_{n,m}(2)$ of the pixel $P_{n,m}$ and the common electrode 160 in parallel. Additionally, each of the first sub-pixel $P_{n,m}(1)$ and the second sub-pixel $P_{n,m}(2)$ of the pixel $P_{n,m}$ may have a storage capacitor electrically connected between the sub-pixel electrode 115a/115b of the corresponding sub-pixel $P_{n,m}(1)/P_{n,m}(2)$ of the pixel $P_{n,m}$ and the common electrode 160 in parallel (not shown), for providing coupling voltages to the corresponding LC capacitor 113a/113b to compensate for charge leakages therefrom.

The gate 112g and the source 112s of the transistor 112 of the first sub-pixel $P_{n,m}(1)$ of the pixel $P_{n,m}$ are electrically coupled to the scanning line G_{n+1} and the data line D_m , respectively, and the gate 116g and the source 116s of the transistor 116 of the second sub-pixel $P_{n,m}(2)$ of the pixel $P_{n,m}$ are electrically coupled to the scanning line G_n and the sub-pixel electrode 115a of the first sub-pixel $P_{n,m}(1)$, respectively.

The gate 112g and the source 112s of the transistor 112 of the first sub-pixel $P_{n+1,m}(1)$ of the pixel $P_{n+1,m}$ are electrically coupled to the scanning line G_{n+1} and the sub-pixel electrode 115b of the second sub-pixel $P_{n+1,m}(2)$, respectively, and the gate 116g and the source 116s of the transistor 116 of the second sub-pixel $P_{n+1,m}(2)$ of the pixel $P_{n+1,m}$ are electrically coupled to the scanning line G_{n+2} and the data line D_{m+1} , respectively.

In one embodiment, the sub-pixel electrodes 115a/115b of the first sub-pixel $P_{n,m}(1)$ and the second sub-pixel $P_{n,m}(2)$ of each pixel $P_{n,m}$ are deposited on a first substrate (not shown), while the common electrode 160 is deposited on a second substrate (not shown) that is spatially apart from the first substrate. The LC molecules are filled into cells between the first and second substrates. Each cell is associated with a pixel $P_{n,m}$ of the LCD panel 100. Voltages (potentials) applied to the sub-pixel electrodes control orientational alignments of the LC molecules in the LC cells associated with the corresponding sub-pixels.

The transistor 112 and the transistor 116 in one embodiment are field-effect TFTs and adapted for activating the first sub-pixel $P_{n,m}(1)$ and the second sub-pixel $P_{n,m}(2)$, respectively. Other types of transistors may also be utilized to practice the present invention. When the transistor 112 and the transistor 116 are selected to be turned on by a scanning signal applied through the scanning line G_n or the scanning line G_{n+1} to which the gate 112g of the transistor 112 and the gate 116g of the transistor 116 are electrically coupled, a data signal applied through the corresponding data line D_m or the corresponding data line D_{m+1} is incorporated into the first sub-pixel $P_{n,m}(1)$ and the second sub-pixel $P_{n,m}(2)$ by means of

charging the corresponding LC capacitors **113a** and **113b** of the first sub-pixel $P_{n,m}(1)$ and the second sub-pixel $P_{n,m}(2)$, respectively. The charged potentials of the LC capacitors **113a** and **113b** of the first sub-pixel $P_{n,m}(1)$ and the second sub-pixel $P_{n,m}(2)$ of the pixel $P_{n,m}$ are corresponding to the electrical fields applied to corresponding liquid crystal cells between the first and second substrates.

The LCD panel **100** further has a gate driver **152** and a data driver **154**, as shown in FIG. 3. The gate driver **152** is adapted for generating a plurality of scanning signals, $\{g_n\}$, respectively applied to the plurality of scanning lines $\{G_n\}$. The plurality of scanning signals $\{g_n\}$ is configured to turn on the transistors **112/116** connected to the plurality of scanning lines $\{G_n\}$ in a predefined sequence. The data driver **154** is adapted for generating a plurality of data signals, $\{d_m\}$, respectively applied to the plurality of data lines $\{D_m\}$. The plurality of data signals $\{d_m\}$ is configured such that any two neighboring data signals d_m and d_{m+1} have inverted polarities, i.e., if the data signal d_m has a positive/high voltage, then the data signal d_{m+1} has a negative/low voltage, and vice versus.

For such a pixel arrangement and a driving scheme, data of an image to be displayed is applied to the plurality of data lines $\{D_m\}$ in the column inversion, while the image display in the plurality of pixels $\{P_{n,m}\}$ is in the dot inversion, which has high quality of display. Because each data line D_m is electrically coupled to both the pixel column $P_{\{n\},m}$ and its neighboring pixel column $P_{\{n\},m+1}$, only half number of data lines $\{D_m\}$ may be needed in order to achieve the dot inversion in the LCD panel **100**, comparing to that of a conventional LCD panel of the dot inversion. Accordingly, the LCD panel **100** may save as much as half of power consumption of the conventional LCD panel of the dot inversion.

Referring to FIGS. 4 and 5, waveform charts of the driving signals applied to the LCD panel **200** and charging in the corresponding sub-pixel electrodes **215a** and **215b** of the LCD panel **200** are shown according to one embodiment of the present invention. In the exemplary embodiment, the LCD panel **200** is shown schematically and partially with 3×3 pixels, where the pixels, for example, in the first column of the 3×3 pixel matrix are referenced by $P_{0,0}$, $P_{1,0}$ and $P_{2,0}$, respectively. Each pixel has a first sub-pixel electrode **215a**, a second sub-pixel electrode **215b**, a first transistor (switching device) **212** and a second transistor (switching device) **216**, each transistor **212** or **216** having a gate, a source and a drain. The gates of both the first transistor **212** and the second transistor **216** of each pixel are electrically connected to a pair of two neighboring scanning lines, respectively, by which the pixel is defined, such as G_0 and G_1 , G_1 and G_2 or G_2 and G_3 . The drains of the first transistor **212** and the second transistor **216** of each pixel are electrically connected to the first sub-pixel electrode **215a** and the second sub-pixel electrode **215b** of the pixel, respectively.

For the pixels $P_{0,0}$, $P_{0,1}$ and $P_{0,2}$ of the first pixel row defined by the pair of two neighboring scanning lines G_0 and G_1 , the source of the first transistor **212** of each pixel $P_{0,0}$, $P_{0,1}$ or $P_{0,2}$ is electrically connected to a corresponding data line D_0 , D_1 or D_2 , while the source of the second transistor **216** of each pixel $P_{0,0}$, $P_{0,1}$ or $P_{0,2}$ is electrically connected to the first sub-electrode **215a** of the pixel. However, for the pixels $P_{1,0}$, $P_{1,1}$ and $P_{1,2}$ of the second pixel row defined by the pair of two neighboring scanning lines G_1 and G_2 , the source of the first transistor **212** of each pixel $P_{1,0}$, $P_{1,1}$, or $P_{1,2}$ is electrically connected to the second sub-electrode **215b** of the pixel, while the source of the second transistor **216** of each pixel $P_{0,0}$, $P_{0,1}$ or $P_{0,2}$ is electrically connected to a corresponding data line D_1 , D_2 or D_3 . The pixel arrangement repeats in every

two neighboring pixel rows, as shown in FIG. 5. The scanning line G_0 and the data line D_0 are usually adapted for inputting dummy signals therein.

In the exemplary embodiment, the driving signals include three scanning signals g_1 (**271**), g_2 (**272**) and g_3 (**273**) respectively applied to the scanning lines G_1 , G_2 and G_3 , and two data signals d_1 (**281**) and d_2 (**282**) respectively applied to the data lines D_1 and D_2 , and a common signal V_{com} (**290**) applied to the common electrode (not shown), respectively. The scanning signals **271**, **272** and **273** are generated by a gate driver. Each of the scanning signals **271**, **272** and **273** has a waveform **270**. The waveform **270** has a first voltage potential V_1 in a first duration, T_1 , a second voltage potential V_2 in a second duration, T_2 , and a third voltage potential V_3 in a third duration, T_3 , where the second duration T_2 is immediately after the first duration T_1 , and the third duration T_3 is immediately after the second duration T_2 . In one embodiment, as shown in FIG. 5, $V_1 = V_3 > V_2$, $T_1 = T_2$, and $T_3 = 2T_1$. V_1 (V_3) and V_2 are corresponding to a high voltage potential and a low voltage potential, respectively, for effectively turning on and off the corresponding transistors of a corresponding pixel row. The waveform **270** of each of the scanning signals **271**, **272** and **273** is sequentially shifted from one another so as to activate the three pixel rows in a predetermined sequence. In this exemplary embodiment, the scanning signal **272** is shifted by a duration of $T_1 + T_2$ from the scanning signal **271**, and the scanning signal **273** is shifted by the duration of $T_1 + T_2$ from the scanning signal **272**, respectively.

The common signal V_{com} **290** has a constant potential (voltage). The data signals **281** and **282** are generated according to an image to be displayed on these pixels and have inverted polarities. That is, if the data signal **281** has a positive voltage, then the data signal **282** has a negative voltage, and vice versus. In the embodiment, the data signal **281** has a positive voltage, while the data signal **282** has a negative voltage.

As shown in FIG. 4, in the time period 1 of $(t_1 - t_0)$, the transistors **212** and **216** electrically connected to the scanning lines G_1 and G_2 are turned on, while the transistors **212** and **216** electrically connected to the scanning line G_3 are turned off, respectively. Accordingly, a positive voltage is generated in the first sub-pixel electrode **215a** of the pixels $P_{1,0}$ by application of the data signal **281** to the source of the second transistor **216** of the pixels $P_{1,0}$, while a negative voltage is generated in the first electrode **215a** of the pixel $P_{1,1}$ by application of the data signal **282** to the source of the second transistor **216** of the pixels $P_{1,1}$. As shown in FIG. 5, the generated positive voltage in the first sub-pixel electrode **215a** of the pixels $P_{1,0}$ and the generated negative voltage in the first sub-pixel electrode **215a** of the pixels $P_{1,1}$ are indicated by symbols “+” and “-” therein, respectively. Additionally, the numerals “1”, “2”, “3”, “4” and “6” labeled in the sub-pixels $P_{1,0}(1)/P_{1,1}(1)$, $P_{0,1}(1)/P_{0,2}(1)$, $P_{2,1}(2)/P_{2,2}(2)$, $P_{1,0}(2)/P_{1,1}(2)$ and $P_{2,1}(1)/P_{2,2}(1)$ in the FIG. 5 respectively refers to the time periods 1, 2, 3, 4 and 6 when the corresponding sub-pixel is charged.

In the time period 2 of $(t_2 - t_1)$, the transistors **212** and **216** electrically connected to the scanning line G_1 are turned on, while the transistors **212** and **216** electrically connected to the scanning lines G_2 and G_3 are turned off, respectively. Accordingly, a positive voltage is generated in the first sub-pixel electrode **215a** of the pixel $P_{0,1}$ by application of the data signal **281** to the source of the first transistor **212** of the pixel $P_{0,1}$, while a negative voltage is generated in the first sub-pixel electrode **215a** of the pixel $P_{0,2}$ by application of the data signal **282** to the source of the first transistor **212** of the pixel $P_{0,2}$. As shown in FIG. 5, the generated positive voltage in the

first sub-pixel electrode **215a** of the pixels $P_{0,1}$ and the generated negative voltage in the first sub-pixel electrode **215a** of the pixels $P_{0,1}$ are indicated by symbols “+” and “-” therein, respectively.

As shown in FIG. 5, in the time period **3** of (t_3-t_2) , the transistors **212** and **216** electrically connected to the scanning lines G_2 and G_3 are turned on, while the transistors **212** and **216** electrically connected to the scanning line G_1 are turned off, respectively. Accordingly, a positive voltage is generated in the second sub-pixel electrode **215b** of the pixels $P_{2,1}$ by application of the data signal **281** to the source of the first transistor **212** of the pixel $P_{2,1}$, and a negative voltage is generated in the second sub-pixel electrode **215b** of the pixels $P_{2,2}$ by application of the data signal **282** to the source of the first transistor **212** of the pixel $P_{2,2}$, which are indicated by symbols “+” and “-” therein, respectively.

Accordingly, for this pixel arrangement and driving scheme, the dot inversion is achieved in the pixel matrix $\{P_{n,m}\}$ of the LCD panel **200** for the image display, with the data inputting into the data lines in the column inversion.

However, the simplified waveform (pulses) and their timing sequence (gate timing) in the scanning signals g_1 , g_2 and g_3 as shown in FIG. 4 may cause a mura effect in the LCD panel of the present invention in display, since charging/discharging some sub-pixels of the LCD panel may generate a first feed through, while charging/discharging other sub-pixels of the LCD panel may generate a first and second feed through. FIGS. 6 and 7 show the effects of the multi-gate pulse and the order of turning-off gates on an LCD panel **300** of the present invention in display, where g_1 , g_2 , g_3 , g_4 and g_5 are the scanning signals applied to the scanning lines G_1 , G_2 , G_3 , G_4 and G_5 , respectively, and A_data , B_data , C_data and D_data represent the voltage potential of the sub-pixels A, B, C and D, respectively. In this example, it is assumed that each of four sub-pixels A ($P_{2,1}(1)$), B ($P_{1,2}(1)$), C ($P_{3,2}(2)$) and D ($P_{2,1}(2)$) will be charged to 4V and each feed through is about 1V. The pixel arrangement in the LCD panel **300** partially shown in FIG. 6 is substantially identical to that in the LCD panel partially shown in FIG. 5.

In operation, in the time period of (t_1-t_0) , the gates G_2 and G_3 are turned on, i.e., the transistors **312** and **316** electrically connected to the scanning lines G_2 and G_3 are turned on, the sub-pixel A is charged to 4V by applying the data signal through the data line D_2 . At time t_1 , the gate G_3 is turned off, which generates a first feed through in the sub-pixel A, thereby reducing A_data to 3V thereafter. Meantime, the sub-pixel B is charged to 4V. Then, at time t_2 , the gate G_2 is turned off as well, which generates a second feed through in the sub-pixel A and a first feed through in the sub-pixel B, respectively, thereby reducing A_data to 2V and B_data to 3V, respectively, thereafter. In the time period of (t_3-t_2) , the gates G_3 and G_4 are turned on, the sub-pixel C is charged to 4V. At time t_3 , the gate G_4 is turned off, which generates a first feed through in the sub-pixel C, thereby reducing C_data to 3V thereafter. Meantime, the sub-pixel D is charged to 4V. Then, at time t_4 , the gate G_3 is turned off as well, which generates a second feed through in the sub-pixel C and a first feed through in the sub-pixel D, respectively, thereby reducing C_data to 2V and D_data to 3V, respectively, thereafter.

The non-uniformity of the potential voltages in the sub-pixels A and B, and C and D cause the mura effect, a defect in intensity in displayed images. In order to get rid of the mura effect, the gate timing needs being modified such that the gates are turned on and/or turned off in a predetermined order. This can be implemented by modulating the waveform of the scanning signals g_1 , g_2 , g_3 , g_4 and g_5 applied to the scanning lines G_1 , G_2 , G_3 , G_4 and G_5 , respectively.

FIG. 8 shows the scanning signals according to one embodiment of the present invention. Each of the scanning signals g_1 , g_2 , g_3 , g_4 and g_5 is configured to have a waveform **370**. The waveform **370** has a first voltage potential V_1 in a first duration, T_1 , a second voltage potential V_2 in a second duration, T_2 , a third voltage potential V_3 in a third duration, T_3 , a fourth voltage potential V_4 in a fourth duration, T_4 , and a fifth voltage potential V_5 in a fifth duration, T_5 , where the $(j+1)$ -th duration T_{j+1} is immediately after the j -th duration T_j , $j=1, 2, 3$ and 4. In the exemplary embodiment, as shown in FIG. 8, $V_1=V_3=V_5>V_2=V_4$, $T_2=(T_1+2t)$, $T_3=(T_1-t)$, $T_4=2t$, $T_5=T_1$, and $T_1>>t$. In this embodiment, V_1 (V_3 , V_5) and V_2 (V_4) are corresponding to a high voltage potential and a low voltage potential, respectively, for effectively turning on and off the corresponding transistors of a corresponding pixel row. The waveform **370** of each of the scanning signals g_1 , g_2 , g_3 , g_4 and g_5 is sequentially shifted from one another so as to activate the three pixel rows in a predetermined order (sequence). In this exemplary embodiment, the scanning signal g_2 is shifted by a duration of T_1+T_2 from the scanning signal g_1 , the scanning signal g_3 is shifted by the duration of T_1+T_2 from the scanning signal g_2 , the scanning signal g_4 is shifted by the duration of T_1+T_2 from the scanning signal g_3 , and the scanning signal g_5 is shifted by the duration of T_1+T_2 from the scanning signal g_4 , respectively.

When such scanning signals g_1 , g_2 , g_3 , g_4 and g_5 are applied to the scanning lines G_1 , G_2 , G_3 , G_4 and G_5 , respectively, each of the four sub-pixels A, B, C and D as shown in FIG. 6 will be charged to have a uniform voltage potential, thereby causing no mura effect to occur in the LCD panel **300** in operation. For example, in the time period of (t_1-t_0) , the gates G_2 and G_3 are turned on, the sub-pixel A is charged to 4V by applying the data signal through the data line D_2 . At time t_1 , the gate G_2 is turned off, which generates a feed through in the sub-pixel A, thereby reducing A_data to 3V thereafter. At time t_2 , the gate G_3 is turned off as well. However, the turning off of the gate G_3 generates no feed through in the sub-pixel A since the gate G_2 has already been turned off at this time t_2 . The voltage potential of the sub-pixel A, A_data at time t_2 is still about 3V, as shown in FIG. 8. At time t_3 , the gate G_2 is re-turned on, and the sub-pixel A is charged back to 4V again. Meanwhile, the sub-pixel B is charged to 4V. Then, at time t_4 , the gate G_2 is turned off, which generates a feed through in both the sub-pixels A and B. In this case, both A_data and B_data have an identical voltage potential, which is about 3V, as shown in FIG. 8.

Similarly, the voltage potentials of the sub-pixels C and D, C_data and D_data , are also about 3V, which are identical to that of the sub-pixels A and B.

FIG. 9 shows the scanning signals according to another embodiment of the present invention. Each of the scanning signals g_1 , g_2 , g_3 and g_4 can be obtained by modulating (or angle-trimming) a corresponding scanning signal shown in FIGS. 4 and 7, such that the waveform **470** of each scanning signal has a first voltage potential $V_1(t)$ in a first duration, T_1 , a second voltage potential $V_2(t)$ in a second duration, T_2 , and a third voltage potential $V_3(t)$ in a third duration, T_3 , where the second duration T_2 is immediately after the first duration T_1 , and the third duration T_3 is immediately after the second duration T_2 . $V_1(t)$ and $V_3(t)$ vary with time, while $V_2(t)=V_2$ is a constant and independent of time. As shown in FIG. 9, the first duration T_1 includes a first time period, T_0 , and a second time period, $T=(T_1-T_0)$, immediately after the first time period T_0 . In the first time period T_0 , $V_1(t)=V_1$, a constant voltage potential, while $V_1(t)$ continuously decreases from V_1 to V_0 as time goes in the second time period T . Additionally, the third duration T_3 includes a first time period, T_0 , a second

time period, T , immediately after the first time period T_0 , and a third time period ($T_3 - T_1 - T_0$), immediately after the second time period T . For the voltage potential $V_3(t)$ in the third duration T_3 , $V_3(t) = V_3$, a constant voltage potential, in the first time period T_0 , in the second time period T , $V_3(t)$ continuously decreases from V_3 to V_0 as time goes and $V_3(t) = V_3$ in the third time period. In one embodiment, as shown in FIG. 9, $V_1 = V_3 > V_2$, $V_1 > V_0 \geq V_2$, $T_1 = T_2$, and $T_3 = 2T_1$. V_1 (V_3) and V_2 are corresponding to a high voltage potential and a low voltage potential, respectively, for effectively turning on and off the corresponding transistors of a corresponding pixel row. The waveform 470 of each of the scanning signals g_1 , g_2 , g_3 and g_4 is sequentially shifted from one another so as to activate the three pixel rows in a predetermined sequence. In this exemplary embodiment, the scanning signal g_2 is shifted by a duration of $T_1 + T_2$ from the scanning signal g_1 , the scanning signal g_3 is shifted by the duration of $T_1 + T_2$ from the scanning signal g_2 , and the scanning signal g_4 is shifted by the duration of $T_1 + T_2$ from the scanning signal g_3 , respectively.

When the scanning signals g_1 , g_2 , g_3 and g_4 are applied to the scanning lines G_1 , G_2 , G_3 and G_4 , respectively, of the LCD panel 300, as shown in FIG. 6, the mura effect can be substantially reduced. For example, in the time period of ($t_1 - t_0$), the gates G_2 and G_3 are turned on, the sub-pixel A is fully charged. Starting at time t_1 , the gate G_3 is slowly being turned off till at time t_2 , where $t_2 = (t_1 + T)$. Meanwhile, the gate G_2 is slowly being turned off as well, which substantially reduces the first feed through effect in the sub-pixel A generated by turning off the gate G_3 . The longer the time period T is, the slower the gate G_2 is being turning off, the smaller the first feed through effect is in the sub-pixel A. Similarly, the first feed through effect in the sub-pixel C can also be substantially reduced. As a result, the mura effect in the LCD panel 300 is reduced.

FIG. 10 and Table 1 show a simulation result for the scanning signals having a waveform shown in FIGS. 4 and 7. The voltage potential difference between the sub-pixels A and D is $\Delta V = 550$ mV

FIG. 11 and Table 2 show a simulation result for the scanning signals having a waveform shown in FIG. 9. The voltage potential difference between the sub-pixels A and D is $\Delta V = 450$ mV, which is smaller than 550 mV, the voltage potential difference between the sub-pixels A and D for the scanning signals having a waveform shown in FIGS. 4 and 7.

FIG. 12 shows waveform charts of scanning signals g_0 , g_1 , g_2 and g_3 applied to an LCD panel 500 and charging in the corresponding sub-pixel electrodes 515a and 515b of the LCD panel 500 according to one embodiment of the present invention. In the exemplary embodiment as shown in FIG. 13, the pixel arrangement/layout of the LCD panel 500 is same as that shown in FIG. 5. For the purpose of illustration of the present invention, the LCD panel 500 is shown schematically and partially with 3×3 pixels, where the pixels, for example, in the first column of the 3×3 pixel matrix are referenced by $P_{1,1}$, $P_{2,1}$ and $P_{3,1}$, respectively. Each pixel has a first sub-pixel electrode 515a, a second sub-pixel electrode 515b, a first transistor (switching device) 512 and a second transistor (switching device) 516, each transistor 512/516 having a gate, a source and a drain. The gates of both the first transistor 512 and the second transistor 516 of each pixel are electrically connected to a pair of two neighboring scanning lines, respectively, by which the pixel is defined, such as G_0 and G_1 , G_1 and G_2 or G_2 and G_3 . The drains of the first transistor 512 and the second transistor 516 of each pixel are electrically connected to the first sub-pixel electrode 515a and the second sub-pixel electrode 515b of the pixel, respectively.

TABLE 1

A simulation result for un-gate shaping							
Shaping Voltage	V0	Vf1	V1	Vf2	$\Delta V1$	$\Delta V2$	ΔV_{total}
A	5.9	5.385	5.385	4.258	0.515	1.127	1.542
D	5.9	5.9	5.9	4.809	0	1.091	1.091

TABLE 2

A simulation result for gate shaping							
Shaping Voltage	V0	Vf1	V1	Vf2	$\Delta V1$	$\Delta V2$	ΔV_{total}
A	5.9	5.479	5.479	4.357	0.421	1.122	1.543
D	5.9	5.9	5.9	4.809	0	1.091	1.091

For the pixels $P_{1,1}$, $P_{1,2}$ and $P_{1,3}$ of the first pixel row defined by the pair of two neighboring scanning lines G_0 and G_1 , the source of the first transistor 512 of each pixel $P_{1,1}$, $P_{1,2}$ or $P_{1,3}$ is electrically connected to a corresponding data line D_0 , D_1 or D_2 , while the source of the second transistor 516 of each pixel $P_{1,1}$, $P_{1,2}$ or $P_{1,3}$ is electrically connected to the first sub-electrode 515a of the pixel. However, for the pixels $P_{2,1}$, $P_{2,2}$ and $P_{2,3}$ of the second pixel row defined by the pair of two neighboring scanning lines G_1 and G_2 , the source of the first transistor 512 of each pixel $P_{2,1}$, $P_{2,2}$ or $P_{2,3}$ is electrically connected to the second sub-electrode 515b of the pixel, while the source of the second transistor 516 of each pixel $P_{1,1}$, $P_{1,2}$ or $P_{1,3}$ is electrically connected to a corresponding data line D_1 , D_2 or D_3 . The pixel arrangement repeats in every two neighboring pixel rows, as shown in FIG. 13.

In the exemplary embodiment, the driving signals include four scanning signals g_0 , g_1 , g_2 , and g_3 respectively applied to the scanning lines G_0 , G_1 , G_2 and G_3 . Each of the scanning signals g_0 , g_1 , g_2 , and g_3 has a waveform 570. The waveform 570 has a first voltage potential V_1 in a first duration, T_1 , a second voltage potential V_2 in a second duration, T_2 , a third voltage potential V_3 in a third duration, T_3 , a fourth voltage potential V_4 in a fourth duration, T_4 , and a fifth voltage potential V_5 in a fifth duration, T_5 , where the (+1)-th duration T_{j+1} is immediately after the j -th duration T_j , $j=1, 2, 3$, and 4. In one embodiment, as shown in FIG. 13, $V_1 = V_3 = V_5 > V_2 = V_4$, $T_1 = T_3 = T_5$, and $T_2 = 2T_1$, and $T_4 < T_1$. In one embodiment, V_1 (V_3 , V_5) and V_2 (V_4) are corresponding to a high voltage potential and a low voltage potential, respectively, for effectively turning on and off the corresponding transistors of a corresponding pixel row. The waveform 570 of each of the scanning signals g_0 , g_1 , g_2 , and g_3 is sequentially shifted from one another so as to activate the three pixel rows in a predetermined sequence. In this exemplary embodiment, the scanning signal g_1 is shifted by a duration of $T_1 + T_2$ from the scanning signal g_0 , the scanning signal g_2 is shifted by the duration of $T_1 + T_2$ from the scanning signal g_1 , and the scanning signal g_3 is shifted by the duration of $T_1 + T_2$ from the scanning signal g_2 , respectively.

The data signals d_1 , d_2 , d_3 and d_4 (not shown in FIG. 12) generated according to an image to be displayed on these pixels are configured to have inverted polarities and respectively applied to the data lines D_0 , D_1 , D_2 and D_3 .

Accordingly, for such a pixel arrangement and driving scheme, the dot inversion is achieved in the pixel matrix $\{P_{n,m}\}$ of the LCD panel 500 for the image display, with the data inputting into the data lines in the column inversion.

FIG. 13 shows an example how the data signal d_1 having a positive voltage is delivered to corresponding sub-pixels of the LCD panel 500.

In the time period of (t_1-t_0) , only the transistors 512 and 516 electrically connected to the scanning lines G_0 and G_1 are turned on, the data signal d_1 is transmitted through the sub-pixels A, B and X. Eventually, the data signal d_1 is delivered to the sub-pixel B (the second sub-pixel 515b of the pixel $P_{1,2}$), which is indicated by symbol “+”.

In the time period of (t_2-t_1) , none of the transistors 512 and 516 of the LCD panel 500 is turned on, thus, the data signal d_1 is delivered to nowhere.

In the time period of (t_3-t_2) , only the transistors 512 and 516 electrically connected to the scanning line G_0 , then the data signal d_1 is delivered to the sub-pixel X.

In the time period of (t_4-t_3) , none of the transistors 512 and 516 of the LCD panel 500 is turned on, and the data signal d_1 is delivered to nowhere.

In the time period of (t_5-t_4) , only the transistors 512 and 516 electrically connected to the scanning lines G_1 and G_2 , the data signal d_1 is transmitted through the sub-pixels A, C and D. Eventually, the data signal d_1 is delivered to the sub-pixel C (the first sub-pixel $P_{2,1}$ (1) 515a of the pixel $P_{2,1}$).

In the time period of (t_6-t_5) , none of the transistors 512 and 516 of the LCD panel 500 is turned on, thus, the data signal d_1 is delivered to nowhere.

In the time period of (t_7-t_6) , only the transistors 512 and 516 electrically connected to the scanning line G_1 , thus the data signal d_1 is delivered to the sub-pixel A (the first sub-pixel $P_{1,2}$ (1) 515a of the pixel $P_{1,2}$).

In the time period of (t_8-t_7) , none of the transistors 512 and 516 of the LCD panel 500 is turned on, thus, the data signal d_1 is delivered to nowhere.

In the time period of (t_9-t_8) , only the transistors 512 and 516 electrically connected to the scanning lines G_2 and G_3 , the data signal d_1 is transmitted through the sub-pixels D, E and F. Eventually, the data signal d_1 is delivered to the sub-pixel F (the second sub-pixel $P_{3,2}$ (2) 515b of the pixel $P_{3,2}$).

In the time period of $(t_{10}-t_9)$, none of the transistors 512 and 516 of the LCD panel 500 is turned on, and the data signal d_1 is delivered to nowhere.

In the time period of $(t_{11}-t_{10})$, only the transistors 512 and 516 electrically connected to the scanning line G_2 , thus the data signal d_1 is delivered to the sub-pixel D (the second sub-pixel $P_{2,1}$ (2) 515b of the pixel $P_{2,1}$).

Repeating the process for the other data signals results in the dot inversion of display in the LCD panel 500, as shown in FIG. 13, where symbol “+” or “-” is used to indicate that a corresponding sub-pixel is charged with a positive voltage potential or a negative voltage potential, respectively.

According to the embodiments of the present invention as disclosed above, each data line is electrically coupled its two neighboring pixel columns, and the data signals applied to the corresponding data lines have voltages of alternating polarity, i.e., the column inversion, thus, only half number of data lines may be needed in order to achieve the dot inversion in the LCD panel, comparing to that of a conventional LCD panel of the dot inversion, which may significantly reduce the power consumption.

Referring to FIG. 14, an LCD panel 600 is shown according to another embodiment of the present invention. The LCD panel 600 includes a plurality of touch sensing signal lines $\{L_k\}$, integrated with the pixel arrangement of the LCD panel shown in FIG. 1, where $k=1, 2, \dots, K$, K being an integer greater than zero. The touch sensing signal line L_k is arranged adjacent and parallel to the data line D_{m+1} . Other arrangements of the plurality of touch sensing signal lines $\{L_k\}$ can

also be utilized to practice the present invention. For example, the touch sensing signal line L_k can be arranged adjacent and parallel to the scanning line D_m or D_{m+1} .

In one embodiment, each pixel in the even number pixel rows of the pixel matrix or each pixel in the odd number pixel rows of the pixel matrix further comprises a photo sensor (PS) and a transistor having a gate electrically connected to one of two corresponding scanning lines defining the pixel, a source electrically connected the photo sensor and a drain electrically connected to a corresponding touch sensing signal line. For example, as shown in FIG. 14, the pixel $P_{n,m}$ in the pixel row $P_{n,\{m\}}$ defined by the two scanning lines D_n and D_{n+1} further includes a PS 650 and a transistor 618 having a gate 618g electrically connected to the scanning line D_{m+1} , a source 618s electrically connected the PS 650 and a drain 618d electrically connected to the corresponding touch sensing signal line L_k .

Similarly, when the above discussed driving signals are applied to the LCD panel 600, a dot inversion image display is achieved. Because each data line D_m is electrically coupled to both the pixel column $P_{\{n\},m}$ and its neighboring pixel column $P_{\{n\},m+1}$, only half number of data lines $\{D_m\}$ may be needed in order to achieve the dot inversion in the LCD panel 600, comparing to that of a conventional LCD panel of the dot inversion. Accordingly, the LCD panel 600 may save as much as half of power consumption of the conventional LCD panel of the dot inversion.

FIGS. 15 and 16 show schematically layout views of the LCD panel according to two embodiments of the present invention, respectively.

One aspect of the present invention provides an LCD panel having a plurality of pixels, $\{P_{n,m}\}$, spatially arranged in the form of a matrix, $n=1, 2, \dots, N$, and $m=1, 2, \dots, M$, and N, M being an integer greater than zero. Each pixel $P_{n,m}$ has at least a first sub-pixel, $P_{n,m}$ (1) and a second sub-pixel, $P_{n,m}$ (2), where each of the first sub-pixel $P_{n,m}$ (1) and the second sub-pixel $P_{n,m}$ (2) comprises a sub-pixel electrode and a switching element electrically coupled to the sub-pixel electrode. The switching element is a field-effect thin film transistor (TFT), or the like.

The LCD panel also has a plurality of scanning lines, $\{G_n\}$, spatially arranged along a row direction. Each pair of two neighboring scanning lines G_n and G_{n+1} , defines a pixel row $P_{n,\{m\}}$ of the pixel matrix $\{P_{n,m}\}$ therebetween and is electrically coupled to the switching elements of the first sub-pixel and the second sub-pixel of each pixel in the pixel row $P_{n,\{m\}}$, respectively.

The LCD panel further has a plurality of data lines, $\{D_m\}$, spatially arranged crossing the plurality of scanning lines $\{G_n\}$ along a column direction perpendicular to the row direction. Each pair of two neighboring data lines D_m and D_{m+1} defines a pixel column, $P_{\{n\},m}$, of the pixel matrix $\{P_{n,m}\}$ therebetween. Each data line D_m is electrically coupled to the switching element of the first sub-pixel or the second sub-pixel of each odd pixel of one of two neighboring pixel columns $P_{\{n\},m-1}$ and $P_{\{n\},m}$ associated with the data line D_m and to the switching element of the second sub-pixel or the first sub-pixel of each even pixel of the other of the two neighboring pixel columns $P_{\{n\},m-1}$ and $P_{\{n\},m}$.

Additionally, the LCD panel may have a plurality of touch sensing signal lines $\{L_k\}$, $k=1, 2, \dots, K$, K being an integer greater than zero. Each touch sensing signal line is arranged adjacent and parallel to a scanning line G_n or a data line D_m . In one embodiment, each pixel in the even number pixel rows of the pixel matrix or each pixel in the odd number pixel rows of the pixel matrix further comprises a photo sensor (PS) and a transistor having a gate electrically connected to one of two

corresponding scanning lines defining the pixel, a source electrically connected the photo sensor and a drain electrically connected to a corresponding touch sensing signal line.

Furthermore, the LCD panel has a gate driver for generating a plurality of scanning signals respectively applied to the plurality of scanning lines $\{G_n\}$, where the plurality of scanning signals is configured to turn on the switching elements connected to the plurality of scanning lines $\{G_n\}$ in a predefined sequence; and a data driver for generating a plurality of data signals respectively applied to the plurality of data lines $\{D_m\}$, where the plurality of data signals is configured such that any two neighboring data signals have inverted polarities. The plurality of pixels $\{P_{n,m}\}$ has a pixel polarity that is in the dot inversion.

Another aspect of the present invention provides a method of driving a liquid crystal display (LCD) panel as disclosed above. The method includes the step of applying a plurality of scanning signals to the plurality of scanning lines $\{G_n\}$ and a plurality of data signals to the plurality of data lines $\{D_m\}$, respectively. The plurality of scanning signals is configured to turn on the transistors connected to the plurality of scanning lines $\{G_n\}$ in a predefined sequence, and the plurality of data signals is configured such that any two neighboring data signals have inverted polarities. As a result, the plurality of pixels $\{P_{n,m}\}$ has a pixel polarity that is in the dot inversion.

In sum, the present invention, among other things, discloses a liquid crystal display (LCD) panel with power consumption reduction and methods of driving same. The LCD panel in one embodiment includes a pixel matrix, a plurality of scanning lines and a plurality of data lines. Each pair of two neighboring scanning lines defines a pixel row therebetween, and each pair of two neighboring data lines defines a pixel column therebetween. Each pixel has at least a first sub-pixel and a second sub-pixel. Each sub-pixel has a sub-pixel electrode and a switching element electrically coupled to the sub-pixel electrode. Each pair of two neighboring scanning lines is electrically coupled to the switching elements of the first sub-pixel and the second sub-pixel of each pixel in the pixel row, respectively. Each data line is electrically coupled to the switching element of the first sub-pixel or the second sub-pixel of each odd pixel of one of two neighboring pixel columns associated with the data line and to the switching element of the second sub-pixel or the first sub-pixel of each even pixel of the other of the two neighboring pixel columns. The LCD panel further includes a gate driver and a data driver for generating scanning signals and data signals applied to the plurality of scanning lines and the plurality of data lines, respectively. The scanning signals are configured to turn on the switching elements connected to the plurality of scanning lines in a predefined sequence, and the data signals are configured such that any two neighboring data signals have inverted polarities.

The foregoing description of the exemplary embodiments of the invention has been presented only for the purposes of illustration and description and is not intended to be exhaustive or to limit the invention to the precise forms disclosed. Many modifications and variations are possible in light of the above teaching.

The embodiments were chosen and described in order to explain the principles of the invention and their practical application so as to activate others skilled in the art to utilize the invention and various embodiments and with various modifications as are suited to the particular use contemplated. Alternative embodiments will become apparent to those skilled in the art to which the present invention pertains without departing from its spirit and scope. Accordingly, the scope of the present invention is defined by the appended claims

rather than the foregoing description and the exemplary embodiments described therein.

What is claimed is:

1. A method of driving a liquid crystal display (LCD), comprising the steps of:

(a) providing an LCD panel comprising:

(i) a common electrode;

(ii) a plurality of scanning lines, $\{G_n\}$, $n=1, 2, \dots, N$, N being an integer greater than zero, spatially arranged along a row direction;

(iii) a plurality of data lines, $\{D_m\}$, $m=1, 2, \dots, M$, M being an integer greater than zero, spatially arranged crossing the plurality of scanning lines $\{G_n\}$ along a column direction perpendicular to the row direction; and

(iv) a plurality of pixels, $\{P_{n,m}\}$, spatially arranged in the form of a matrix, each pixel $P_{n,m}$ defined between two neighboring scanning lines G_n and G_{n+1} and two neighboring data lines D_m and D_{m+1} , and comprising at least a first sub-pixel, $P_{n,m}(1)$, and a second sub-pixel, $P_{n,m}(2)$, wherein each of the first sub-pixel and the second sub-pixel comprises a sub-pixel electrode, a liquid crystal (LC) capacitor electrically coupled between the sub-pixel electrode and the common electrode in parallel, and a transistor having a gate, a source and a drain electrically coupled to the sub-pixel electrode, wherein the gate and the source of the transistor of the first sub-pixel $P_{n,m}(1)$ of the pixel $P_{n,m}$ are electrically coupled to the scanning line G_{n+1} and the data line D_m , respectively, and wherein the gate and the source of the transistor of the second sub-pixel $P_{n,m}(2)$ of the pixel $P_{n,m}$ are electrically coupled to the scanning line G_n and the sub-pixel electrode of the first sub-pixel $P_{n+1,m}(1)$, respectively; and

wherein the gate and the source of the transistor of the first sub-pixel $P_{n-1,m}(1)$ of the pixel $P_{n-1,m}$ are electrically coupled to the scanning line G_{n+1} and the sub-pixel electrode of the second sub-pixel $P_{n+1,m}(2)$, respectively, and wherein the gate and the source of the transistor of the second sub-pixel $P_{n+1,m}(2)$ of the pixel $P_{n+1,m}$ are electrically coupled to the scanning line G_{n-2} and the data line D_{m-1} , respectively; and

(b) applying a plurality of scanning signals to the plurality of scanning lines $\{G_n\}$ and a plurality of data signals to the plurality of data lines $\{D_m\}$, respectively, wherein the plurality of scanning signals is configured to turn on the transistors connected to the plurality of scanning lines $\{G_n\}$ in a predefined sequence, and the plurality of data signals is configured such that any two neighboring data signals have inverted polarities.

2. The method of claim 1, wherein each of the plurality of scanning signals is configured to have a waveform, wherein the waveform has a first voltage potential V_1 in a first duration, T_1 , a second voltage potential V_2 in a second duration, T_2 , a third voltage potential V_3 in a third duration, T_3 , a fourth voltage potential V_4 in a fourth duration, T_4 , and a fifth voltage potential V_5 in a fifth duration, T_5 , wherein the $(j+1)$ -th duration T_{j+1} is immediately after the j -th duration T_j , $j=1, 2, 3$ and 4 , and wherein $V_1=V_3=V_5>V_2=V_4$, $T_2=(T_1+2t)$, $T_3=(T_1-t)$, $T_4=2t$, $T_5=T_1$, and $T_1>>t$.

3. The method of claim 2, wherein the waveform of each of the scanning signals is sequentially shifted from one another by a duration of T_1+T_2 .

4. The method of claim 1, wherein each of the plurality of scanning signals is configured to have a waveform, wherein the waveform of each of the plurality of scanning signals has

a first voltage potential $V_1(t)$ in a first duration, T_1 , a second voltage potential $V_2(t)$ in a second duration, T_2 , and a third voltage potential $V_3(t)$ in a third duration, T_3 , wherein the second duration T_2 is immediately after the first duration T_1 and the third duration T_3 is immediately after the second duration T_2 , and wherein $V_1(t)$ and $V_3(t)$ vary with time and $V_2(t)=V_2$ is a constant and independent of time.

5 **5.** The method of claim 4, wherein the first duration T_1 includes a first time period, T_0 , and a second time period, $T=(T_1-T_0)$, immediately after the first time period T_0 , wherein in the first time period T_0 , $V_1(t)=V_1$, a constant voltage potential, and $V_1(t)$ continuously decreases from V_1 to V_0 as time goes in the second time period T , and wherein the third duration T_3 includes a first time period, T_0 , a second time period, T , immediately after the first time period T_0 , and a third time period $(T_3-T_1-T_0)$, immediately after the second time period T , wherein $V_3(t)=V_3$, a constant voltage potential, in the first time period T_0 , $V_3(t)$ continuously decreases from V_3 to V_0 as time goes in the second time period T , and $V_3(t)=V_3$ in the third time period, and wherein $V_1=V_3>V_2$, $V_1>V_0\geq V_2$, $T_1=T_2$, and $T_3=2T_1$.

6. The method of claim 5, wherein the waveform of each of the scanning signals is sequentially shifted from one another by a duration of T_1+T_2 .

7. The method of claim 1, wherein, in operation, the plurality of pixels $\{P_{n,m}\}$ has a pixel polarity that is in a dot inversion.

8. The method of claim 1, wherein each of the first sub-pixel $P_{n,m}(1)$ and the second sub-pixel $P_{n,m}(2)$ of the pixel $P_{n,m}$ further comprises a storage capacitor electrically coupled between the sub-pixel electrode and the common electrode in parallel.

9. The method of claim 1, wherein the LCD panel further comprises a plurality of touch sensing signal lines $\{L_k\}$, $k=1, 2, \dots, K$, K being an integer greater than zero, each being arranged adjacent and parallel to a scanning line G_n or a data line D_m .

10. The method of claim 9, wherein each pixel in the even number pixel rows of the pixel matrix or each pixel in the odd number pixel rows of the pixel matrix further comprises a photo sensor (PS) and a transistor having a gate electrically connected to one of two corresponding scanning lines defining the pixel, a source electrically connected to the photo sensor and a drain electrically connected to a corresponding touch sensing signal line.

11. A method of driving a liquid crystal display (LCD), comprising the steps of:

(a) providing an LCD panel comprising:

(i) a plurality of pixels, $\{P_{n,m}\}$, spatially arranged in the form of a matrix, $n=1, 2, \dots, N$, and $m=1, 2, \dots, M$, and N, M being an integer greater than zero, each pixel $P_{n,m}$ comprising at least a first sub-pixel, $P_{n,m}(1)$ and a second sub-pixel, $P_{n,m}(2)$, wherein each of the first sub-pixel $P_{n,m}(1)$ and the second sub-pixel $P_{n,m}(2)$ comprises a sub-pixel electrode and a switching element electrically coupled to the sub-pixel electrode;

(ii) a plurality of scanning lines, $\{G_n\}$, spatially arranged along a row direction, wherein each pair of two neighboring scanning lines G_n and G_{n+1} defines a pixel row $P_{n,\{m\}}$ of the pixel matrix $\{P_{n,m}\}$ therebetween and is electrically coupled to the switching elements of the first sub-pixel and the second sub-pixel of each pixel in the pixel row $P_{n,\{m\}}$, respectively; and

(iii) a plurality of data lines, $\{D_m\}$, spatially arranged crossing the plurality of scanning lines $\{G_n\}$ along a column direction perpendicular to the row direction,

wherein each pair of two neighboring data lines D_m and D_{m-1} defines a pixel column, $P_{\{n\},m}$, of the pixel matrix $\{P_{n,m}\}$ therebetween, and wherein each data line D_m is electrically coupled to the switching element of the first sub-pixel or the second sub-pixel of each odd pixel of one of two neighboring pixel columns $P_{\{n\},m-1}$ and $P_{\{n\},m}$ associated with the data line D_m and to the switching element of the second sub-pixel or the first sub-pixel of each even pixel of the other of the two neighboring pixel columns $P_{\{n\},m-1}$ and $P_{\{n\},m}$; and

(b) applying a plurality of scanning signals to the plurality of scanning lines $\{G_n\}$ and a plurality of data signals to the plurality of data lines $\{D_m\}$, respectively, wherein the plurality of scanning signals is configured to turn on the switching elements connected to the plurality of scanning lines $\{G_n\}$ in a predefined sequence, and the plurality of data signals is configured such that any two neighboring data signals have inverted polarities.

12. The method of claim 11, wherein, in operation, the plurality of pixels $\{P_{n,m}\}$ has a pixel polarity that is in the dot inversion.

13. The method of claim 11, wherein the LCD panel further comprises at least one common electrode.

14. The method of claim 13, wherein each of the first sub-pixel $P_{n,m}(1)$ and the second sub-pixel $P_{n,m}(2)$ of the pixel $P_{n,m}$ of the pixel matrix $\{P_{n,m}\}$ further comprises an LC capacitor electrically coupled between the sub-pixel electrode and the common electrode in parallel.

15. The method of claim 14, wherein each of the first sub-pixel $P_{n,m}(1)$ and the second sub-pixel $P_{n,m}(2)$ of the pixel $P_{n,m}$ of the pixel matrix $\{P_{n,m}\}$ further comprises a storage capacitor electrically coupled between the sub-pixel electrode and the common electrode in parallel.

16. The method of claim 11, wherein each of the switching elements of the first sub-pixel $P_{n,m}(1)$ and the second sub-pixel $P_{n,m}(2)$ of the pixel $P_{n,m}$ of the pixel matrix $\{P_{n,m}\}$ is a field-effect thin film transistor having a gate, a source and a drain.

17. The method of claim 15, wherein the drain of the transistor of each of the first sub-pixel $P_{n,m}(1)$ and the second sub-pixel $P_{n,m}(2)$ of each pixel $P_{n,m}$ of the pixel matrix $\{P_{n,m}\}$ is electrically coupled to the sub-pixel electrode of the corresponding sub-pixel;

wherein the gate and the source of the transistor of the first sub-pixel $P_{n,m}(1)$ of the pixel $P_{n,m}$ of the pixel matrix $\{P_{n,m}\}$ are electrically coupled to the scanning line G_{n+1} and the data line D_m , respectively;

wherein the gate and the source of the transistor of the second sub-pixel $P_{n,m}(2)$ of the pixel $P_{n,m}$ of the pixel matrix $\{P_{n,m}\}$ are electrically coupled to the scanning line G_n and the sub-pixel electrode of the first sub-pixel $P_{n,m}(1)$, respectively;

wherein the gate and the source of the transistor of the first sub-pixel $P_{n+1,m}(1)$ of the pixel $P_{n+1,m}$ of the pixel matrix $\{P_{n,m}\}$ are electrically coupled to the scanning line G_{n+1} and the sub-pixel electrode of the second sub-pixel $P_{n-1,m}(2)$, respectively; and

wherein the gate and the source of the transistor of the second sub-pixel $P_{n+1,m}(2)$ of the pixel $P_{n+1,m}$ of the pixel matrix $\{P_{n,m}\}$ are electrically coupled to the scanning line G_{n+2} and the data line D_{m+1} , respectively.

18. The method of claim 11, wherein the LCD panel further comprises a plurality of touch sensing signal lines $\{L_k\}$, $k=1, 2, \dots, K$, K being an integer greater than zero, each being arranged adjacent and parallel to a scanning line G_n or a data line D_m .

19. The method of claim 18, wherein each pixel in the even number pixel rows of the pixel matrix or each pixel in the odd number pixel rows of the pixel matrix further comprises a photo sensor (PS) and a transistor having a gate electrically connected to one of two corresponding scanning lines defining the pixel, a source electrically connected the photo sensor and a drain electrically connected to a corresponding touch sensing signal line.

20. A liquid crystal display (LCD) panel, comprising:

(a) a common electrode;

(b) a plurality of scanning lines, $\{G_n\}$, $n=1, 2, \dots, N$, N being an integer greater than zero, spatially arranged along a row direction;

(c) a plurality of data lines, $\{D_m\}$, $m=1, 2, \dots, M$, M being an integer greater than zero, spatially arranged crossing the plurality of scanning lines $\{G_n\}$ along a column direction perpendicular to the row direction; and

(d) a plurality of pixels, $\{P_{n,m}\}$, spatially arranged in the form of a matrix, each pixel $P_{n,m}$ defined between two neighboring scanning lines G_n and G_{n+1} and two neighboring data lines D_m and D_{m+1} , and comprising at least a first sub-pixel, $P_{n,m}(1)$, and a second sub-pixel, $P_{n,m}(2)$, wherein each of the first sub-pixel and the second sub-pixel comprises a sub-pixel electrode, a liquid crystal (LC) capacitor electrically coupled between the sub-pixel electrode and the common electrode in parallel, and a transistor having a gate, a source and a drain electrically coupled to the sub-pixel electrode,

wherein the gate and the source of the transistor of the first sub-pixel $P_{n,m}(1)$ of the pixel $P_{n,m}$ are electrically coupled to the scanning line G_{n+1} , and the data line D_m , respectively, and wherein the gate and the source of the transistor of the second sub-pixel $P_{n,m}(2)$ of the pixel $P_{n,m}$ are electrically coupled to the scanning line G_n and the sub-pixel electrode of the first sub-pixel $P_{n,m}(1)$, respectively; and

wherein the gate and the source of the transistor of the first sub-pixel $P_{n+1,m}(1)$ of the pixel $P_{n+1,m}$ are electrically coupled to the scanning line G_{n+1} and the sub-pixel electrode of the second sub-pixel $P_{n+1,m}(2)$, respectively, and wherein the gate and the source of the transistor of the second sub-pixel $P_{n+1,m}(2)$ of the pixel $P_{n+1,m}$ are electrically coupled to the scanning line G_{n+2} and the data line D_{m+1} , respectively.

21. The LCD panel of claim 20, wherein each of the first sub-pixel $P_{n,m}(1)$ and the second sub-pixel $P_{n,m}(2)$ of the pixel $P_{n,m}$ further comprises a storage capacitor electrically coupled between the sub-pixel electrode and the common electrode in parallel.

22. The LCD panel of claim 20, further comprising:

(a) a gate driver for generating a plurality of scanning signals respectively applied to the plurality of scanning lines $\{G_n\}$, wherein the plurality of scanning signals is configured to turn on the transistors connected to the plurality of scanning lines $\{G_n\}$ in a predefined sequence; and

(b) a data driver for generating a plurality of data signals respectively applied to the plurality of data lines $\{D_m\}$, wherein the plurality of data signals is configured such that any two neighboring data signals have inverted polarities.

23. The LCD panel of claim 22, wherein each of the plurality of scanning signals is configured to have a waveform, wherein the waveform has a first voltage potential V_1 in a first duration, T_1 , a second voltage potential V_2 in a second duration, T_2 , a third voltage potential V_3 in a third duration, T_3 , a fourth voltage potential V_4 in a fourth duration, T_4 , and a fifth

voltage potential V_5 in a fifth duration, T_5 , wherein the $(j+1)$ -th duration T_{j+1} is immediately after the j -th duration T_j , $j=1, 2, 3$ and 4 , and wherein $V_1=V_3=V_5>V_2=V_4$, $T_2=(T_1+2t)$, $T_3=(T_1-t)$, $T_4=2t$, $T_5=T_1$, and $T_1>>t$.

24. The LCD panel of claim 23, wherein the waveform of each of the scanning signals is sequentially shifted from one another by a duration of T_1+T_2 .

25. The LCD panel of claim 22, wherein each of the plurality of scanning signals is configured to have a waveform, wherein the waveform of each of the plurality of scanning signals has a first voltage potential $V_1(t)$ in a first duration, T_1 , a second voltage potential $V_2(t)$ in a second duration, T_2 , and a third voltage potential $V_3(t)$ in a third duration, T_3 , wherein the second duration T_2 is immediately after the first duration T_1 and the third duration T_3 is immediately after the second duration T_2 , and wherein $V_1(t)$ and $V_3(t)$ vary with time and $V_2(t)=V_2$ is a constant and independent of time.

26. The LCD panel of claim 25, wherein the first duration T_1 includes a first time period, T_0 , and a second time period, $T=(T_1-T_0)$, immediately after the first time period T_0 , wherein in the first time period T_0 , $V_1(t)=V_1$, a constant voltage potential, and $V_1(t)$ continuously decreases from V_1 to V_0 as time goes in the second time period T , and wherein the third duration T_3 includes a first time period, T_0 , a second time period, T , immediately after the first time period T_0 , and a third time period $(T_3-T_1-T_0)$, immediately after the second time period T , wherein $V_3(t)=V_3$, a constant voltage potential, in the first time period T_0 , $V_3(t)$ continuously decreases from V_3 to V_0 as time goes in the second time period T , and $V_3(t)=V_3$ in the third time period, and wherein $V_1=V_3>V_2$, $V_1>V_0\geq V_2$, $T_1=T_2$, and $T_3=2T_1$.

27. The LCD panel of claim 26, wherein the waveform of each of the scanning signals is sequentially shifted from one another by a duration of T_1+T_2 .

28. The LCD panel of claim 22, wherein, in operation, the plurality of pixels $\{P_{n,m}\}$ has a pixel polarity that is in a dot inversion.

29. The LCD panel of claim 20, wherein each of the transistors is a field-effect thin film transistor (TFT).

30. The LCD panel of claim 20, further comprising a plurality of touch sensing signal lines $\{L_k\}$, $k=1, 2, \dots, K$, K being an integer greater than zero, each being arranged adjacent and parallel to a scanning line G_n or a data line D_m .

31. The LCD panel of claim 30, wherein each pixel in the even number pixel rows of the pixel matrix or each pixel in the odd number pixel rows of the pixel matrix further comprises a photo sensor (PS) and a transistor having a gate electrically connected to one of two corresponding scanning lines defining the pixel, a source electrically connected the photo sensor and a drain electrically connected to a corresponding touch sensing signal line.

32. A liquid crystal display (LCD) panel, comprising:

(a) a plurality of pixels, $\{P_{n,m}\}$, spatially arranged in the form of a matrix, $n=1, 2, \dots, N$, and $m=1, 2, \dots, M$, and N, M being an integer greater than zero, each pixel $P_{n,m}$ comprising at least a first sub-pixel, $P_{n,m}(1)$ and a second sub-pixel, $P_{n,m}(2)$, wherein each of the first sub-pixel $P_{n,m}(1)$ and the second sub-pixel $P_{n,m}(2)$ comprises a sub-pixel electrode and a switching element electrically coupled to the sub-pixel electrode;

(b) a plurality of scanning lines, $\{G_n\}$, spatially arranged along a row direction, wherein each pair of two neighboring scanning lines G_n and G_{n+1} defines a pixel row $P_{n,\{m\}}$ of the pixel matrix $\{P_{n,m}\}$ therebetween and is electrically coupled to the switching elements of the first sub-pixel and the second sub-pixel of each pixel in the pixel row $P_{n,\{n\}}$, respectively; and

(c) a plurality of data lines, $\{D_m\}$, spatially arranged crossing the plurality of scanning lines $\{G_n\}$ along a column direction perpendicular to the row direction, wherein each pair of two neighboring data lines D_m and D_{m+1} defines a pixel column, $P_{\{n\},m}$, of the pixel matrix $\{P_{n,m}\}$ 5 therebetween, and wherein each data line D_m is electrically coupled to the switching element of the first sub-pixel or the second sub-pixel of each odd pixel of one of two neighboring pixel columns $P_{\{n\},m-1}$ and $P_{\{n\},m}$ associated with the data line D_m and to the switching element 10 of the second sub-pixel or the first sub-pixel of each even pixel of the other of the two neighboring pixel columns $P_{\{n\},m-1}$ and $P_{\{n\},m}$.

33. The LCD panel of claim 32, further comprising at least one common electrode. 15

34. The LCD panel of claim 33, wherein each of the first sub-pixel $P_{n,m}(1)$ and the second sub-pixel $P_{n,m}(2)$ of the pixel $P_{n,m}$ of the pixel matrix $\{P_{n,m}\}$ further comprises an LC capacitor electrically coupled between the sub-pixel electrode and the common electrode in parallel. 20

35. The LCD panel of claim 34, wherein each of the first sub-pixel $P_{n,m}(1)$ and the second sub-pixel $P_{n,m}(2)$ of the pixel $P_{n,m}$ of the pixel matrix $\{P_{n,m}\}$ further comprises a storage capacitor electrically coupled between the sub-pixel electrode and the common electrode in parallel. 25

36. The LCD panel of claim 32, wherein each of the switching elements of the first sub-pixel $P_{n,m}(1)$ and the second sub-pixel $P_{n,m}(1)$ of the pixel $P_{n,m}$ of the pixel matrix $\{P_{n,m}\}$ is a field-effect thin film transistor having a gate, a source and a drain. 30

37. The LCD panel of claim 36, wherein the drain of the transistor of each of the first sub-pixel $P_{n,m}(1)$ and the second sub-pixel $P_{n,m}(2)$ of the pixel $P_{n,m}$ of the pixel matrix $\{P_{n,m}\}$ is electrically coupled to the sub-pixel electrode of the corresponding sub-pixel; 35

wherein the gate and the source of the transistor of the first sub-pixel $P_{n,m}(1)$ of the pixel $P_{n,m}$ of the pixel matrix $P_{\{n,m}\}$ are electrically coupled to the scanning line G_{n+1} and the data line D_m , respectively;

wherein the gate and the source of the transistor of the second sub-pixel $P_{n,m}(2)$ of the pixel $P_{n,m}$ of the pixel 40

matrix $\{P_{n,m}\}$ are electrically coupled to the scanning line G_n and the sub-pixel electrode of the first sub-pixel $P_{n,m}(1)$, respectively;

wherein the gate and the source of the transistor of the first sub-pixel $P_{n+1,m}(1)$ of the pixel $P_{n+1,m}$ of the pixel matrix $\{P_{n,m}\}$ are electrically coupled to the scanning line G_{n+1} and the sub-pixel electrode of the second sub-pixel $P_{n+1,m}(2)$, respectively; and

wherein the gate and the source of the transistor of the second sub-pixel $P_{n+1,m}(2)$ of the pixel $P_{n+1,m}$ of the pixel matrix $\{P_{n,m}\}$ are electrically coupled to the scanning line G_{n+2} and the data line D_{m+1} , respectively.

38. The LCD panel of claim 32, further comprising:

(a) a gate driver for generating a plurality of scanning signals respectively applied to the plurality of scanning lines $\{G_n\}$, wherein the plurality of scanning signals is configured to turn on the switching elements connected to the plurality of scanning lines $\{G_n\}$ in a predefined sequence; and

(b) a data driver for generating a plurality of data signals respectively applied to the plurality of data lines $\{D_m\}$, wherein the plurality of data signals is configured such that any two neighboring data signals have inverted polarities.

39. The LCD panel of claim 38, wherein, in operation, the plurality of pixels $\{P_{n,m}\}$ has a pixel polarity that is in a dot inversion.

40. The LCD panel of claim 32, further comprising a plurality of touch sensing signal lines $\{L_k\}$, $k=1, 2, \dots, K$, K being an integer greater than zero, each being arranged adjacent and parallel to a scanning line G_n or a data line D_m . 30

41. The LCD panel of claim 40, wherein each pixel in the even number pixel rows of the pixel matrix or each pixel in the odd number pixel rows of the pixel matrix further comprises a photo sensor (PS) and a transistor having a gate electrically connected to one of two corresponding scanning lines defining the pixel, a source electrically connected the photo sensor and a drain electrically connected to a corresponding touch sensing signal line. 35

* * * * *

UNITED STATES PATENT AND TRADEMARK OFFICE
CERTIFICATE OF CORRECTION

PATENT NO. : 7,567,228 B1
APPLICATION NO. : 12/204443
DATED : July 28, 2009
INVENTOR(S) : Yi-Chien Wen et al.

Page 1 of 2

It is certified that error appears in the above-identified patent and that said Letters Patent is hereby corrected as shown below:

Column 2, line 15, "G_[n]" should read: --G_[n+1]--

Column 3, line 55, "D_[mm+1]" should read: --D_[m+1]--

Column 4, line 32, "P_{{n},m}" should read: --P_[{n},m]--

Column 5, line 8, "G_[n+]" should read: --G_[n+1]--

Column 5, line 41, "G_[n-1]" should read: --G_[n+1]--

Column 5, line 49, "P_{[{n}]m}" should read: --P_[{n},m]--

Column 10, line 42, "P_{[1],o}" should read: --P_[1,0]--

Column 10, line 50, "P_[1]" should read: --P_[1,1]--

Column 16, line 56, "P_{{n},m-1} and P_{{n},m}" should read: --P_[{n},m-1] and P_[{n},m]--

Column 18, line 34, "P_{[n+1,m](1)}" should read: --P_{[n, m](1)}--

Column 18, line 36, "P_{[n-1,m]m(1)} of the pixel P_[n-1,m]" should read: --P_{[n+1,m](1)} of the pixel P_[n+1,m]--

Column 18, line 42, "G_[n-2]" should read: --G_[n+2]--

Column 18, line 43, "D_[m-1]" should read: --D_[m+1]--

Column 18, line 59, "T_[j-1]" should read: --T_[j+1]--

Signed and Sealed this
First Day of February, 2011

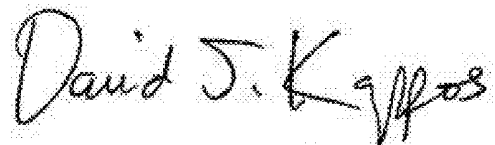

David J. Kappos
Director of the United States Patent and Trademark Office

CERTIFICATE OF CORRECTION (continued)

U.S. Pat. No. 7,567,228 B1

Column 20, line 2, "D_[m-1]" should read: --D_[m+1]--

Column 20, line 37, "P_{[n,m](1)}" should read: --P_{[n,m](2)}--

Column 20, line 55, "P_[n-1,m]" should read: --P_[n+1,m]--

Column 20, line 58, "P_{[n-1,m](2)}" should read: --P_{[n+1,m](2)}--

Column 21, line 38, "P_[n-1,m]" should read: --P_[n+1,m]--

Column 21, line 43, "P_[n-1,m]" should read: --P_[n+1,m]--

Column 22, line 67, "P_[n,{n}]" should read: --P_[n,{m}]--

Column 23, line 38, "P_{[n,m]}" should read: --{P_{[n,m]}}--

Column 24, line 5, "P_[n-1,m]" should read: --P_[n+1,m]--

Column 24, line 8, "P_{[n-1,m](2)}" should read: --P_{[n+1,m](2)}--

专利名称(译)	采用列反转数据驱动的多开关像素设计		
公开(公告)号	US7567228	公开(公告)日	2009-07-28
申请号	US12/204443	申请日	2008-09-04
[标]申请(专利权)人(译)	友达光电股份有限公司		
申请(专利权)人(译)	友达光电股份有限公司		
当前申请(专利权)人(译)	友达光电股份有限公司		
[标]发明人	WEN YI CHIEN LU CHAO LIANG CHEN KEN MING HUNG CHI MAO LI CHUN HUAI KUO JING TIN SU CHANG WEI HSIEH YAO JEN		
发明人	WEN, YI-CHIEN LU, CHAO-LIANG CHEN, KEN-MING HUNG, CHI-MAO LI, CHUN-HUAI KUO, JING-TIN SU, CHANG-WEI HSIEH, YAO-JEN		
IPC分类号	G09G3/36		
CPC分类号	G09G3/3614 G09G2330/021 G09G2310/02 G09G2300/0426		
审查员(译)	SHANKAR , VIJAY		
外部链接	Espacenet USPTO		

摘要(译)

一种具有降低功耗的液晶显示 (LCD) 面板及其驱动方法。在一个实施例中，LCD面板包括像素矩阵，多条扫描线和多条数据线。每对两条相邻扫描线在它们之间限定像素行，并且每对两条相邻数据线在它们之间限定像素列。每个像素至少具有第一子像素和第二子像素。每个子像素具有子像素电极和电耦合到子像素电极的开关元件。每对两条相邻的扫描线分别电耦合到像素行中的每个像素的第一子像素和第二子像素的开关元件。每条数据线都是电耦合到与数据线相关联的两个相邻像素列中的一个的每个奇数像素的第一子像素或第二子像素的开关元件以及第二子像素或第一子像素的开关元件。两个相邻像素列中的另一个的每个偶数像素的像素。LCD面板还包括栅极驱动器和数据驱动器，用于分别产生施加到多条扫描线和多条数据线的扫描信号和数据信号。扫描信号被配置为以预定顺序接通连接到多条扫描线的开关元件，并且数据信号被配置为使得任何两个相邻数据信号已经被反转极性。

