



US 20040239846A1

(19) **United States**

(12) **Patent Application Publication**

(10) **Pub. No.: US 2004/0239846 A1**

Wen et al.

(43) **Pub. Date:**

Dec. 2, 2004

(54) **TRANSFLECTIVE LIQUID CRYSTAL DISPLAY**

Publication Classification

(51) **Int. Cl.⁷** G02F 1/1335

(76) **Inventors:** Chi-Jain Wen, Hsin-Chu City (TW);
Dai-Liang Ting, Hsin-Chu City (TW);
Hsiao-Yi Lin, Hsin-Chu City (TW);
Gwo-Long Lin, Hsin-Chu City (TW);
I-Wei Wu, Hsin-Chu City (TW)

(52) **U.S. Cl.** 349/114

(57) **ABSTRACT**

Correspondence Address:
**NAIPO (NORTH AMERICA
INTERNATIONAL PATENT OFFICE)
P.O. BOX 506
MERRIFIELD, VA 22116 (US)**

A transfective liquid crystal display (LCD) includes at least a transmission pixel region and at least a reflection pixel region positioned in a pixel region. The transmission region includes at least a transmissive electrode connected to a first switching element. The reflection pixel region includes at least a reflective electrode connected to a second switching element. The transmissive and the reflective electrodes are controlled respectively by independent switching elements.

(21) **Appl. No.:** 10/250,018

(22) **Filed:** May 29, 2003

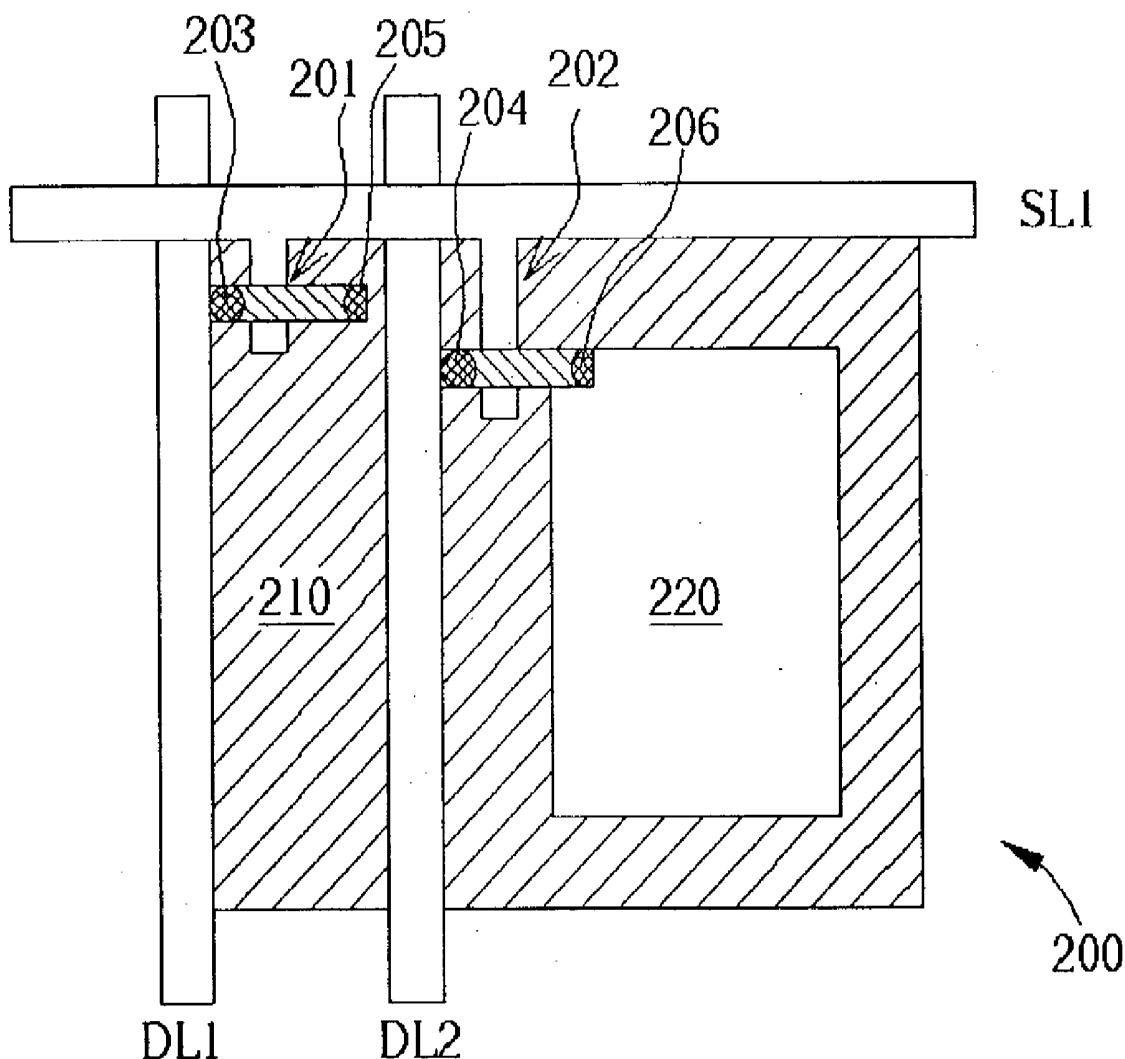

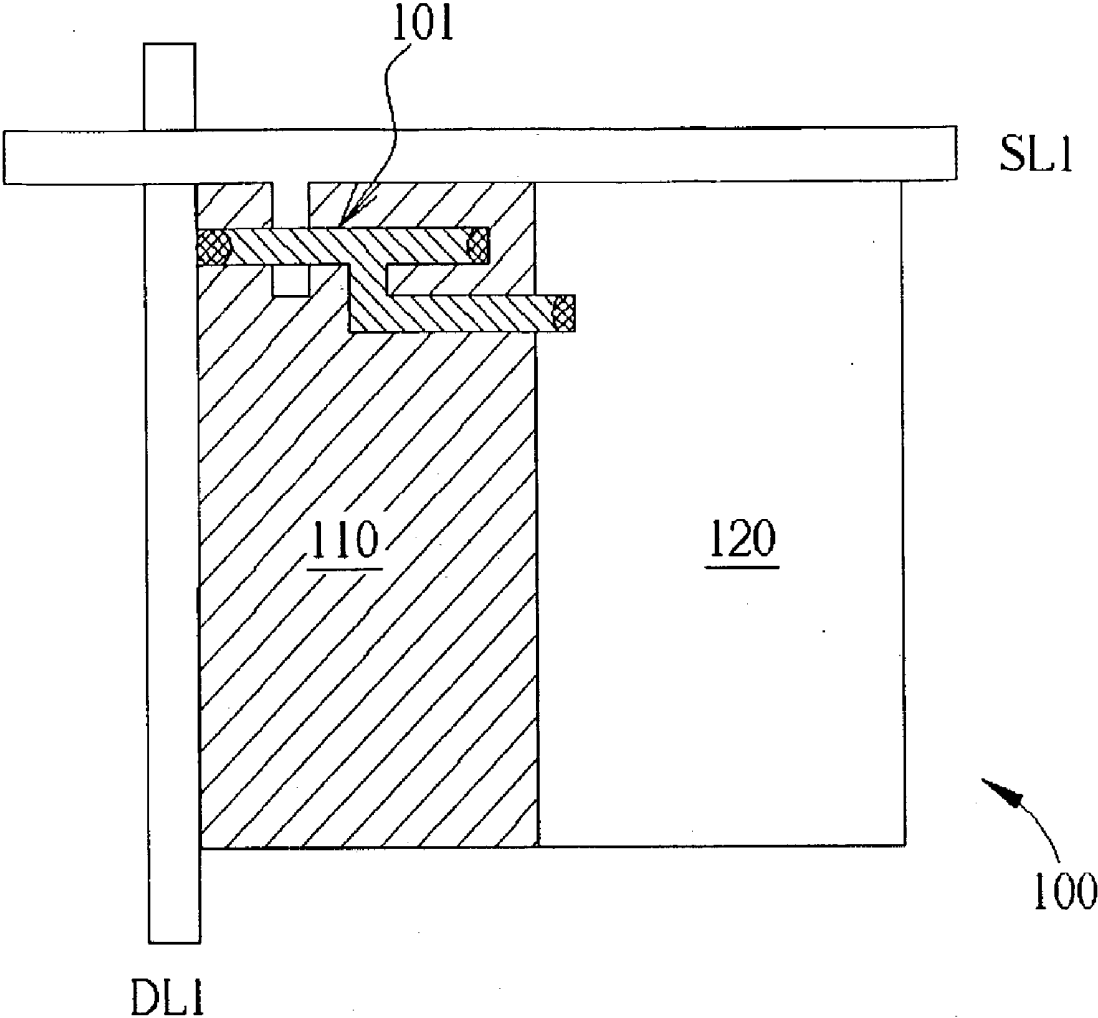

Fig. 1 Prior art

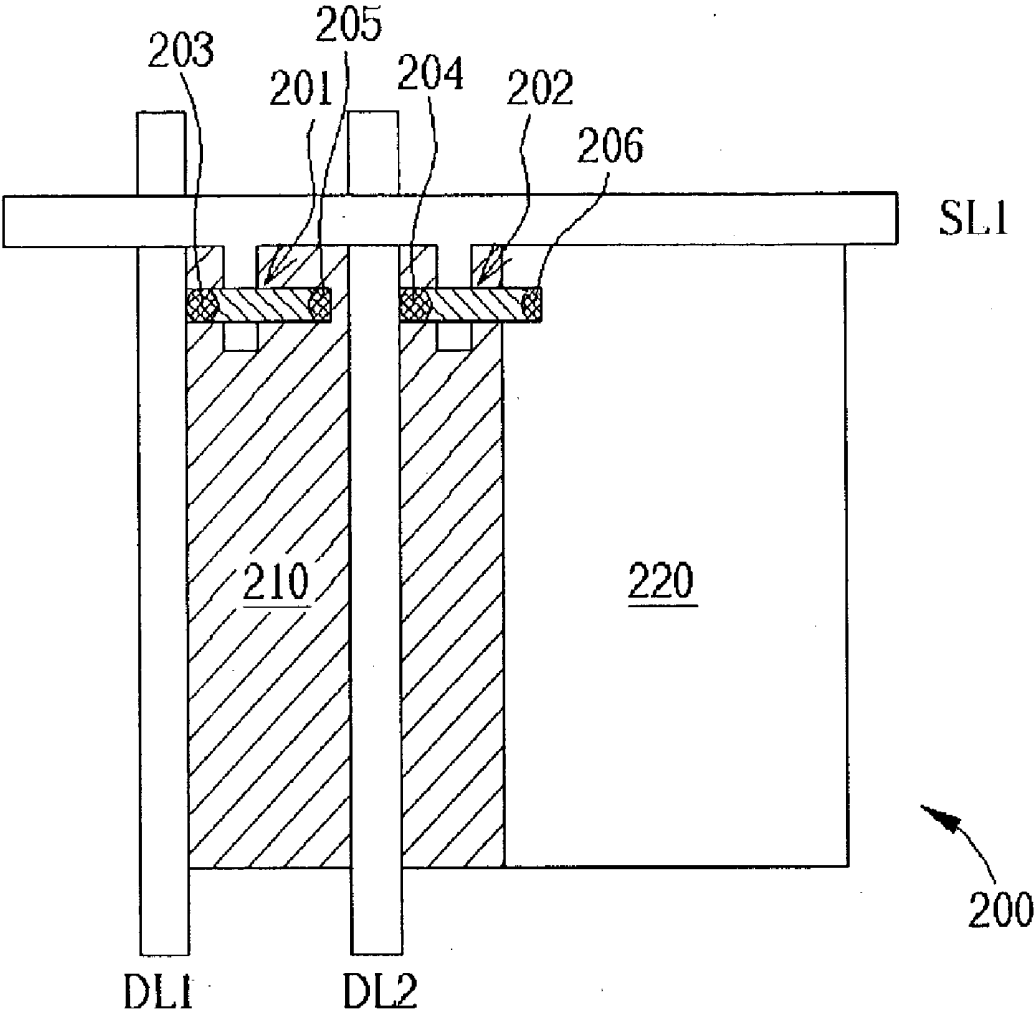

Fig. 2

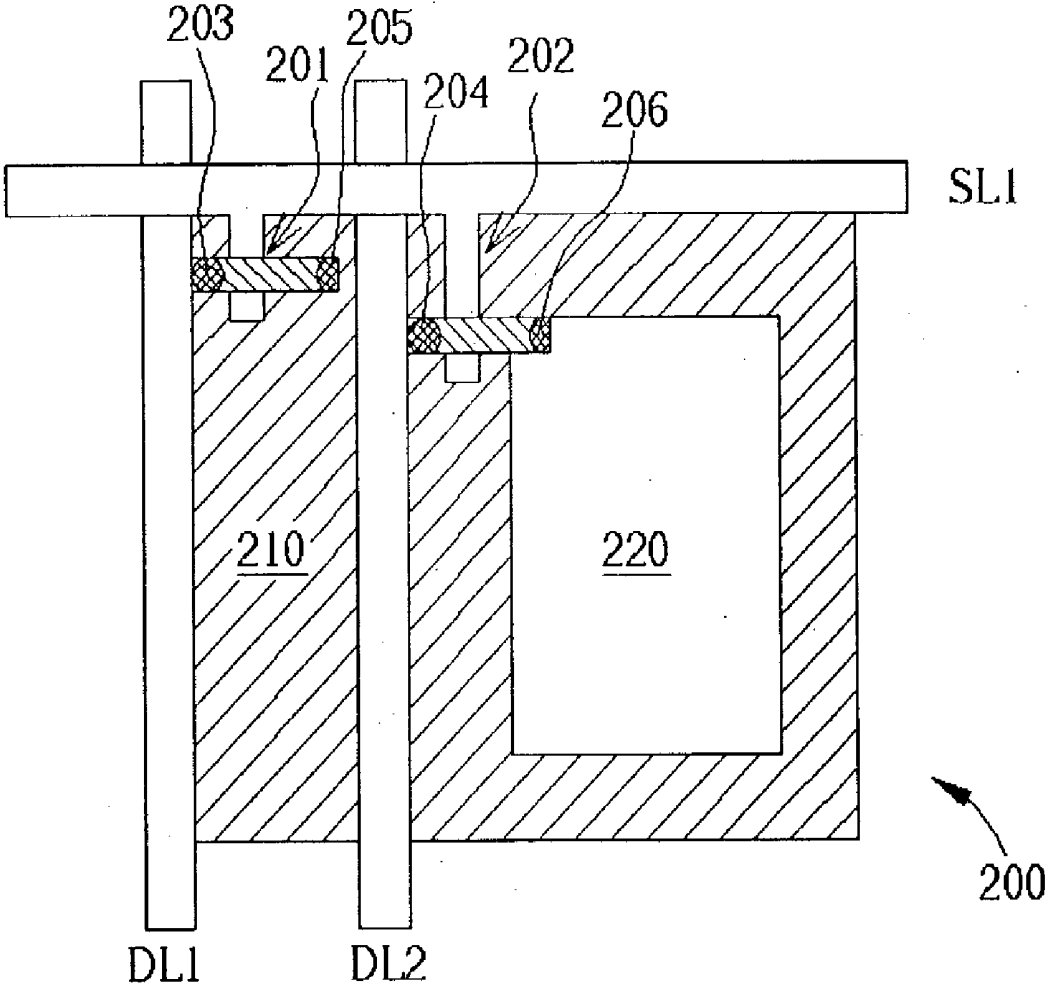

Fig. 3

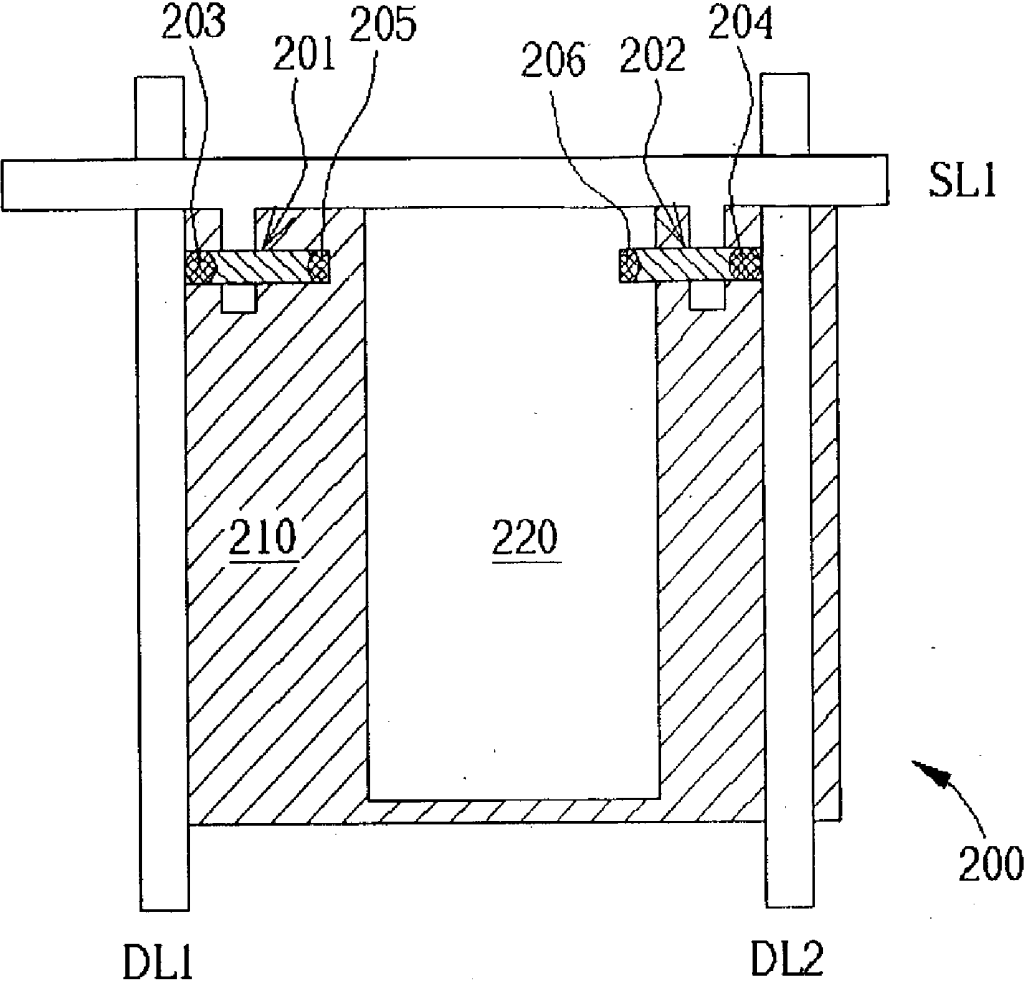

Fig. 4

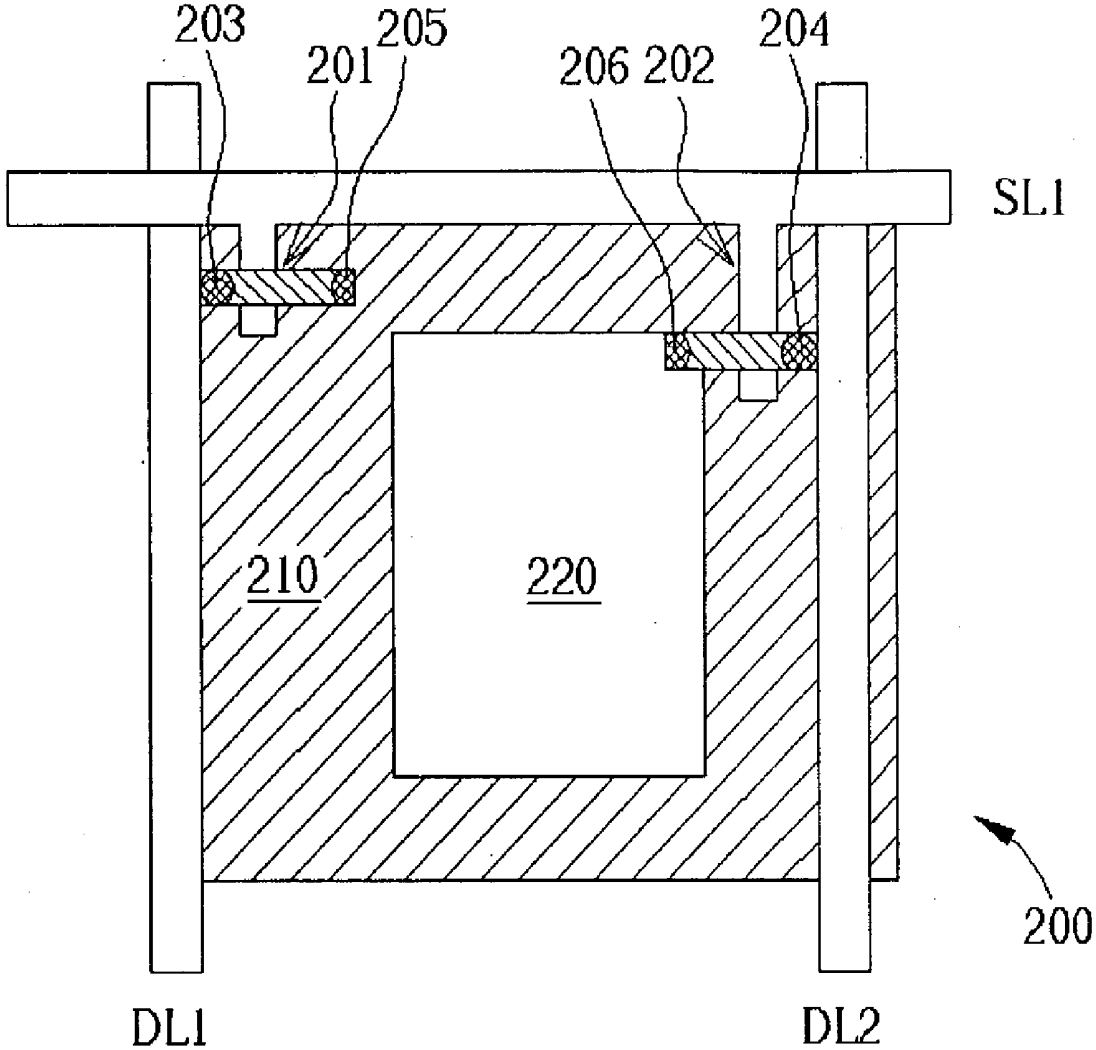

Fig. 5

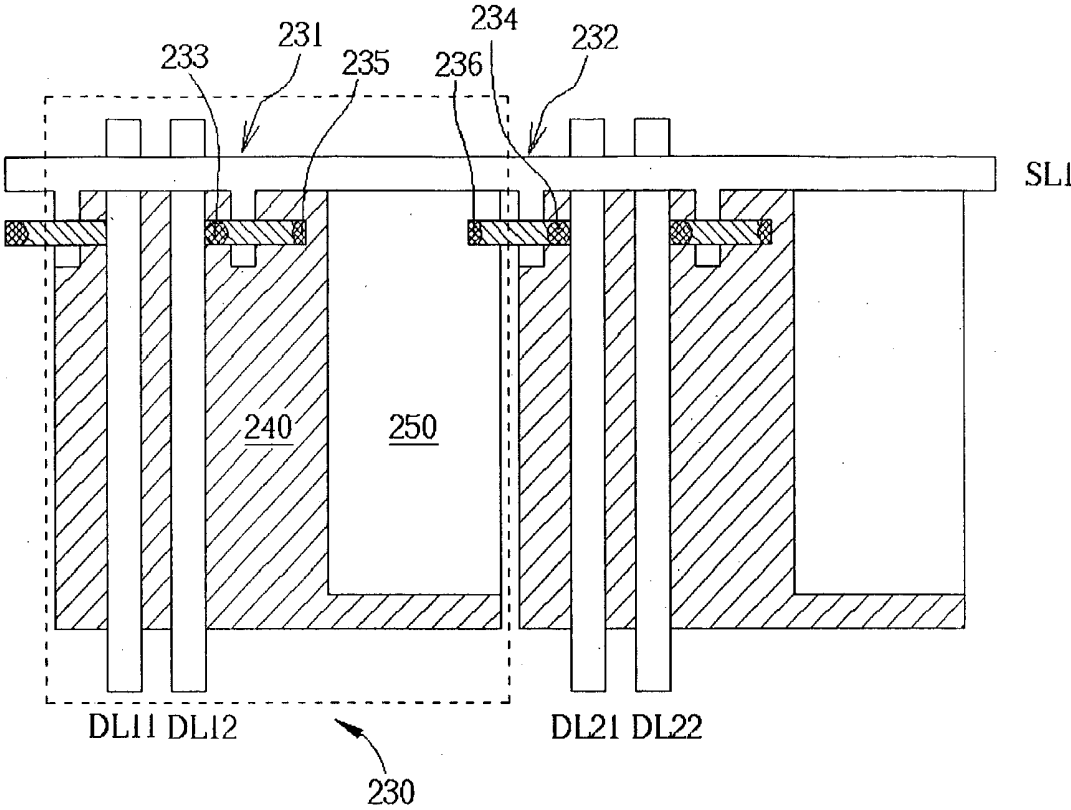

Fig. 6

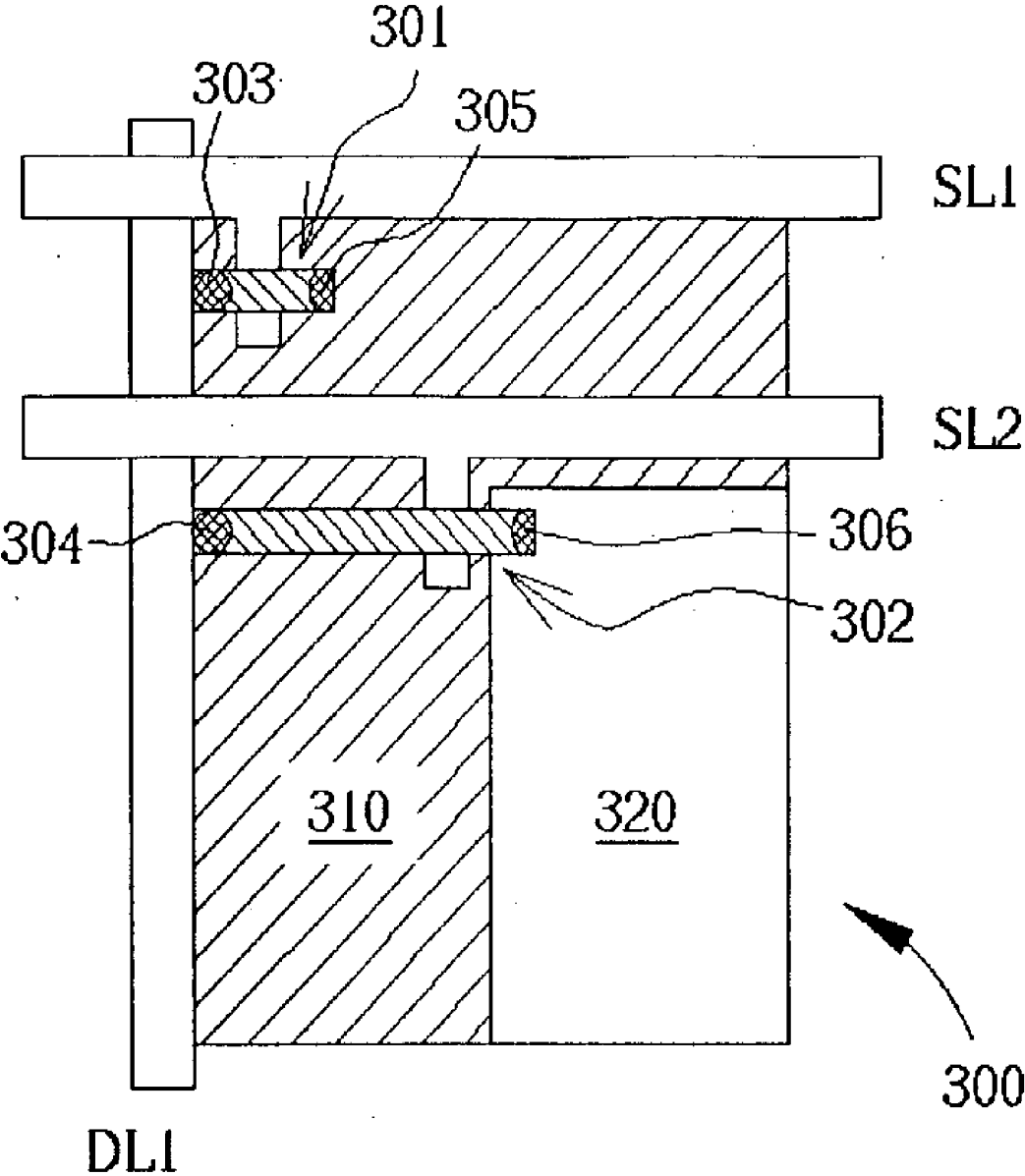

Fig. 7

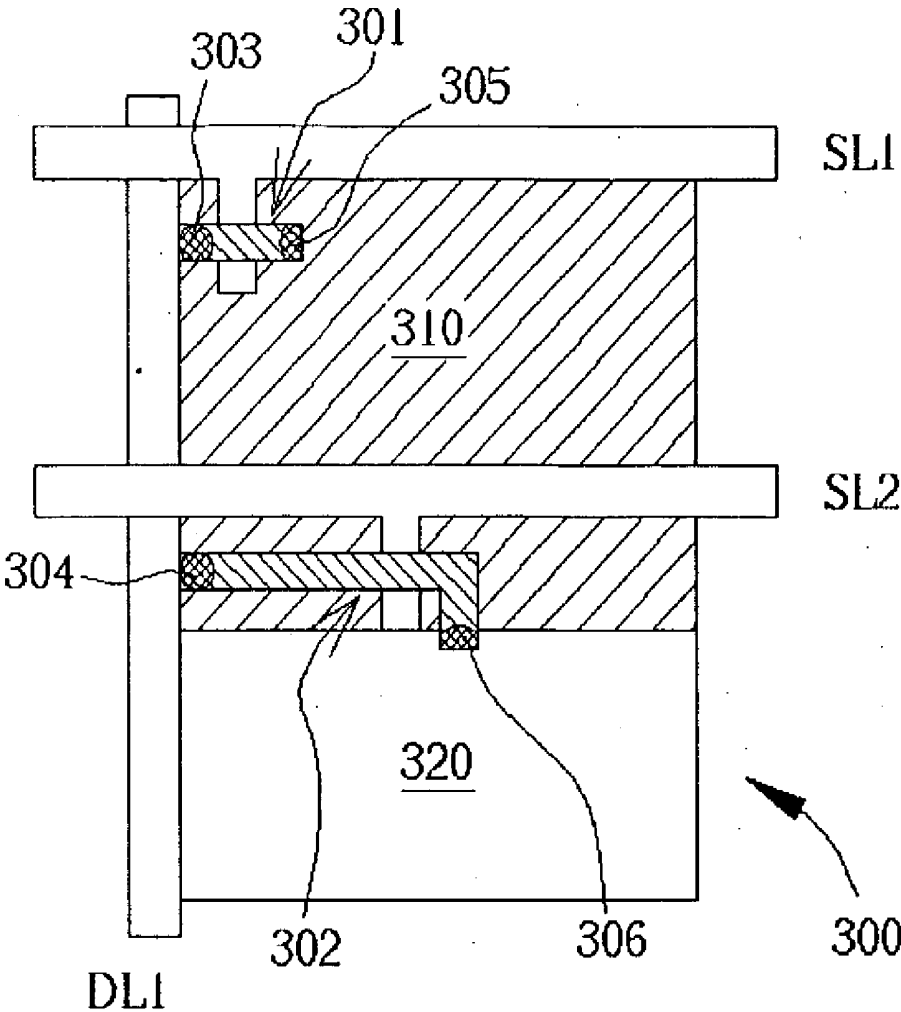

Fig. 8

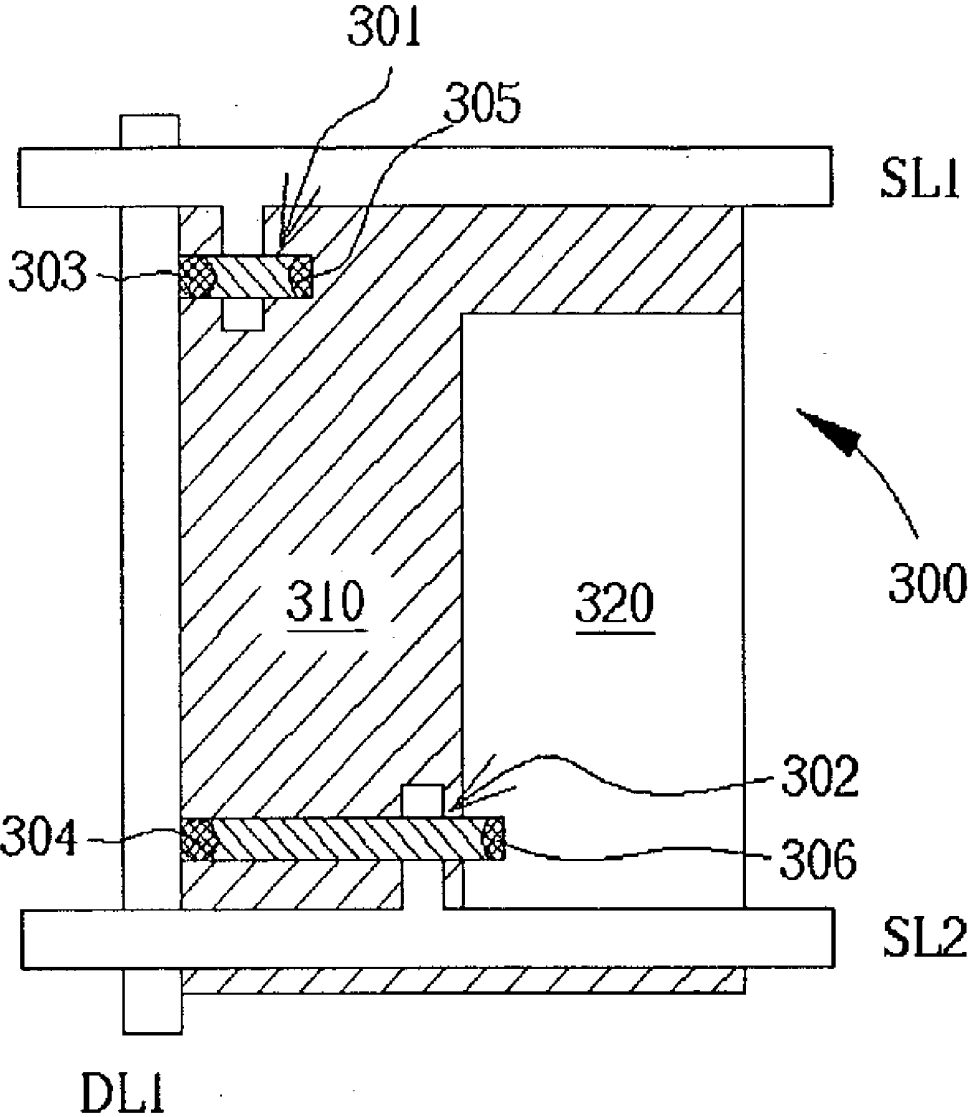

Fig. 9

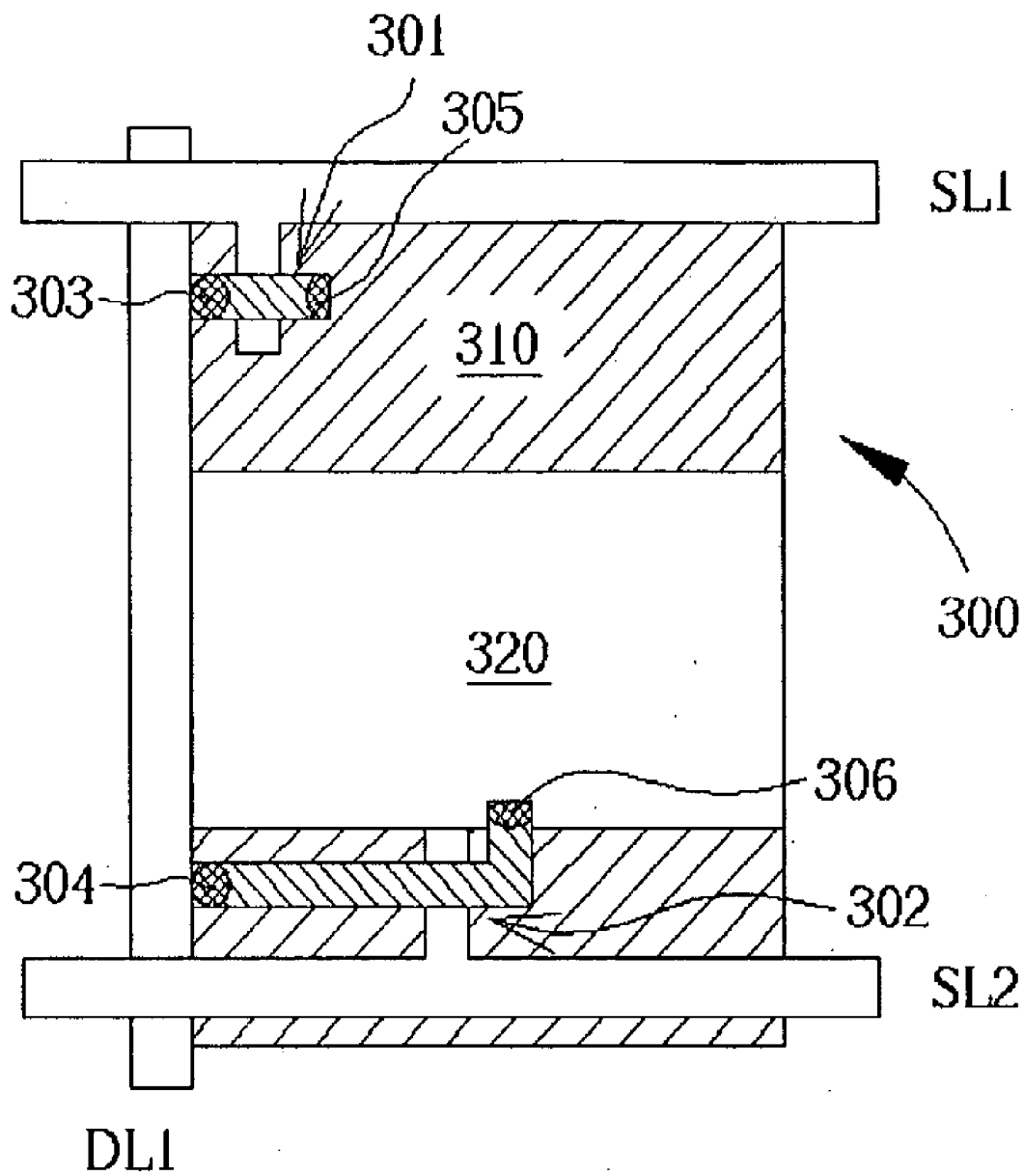

Fig. 10

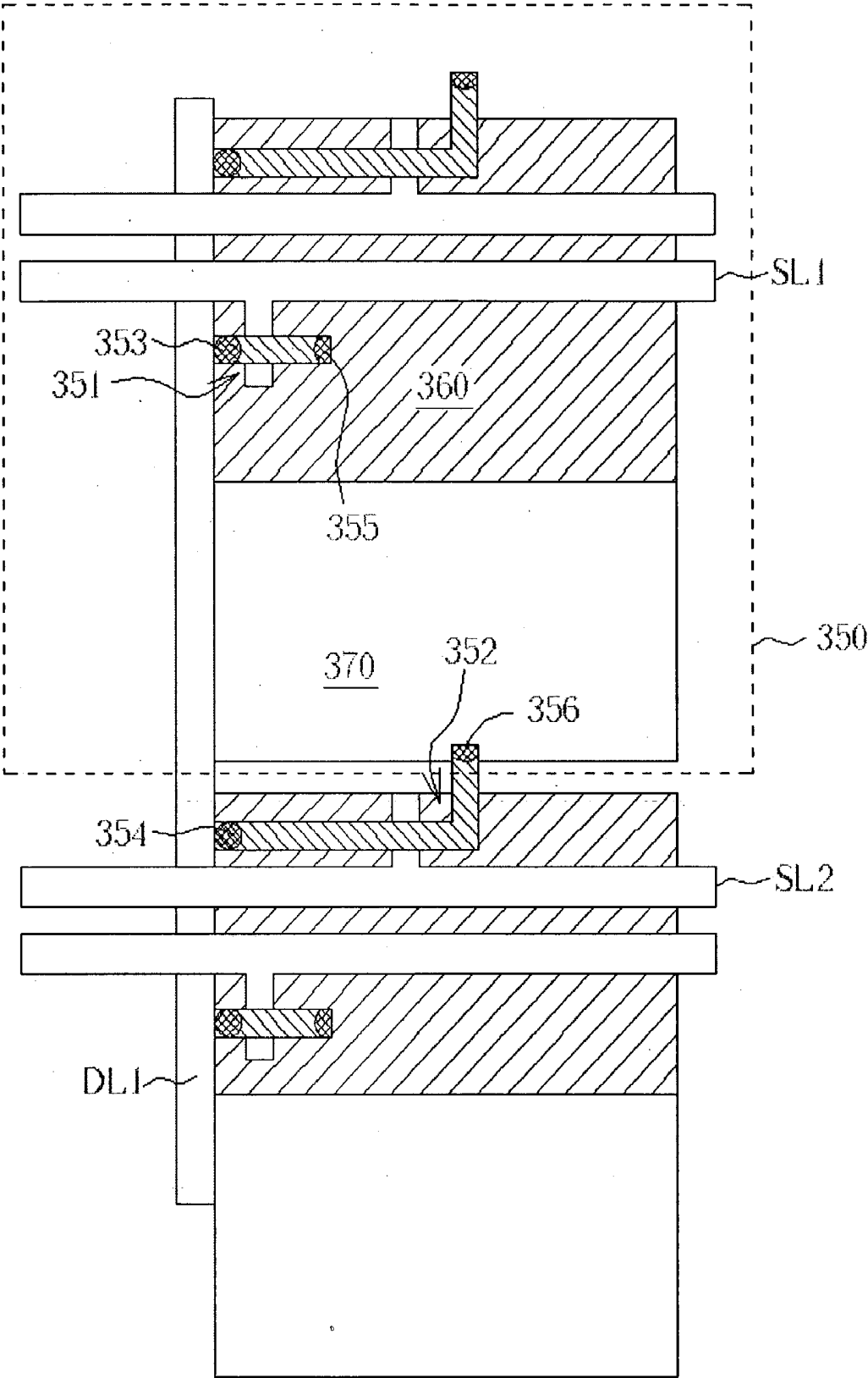

Fig. 11

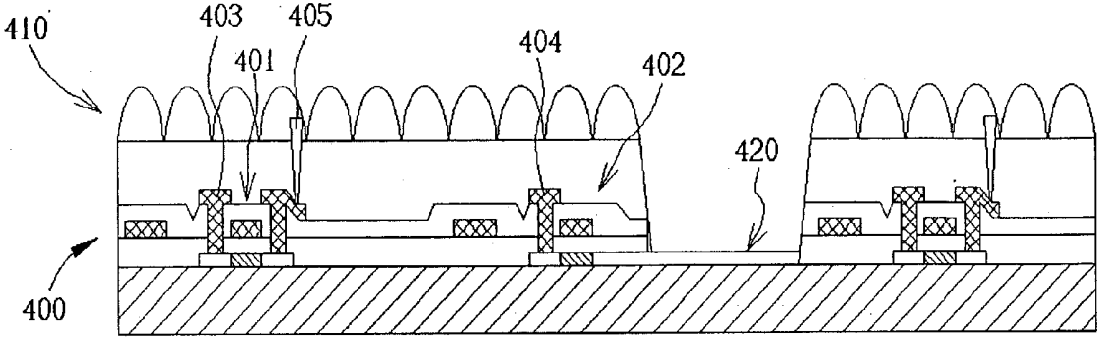

Fig. 12

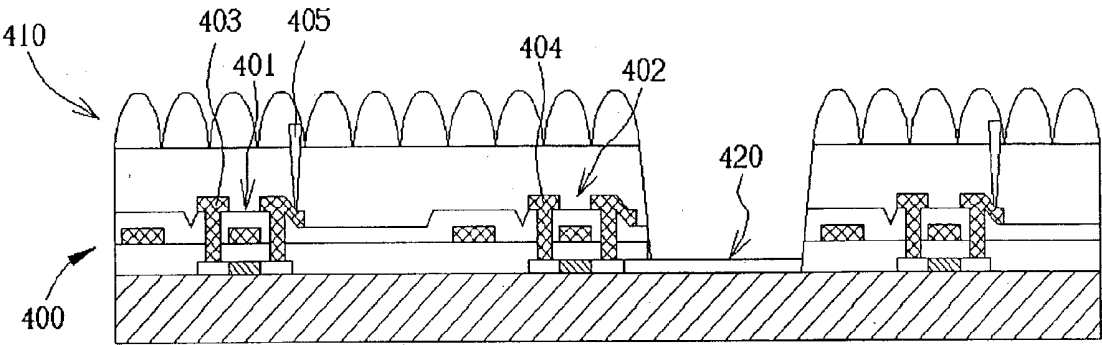

Fig. 13

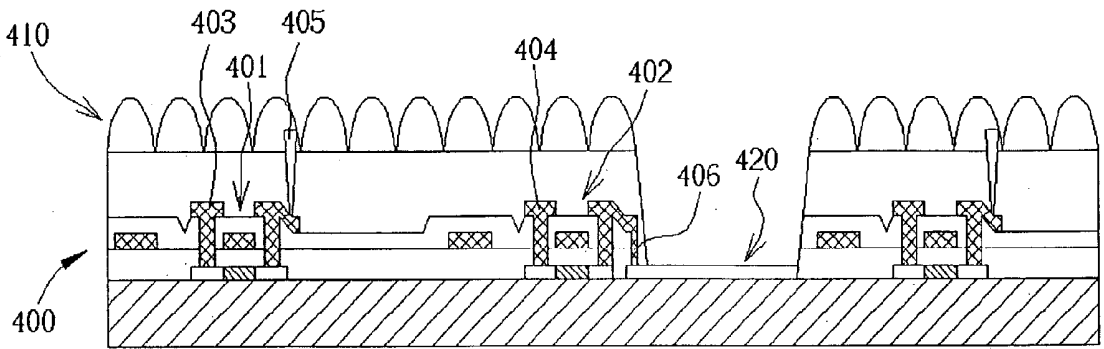

Fig. 14

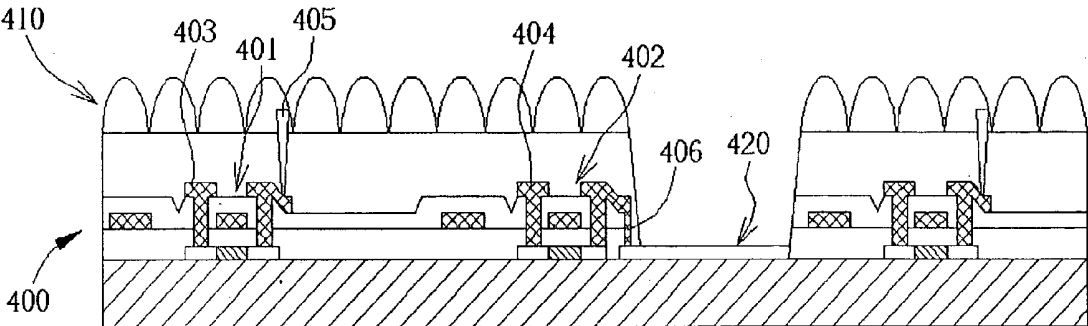

Fig. 15

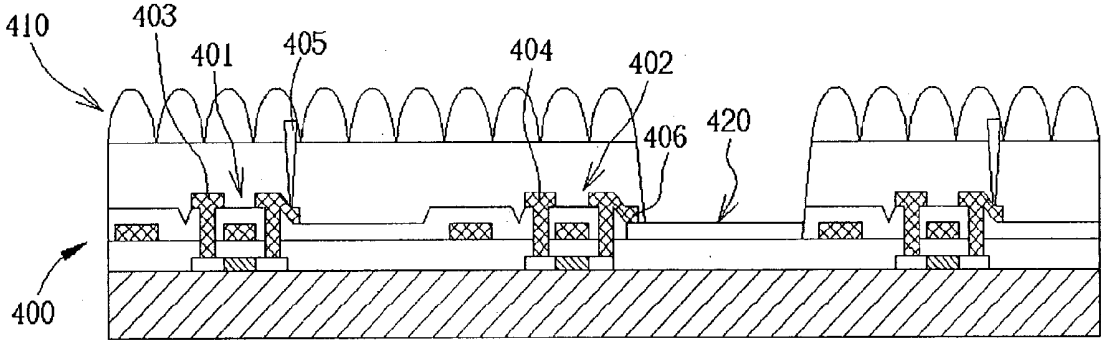

Fig. 16

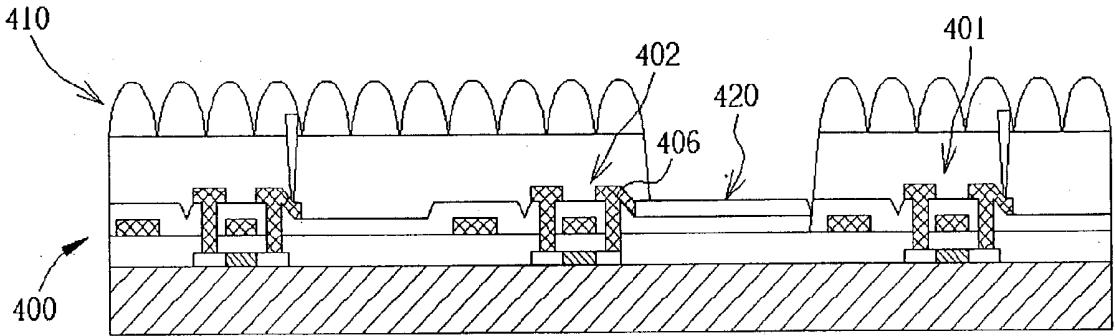

Fig. 17

TRANSFLECTIVE LIQUID CRYSTAL DISPLAY

BACKGROUND OF INVENTION

[0001] 1. Field of the Invention

[0002] The present invention relates to a liquid crystal display (LCD), and more particularly to a transfective LCD.

[0003] 2. Description of the Prior Art

[0004] LCDs have been popularly applied to various IT products such as notebooks, personal digital assistants (PDAs), and cellular phones. Since LCDs are passive luminous devices, an external light source is required. According to different types of external light sources, LCDs are generally classified into reflective LCDs, transmissive LCDs, and transfective LCDs. In a reflective LCD, an external light in front of the panel enters the panel, and is reflected by a reflective layer (such as an aluminum layer) so that users can see what the LCD displays on the screen. In a transmissive LCD, a back light module is installed behind the panel for radiating light, and the radiating light will pass through the panel so that users can see what the LCD displays on the screen. In a transfective LCD, an external light and a back light module are used simultaneously as light sources to illuminate the transfective LCD.

[0005] Please refer to FIG. 1. FIG. 1 is a schematic diagram of a pixel region 100 of a prior art transfective LCD, wherein the pixel region 100 is a red color, green color, or blue color pixel region. As shown in FIG. 1, the pixel region 100 comprises a reflection pixel region 110 and a transmission region 120, wherein the reflection pixel region 110 includes a reflective electrode (not shown), and the transmission pixel region 120 comprises a transmissive electrode (not shown). The transmissive electrode (not shown) and the reflective electrode of a pixel region are connected to a pixel driving circuit 101 controlled by a scan line SL1 and a data line DL1, and the luminance of the transmission pixel and the reflective pixel are controlled by the pixel driving circuit 101 simultaneously.

[0006] The transmission mode of the prior art transfective LCD uses an internal back light module, while the reflection mode uses an external light. However, in the prior art a pixel driving circuit is used to control both a transmission pixel region and a reflection pixel region in the same pixel region, so only the transmission region or the reflection region can be controlled to its best color display. Therefore the total color display of the transfective LCD is reduced.

SUMMARY OF INVENTION

[0007] It is therefore a primary objective of the claimed invention to provide a transfective LCD using two independent switching elements to control the transmission pixel region and the reflection pixel region so that both the transmission mode and the reflection mode can achieve best color display with any light sources.

[0008] According to the claimed invention, the transfective LCD comprises a reflection region and a transmission region installed in a pixel region. The reflection region includes a reflective electrode connected to a first switching element, and the transmission region comprises a transmissive electrode connected to a second switching element,

wherein the first switching element and the second switching element respectively control the function of reflection mode and transmission mode.

[0009] It is an advantage of the claimed invention that the best color display of the transfective LCD can be achieved because the luminance of the reflection region and the transmission region are controlled separately by the first switching element and the second switching element.

[0010] These and other objectives of the present invention will no doubt become obvious to those of ordinary skill in the art after having read the following detailed description of the preferred embodiment that is illustrated in the various figures and drawings.

BRIEF DESCRIPTION OF DRAWINGS

[0011] FIG. 1 is a schematic diagram of a pixel region of a prior art transfective LCD.

[0012] FIG. 2 to FIG. 5 are schematic diagrams of a pixel region of a transfective LCD along the radiation direction of a back light module in the first embodiment of the present invention.

[0013] FIG. 6 is a schematic diagram of a pixel region of a transfective LCD along the radiation direction of a back light module in the second embodiment of the present invention.

[0014] FIG. 7 to FIG. 10 are schematic diagrams of a pixel region of a transfective LCD along the radiation direction of a back light module in the third embodiment of the present invention.

[0015] FIG. 11 is a schematic diagram of a pixel region of a transfective LCD along the radiation direction of a back light module in the fourth embodiment of the present invention.

[0016] FIG. 12 to FIG. 17 are cross-section diagrams of a transfective LCD of the present invention.

DETAILED DESCRIPTION

[0017] Please refer to FIG. 2. FIG. 2 is a schematic diagram of a pixel region 200 of a transfective LCD along the radiation direction of a back light module in the first embodiment of the present invention, wherein the pixel region 200 is a red color pixel region, a green color pixel region, or a blue color pixel region. As shown in FIG. 2, the pixel region 200 includes a reflection region 210 and a transmission region 220, the luminance of the reflection region 210 is controlled by a first switching element 201, and the luminance of the transmission region 220 is controlled by a second switching element 202. The switching elements 201 and 202 can be driving circuits sharing a scan line SL1, connect to data lines DL1 and DL2 by contact holes 203 and 204, and receive image data signals from data lines DL1 and DL2 respectively. Furthermore, the first switching element 201 is connected to a reflective electrode (not shown) by a contact hole 205 for controlling the luminance of the reflection region 210, and the second switching element 202 is connected to a transmissive electrode (not shown) by a contact hole 206 for controlling the luminance of the transmission region 220. In this embodiment of the present invention, the data line DL1, DL2 and the switching element 201, 202 are located below the

reflection region **210** for not affecting the aperture ratio. It is worth noticing that the relative location and ratio of the reflection pixel region and the transmission pixel region can be modified according to circuit designs as shown in **FIG. 3**, **FIG. 4**, and **FIG. 5**.

[0018] Please refer to **FIG. 6**. **FIG. 6** is a schematic diagram of a pixel region **230** of a transfective LCD along the radiation direction of a back light module in the second embodiment of the present invention, wherein the pixel region **230** is a red color pixel region, a green color pixel region, or a blue color pixel region. As shown in **FIG. 6**, the pixel region **230** includes a reflection region **240** and a transmission region **250**, the luminance of the reflection region **230** is controlled by a first switching element **231**, and the luminance of the transmission region **250** is controlled by a second switching element **232**. The switching elements **231** and **232** are driving circuits sharing a scan line **SL1**, connect to data lines **DL12** and **DL21** by contact holes **233** and **234**, and receive image data signals from data lines **DL12** and **DL21** respectively. Furthermore, the first switching element **231** is connected to a reflective electrode (not shown) by a contact hole **235** for controlling the luminance of the reflection region **240**, and the second switching element **232** is connected to a transmissive electrode (not shown) by a contact hole **236** for controlling the luminance of the transmission region **250**. In this embodiment of the present invention, the data line **DL12** and the first switching element **231** are located below the reflection region **240**, while the data line **DL21** and the second switching element **232** are located below a reflection pixel region of a neighboring pixel region for not affecting the aperture ratio.

[0019] Please refer to **FIG. 7**. **FIG. 7** is a schematic diagram of a pixel region **300** of a transfective LCD along the radiation direction of a back light module in the third embodiment of the present invention, wherein the pixel region **300** is a red color pixel region, a green color pixel region, or a blue color pixel region. As shown in **FIG. 7**, the pixel region **300** includes a reflection region **310** and a transmission region **320**, the luminance of the reflection region **310** is controlled by a first switching element **301**, and the luminance of the transmission region **320** is controlled by a second switching element **302**. The switching elements **301** and **302** are respectively connected to a data line **DL1** by contact holes **303** and **304**. Furthermore, the first switching element **301** is connected to a reflective electrode (not shown) by a contact hole **305**, and the reflective electrode (not shown) receives a signal from the scan line **SL1** to switch the reflection region **310**. The second switching element **302** is connected to a transmissive electrode (not shown) by a contact hole **306**, and the transmissive electrode (not shown) receives a signal from the scan line **SL2** to switch the transmission region **320**. In this embodiment of the present invention, the scan lines **SL1**, **SL2** and the switching elements **301**, **302** are located below the reflection region **310** for not affecting the aperture ratio. It is worth noticing that the relative location and ratio of the reflection pixel region and the transmission pixel region can be modified according to circuit designs as shown in **FIG. 8**, **FIG. 9**, and **FIG. 10**.

[0020] Please refer to **FIG. 11**. **FIG. 11** is a schematic diagram of a pixel region **350** of a transfective LCD along the radiation direction of a back light module in the fourth embodiment of the present invention, wherein the pixel

region **350** is a red color pixel region, a green color pixel region, or a blue color pixel region. As shown in **FIG. 11**, the pixel region **350** includes a reflection region **360** and a transmission region **370**, the luminance of the reflection region **360** is controlled by a first switching element **351**, and the luminance of the transmission region **370** is controlled by a second switching element **352**. The switching elements **351** and **352** are respectively connected to a data line **DL1** by contact holes **353** and **354**. Furthermore, the first switching element **351** is connected to a reflective electrode (not shown) by a contact hole **355**, and the reflective electrode (not shown) receives a signal from the scan line **SL1** to switch the reflection region **360**. The second switching element **352** is connected to a transmissive electrode (not shown) by a contact hole **356**, and the transmissive electrode (not shown) receives a signal from the scan line **SL2** to switch the transmission region **370**. In this embodiment of the present invention, the scan lines **SL1** and the first switching element **351** are located below the reflection region **360**, while the scan line **SL2** and the second switching element **352** are located below a reflection pixel region of a neighboring pixel region for not affecting the aperture ratio.

[0021] All embodiments of the present invention can be modified as follows. Please refer to **FIG. 12** to **FIG. 17**. **FIG. 12** to **FIG. 17** are cross-section diagrams of a transfective LCD **400** of the present invention. As shown in **FIG. 12** to **FIG. 14**, the transfective LCD **400** comprises a reflective electrode **410**, a transmissive electrode **420**, a first switching element **401**, and a second switching element **402**. The first switching element **401** is connected to a data line by a via hole **403** and is connected to the reflective electrode **410** by a via hole **405**, and the second switching element **402** is connected to a data line by a via hole **404**. The material of the transmissive electrode **420** can be doped or non-doped polysilicon, or doped or non-doped amorphous silicon. Furthermore, the transmissive electrode **420** can be connected directly to an active layer (source/drain) of the second switching element **402** as shown in **FIG. 12** and **FIG. 13**, or the transmissive electrode **420** can be connected to the active layer of the second switching element **402** by the via hole **406** as shown in **FIG. 14**. Additionally, the transmissive electrode **420** can be an ITO or an IZO material, and is connected to the second switching element **402** by a via hole **406**, wherein the location of the transmissive electrode **420** can be modified as shown in **FIG. 15** to **FIG. 17**. As shown in **FIG. 15**, the transmissive electrode **420** is located on the bottom layer of the second switching element **402**. As shown in **FIG. 16**, the transmissive electrode **420** and the scan line are located in the same layer. As shown in **FIG. 17**, the transmissive electrode **420** and the data line are located in the same layer.

[0022] Those skilled in the art will readily observe that numerous modifications and alterations of the device may be made while retaining the teachings of the invention. Accordingly, the above disclosure should be construed as limited only by the metes and bounds of the appended claims.

What is claimed is:

1. A transfective liquid crystal display (LCD) including at least a reflection region and a transmission region positioned in a pixel region of the transfective liquid crystal display, wherein the reflection region includes at least a reflective electrode connected to a first switching element, and the

transmission region includes at least a transmissive electrode connected to a second switching element.

2. The transfective LCD of claim 1, wherein the pixel region is a red color pixel region.

3. The transfective LCD of claim 1, wherein the pixel region is a green color pixel region.

4. The transfective LCD of claim 1, wherein the pixel region is a blue color pixel region.

5. The transfective LCD of claim 1, wherein the first switching element is used to control a reflection mode of the transfective LCD, and the second switching element is used to control a transmission mode of the transfective LCD.

6. The transfective LCD of claim 5, wherein the reflection mode and the transmission mode are operated individually or cooperatively to achieve best display effect.

7. The transfective LCD of claim 1, wherein the first switching element and the second switching element share a scan line.

8. The transfective LCD of claim 7, wherein the first switching element is connected to a first data line and uses the first data line to send a signal to the reflection region for controlling the brightness of the reflection region, and the second switching element is connected to a second data line and uses the second data line to send a signal to the transmission region for controlling the brightness of the transmission region.

9. The transfective LCD of claim 1, wherein the first switching element and the second switching element share a data line.

10. The transfective LCD of claim 9, wherein the first switching element is connected to a first scan line to send a signal to the reflection region for switching the reflection region, and the second switching element is connected to a

second scan line to send a signal to the transmission region for switching the transmission region.

11. The transfective LCD of claim 1, wherein the second switching element is located under the reflective electrode to avoid affecting the aperture ratio of the transfective LCD.

12. The transfective LCD of claim 1, wherein the reflective electrode includes metal or materials having good conductivity.

13. The transfective LCD of claim 1, wherein the transmissive electrode includes silicon.

14. The transfective LCD of claim 13, wherein the transmissive electrode is connected to an active layer of the second switching element.

15. The transfective LCD of claim 13, wherein the transmissive electrode includes doped polysilicon or doped amorphous silicon.

16. The transfective LCD of claim 1, wherein the transmissive electrode includes non-doped polysilicon or non-doped amorphous silicon.

17. The transfective LCD of claim 1, wherein the transmissive electrode includes ITO (indium tin oxide) or IZO (indium zinc oxide).

18. The transfective LCD of claim 17, wherein the transmissive electrode is located in a bottom layer of the second switching element.

19. The transfective LCD of claim 17, wherein the transmissive electrode and the scan line are located in the same layer.

20. The transfective LCD of claim 17, wherein the transmissive electrode and the data line are located in the same layer.

* * * * *

专利名称(译)	透反液晶显示器		
公开(公告)号	US20040239846A1	公开(公告)日	2004-12-02
申请号	US10/250018	申请日	2003-05-29
[标]申请(专利权)人(译)	蟪纹JAIN 婷戴良 林萧易 LIN GWO LONG 吴魏我		
申请(专利权)人(译)	文智JAIN 寿DAI-LIANG 林孝仪 LIN GWO-LONG 吴I-WEI		
当前申请(专利权)人(译)	文智JAIN 寿DAI-LIANG 林孝仪 LIN GWO-LONG 吴I-WEI		
[标]发明人	WEN CHI JAIN TING DAI LIANG LIN HSIAO YI LIN GWO LONG WU I WEI		
发明人	WEN, CHI-JAIN TING, DAI-LIANG LIN, HSIAO-YI LIN, GWO-LONG WU, I-WEI		
IPC分类号	G02F1/1335 G02F1/1362		
CPC分类号	G02F1/133555 G02F1/13624		
外部链接	Espacenet USPTO		

摘要(译)

透反液晶显示器 (LCD) 至少包括透射像素区域和位于像素区域中的至少一个反射像素区域。透射区域至少包括连接到第一开关元件的透射电极。反射像素区域至少包括连接到第二开关元件的反射电极。透射和反射电极分别由独立的开关元件控制。

