



(19) **United States**

(12) **Patent Application Publication**

Park et al.

(10) **Pub. No.: US 2004/0125315 A1**

(43) **Pub. Date:**

Jul. 1, 2004

(54) **LIQUID CRYSTAL DISPLAY PANEL AND FABRICATING METHOD THEREOF**

Publication Classification

(51) **Int. Cl.⁷** G02F 1/1339

(52) **U.S. Cl.** 349/153

(75) Inventors: **Dae-Lim Park**, Kyongsangbuk-Do (KR); **Seong-Soo Hwang**, Gyoungsangbuk-Do (KR); **Young-Sik Kim**, Kyongsangbuk-Do (KR); **Su-Hwan Moon**, Gyoungsangbuk-Do (KR)

(57) **ABSTRACT**

A liquid crystal display panel includes a first substrate, a second substrate, and a seal pattern. The first substrate has an image display portion thereon, and the seal pattern is along an outer periphery of the image display portion to attach the first substrate with the second substrate. The first substrate includes at least one conductive line disposed at a corner portion of the first substrate, a multi-layer film disposed on the first substrate and the at least one conductive line, and a transparent electrode formed on the multi-layer film and in the bonding holes. The multi-layer film defines a plurality of bonding holes disposed along a region where the seal pattern is disposed. Herein, the transparent electrode is entirely disposed within a boundary defined by an outer side of the seal pattern.

Correspondence Address:
MORGAN LEWIS & BOCKIUS LLP
1111 PENNSYLVANIA AVENUE NW
WASHINGTON, DC 20004 (US)

(73) Assignee: **LG.Philips LCD Co., Ltd.**

(21) Appl. No.: **10/669,014**

(22) Filed: **Sep. 24, 2003**

(30) **Foreign Application Priority Data**

Dec. 31, 2002 (KR) 88460/2002

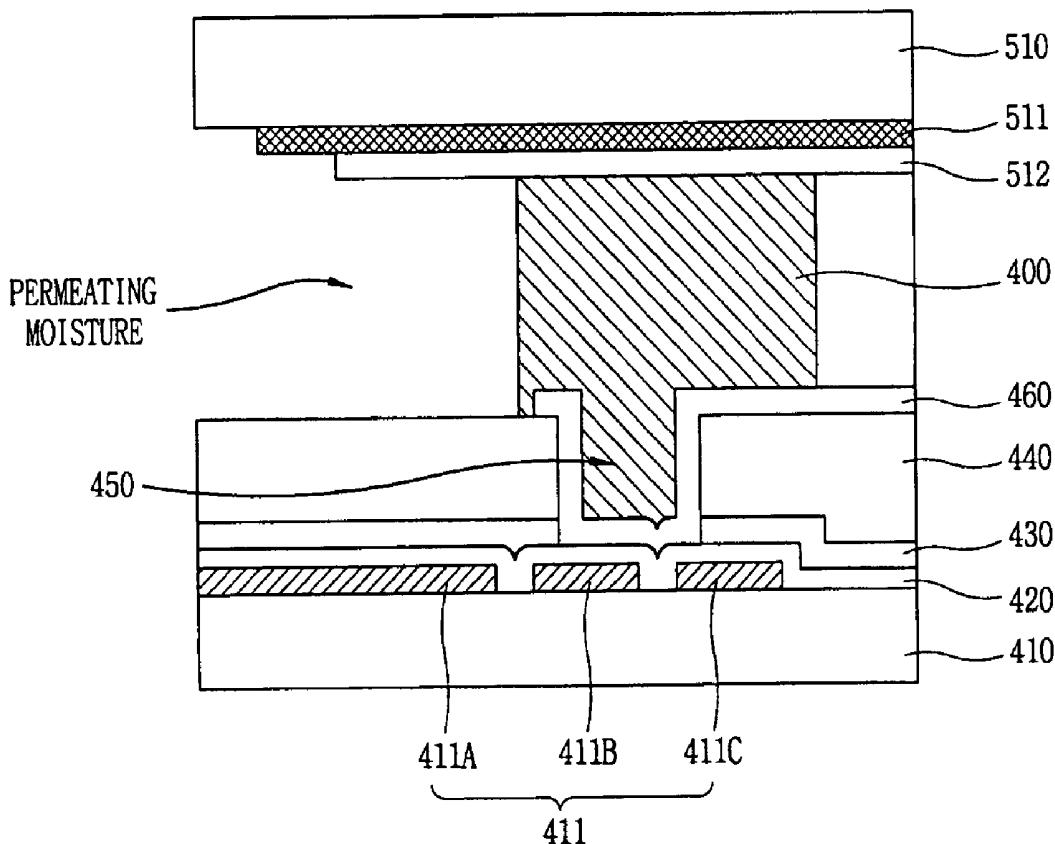

FIG. 1
RELATED ART

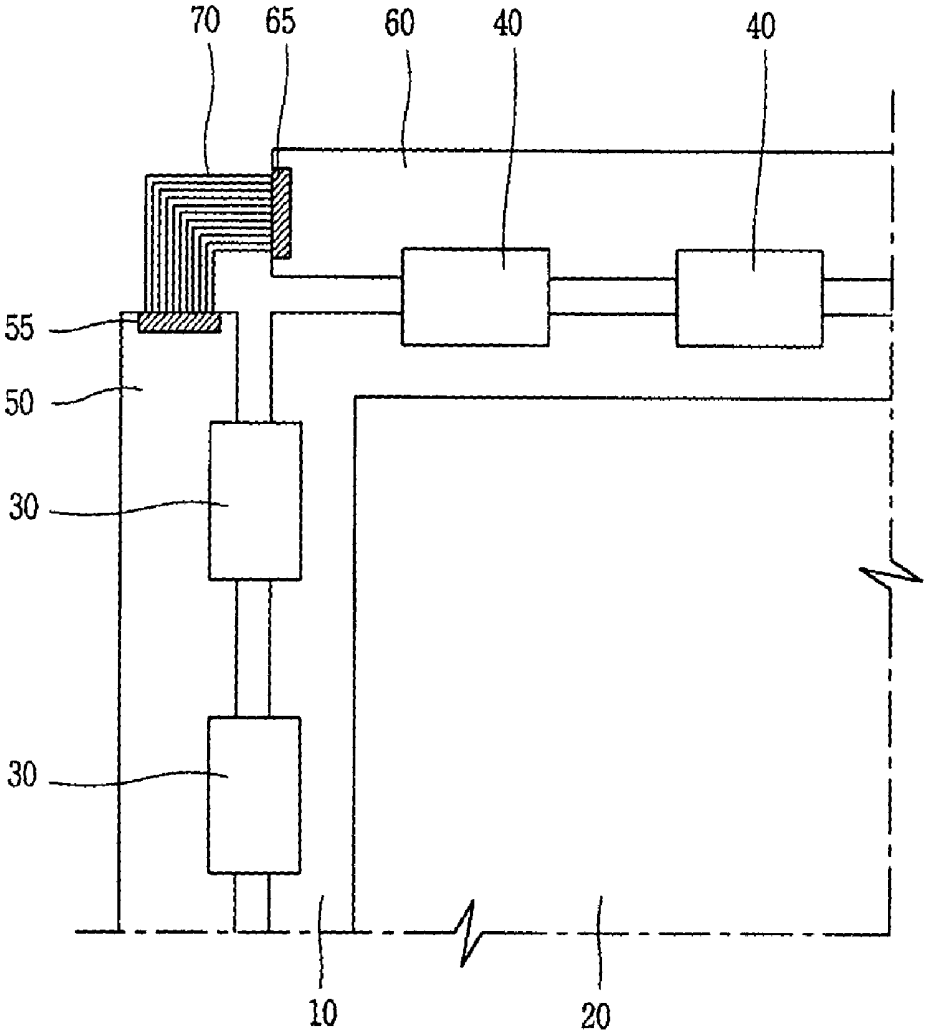

FIG. 2
RELATED ART

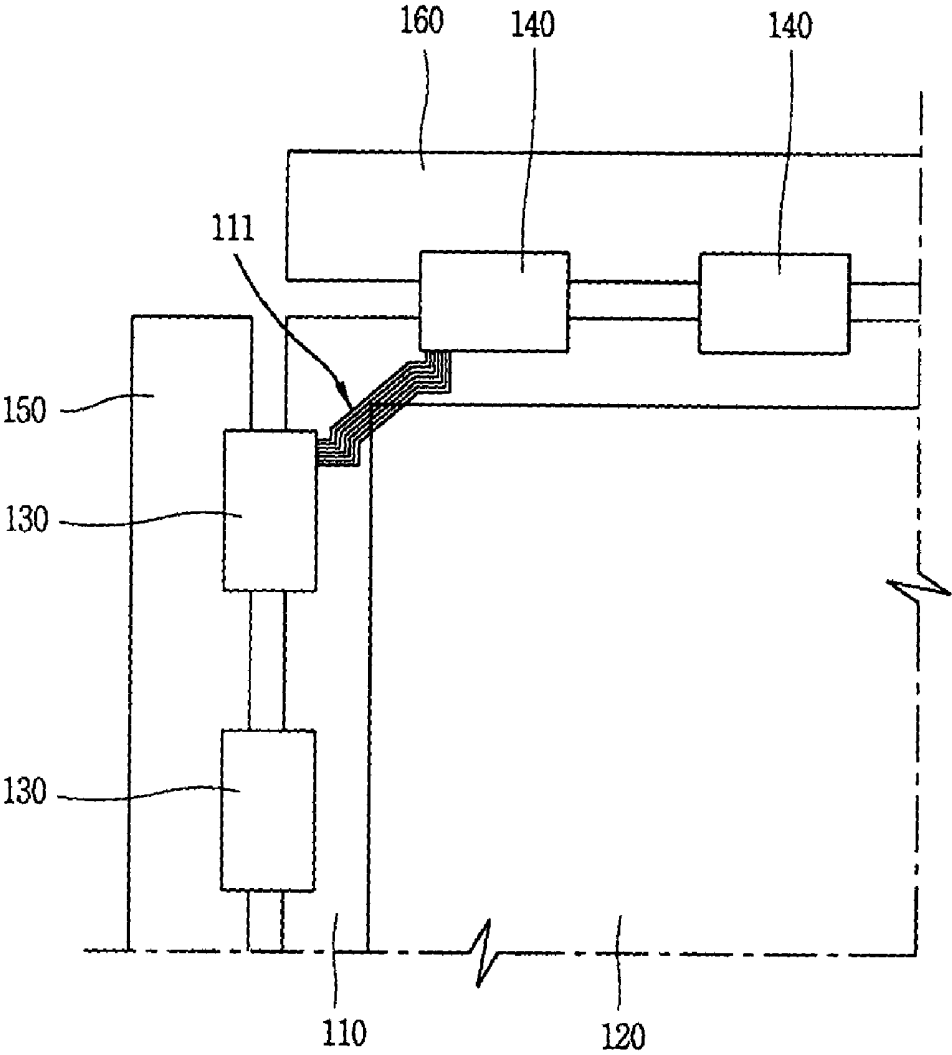

FIG. 3
RELATED ART

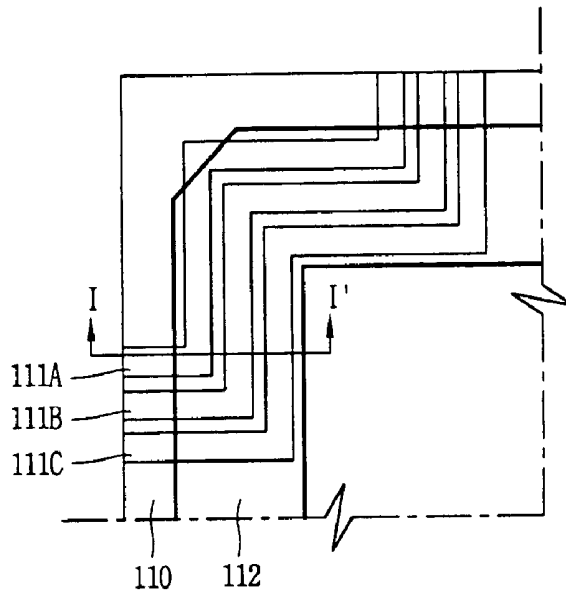

FIG. 4
RELATED ART

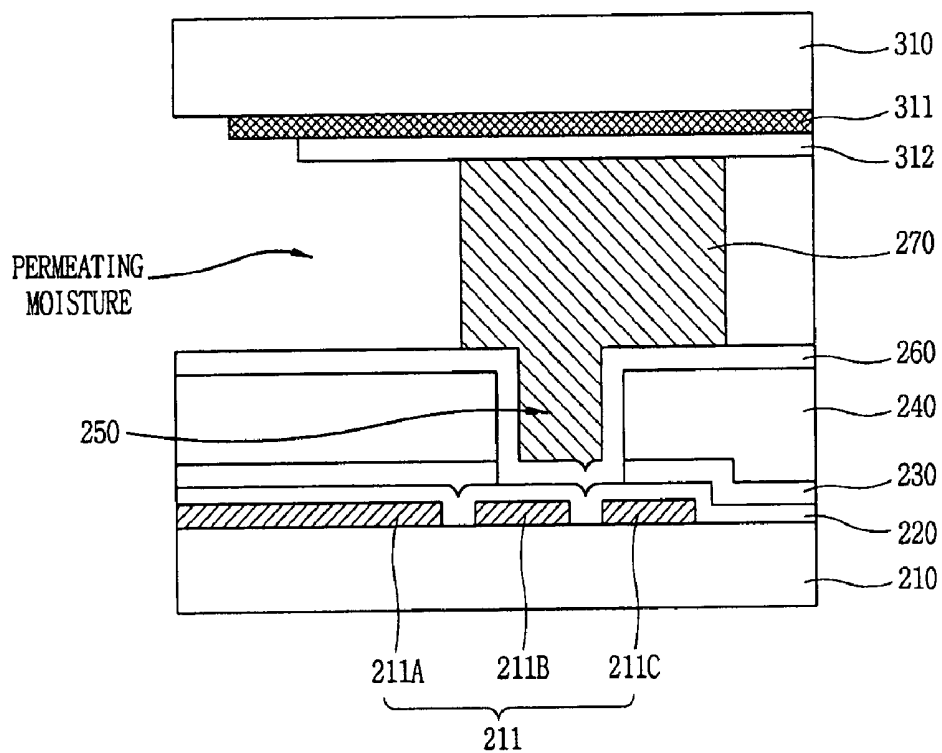

FIG. 5

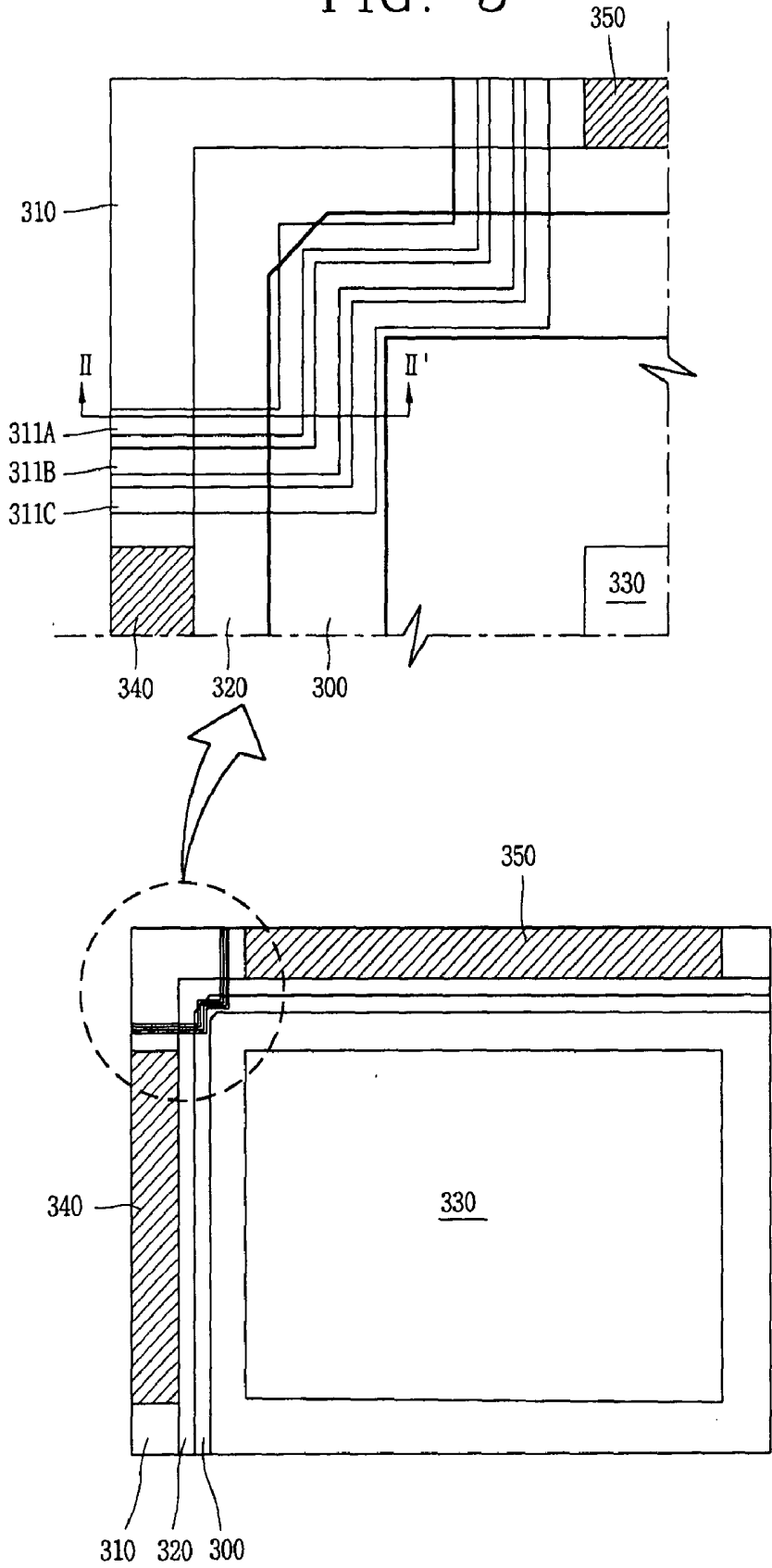
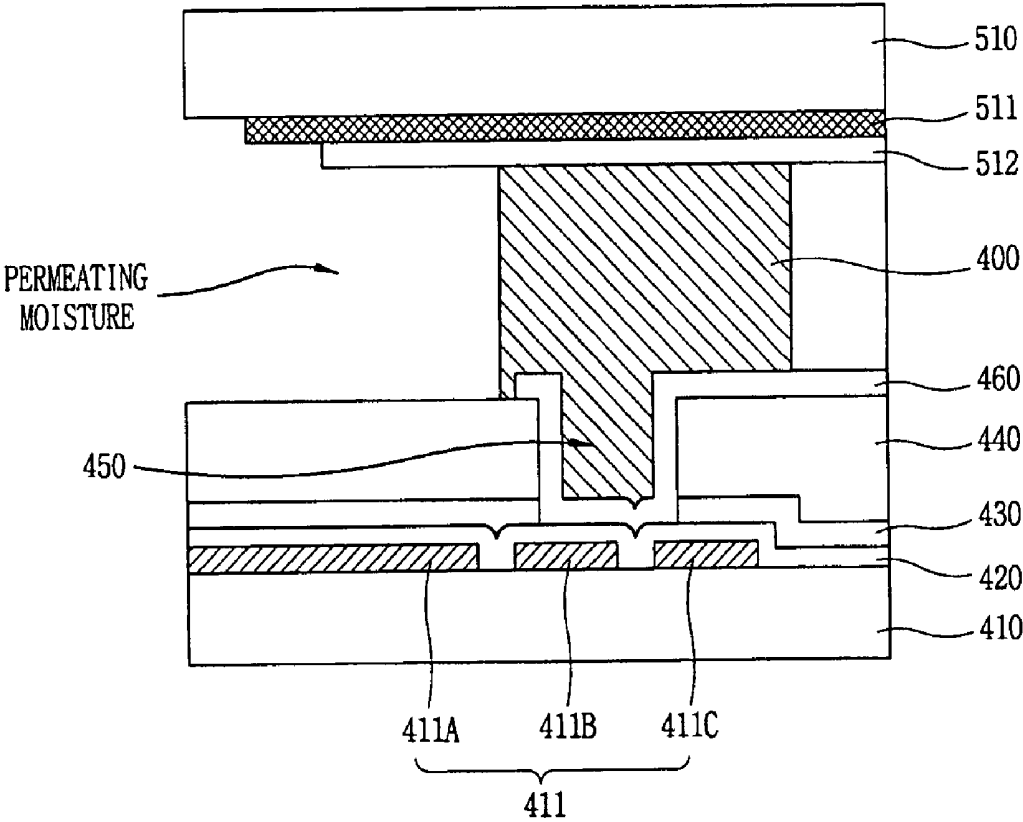

FIG. 6



LIQUID CRYSTAL DISPLAY PANEL AND FABRICATING METHOD THEREOF

[0001] This application claims the benefit of the Korean Application No. P2002-088460 filed on Dec. 31, 2002, which is hereby incorporated by reference.

BACKGROUND OF THE INVENTION

[0002] 1. Field of the Invention

[0003] The present invention relates to a liquid crystal display panel and a fabrication method thereof, and more particularly, to a liquid crystal display panel and a fabrication method thereof to prevent electrolytic corrosion between a pixel electrode formed on a thin film transistor array substrate and a conductive black matrix formed on a color filter substrate at a region where line-on-glass (LOG) type lines are formed on a liquid crystal display panel.

[0004] 2. Discussion of the Related Art

[0005] In general, a liquid crystal display device displays images by individually supplying data signals to liquid crystal cells arranged in a matrix configuration and controlling light transmittance of the liquid crystal cells. Accordingly, the liquid crystal display device includes a liquid crystal display panel on which liquid crystal cells are arranged in the matrix configuration and a driving circuit to drive the liquid crystal cells.

[0006] The liquid crystal display panel includes a color filter substrate and a thin film transistor array substrate attached to each other with a certain gap therebetween, and a liquid crystal material layer formed within the gap between the color filter substrate and the thin film transistor array substrate. On the thin film transistor array substrate of the liquid crystal display panel, a plurality of data lines for transmitting image information to the liquid crystal cells and a plurality of gate lines for transmitting scan signals to the liquid crystal cells intersect, and liquid crystal cells are defined at every intersection of the data lines and the gate lines.

[0007] A common electrode and a pixel electrode are formed facing inner surfaces of the color filter substrate and the thin film transistor array substrate to supply an electric field to the liquid crystal material layer. Here, the pixel electrode is formed at every liquid crystal cell of the thin film transistor array substrate while the common electrode is integrally formed at an entire surface of the color filter substrate. Accordingly, by controlling first voltages supplied to the pixel electrode when the common electrode receives a second voltage, light transmittance of the liquid crystal cells can be individually controlled. To control the voltages supplied to the pixel electrode of each liquid crystal cell, each liquid crystal cell includes a thin film transistor as a switching device.

[0008] The driving circuit includes a gate driving unit to supply a scan signal to the gate lines, a data driving unit to supply image information to the data lines, a timing controller to control a driving timing of the gate driving unit and the data driving unit, and a power supply unit to supply various driving voltages used for a liquid crystal display device. The timing controller controls a driving timing of the gate driving unit and the data driving unit through image

information and a control signal supplied from an external graphic processor, and supplies image information to the data driving unit.

[0009] The power supply unit generates driving voltages, such as a common voltage (Vcom), a gate high voltage (Vgh), a gate low voltage (Vgl) or a gamma reference voltage (Vref) used for the liquid crystal display device by using power supplied from the external graphic processor. The power supply unit also supplies them to the gate driving unit, the data driving unit, a gamma voltage generator, and the liquid crystal display panel.

[0010] The gate driving unit sequentially supplies a scan signal to the gate lines so that the liquid crystal cells arranged in the matrix configuration can be selected line-by-line, and image information is supplied to the liquid crystal cells of the selected one line from the data driving unit by way of the data lines.

[0011] When the image information is individually supplied to the pixel electrode of the liquid crystal cells and the common voltage (Vcom) is supplied to the common electrode, a voltage difference occurs between the pixel electrode and the common electrode, according to which an electric field is supplied to the liquid crystal material layer. Thus, the light transmittance of the liquid crystal cells are individually controlled to display a desired image.

[0012] The data driving unit and the gate driving unit, which are directly connected to the liquid crystal display panel, are fabricated with a plurality of integrated circuits (IC). The data driving integrated circuits and the gate driving integrated circuits are mounted on a tape carrier package (TCP) and are connected to the liquid crystal display panel in a tape automated bonding (TAB) method. When the data driving integrated circuits are connected to the liquid crystal display panel in the TAB method through the tape carrier package, the tape carrier package is connected to a data printed circuit board (PCB), image information, control signals, and driving voltages are supplied from the timing controller and the power supply unit through the lines mounted on the data printed circuit board. When the gate driving integrated circuits are connected to the liquid crystal display panel in the TAB method through the tape carrier package, the tape carrier package is connected to the gate printed circuit board, control signals and driving voltages are supplied from the timing controller and the power supply unit through the lines mounted on the gate printed circuit board.

[0013] Currently, as the semiconductor process techniques and packaging techniques advance, a highly integrated and high performance semiconductor chip is required. Accordingly, a controller, which has been mounted on the gate printed circuit board, can be mounted on the data printed circuit board, making one chip perform as a highly integrated, high performance semiconductor chip. As a result, the gate printed circuit board simply functions to transmit signals processed in the data printed circuit board.

[0014] FIG. 1 is a partial plan view of a liquid crystal display panel and a connection state of a driving unit according to the related art. In FIG. 1, the liquid crystal display panel includes a thin film transistor array substrate 10 and a color filter substrate 20 attached to face each other, a gate tape carrier package 30 connected to a gate pad

portion of the thin film transistor array substrate **10**, a data tape carrier package **40** connected to a data pad portion of the thin film transistor array substrate **10**, a gate printed circuit board **50** connected to the gate tape carrier package **30**, and a data printed circuit board **60** connected to the data tape carrier package **40**.

[0015] The data printed circuit board **60** includes a controller (not shown) to process image information, control signals, and driving voltages. The controller is highly integrated and has high performance to process control signals and driving voltages to be supplied to the gate printed circuit board **50**. Accordingly, the gate printed circuit board **50** has a simple function of transmitting the control signals and the driving voltages supplied from the data printed circuit board **60** to the gate pad portion of the thin film transistor array substrate **10** through the gate tape carrier package **30**.

[0016] To supply the control signals and the driving voltages from the data printed circuit board **60** to the gate printed circuit board **50**, connectors **55** and **65** are formed at the gate printed circuit board **50** and the data printed circuit board **60**. The connectors **55** and **65** formed at the gate printed circuit board **50** and the data printed circuit board **60** are electrically connected by a flexible plate cable (FPC) **70**.

[0017] However, the liquid crystal display device has the following disadvantages. First, since the connectors **55** and **65** are formed on the thin gate printed circuit board **50** and the thin data printed circuit board **60**, a thickness of the liquid crystal display device becomes as high as the thickness of the connectors **55** and **65**, thereby impeding obtaining of a thin liquid crystal display device. Second, to electrically connect the connectors **55** and **65**, the flexible plate cable **70** should be installed, which increases the number of processes for fabrication of a liquid crystal display device as well as its production cost. Thus, a liquid crystal display device of a line-on-glass method has been proposed in which lines to supply control signals and driving voltages from the data printed circuit board **60** to the gate printed circuit board **50** are mounted at an outer dummy region of the thin film transistor array substrate **10**.

[0018] FIG. 2 is a partial plan view of a liquid crystal display panel using a line-on-glass method and a connection state of a driving unit according to the related art. In FIG. 2, a liquid crystal display panel of a line-on-glass method includes a thin film transistor array substrate **110** and a color filter substrate **120** attached to face each other, a gate tape carrier package **130** connected to a gate pad portion of the thin film transistor array substrate **110**, a data tape carrier package **140** connected to a data pad portion of the thin film transistor array substrate **110**, a gate printed circuit board **150** connected to the gate tape carrier package **130**, and a data printed circuit board **160** connected to the data tape carrier package **140**.

[0019] The data printed circuit board **160** includes a controller to process image information, control signals, and driving voltages. The controller is highly integrated to process control signals and driving voltages to be supplied to the gate printed circuit board **150**. Accordingly, the gate printed circuit board **150** has a simple function of transmitting the control signals and the driving voltages supplied from the data printed circuit board **160** to the gate pad portion of the thin film transistor array substrate **110** through the gate tape carrier package **130**. In general, the liquid

crystal display panel is constructed such that the thin film transistor array substrate **110** and the color filter substrate **120** are attached with a certain gap therebetween in a facing manner, and a liquid crystal material layer is formed in the gap.

[0020] One shorter side and one longer side of the thin film transistor array substrate **110** protrude compared to the color filter substrate **120**, and a gate pad portion electrically connects to the gate lines of the thin film transistor array substrate **110** and a data pad portion electrically connects to the data lines of the thin film transistor array substrate **110** are formed at the protruded region.

[0021] The gate pad portion and the data pad portion are formed corresponding to an effective image display portion of the attached thin film transistor array substrate **110** and the color filter substrate **120**. Accordingly, the corner portion where one shorter side and one longer side of the thin film transistor array substrate **110** meet is a dummy region and provides no real purpose for the liquid crystal display panel. However, in the liquid crystal display panel of the line-on-glass method using the dummy region, line-on-glass lines **111** are mounted on the corner portion where one shorter side and one longer side of the thin film transistor array substrate **110** meet to supply control signals and driving voltages from the data printed circuit board **160** to the gate printed circuit board **150**. Thus, the connectors **55** and **65** of FIG. 1 do not need to be formed on the gate printed circuit board **150** and the data printed circuit board **160**, wherein the flexible plate cable **70** of FIG. 1 to electrically connect the connectors **55** and **65** is not required.

[0022] Driving voltages supplied to the gate printed circuit board **150** through the line-on-glass lines **111** include DC signals, such as a gate high voltage (V_{gh}), a gate low voltage (V_{gl}), a common voltage (V_{com}), a ground voltage (GND), and a power supply voltage (V_{cc}). Similarly, control signals supplied to the gate printed circuit board **150** through the line-on-glass lines **111** include AC signals, such as a gate start pulse (GSP), a gate shift clock (GSC), and a gate enable signal (GOE). Usually, the line-on-glass lines **111** are simultaneously patterned and formed during the process of forming gate lines and gate electrodes on the thin film transistor array substrate **110**.

[0023] FIG. 3 is a partial plan view of an enlarged region where line-on-glass lines are formed on the thin film transistor array substrate of FIG. 2 according to the related art. In FIG. 3, line-on-glass lines **111A**~**111C** are formed regularly spaced apart at the corner portion where one shorter side and one longer side of the thin film transistor array substrate **110** meet. The line-on-glass lines **111A**~**111C** are simultaneously patterned and formed during the process of forming the gate lines and the gate electrodes on the thin film transistor array substrate **110**. In addition, a seal pattern **112** is formed at the region of the thin film transistor array substrate **110** where the line-on-glass lines **111A**~**111C** are formed. The seal pattern **112** is formed along an outer edge of an image display region of the liquid crystal display panel to attach the thin film transistor array substrate **110** and a color filter substrate (i.e., **120** in FIG. 2).

[0024] FIG. 4 is a cross sectional view along I-I' of FIG. 3 according to the related art. The liquid crystal display panel of the line-on-glass method and its fabrication method will now be described in detail with reference to FIG. 4.

[0025] First, line-on-glass lines **211** are patterned regularly spaced apart at an upper surface of a thin film transistor array substrate **210**, wherein the line-on-glass lines **211** are simultaneously patterned and formed during the process of forming gate lines and gate electrodes on the thin film transistor array substrate **210**. A gate insulation film **220** and an active layer **230** are sequentially formed at the upper surface of the thin film transistor array substrate **210** with the line-on-glass lines **211** patterned regularly spaced apart thereon. The gate insulation film **220** and the active layer **230** are sequentially formed to form a thin film transistor at an image display portion of the thin film transistor array substrate **210**, and though not shown on the drawing, on the image display portion, the active layer **230** is patterned and then data lines and source/drain electrodes of the thin film transistor are simultaneously patterned.

[0026] At a portion of the active layer **230** where the thin film transistor of the image display portion is formed, a semiconductor layer made of amorphous silicon and an ohmic contact layer made of n+ amorphous silicon doped with phosphorus (P) at a high concentration are consecutively deposited and patterned. Then, when the data lines and the source/drain electrodes are patterned, the exposed ohmic contact layer is removed to work as a channel of the thin film transistor. Accordingly, the ohmic contact layer is removed at the region other than the lower portions of the data lines and the source/drain electrodes, thereby leaving only the semiconductor layer.

[0027] A passivation film **240** is formed at an upper surface of the active layer **230**, and is made of an inorganic material as a thin film, such as SiNx or SiOx. However, to improve an aperture ratio of the liquid crystal display device, an organic material, such as benzocyclobutene (BCB), a spin-on-glass (SOG) or photo-acryl, is applied as a thick film.

[0028] The passivation film **240** is selectively etched to form a drain contact hole exposing a portion of the drain electrode, and the exposed drain electrode electrically contacts a pixel electrode provided in a unit pixel through the drain contact hole. Since the organic material, such as benzocyclobutene (BCB), a spin-on-glass (SOG) or photo-acryl, is used for the passivation film **240**, a dry etching is performed to form the drain contact hole.

[0029] The passivation film **240** is made of an organic material and does not have good bonding characteristics as a thick film with respect to a seal pattern which will be formed in a follow-up process. Moreover, the attached thin film transistor array substrate **210** and the color filter substrate **310** may crack or moisture may permeate into the image display portion, thereby causing defects in the liquid crystal display panel. Thus, to improve the adhesive force with respect to a seal pattern **270**, when the drain contact hole is formed, the passivation film **240** at the region where the line-on-glass lines **211** are formed is simultaneously dry-etched to form a plurality of bonding holes **250**. Accordingly, the active layer **230** formed at the lower side of the passivation film **240** is also etched as being affected by the dry-etching of the passivation film **240**, thereby exposing the gate insulation film **220** at the bottom surface of the bonding holes **250**.

[0030] A pixel electrode **260** overlapping with the line-on-glass lines **211** is patterned at an upper portion of a

resulting structure where the gate insulation film **220**, the passivation film **240** and the bonding holes **250** have been formed. The pixel electrode **260** is provided in the unit pixel at the region where the thin film transistor of the image display portion is formed, and patterned by wet-etching to electrically contact the drain electrode through the drain contact hole formed at the passivation film **240** and patterned to overlap with the line-on-glass lines **211** at the region where the line-on-glass lines **211** are formed.

[0031] The reason of patterning the pixel electrode **260** to overlap with the line-on-glass lines **211** is as follows. If the dry-etching is excessively performed in forming the bonding holes **250** at the passivation film **240**, the gate insulation film **220** exposed at the bottom surface of the bonding holes **250** would be also etched by being affected by the dry-etching of the passivation film **240**, and accordingly, the line-on-glass lines **211** formed at the lower side of the gate insulation film **220** at the bottom surface of the bonding holes **250** would be exposed. In this state, if the pixel electrode **260** is removed through wet-etching at the region where the line-on-glass lines **211** have been formed, the line-on-glass lines **211** exposed through the bonding holes **250** would be also etched during the wet-etching of the pixel electrode **260**. When the line-on-glass lines **211** are partially etched and damaged, characteristics of electrical signals transmitted through the line-on-glass lines **211** would be changed, and in a worst case, the line-on-glass lines **211** are open, thereby causing a driving deficiency or a degradation of a picture quality of a liquid crystal display device.

[0032] Therefore, to prevent such problems, the pixel electrode **260** is widely patterned overlapping with the line-on-glass lines **211**. As stated above, when the pixel electrode **260** is widely patterned overlapping with the line-on-glass lines **211**, the pixel electrode **260** and the line-on-glass line **211** may electrically contact. That is, if a dry-etching to form the bonding holes **250** at the passivation film **240** is performed excessively, the gate insulation film **220** exposed at the bottom surface of the bonding holes **250** is also etched due to influence of the dry-etching on the passivation film **240**, thereby resulting in the line-on-glass line **211** being exposed at the bottom surface of the bonding holes **250** and electrically contacting the pixel electrode **260**.

[0033] Meanwhile, a black matrix **311** is coated at an upper surface of the color filter substrate **310**, on which red (R), green (G) and blue (B) color filters (not shown) are formed corresponding to the unit pixel of the image display portion, and a common electrode **312** is formed at the entire upper surface of the color filter substrate **310** including the black matrix **311** and the color filter. At this time, the black matrix **311** is formed at regions corresponding to gate lines, data lines and thin film transistors formed at the image display portion of the thin film transistor array substrate **210** to prevent a phenomenon that red, green and blue lights transmitted by unit pixels through the color filters are mixed with adjacent pixels to degrade of picture quality of the liquid crystal display panel.

[0034] As the black matrix **311**, a black resin or a Cr material may be applied. The Cr material is more advantageous in the aspect of making a thin film and a material cost compared to the black resin, and in addition, because the Cr material can be precisely patterned at a desired position, it is generally used.

[0035] The thin film transistor array substrate **210** and the color filter substrate **310** are attached by the seal pattern **270** so that the pixel electrode **260** and the common electrode **312** face each other. At this time, the black matrix **311** and the common electrode **312** formed on the color filter substrate **310** are extended to a predetermined distance outwardly of the seal pattern **270**, and the black matrix **311** is more extended than the common electrode **312**. Accordingly, at the region where the line-on-glass lines **211** (including **211A**, **211B** and **211C**) are formed, the pixel electrode **260** faces the black matrix **311** and the common electrode **312** extended outwardly of the seal pattern **270**.

[0036] The seal pattern **270** covers the image display portion to prevent infiltration of moisture or a contaminant from outside. Meanwhile, the outer edge of the seal pattern **270**, that is, the region where the line-on-glass lines **211** of the liquid crystal display panel are formed is not prevented from infiltration of moisture or a contaminant. If moisture or contamination infiltrates into the region where the line-on-glass lines **211** are formed, electrolytic corrosion occurs between the facing pixel electrode **260** and the black matrix **311** made of Cr.

[0037] In other words, when the pixel electrode **260** is widely patterned overlapping with the line-on-glass lines **211**, the pixel electrode **260** and the line-on-glass lines **211** contact electrically each other so that a gate low voltage (Vgl) of $-5V$ transmitted through the line-on-glass lines **211** is applied to the pixel electrode **260**. Meanwhile, the common electrode **312** to which a common voltage of $3V$ is applied contacts the black matrix **311** made of Cr, so the common voltage of $3V$ is applied to the black matrix **311**.

[0038] Thus, if moisture or contamination infiltrates between the pixel electrode **260**, to which $-5V$ has been applied, and the black matrix **311**, to which $3V$ has been applied, electrolyte corrosion occurs. Then, the Cr component of the black matrix **311** is ionized because of the electrolyte corrosion, and as the electrolyte of the black matrix **311** passes through the seal pattern **270** and proceeds to the image display portion, light is leaked from the image display portion of the liquid crystal display panel. In addition, because the Cr component of the black matrix **311** is ionized to cause a current flow, a short can occur between the line-on-glass lines **211** and the black matrix **311**. Also, because the black matrix **311** is in contact electrically with the common electrode **312**, an electric signal transmitted through the line-on-glass lines **211** and the common voltage applied to the common electrode **312** are affected by the short, thereby causing a deficiency in driving the liquid crystal display panel.

SUMMARY OF THE INVENTION

[0039] Accordingly, the present invention is directed to a liquid crystal display panel and a fabrication method thereof that substantially obviates one or more of the problems due to limitations and disadvantages of the related art.

[0040] An object of the present invention is to provide a liquid crystal display panel and a fabrication method thereof in which an electrolytic corrosion occurring between a pixel electrode formed on a thin film transistor array substrate and a conductive black matrix formed on a color filter substrate can be prevented at a region where line-on-glass (LOG) type lines are formed on a liquid crystal display panel.

[0041] Additional features and advantages of the invention will be set forth in the description which follows, and in part will be apparent from the description, or may be learned by practice of the invention. The objectives and other advantages of the invention will be realized and attained by the structure particularly pointed out in the written description and claims hereof as well as the appended drawings.

[0042] To achieve these and other advantages and in accordance with the purpose of the present invention, as embodied and broadly described herein, a liquid crystal display panel comprises a first substrate having an image display portion thereon; a second substrate; and a seal pattern disposed along an outer periphery of the image display portion to attach the first substrate with the second substrate, wherein the first substrate includes at least one conductive line disposed at a corner portion of the first substrate, a multi-layer film disposed on the first substrate and the at least one conductive line, the multi-layer film defining a plurality of bonding holes disposed along a region where the seal pattern is disposed, and a transparent electrode formed on the multi-layer film and in the bonding holes such that the transparent electrode is entirely disposed within a boundary defined by an outer side of the seal pattern.

[0043] In another aspect, a method for fabricating liquid crystal display panel comprises the steps of preparing a first substrate as a thin film transistor substrate; preparing a second substrate as a color filter substrate; forming at least one transparent electrode on at least one of the first substrate and the second substrate; and forming a seal pattern to attach the first substrate with the second substrate, wherein the transparent electrode is entirely disposed within a boundary defined by an outer side of the seal pattern.

[0044] In another aspect, a liquid crystal display panel comprises a first substrate; a second substrate; a seal pattern disposed along an outer edge of an image display portion of the first substrate and the second substrate, and attaching the first and second substrates; at least one line-on-glass line disposed at a corner portion of the first substrate; a multi-layer film disposed on the first substrate with the line-on-glass line formed thereon and having a plurality of bonding holes disposed regularly along the region where the seal pattern passes; and a transparent electrode disposed on the multi-layer film having a plurality of the bonding holes overlapping the line-on-glass line and patterned not to be protruded from the seal pattern.

[0045] In another aspect, a liquid crystal display panel comprises a first substrate having an image display portion thereon; a second substrate; and a seal pattern disposed along an outer periphery of the image display portion to attach the first substrate with the second substrate, wherein at least one of the first substrate and the second substrate includes a transparent electrode such that the transparent electrode is entirely disposed within a boundary defined by an outer side of the seal pattern.

[0046] It is to be understood that both the foregoing general description and the following detailed description are exemplary and explanatory and are intended to provide further explanation of the invention as claimed.

BRIEF DESCRIPTION OF THE DRAWINGS

[0047] The accompanying drawings, which are included to provide a further understanding of the invention and are incorporated in and constitute a part of this specification, illustrate embodiments of the invention and together with the description serve to explain the principles of the invention. In the drawings:

[0048] FIG. 1 shows a liquid crystal display panel and a connection state of a related driving unit;

[0049] FIG. 2 shows the liquid crystal display panel of the line-on-glass method and a connection state of a related driving unit;

[0050] FIG. 3 is an enlarged view showing a region shown in FIG. 2 where the line-on-glass lines are formed.

[0051] FIG. 4 is an exemplary view showing a section taken along line I-I' of FIG. 3.

[0052] FIG. 5 is an exemplary view showing a liquid crystal display panel and its partial enlarged plane structure in accordance with an embodiment of the present invention; and

[0053] FIG. 6 is an exemplary view showing a section taken along line II-II' of FIG. 5.

DETAILED DESCRIPTION OF THE PREFERRED EMBODIMENTS

[0054] Reference will now be made in detail to the preferred embodiments of the present invention, examples of which are illustrated in the accompanying drawings.

[0055] FIG. 5 is partial plan view of an exemplary liquid crystal display panel according to the present invention. In FIG. 5, a first substrate 310 and a second substrate 320 may be attached together such that one shorter side and one longer side of the first substrate 310 may protrude, and an image display portion 330, upon which a plurality of pixels may be arranged in a matrix configuration, may be formed within the region where the first substrate 310 and the second substrate 320 are attached together. For example, the first substrate 310 may be a thin film transistor (TFT) array substrate of the liquid crystal display panel, and the second substrate 320 may be a color filter (CF) substrate.

[0056] Accordingly, on the image display portion 330 of the first substrate 310, a plurality of gate lines may be arranged along a horizontal direction at regular intervals, a plurality of data lines may be arranged along a vertical direction at regular intervals, and a plurality of pixels may be defined at every intersection of the gate lines and the data lines in a matrix configuration. In addition, each pixel may have a TFT as a switching device and a pixel electrode connected to the TFT. The thin film transistor may include a gate electrode that may be simultaneously patterned with the gate lines to be electrically connected to the gate lines, a source electrode that may be simultaneously patterned with the data lines to be electrically connected to the data lines, and a drain electrode that may be simultaneously patterned with the data lines and the source electrode to be electrically connected to the pixel electrode.

[0057] On the image display portion 330 of the second substrate 320, there are provided red, green, and blue color filters coated separately in each pixel defined by a black

matrix, and a common electrode, which is a counter electrode of the pixel electrode, formed on the first substrate 310. The first substrate 310 and the second substrate 320 may be attached together by a seal pattern 300 formed along an outer edge of the image display portion 330. Accordingly, randomly scattered spacer balls may be provided or patterned spacers may be formed through photolithographic processes on the first substrate 310 or on the second substrate 320, thereby providing a certain space between the first substrate 310 and the second substrate 320 wherein a liquid crystal material layer is formed with the space.

[0058] At the protruded shorter side of the first substrate 310, a gate pad portion 340 may be formed at a region corresponding to the image display portion 330, and may be electrically connected to the gate lines for supplying driving signals to the gate lines. At the protruded longer side of the first substrate 310, a data pad portion 350 may be formed at a region corresponding to the image display portion 330, and may be electrically connected to the data lines for supplying image information to the data lines.

[0059] At the corner portion where the protruded shorter side and longer side of the first substrate 310 meet, line-on-glass lines 311A~311C may be mounted to transmit DC signals, such as a gate high voltage (V_{gh}), a gate low voltage (V_{gl}), a common voltage (V_{com}), a ground voltage (GND) and a power supply voltage (V_{cc}), as well as AC signals, such as a gate start pulse (GSP), a gate shift clock (GSC), and a gate enable signal (GOE). The line-on-glass lines 311A~311C may be simultaneously patterned and formed while forming the gate lines and the gate electrodes on the first substrate 310.

[0060] A pixel electrode (not shown) may be patterned with at least a multi-layer intermediate film (not shown) interposed therebetween to overlap with the line-on-glass lines 311A~311C. Also, the pixel electrode may be patterned to not be protruded from the seal pattern 300.

[0061] FIG. 6 is a cross sectional view along II-II' of FIG. 5 according to the present invention. The liquid crystal display panel of the line-on-glass method and its fabrication method in accordance with the present invention will now be described. First, line-on-glass lines 411(411A, 411B, and 411C) may be patterned at regular intervals on the first substrate 410 wherein the line-on-glass lines 411 may be simultaneously patterned during the process of forming the gate lines and the gate electrodes at the image display portion of the first substrate 410.

[0062] Next, a gate insulation film 420 and an active layer 430 may be sequentially formed at an upper surface of the first substrate 410 with the line-on-glass lines 411 patterned at regular intervals thereon. The gate insulation film 420 and the active layer 430 may be sequentially formed to form a thin film transistor at the image display portion of the first substrate 410, and although not shown, on the image display portion, after the active layer 430 has been patterned, the data lines and the source/drain electrodes may be simultaneously patterned.

[0063] At a region of the active layer 430 where the thin film transistor of the image display portion is formed, a semiconductor layer made of amorphous silicon and an ohmic contact layer made of n+amorphous silicon doped with phosphorus (P) at high concentration may be succes-

sively deposited and patterned. When the data lines and source/drain electrodes are patterned, the exposed ohmic contact layer may be removed to define a channel of the thin film transistor. Accordingly, as the ohmic contact layer is removed at the region other than the lower portions of the data lines and source/drain electrodes, only the semiconductor layer remains.

[0064] Then, a passivation film 440 may be formed on the active layer 430, wherein the passivation film 440 may include an organic material, such as benzocyclobutene (BCB), a spin-on-glass (SOG), or a photo-acryl with a low dielectric constant, by which an aperture ratio of the liquid crystal display device may be improved. The passivation film 440 may be selectively etched to form a drain contact hole exposing a portion of the drain electrode, and the drain electrode may electrically contact the pixel electrode provided at the unit pixel through the drain contact hole. Since the organic material, such as benzocyclobutene (BCB), a spin-on-glass (SOG), or a photo-acryl with a low dielectric constant, may be applied to form the passivation film 440, a dry-etching may be performed to form the drain contact hole.

[0065] The passivation film 440 having an organic material formed as a thick film may not have good bonding characteristics with respect to the seal pattern 400 to be formed in a follow-up process. Thus, the attached first substrate 410 and the second substrate 510 may crack or moisture may permeate into the image display portion, thereby causing defects in the liquid crystal display panel. To improve the adhesive force with respect to the seal pattern 400, when the drain contact hole is formed, the passivation film 440 at the region where the line-on-glass lines 411 are formed may be simultaneously dry-etched to form a bonding hole 450. Accordingly, the active layer 430 formed at the lower side of the passivation film 440 may also be etched as being affected by the dry-etching of the passivation film 440 so that the gate insulation film 420 is exposed at the bottom surface of the bonding hole 450.

[0066] The pixel electrode 460 is patterned at an upper portion of a resulting structure that the gate insulation film 420, the passivation film 440 and the bonding hole 450 have been formed to overlap with the line-on-glass lines 411. At this time, the pixel electrode 460 is patterned not to be protruded from the seal pattern 400. As stated above, the pixel electrode 460 is provided in the unit pixel at the region where the thin film transistor of the image display portion is formed and patterned by wet-etching to electrically contact the drain electrode through the drain contact hole formed at the passivation film 440. Further, at this time, the pixel electrode 460 is patterned to overlap with the line-on-glass lines 411 and to not be protruded from the seal pattern 400.

[0067] The reason of patterning the pixel electrode 460 to overlap with the line-on-glass lines 411 is as follows. If the dry-etching is excessively performed in forming the bonding hole 450 at the passivation film 440, the gate insulation film 420 exposed at the bottom surface of the bonding hole 450 would be also etched by the dry-etching of the passivation film 440. Accordingly, the line-on-glass lines 411 formed at the lower side of the gate insulation film 420 at the bottom surface of the bonding hole 450 would be exposed. If the pixel electrode 460 is removed through a wet-etching at the region where the line-on-glass lines 411 have been formed,

the line-on-glass lines 411 exposed through the bonding hole 450 would be also etched by the wet-etching of the pixel electrodes 460.

[0068] When the line-on-glass lines 411 are partially etched and damaged, characteristics of electric signals transmitted through the line-on-glass lines 411 would be changed, and in a worst case, the line-on-glass lines 411 are open, thereby causing a driving deficiency or a degradation of a picture quality of a liquid crystal display device. Therefore, to prevent such problems, the pixel electrode 460 is patterned overlapping with the line-on-glass lines 411.

[0069] Meanwhile, a black matrix 511 is coated along an outer edge of pixels of the image display portion at an upper surface of the second substrate 510, on which red (R), green (G) and blue (B) color filters (not shown) are formed corresponding to the unit pixel of the image display part. A common electrode 512 is formed at the upper surface of the color filter substrate 510 including the black matrix 511 and the color filter.

[0070] At this time, the black matrix 511 is formed at regions corresponding to gate lines, data lines and thin film transistors formed at the image display portion of the thin film transistor array substrate 510 to prevent a phenomenon that red, green and blue lights transmitted by unit pixels through the color filters are mixed with adjacent pixels to degrade the picture quality of the liquid crystal display panel. As the black matrix 511, a resin or a Cr material may be applied. The Cr material is more advantageous than the resin in that a thin film is formed, a material cost is cheap, and a pattern is precisely formed at a desired position.

[0071] The first substrate 410 and the second substrate 510 are attached by the seal pattern 400 so that the pixel electrode 460 and the common electrode 512 face each other. At this time, the black matrix 511 and the common electrode 512 formed on the second substrate 510 are extended to a predetermined distance outwardly of the seal pattern 400, and the black matrix 511 is more extended than the common electrode 512.

[0072] Comparatively, referring back to the related art of FIG. 4, the thin film transistor array substrate 210 of the region where the line-on-glass lines 211 are formed, the pixel electrode 260 is extended outwardly of the seal pattern 270 overlapping with the line-on-glass lines 211 so that it faces the black matrix 311 and the common electrode 312 which are extended outwardly of the seal pattern 270. If the passivation film 240 is excessively etched, the pixel electrode 260 electrically contacts the line-on-glass lines 211 in the bonding holes 250, and also, the common electrode 312 and the black matrix 311 made of Cr contact electrically each other. Then, because an electrical signal transmitted through the line-on-glass lines 211 is applied to the pixel electrode 260 and a common voltage applied to the common electrode 312 is applied to the black matrix 311, if moisture or contamination infiltrates between the pixel electrode 260 and the black matrix 311, electrolytic corrosion occurs there.

[0073] However, in the present invention, as described above, though the pixel electrode 460 is patterned to overlap with the line-on-glass lines 411 but not to protrude from the seal pattern 400 (that is, it is patterned within the seal pattern 400). The seal pattern 400 prevents infiltration of moisture or a contaminant from outside. Thus, even though the first

substrate **410** and the second substrate **510** are attached by the seal pattern **400** so that the pixel electrode **460** of the first substrate **410** and the common electrode **512** of the second substrate **510** face each other. Because the pixel electrode **460** is not formed at the outer side of the seal pattern **400**, the electrolytic corrosion as in the related art does not occur.

[0074] Meanwhile, unlike the case shown in **FIG. 6**, if the common electrode **512** formed on the second substrate **510** is patterned not to be protruded from the seal pattern **400**, electrolytic corrosion can be also prevented. In addition, if both the pixel electrode **460** and the common electrode **512** are patterned not to be protruded from the seal pattern **400**, the electrolytic corrosion can be also prevented.

[0075] As so far described, the liquid crystal display panel and its fabrication method of the present invention have the following advantages. That is, the pixel electrode is formed overlapping with the line-on-glass lines mounted at the corner portion of the thin film transistor array substrate but not protruded from the seal pattern which attaches the thin film transistor array substrate and the color filter substrate. Accordingly, such an electrolytic corrosion as in the related art, in which moisture or contamination infiltrates between the pixel electrode formed extended outwardly of the seal pattern on the thin film transistor array substrate and the black matrix extended outwardly of the seal pattern on the color filter substrate, can be prevented. In addition, because the electrolytic corrosion between the pixel electrode and the black matrix is prevented, light leakage caused at the image display portion of the liquid crystal display panel as the electrolytic corrosion of the black matrix proceeds to the image display portion can be accordingly prevented, thereby enhancing a picture quality. Moreover, because ionization of the Cr component of the black matrix caused due to the electrolytic corrosion which occurs a current flow is prevented, shorting between the pixel electrode of the thin film transistor array substrate and the black matrix of the color filter substrate is prevented at the region where the line-on-glass lines are formed, according to which short between the line-on-glass lines being in contact electrically with the pixel electrode and the common electrode being in electrical contact with the black matrix can be also prevented. Therefore, a deficiency of driving of the liquid crystal display panel can be prevented.

[0076] It will be apparent to those skilled in the art that various modifications and variations can be made in the liquid crystal display panel and fabricating method thereof of the present invention without departing from the spirit or scope of the invention. Thus, it is intended that the present invention cover the modifications and variations of this invention provided they come within the scope of the appended claims and their equivalents.

What is claimed is:

1. A liquid crystal display panel, comprising:

a first substrate having an image display portion thereon;
a second substrate; and

a seal pattern disposed along an outer periphery of the image display portion to attach the first substrate with the second substrate,

wherein the first substrate includes:

at least one conductive line disposed at a corner portion of the first substrate,

a multi-layer film disposed on the first substrate and the at least one conductive line, the multi-layer film defining a plurality of bonding holes disposed along a region where the seal pattern is disposed, and

a transparent electrode formed on the multi-layer film and in the bonding holes such that the transparent electrode is entirely disposed within a boundary defined by an outer side of the seal pattern.

2. The liquid crystal display panel according to claim 1, wherein the first substrate and the second substrate are attached such that one shorter side and one longer side of the first substrate protrude from a boundary defined by the second substrate.

3. The liquid crystal display panel according to claim 2, wherein a gate pad portion is disposed at the protruded shorter side of the first substrate and a data pad portion is disposed at the protruded longer side of the first substrate.

4. The liquid crystal display panel according to claim 2, wherein the at least one conductive line includes at least one line-on-glass line disposed at a corner portion of the first substrate where the shorter side and the longer side meet.

5. The liquid crystal display panel according to claim 1, wherein the at least one conductive line transmits DC signals including a gate high voltage (V_{gh}), a gate low voltage (V_{gl}), a common voltage (V_{com}), a ground voltage (GND) and a power supply voltage (V_{cc}), and AC signals including a gate start pulse (GSP), a gate shift clock (GSC) and a gate enable signal (GOE).

6. The liquid crystal display panel according to claim 1, wherein the multi-layer film includes a gate insulation film, a semiconductor layer, and a passivation film.

7. The liquid crystal display panel according to claim 6, wherein the passivation film includes at least one of a benzocyclobutene (BCB), a spin-on-glass (SOG), and a photo-acryl.

8. The liquid crystal display panel according to claim 1, wherein the second substrate includes:

a black matrix defining outer edges of pixels of the image display portion;

a color filter disposed corresponding to the unit pixel of the image display portion; and

a common electrode disposed at the upper surface of the second substrate having the black matrix and the color filter.

9. The liquid crystal display panel according to claim 8, wherein the common electrode is disposed within the image display portion and covered by the seal pattern.

10. The liquid crystal display panel according to claim 1, wherein the bonding holes are disposed over the at least one conductive line.

11. A method for fabricating liquid crystal display panel, comprising the steps of:

preparing a first substrate as a thin film transistor substrate;

preparing a second substrate as a color filter substrate;

forming at least one transparent electrode on at least one of the first substrate and the second substrate; and

forming a seal pattern to attach the first substrate with the second substrate,

wherein the transparent electrode is entirely disposed within a boundary defined by an outer side of the seal pattern.

12. The method according to claim 11, wherein the first substrate and the second substrate are attached such that one shorter side and one longer side of the first substrate protrude from a boundary defined by the second substrate.

13. The method according to claim 12, wherein a gate pad portion is disposed at the protruded shorter side of the first substrate and a data pad portion is disposed at the protruded longer side of the first substrate.

14. The method according to claim 12, wherein the at least one conductive line includes at least one line-on-glass line disposed at a corner portion of the first substrate where the shorter side and the longer side meet.

15. The method according to claim 11, wherein the at least one conductive line transmits DC signals including a gate high voltage (V_{gh}), a gate low voltage (V_{gl}), a common voltage (V_{com}), a ground voltage (GND) and a power supply voltage (V_{cc}), and AC signals including a gate start pulse (GSP), a gate shift clock (GSC) and a gate enable signal (GOE).

16. The method according to claim 11, further comprising the step of forming a multi-layer film on the first substrate and the at least one conductive line, the multi-layer film defining a plurality of bonding holes.

17. The method according to claim 16, wherein the multi-layer film includes a gate insulation film, a semiconductor layer, and a passivation film.

18. The method according to claim 17, wherein the passivation film includes at least one of a benzocyclobutene (BCB), a spin-on-glass (SOG), and a photo-acryl.

19. The method according to claim 11, wherein the second substrate includes:

a black matrix defining outer edges of pixels of an image display portion;

a color filter disposed corresponding to the unit pixel of the image display portion; and

a common electrode disposed at a surface of the second substrate having the black matrix and the color filter.

20. The method according to claim 19, wherein the common electrode is disposed within the image display portion and covered by the seal pattern.

21. A liquid crystal display panel, comprising:

a first substrate;

a second substrate;

a seal pattern disposed along an outer edge of an image display portion of the first substrate and the second substrate, and attaching the first and second substrates;

at least one line-on-glass line disposed at a corner portion of the first substrate;

a multi-layer film disposed on the first substrate with the line-on-glass line formed thereon and having a plurality of bonding holes disposed regularly along the region where the seal pattern passes; and

a transparent electrode disposed on the multi-layer film having a plurality of the bonding holes overlapping the at least one line-on-glass line and patterned not to be protruded from the seal pattern.

22. A liquid crystal display panel, comprising:

a first substrate having an image display portion thereon;

a second substrate; and

a seal pattern disposed along an outer periphery of the image display portion to attach the first substrate with the second substrate,

wherein at least one of the first substrate and the second substrate includes a transparent electrode such that the transparent electrode is entirely disposed within a boundary defined by an outer side of the seal pattern.

23. The liquid crystal display panel according to claim 22, wherein the transparent electrode defines a pixel electrode.

24. The liquid crystal display panel according to claim 22, wherein the transparent electrode defines a common electrode.

* * * * *

专利名称(译)	液晶显示面板及其制造方法		
公开(公告)号	US20040125315A1	公开(公告)日	2004-07-01
申请号	US10/669014	申请日	2003-09-24
[标]申请(专利权)人(译)	乐金显示有限公司		
申请(专利权)人(译)	LG.PHILIPS LCD CO. , LTD.		
当前申请(专利权)人(译)	LG DISPLAY CO. , LTD.		
[标]发明人	PARK DAE LIM HWANG SEONG SOO KIM YOUNG SIK MOON SU HWAN		
发明人	PARK, DAE-LIM HWANG, SEONG-SOO KIM, YOUNG-SIK MOON, SU-HWAN		
IPC分类号	G02F1/1345 G02F1/13 G02F1/1339		
CPC分类号	G02F1/1339 G02F2201/50 G02F1/136286 G02F1/13452		
优先权	1020020088460 2002-12-31 KR		
其他公开文献	US6982779		
外部链接	Espacenet USPTO		

摘要(译)

液晶显示面板包括第一基板，第二基板和密封图案。第一基板上具有图像显示部分，并且密封图案沿着图像显示部分的外周边，以将第一基板与第二基板连接。第一基板包括设置在第一基板的角部的至少一条导线，设置在第一基板和至少一条导线上的多层膜，以及形成在多层膜上的透明电极粘接孔。多层膜限定沿着设置密封图案的区域设置的多个接合孔。这里，透明电极完全设置在由密封图案的外侧限定的边界内。

