



(19) **United States**

(12) **Patent Application Publication**
Shin

(10) **Pub. No.: US 2002/0024490 A1**

(43) **Pub. Date: Feb. 28, 2002**

(54) **DRIVING CIRCUIT WITH LOW OPERATIONAL FREQUENCY FOR LIQUID CRYSTAL DISPLAY**

(30) **Foreign Application Priority Data**

May 16, 1997 (KR)..... P97-19027

(76) **Inventor: Min Cheol Shin, Kyungsook-do (KR)**

Publication Classification

Correspondence Address:
LONG ALDRIDGE & NORMAN, LLP
Sixth Floor, Suite 600
701 Pennsylvania Avenue, N.W.
Washington, DC 20004 (US)

(51) **Int. Cl.⁷ G09G 3/36**

(52) **U.S. Cl. 345/87**

(57) **ABSTRACT**

A driving circuit for driving a liquid crystal display is provided. The driving circuit includes a clock generator processing a first clock signal to output a second clock signal, the clock speed of the second clock signal being half of that of the first clock signal, a memory for storing a first video data and a second video data in accordance with the first clock signal, and a data controller for simultaneously outputting the first video data and the second video data stored in the memory in accordance with the second clock signal.

(21) **Appl. No.: 09/982,872**

(22) **Filed: Oct. 22, 2001**

Related U.S. Application Data

(63) **Continuation of application No. 09/006,592, filed on Jan. 13, 1998.**

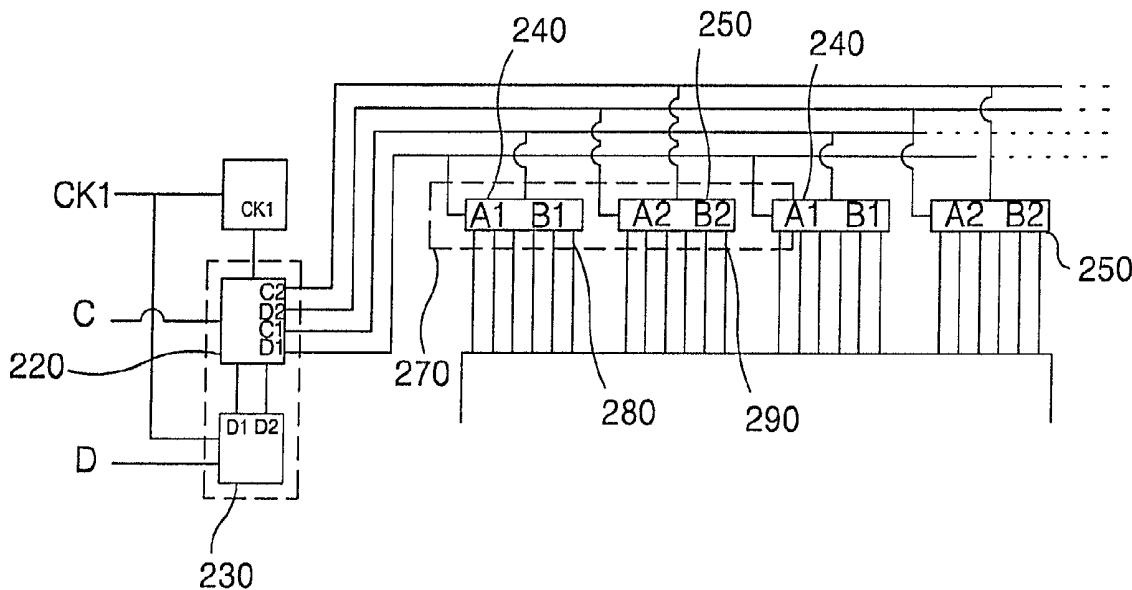

FIG. 1

CONVENTIONAL ART

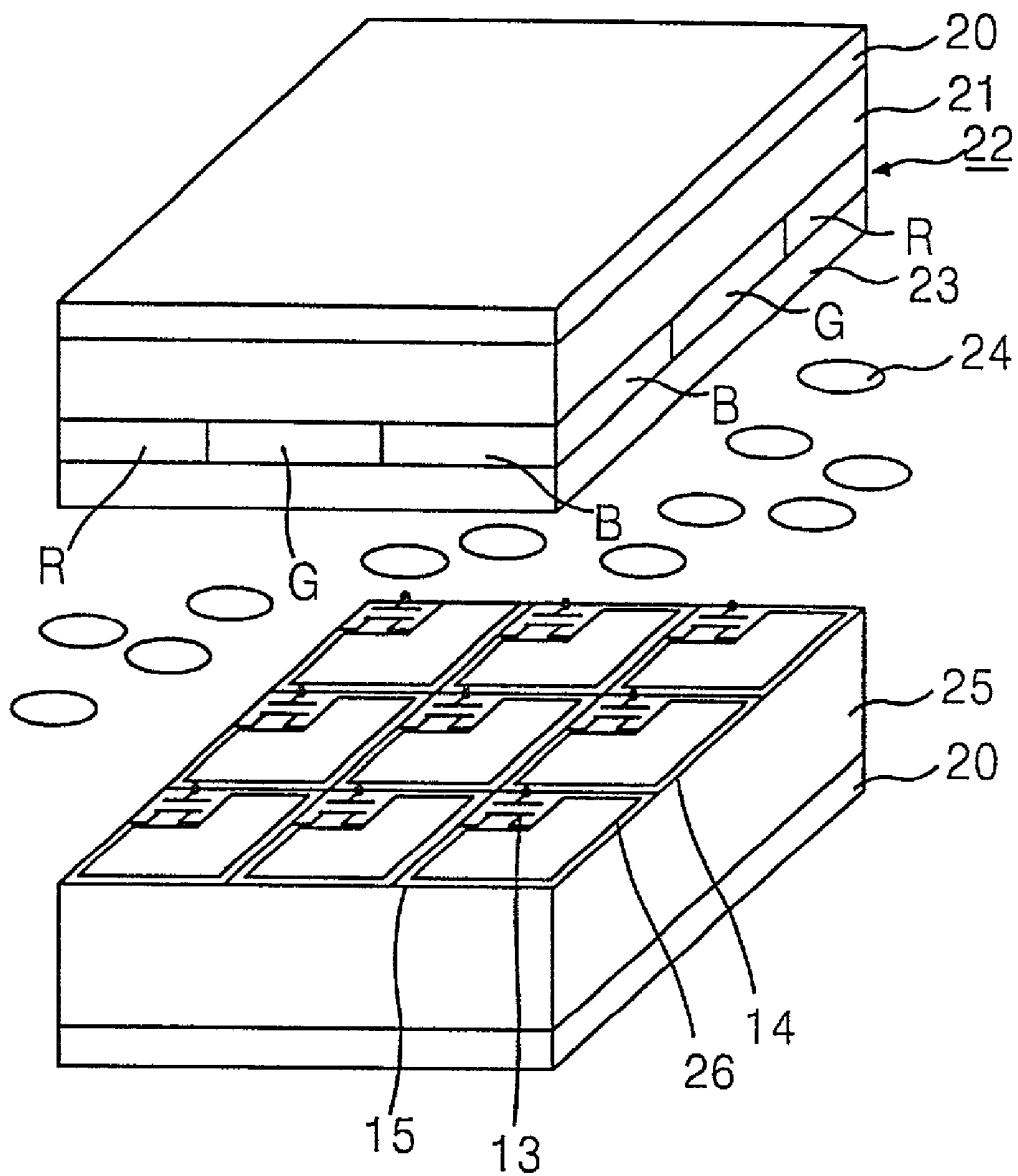

FIG. 2

CONVENTIONAL ART

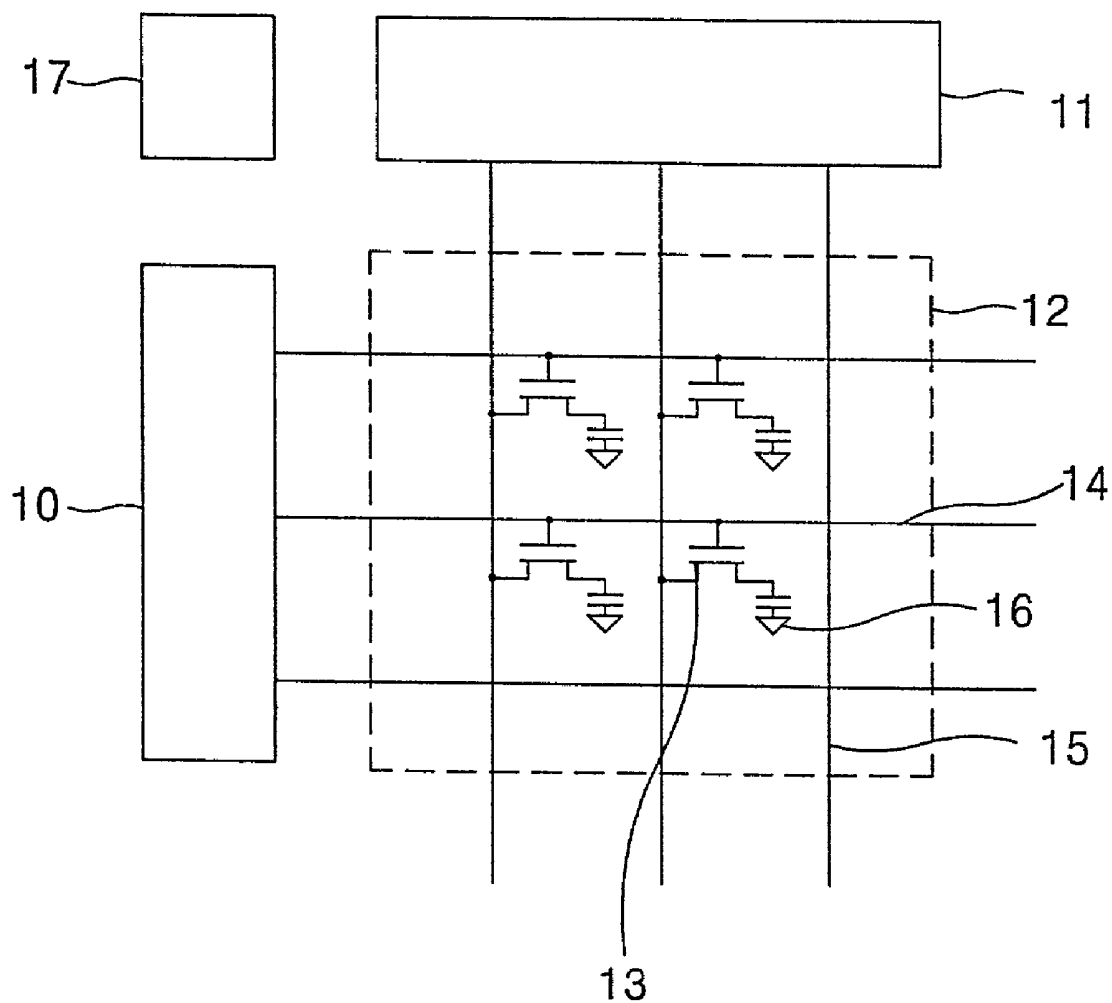

FIG. 3
CONVENTIONAL ART

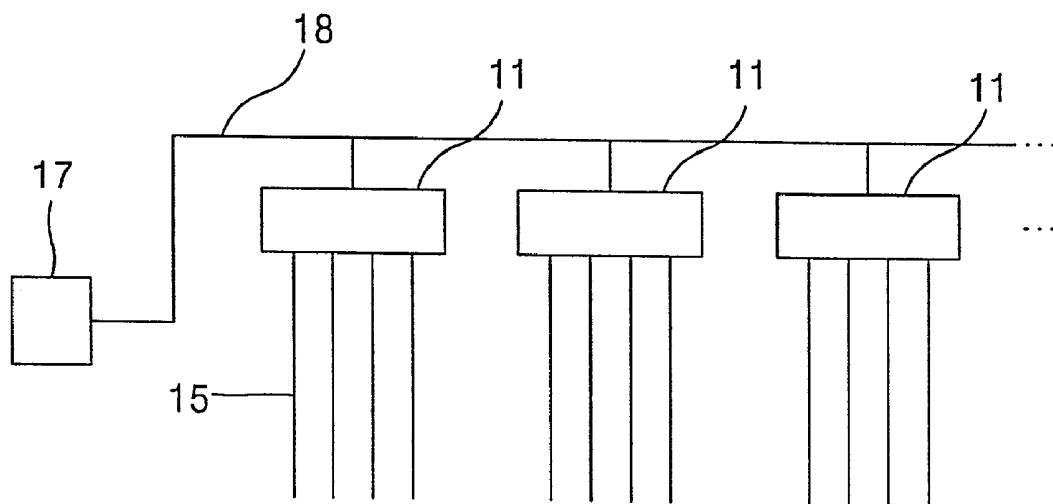

FIG. 4
CONVENTIONAL ART



FIG. 5
CONVENTIONAL ART

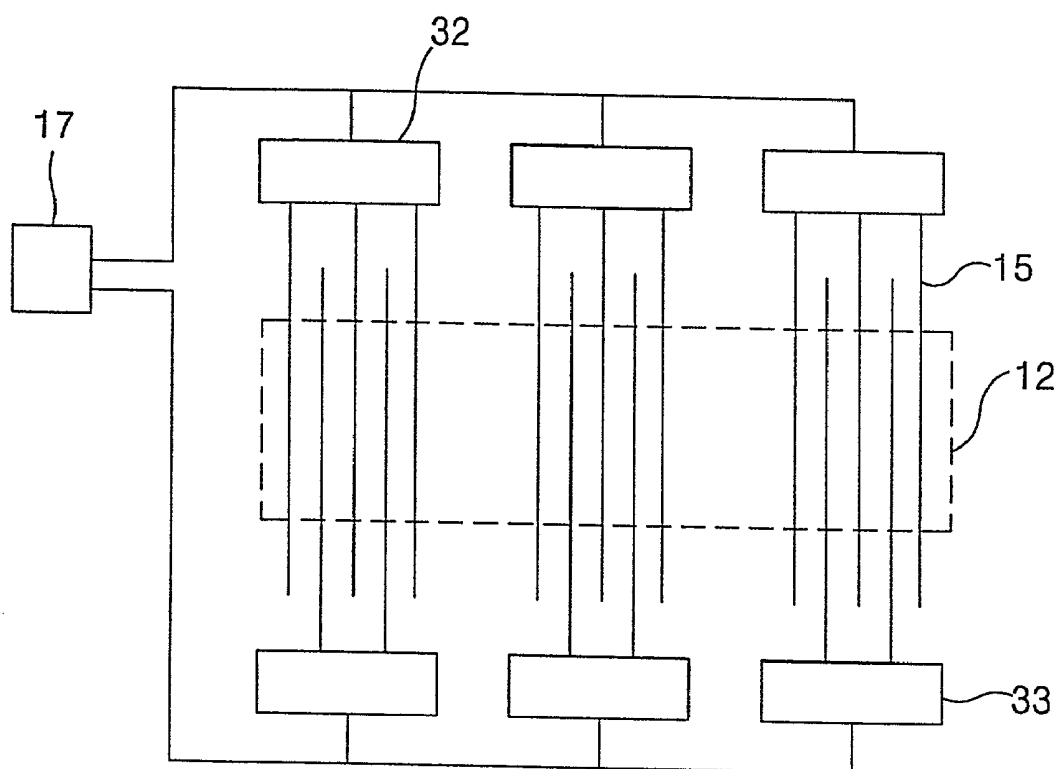

FIG. 7

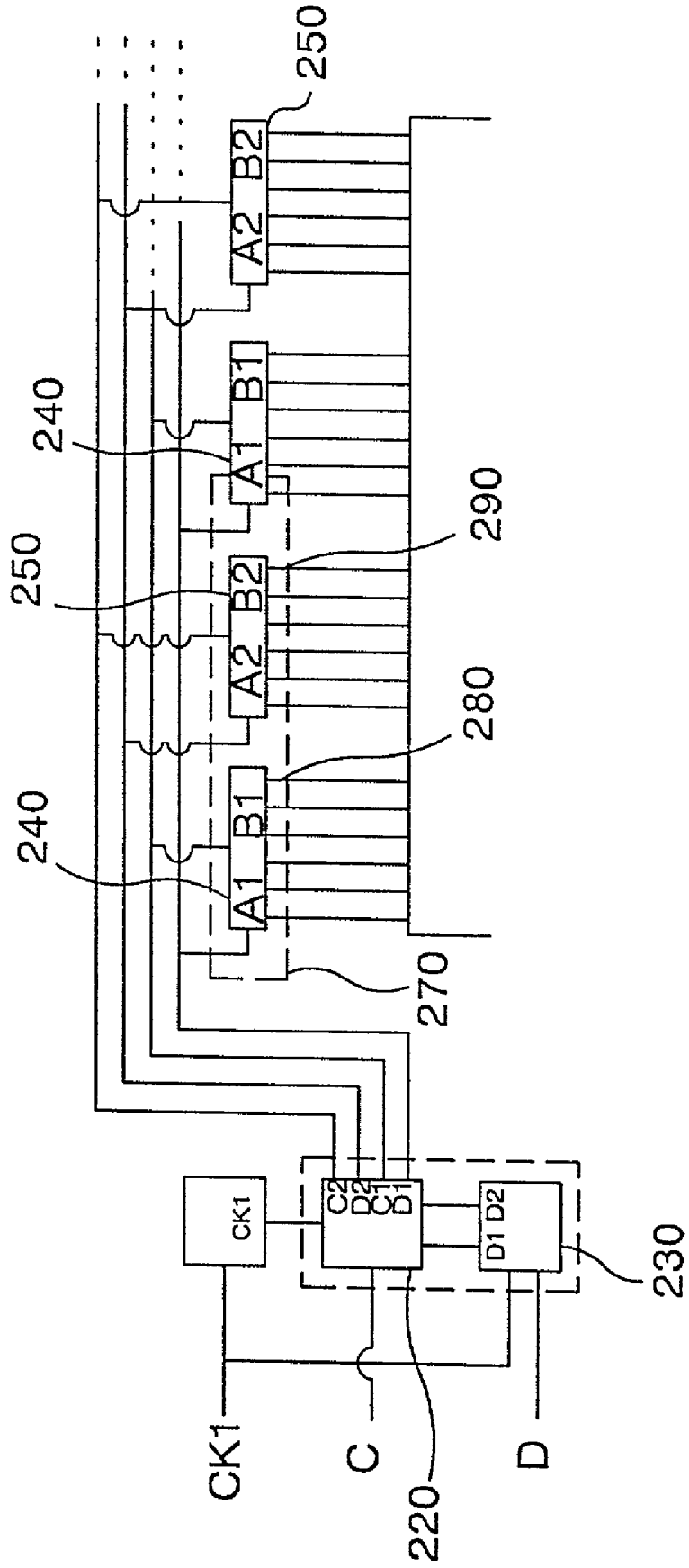

FIG. 8

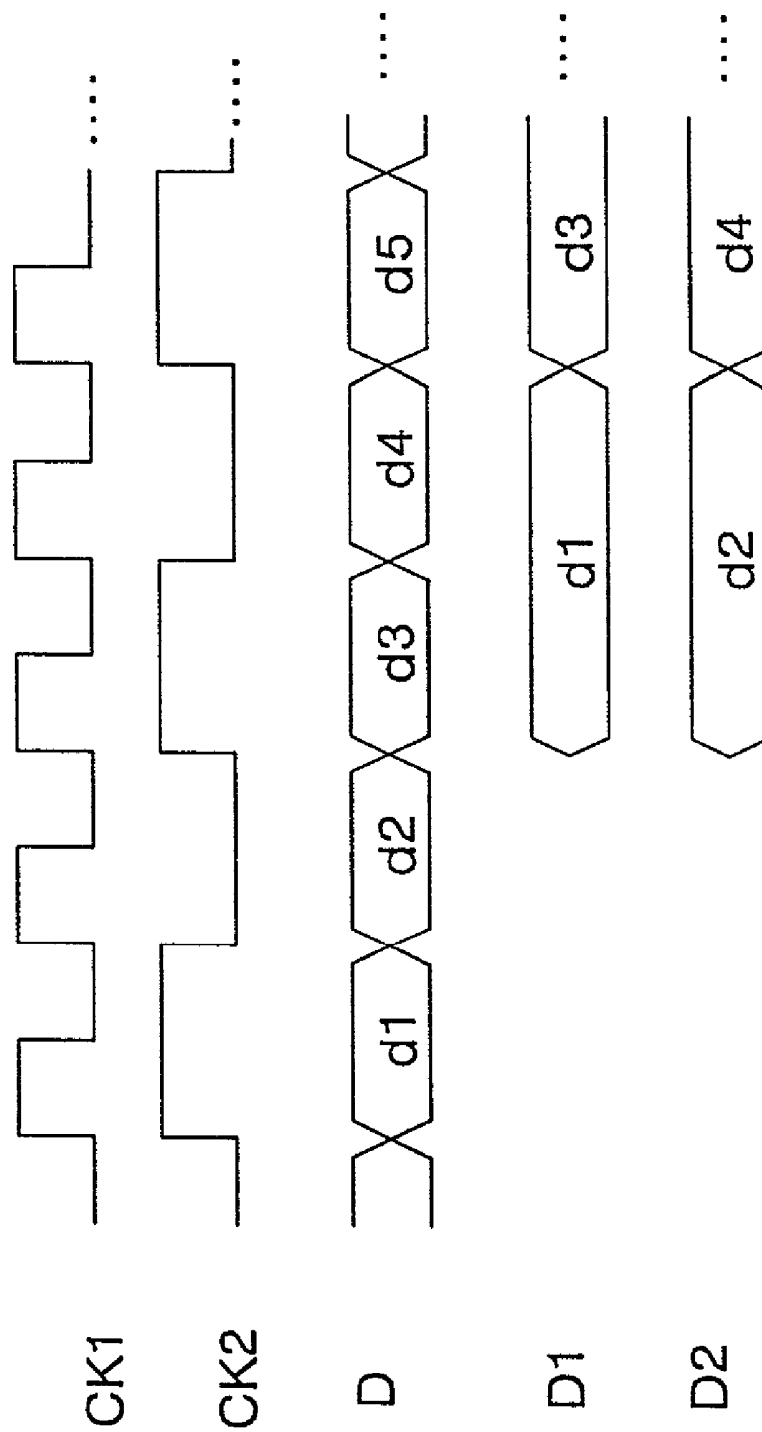

FIG. 9

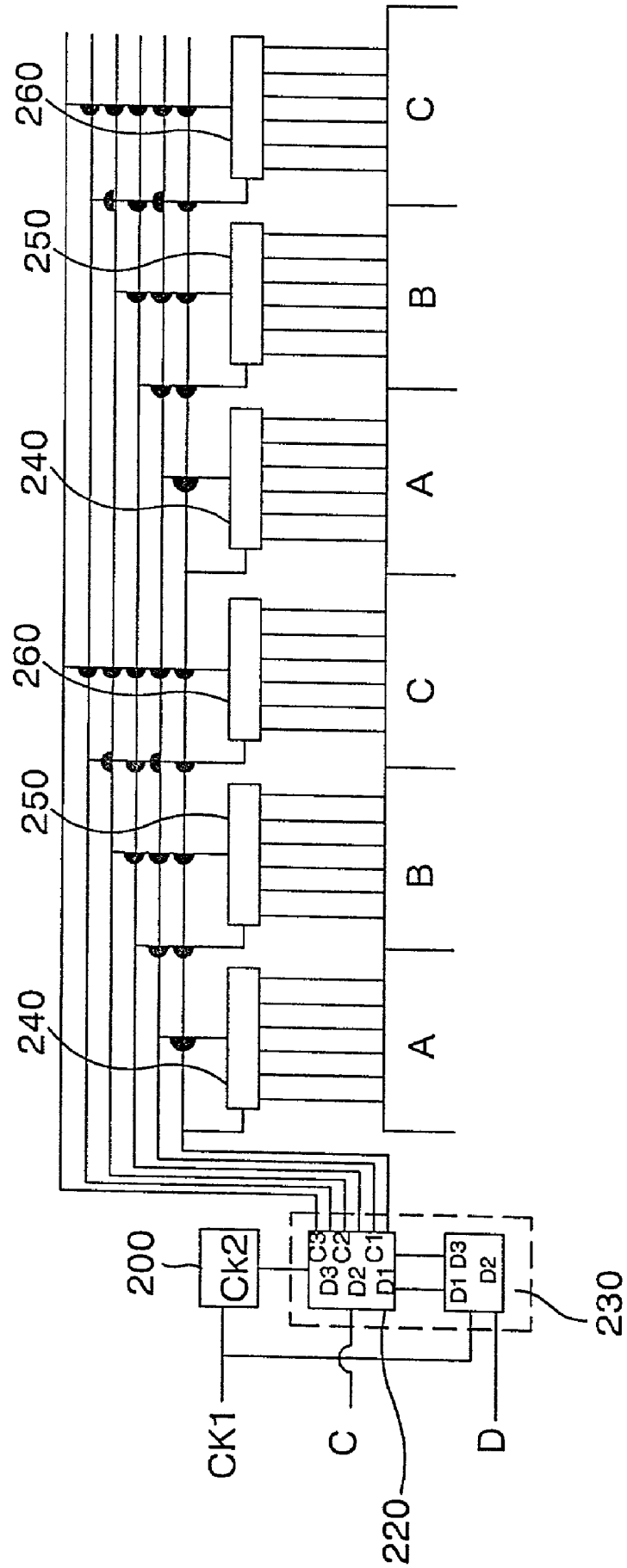
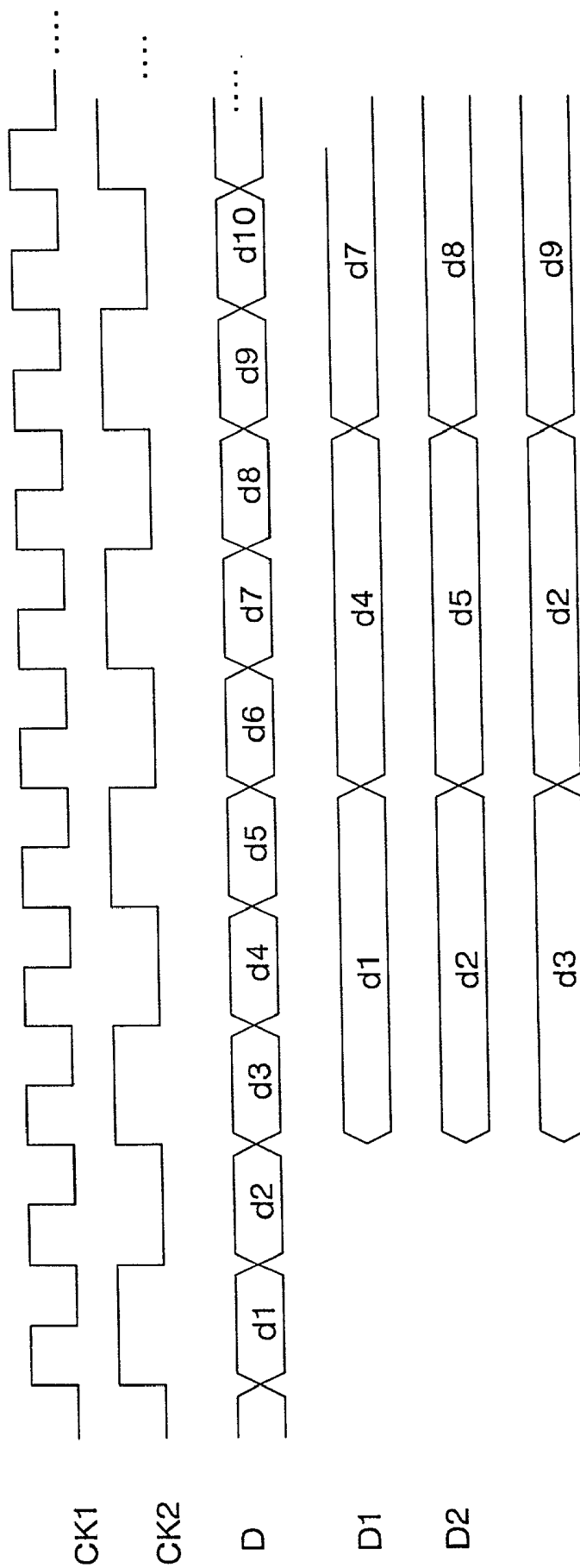

FIG. 10



DRIVING CIRCUIT WITH LOW OPERATIONAL FREQUENCY FOR LIQUID CRYSTAL DISPLAY

[0001] This application claims the benefit of Korean Application No. P97-19027, filed in Korea on May 16, 1997, which is hereby incorporated by reference.

BACKGROUND OF THE INVENTION

[0002] 1. Field of the Invention

[0003] The present invention relates to a liquid crystal display (LCD), and more particularly, to a driving circuit for driving the LCD.

[0004] 2. Discussion of the Related Art

[0005] Cathode ray tubes (CRTs) are widely used in display devices for television sets and display monitors for computers, because a CRT can easily reproduce color and it has high respond speed. However, CRTs are too large, heavy and consume too much power to be portable. Because of this, it is desirable to replace the CRT with other types of display. To overcome the above mentioned disadvantages of the CRT, a considerable amount of research and development has been conducted to design alternative types of display, such as liquid crystal displays, plasma display panels, and so on. Among them, a liquid crystal display is one of the most generally used devices because the LCD does not have the bulky electron gun like the CRT, and the LCD can be applied to a thin television set to be mounted on the wall. Furthermore, the LCD can be applied to a portable display device, such as a note-book computer, because the power consumption is very low, and accordingly, the LCD can be driven by a battery.

[0006] The schematic structure of a conventional LCD is shown in FIGS. 1 and 2. FIG. 1 shows the perspective view, and FIG. 2 shows the structure of the lower panel. The LCD includes an upper panel 21, which has a polarization plate 20, a color filter 22, and a common electrode 23; a lower panel 25, which has thin film transistors (TFTs) 13 and pixel electrodes 26; and a liquid crystal material 24 inserted between the upper panel 21 and the lower panel 25. The lower panel 25 further includes a plurality of scan lines 14 and a plurality of data lines 15. The scan lines 14 and the data lines 15 perpendicularly cross each other. At the area surrounded by the neighboring scan lines and data lines, the pixel electrode 26 is formed. At each of the intersections of the scan lines and data lines, the TFT 13 is formed. Each of the area surrounded by the neighboring scan lines and data lines is called a pixel. Thus, the pixel includes the pixel electrode 26, the common electrode 23, and the liquid crystal material 24 in between. In addition, the lower panel 25 further has a data driver IC 11 connected to the data lines 15 and a scan driver IC 10 connected to the scan lines 14 (FIG. 2).

[0007] The TFT includes a gate electrode, a source electrode and a drain electrode. The gate electrode is connected to the scan line, the source electrode is connected to the data line, and the drain electrode is connected to the pixel electrode. The drain electrode and the source electrode are connected with a semiconductor layer of the TFT. The TFT works as a switch that passes a data voltage applied to the data line to the drain electrode when a scan voltage is applied to the gate electrode through the scan line. The data

voltage applied to the drain electrode is in turn applied to the pixel electrode connected to the drain electrode.

[0008] Video data are applied from a controller 17 to the data driver IC 11. The video data include grey scaled data of red (R), green (G), and blue (B), which are applied to the corresponding pixel electrodes 26. The data driver IC 11 latches the video data, which come from the controller IC 17, until all the data of one line are inputted. Then, the video data of one line is transferred to the data line, one at a time. At that time, the scan driver IC 10 applies a scan voltage to the scan line 14 connected to TFTs 13 to reproduce the video image at the pixel electrodes 26 according to the scan signal of the controller 17.

[0009] When the scan voltage is applied to a scan line, the TFTs connected to the scan line are turned on. Accordingly, the video data applied to the data lines are sent to the pixel electrodes through the TFTs. Therefore, a voltage is applied to each pixel electrode. On the other hand, constant voltage is applied to the common electrode. Accordingly, a voltage difference is formed between the pixel electrode and the common electrode, and an electric field is formed by the voltage difference. The arrangement (or orientation) of the liquid crystal molecules between the pixel and common electrodes is changed according to the electric field, and the amount of light transmission at the pixel is modulated. That is, there are differences in light transmission at the pixels applied with a data voltage and the pixels not applied with a data voltage. Using these properties of pixels, the LCD works as a display device.

[0010] Since there are many data lines in the LCD in general, a plurality of data drivers are necessary, as shown in FIG. 3. The plurality of the data driver ICs are connected to the controller IC 17 via a bus line 18. The data driver ICs 11 latch the sequentially applied video data, until video data for one line are all inputted. Then, these one-line data are sent to the data lines 15 at one time. As the number of data lines increases, a faster clock signal is required for each controller IC. That is, the frequency of the clock signal of the controller IC needs to be higher in high resolution LCD panels. As a result, the high frequency of the clock signal is one of the causes of increasing the electrical load at the controller IC and the peripheries.

[0011] To solve the problem associated with the high frequency clock signal, a divided driving method, as shown in FIG. 4, and a double bank driving method, as shown in FIG. 5, have been used for sending video data to the data driver IC.

[0012] In the divided driving method shown in FIG. 4, the data driver ICs are divided into two groups A and B, and the video data are sent to and latched at the two groups. When the video data for the first line (the first row of pixels) are applied to the controller IC 17, the controller IC 17 stores the video data for the group A and the group B in a memory. When the video data for the second line (the second row of pixels) are applied to the controller IC 17, the stored first line data are simultaneously sent to the groups A and B of data driver ICs 30, 31, respectively. Therefore, the frequency of the clock signal can be made half of that for the LCD of FIG. 3.

[0013] In the double bank driving method shown in FIG. 5, the data driver ICs are divided into two groups. One

group, an odd data driver IC group **32**, is the driver for ICs connected with the odd numbered data lines; the other group, an even data driver IC group **33**, is for the driver ICs connected to the even numbered data lines. The driver ICs are disposed at both sides of the panel. This way, the frequency of the clock signal can be made half of that for the LCD shown in **FIG. 3**.

[0014] However, in the divided driving method, it is necessary to install a number of memories for storing the video data. This is especially true for a high resolution LCD, which requires a large number of data lines, which in turn requires a large capacity in the memory for storing the video data. In the double bank driving method, since the driver ICs are disposed at the two sides of the panel, the visible area of the display panel is smaller than that for the single bank mode in which the driver ICs are disposed at only one side of the panel. Furthermore, in the COG (Chip On Glass) technique, the above mentioned problems are more serious.

SUMMARY OF THE INVENTION

[0015] Accordingly, the present invention is directed to a driving circuit for a liquid crystal display that substantially obviates the problems due to limitations and disadvantages of the related art.

[0016] An object of the present invention is to provide an improved driving circuit for a liquid crystal display that has a low power consumption and a small occupation area.

[0017] Another object of the present invention is to provide an improved driving circuit for a liquid crystal display in which the frequency of the clock signal is less than half of the conventional driving circuit with a single bank mode structure.

[0018] Additional features and advantages of the invention will be set forth in the description that follows, and in part will be apparent from the description, or may be learned by practice of the invention. The objectives and other advantages of the invention will be realized and attained by the structure particularly pointed out in the written description and claims hereof as well as the appended drawings.

[0019] To achieve these and other advantages and in accordance with the purpose of the present invention, as embodied and broadly described, the present invention provides a driving circuit for driving a liquid crystal display, including a clock generator processing a first clock signal to output a second clock signal, the clock speed of the second clock signal being half of that of the first clock signal; a memory for storing a first video data and a second video data in accordance with the first clock signal; and a data controller for simultaneously outputting the first video data and the second video data stored in the memory in accordance with the second clock signal.

[0020] In another aspect, the present invention provides a driving circuit for driving a liquid crystal display, including a clock generator processing a first clock signal to output a second clock signal, the clock speed of the second clock signal being a third of that of the first clock signal; a memory for storing a first video data, a second video data, and a third video data in accordance with the first clock signal; and a data controller for simultaneously outputting the first video data, the second video data, and the third video data stored in the memory in accordance with the second clock signal.

[0021] In another aspect, the present invention provides a driving circuit for driving a liquid crystal display, including a clock generator for processing a first clock signal to output a second clock signal, the clock speed of the second clock signal being one Nth of that of the first clock signal with N being a positive integer; a memory for storing N sets of video data in accordance with the first clock signal; and a data controller for simultaneously outputting the N sets of video data stored in the memory in accordance with the second clock signal.

[0022] In another aspect, the present invention provides a driving device for driving a liquid crystal display in accordance with an input video signal, the driving device including a memory having a plurality of memory areas; and a data processor serially sampling the input video signal in accordance with a first clock signal to temporarily store the sampled video signal in the plurality of memory areas of the memory, the data processor serially outputting the stored video signal concurrently from all of the plurality of memory areas in accordance with a second clock signal whose clock speed is slower than that of the first clock signal, the data processor constantly updating the data in the memory by the video signal that are being sampled while the previously stored video signal are being outputted from the memory.

[0023] In a further aspect, the present invention provides a liquid crystal display device displaying a video image in accordance with an input video signal, the liquid crystal display including a first substrate including a plurality of data lines, a plurality of scan lines substantially perpendicularly crossing with the plurality of scan lines, a plurality of pixel electrodes each disposed at areas surrounded by the scan lines and data lines, and a plurality of thin film transistors each disposed at the respective intersection of the data lines and the scan lines, the gate of the thin film transistor being connected to the adjacent scan line, the source of the thin film transistor being connected to the adjacent data line, and the drain of the thin film transistor being connected to the adjacent pixel electrode; a second substrate opposite the first substrate; a liquid crystal material interposed between the first substrate and the second substrate; a memory having a plurality of memory areas; a data processor serially sampling the input video signal in accordance with a first clock signal to temporarily store the sampled video signal in the plurality of memory areas of the memory, the data processor serially outputting the stored video signal concurrently from all of the plurality of memory areas in accordance with a second clock signal whose clock speed is slower than that of the first clock signal, the data processor constantly updating the data in the memory by the video signal that are being sampled while the previously stored video signal are being outputted from the memory; and a plurality of data drivers connected to the data lines for latching the video signal outputted from the data processor to simultaneously output pixel driving signals for one row of the pixels to the plurality of data lines on the first substrate.

[0024] It is to be understood that both the foregoing general description and the following detailed description are exemplary and explanatory and are intended to provide further explanation of the invention as claimed.

BRIEF DESCRIPTION OF THE DRAWINGS

[0025] The accompanying drawings, which are included to provide a further understanding of the invention and are incorporated in and constitute a part of this specification, illustrate embodiments of the invention and together with the description serve to explain the principles of the invention.

[0026] In the drawings:

[0027] **FIG. 1** is a perspective schematic view of a conventional liquid crystal display device;

[0028] **FIG. 2** schematically shows the structure of the lower panel of the LCD of **FIG. 1**;

[0029] **FIG. 3** schematically shows the arrangement of data driver ICs in the LCD of **FIG. 1**;

[0030] **FIG. 4** shows the arrangement of data driver ICs using a conventional divided driving method for an LCD;

[0031] **FIG. 5** shows arrangement of data driver ICs using a conventional double bank method for an LCD in conventional art;

[0032] **FIG. 6** shows a structure of an LCD according to a first preferred embodiment of the present invention;

[0033] **FIG. 7** is a block diagram showing the driving circuit for an LCD according to the first preferred embodiment of the present invention;

[0034] **FIG. 8** shows waveforms of signals input to or output from the driving circuit of **FIG. 7**;

[0035] **FIG. 9** is a block diagram showing a driving circuit for an LCD according to a second preferred embodiment of the present invention; and

[0036] **FIG. 10** shows waveforms of signals input to or output from the driving circuit of **FIG. 9**.

DETAILED DESCRIPTION OF THE PREFERRED EMBODIMENTS

[0037] Reference will now be made in detail to the preferred embodiments of the present invention, examples of which are illustrated in the accompanying drawings.

[0038] In the present invention, the display panel **100** is divided into a plurality of areas (as shown in **FIG. 6**, for example). At one side of the panel **100**, a driver IC **120** is disposed for each divided area. The driver ICs **120** are grouped into two groups, an odd group and an even group, for example. The driving circuit is designed to apply the video data to the driver ICs **120** at the same time. Thus, the present invention has a single bank structure, and its frequency is less than half of the conventional driving circuit.

[0039] FIRST PREFERRED EMBODIMENT

[0040] As shown in **FIG. 7**, driving circuit according to a first preferred embodiment of the present invention includes a clock generator **200** having an input terminal for receiving a first clock signal **CK1** and an output terminal for outputting a second clock signal **CK2**; a data controller **210** having an input terminal for receiving a data signal **D** and output terminals for outputting an odd video signal **D1**, an odd control signal **C1**, an even video signal **D2**, and an even control signal **C2**; a plurality of odd data driver ICs **240** each

having a control input terminal **B1** connected to the odd control signal terminal **C1**, a data input terminal **A1** connected to the odd video signal terminal **D1**, and odd data output terminals **280**; and a plurality of even data driver ICs each having a control input terminal **B2** connected to the even control signal terminal **C2**, a data input terminal **A2** connected to the even video signal terminal **D2**, and even data output terminals **290**. The data controller **210** includes a memory **230** having an odd memory **230a** for storing the odd video signals during the odd numbered pulses of the first clock signal; an even memory **230b** for storing the even video signals during the even numbered pulses of the first clock signal; and a controller **220** for controlling input and output of the video data. Here, the memory **230**, the clock generator **200**, and the controller **220** may be integrated on a single IC chip. Also, the paired driver ICs **240**, **250** can be integrated on a single IC chip **270**.

[0041] Referring to **FIG. 8**, which shows the waveforms of the signals input into the output from the driving circuit of the present embodiment, the driving operation is explained. In **FIG. 8**, the driving process, in which line video data of one-page video data are reproduced, is explained. In the controller IC, a first clock signal is applied. Then, clock generator **200** produces the second clock signal **CK2**, the period of which is twice that of the first clock signal **CK1**: i.e., the clock speed of the second clock signal **CK2** is half that of the first clock signal **CK1**. According to the first clock signal **CK1**, the first odd data (video signal) **d1** is stored in the odd memory **230a** and the first even data (video signal) **d2** is stored in the even memory **230b**. According to the second clock signal **CK2**, the first odd data **d1** and the first even data **d2** are sent to the first odd data driver IC **240** and the first even data driver IC **250**, respectively. At that time, the second odd data **d3** is stored to the odd memory **230a**, and the second even data **d4** is stored to the even memory **230b** according to the first clock signal **CK1**. The output of the first pair of data (**d1** and **d2**) and the input of the second pair of data (**d3** and **d4**) are performed at the same time. This is possible because the period of the second clock signal **CK2** is twice that of the time clock signal **CK1**. During the second cycle of the second clock signal **CK2** in **FIG. 8**, the data **d1** and **d2** are latched at the first odd data driver IC **240** and the first even data driver IC **250**, respectively. During the third cycle of the second clock signal **CK2** in **FIG. 8**, the data **d3** and **d4** are latched at the second odd data driver IC **240** and the second even data driver IC **250**, respectively. After the line data of the one-page data are latched at all the data driver ICs, all the latched data are sent to the data lines at one time.

[0042] SECOND PREFERRED EMBODIMENT

[0043] In the first preferred embodiment, the data driver ICs are grouped in pairs. However, the data driver ICs can be grouped into multi-pairs. The second preferred embodiment, as shown in **FIG. 9**, employs a grouping method according to three areas **A**, **B**, and **C** of the display panel. **FIG. 10** shows the waveforms input into the output from the driving circuit of the present embodiment.

[0044] According to the first clock signal **CK1**, the first data **d1** for area **A**, the first data **d2** for area **B**, and the first data **d3** for area **C** are stored in memories **230A**, **230B**, and **230C** in a memory **230**. In accordance with the second clock signal **CK3**, which is generated at a clock generator **200**, the

data d1, d2, and d3 are sent to a first A data driver IC 240', a first B data driver IC 250', and a first C data driver IC 260', respectively. Since there are three memories in the memory 230', the frequency (clock speed) of the second clock signal can be a third of that of the clock signal CK1. The cycle of the latching clock signal and the amount of the video memory, etc., are determined so as to optimize the performance of the LCD under given specifications, such as the resolution, the number of color, and the refreshing rate of the screen.

[0045] According to the present invention, the data lines of the LCD are connected to a plurality of data driver ICs. The data lines are grouped according to the number of the driver ICs and assigned with the respective driver ICs. The driver ICs are then grouped together (in pairs, for example). Thus, the driver ICs can be grouped into an odd group and an even group. In this case, the odd group driver ICs are connected to an odd memory and the even driver ICs are connected to an even memory. The capacity of each memory should be equal to or greater than the latching capacity of the driver IC. At the first cycle of a clock signal, the video data is stored in the odd and even memory, such that the amount of stored data is the same as the latching amount of the paired driver ICs. At the second cycle of the clock signal, the first odd and first even driver ICs are provided with the video data stored in the odd memory and the even memory, respectively. At the third and fourth cycles of the clock signal, the second paired driver ICs are provided with the video data using the same method.

[0046] If an LCD panel has 960 data lines and the driver IC has 80 output terminals, then twelve driver ICs and six pairs of the driver ICs are necessary. The capacity of each memory is 80 bits.

[0047] The controller IC according to the present invention includes a memory having a smaller capacity than the conventional controller IC. The capacity of the memory is determined by the grouping method used. The period (clock speed) of the clock signals for the output of the data to the data driver IC is also determined by the grouping method. Therefore, the period of the clock signal that is equal to or longer than twice that of conventional art can be allocated to latch the data to the data driver IC. Also, the data driver ICs are disposed in the single bank mode. Therefore, the present invention achieves the low frequency of the clock signal and the small memory in the controlling circuit, and the high efficiency in panel area usage.

[0048] It will be apparent to those skilled in the art that various modifications and variations can be made in the driving circuit for an LCD of the present invention without departing from the spirit or scope of the invention. Thus, it is intended that the present invention cover the modifications and variations of this invention provided they come within the scope of the appended claims and their equivalents.

What is claimed is:

1. A driving circuit for driving a liquid crystal display, comprising:

- a clock generator processing a first clock signal to output a second clock signal, the clock speed of the second clock signal being half of that of the first clock signal;
- a memory for storing a first video data and a second video data in accordance with the first clock signal; and

- a data controller for simultaneously outputting the first video data and the second video data stored in the memory in accordance with the second clock signal.

2. The driving circuit according to claim 1, further comprising:

- a first data driver processing the first video data from the data controller to output pixel driving signals to pixels of the liquid crystal display connected to the first data driver; and

- a second data driver processing the second video data from the data controller to output pixel driving signals to pixels of the liquid crystal display connected to the second data driver.

3. The driving circuit according to claim 1, wherein the memory includes:

- a first memory for storing the first video data during a first cycle of the first clock signal; and

- a second memory for storing the second video data during a second cycle of the first clock signal.

4. A driving circuit for driving a liquid crystal display, comprising:

- a clock generator processing a first clock signal to output a second clock signal, the clock speed of the second clock signal being a third of that of the first clock signal;

- a memory for storing a first video data, a second video data, and a third video data in accordance with the first clock signal; and

- a data controller for simultaneously outputting the first video data, the second video data, and the third video data stored in the memory in accordance with the second clock signal.

5. The driving circuit according to the claim 4, further comprising:

- a first data driver processing the first video data from the data controller to output pixel driving signals to pixels of the liquid crystal display connected to the first data driver;

- a second data driver processing the second video data from the data controller to output pixel driving signals to pixels of the liquid crystal display connected to the second data driver; and

- a third data driver processing the third video data from the data controller to output pixel driving signals to pixels of the liquid crystal display connected to the third data driver.

6. The driving circuit according to the claim 4, wherein the memory includes:

- a first memory for storing the first video data during a first cycle of the first clock signal;

- a second memory for storing the second video data during a second cycle of the first clock signal; and

- a third memory for storing the third video data during a third cycle of the first clock signal.

7. A driving circuit for driving a liquid crystal display, comprising:

- a clock generator for processing a first clock signal to output a second clock signal, the clock speed of the second clock signal being one Nth of that of the first clock signal with N being a positive integer;
- a memory for storing N sets of video data in accordance with the first clock signal; and
- a data controller for simultaneously outputting the N sets of video data stored in the memory in accordance with the second clock signal.
- 8.** The driving circuit according to claim 7, further comprising N data drivers each processing the respective one of the N sets of video data from the data controller to output pixel driving signals to pixels of the liquid crystal display.
- 9.** The driving circuit according to the claim 7, wherein the memory includes N sets of memories for storing the N sets of video data, an nth memory storing an nth set of video data during an nth cycle of the first clock signal with n being a positive integer from 1 to N.
- 10.** A driving device for driving a liquid crystal display in accordance with an input video signal, the driving device comprising:
- a memory having a plurality of memory areas; and
 - a data processor serially sampling the input video signal in accordance with a first clock signal to temporarily store the sampled video signal in the plurality of memory areas of the memory, the data processor serially outputting the stored video signal concurrently from all of the plurality of memory areas in accordance with a second clock signal whose clock speed is slower than that of the first clock signal, the data processor constantly updating the data in the memory by the video signal that are being sampled while the previously stored video signal are being outputted from the memory.
- 11.** The driving device according to claim 10, further comprising a plurality of data drivers for latching the video signal outputted from the data processor to simultaneously output pixel driving signals for one row of the pixels of the liquid crystal displays.
- 12.** The driving device according to claim 10, further comprising a clock generator processing the first clock signal to output the second clock signal.
- 13.** The driving device according to claim 10, wherein the clock speed of the second clock signal is half that of the first clock signal.
- 14.** The driving device according to claim 10, wherein the clock speed of the second clock signal is a third of that of the first clock signal.
- 15.** A liquid crystal display device displaying a video image in accordance with an input video signal, the liquid crystal display comprising:
- a first substrate including;
 - a plurality of data lines,
 - a plurality of scan lines substantially perpendicularly crossing with the plurality of scan lines,
 - a plurality of pixel electrodes each disposed at areas surrounded by the scan lines and data lines, and
 - a plurality of thin film transistors each disposed at the respective intersection of the data lines and the scan lines, the gate of the thin film transistor being connected to the adjacent scan line, the source of the thin film transistor being connected to the adjacent data line, and the drain of the thin film transistor being connected to the adjacent pixel electrode;
 - a second substrate opposite the first substrate;
 - a liquid crystal material interposed between the first substrate and the second substrate;
 - a memory having a plurality of memory areas;
 - a data processor serially sampling the input video signal in accordance with a first clock signal to temporarily store the sampled video signal in the plurality of memory areas of the memory, the data processor serially outputting the stored video signal concurrently from all of the plurality of memory areas in accordance with a second clock signal whose clock speed is slower than that of the first clock signal, the data processor constantly updating the data in the memory by the video signal that are being sampled while the previously stored video signal are being outputted from the memory; and
 - a plurality of data drivers connected to the data lines for latching the video signal outputted from the data processor to simultaneously output pixel driving signals for one row of the pixels to the plurality of data lines on the first substrate.
- 16.** The liquid crystal display device according to claim 15, further including a scan driver for outputting scan signals to the plurality of scan lines on the first substrate to turn on the thin film transistors in synchronization with the timing of the pixel driving signals output from the plurality of data drivers.
- 17.** The liquid crystal display device according to claim 16, further comprising a clock generator processing the first clock signal to output the second clock signal.
- 18.** The liquid crystal display device according to claim 16, wherein the clock speed of the second clock signal is half that of the first clock signal.
- 19.** The liquid crystal display device according to claim 16, wherein the clock speed of the second clock signal is a third of that of the first clock signal.
- 20.** The liquid crystal display device according to claim 16, wherein the data processor is formed on the first substrate.

* * * * *

专利名称(译)	用于液晶显示器的低工作频率的驱动电路		
公开(公告)号	US20020024490A1	公开(公告)日	2002-02-28
申请号	US09/982872	申请日	2001-10-22
[标]申请(专利权)人(译)	新明CHEOL		
申请(专利权)人(译)	新明CHEOL		
当前申请(专利权)人(译)	LG DISPLAY CO. , LTD.		
[标]发明人	SHIN MIN CHEOL		
发明人	SHIN, MIN CHEOL		
IPC分类号	G09G3/36 G09G5/18		
CPC分类号	G09G3/3666 G09G3/3688 G09G5/18 G09G2352/00		
优先权	1019970019027 1997-05-16 KR		
其他公开文献	US6462727		
外部链接	Espacenet USPTO		

摘要(译)

提供一种用于驱动液晶显示器的驱动电路。驱动电路包括时钟发生器，处理第一时钟信号以输出第二时钟信号，第二时钟信号的时钟速度是第一时钟信号的时钟速度的一半，存储器用于存储第一视频数据和第二视频数据根据第一时钟信号和数据控制器，用于根据第二时钟信号同时输出存储在存储器中的第一视频数据和第二视频数据。

