



US007567329B2

(12) **United States Patent**
Jeong et al.

(10) **Patent No.:** **US 7,567,329 B2**
(45) **Date of Patent:** **Jul. 28, 2009**

(54) **LIQUID CRYSTAL DISPLAY DEVICE AND METHOD OF FABRICATING THE SAME**

7,286,203 B2* 10/2007 Kang 349/155
2004/0201803 A1 10/2004 Yang et al.
2004/0239846 A1 12/2004 Wen et al.
2005/0018113 A1 1/2005 Shen et al.

(75) Inventors: **Woo-Nam Jeong**, Gyeongsangbuk-do (KR); **Hyun-Suk Jin**, Gyeonggi-do (KR); **Won-Seok Kang**, Seoul (KR)

FOREIGN PATENT DOCUMENTS

(73) Assignee: **LG Display Co., Ltd.**, Seoul (KR)

JP	2000-187200	7/2000
JP	2000-338524	12/2000
JP	2001-142095	5/2001
JP	2001-330851	11/2001
JP	2002-156954	5/2002
JP	2002-162621	6/2002
JP	2002-258278	9/2002
JP	2002-268054	9/2002
JP	2002-277895	9/2002
JP	2002-311445	10/2002
JP	2003-029295	1/2003
KR	2003-0034855	5/2003

(*) Notice: Subject to any disclaimer, the term of this patent is extended or adjusted under 35 U.S.C. 154(b) by 635 days.

(21) Appl. No.: **11/446,399**

(22) Filed: **Jun. 5, 2006**

(65) **Prior Publication Data**

US 2006/0221279 A1 Oct. 5, 2006

Related U.S. Application Data

(62) Division of application No. 10/812,054, filed on Mar. 30, 2004, now Pat. No. 7,072,012.

(30) **Foreign Application Priority Data**

May 12, 2003 (KR) 10-2003-0029824

(51) **Int. Cl.**
G02F 1/1343 (2006.01)

(52) **U.S. Cl.** **349/145**; 349/114

(58) **Field of Classification Search** 349/113-114, 349/139, 145-146

See application file for complete search history.

(56) **References Cited**

U.S. PATENT DOCUMENTS

7,242,452 B2* 7/2007 Jeong et al. 349/145

* cited by examiner

Primary Examiner—Dung T. Nguyen

(74) *Attorney, Agent, or Firm*—Morgan Lewis & Bockius LLP

(57) **ABSTRACT**

An array substrate for a liquid crystal display device includes: a substrate; a gate line on the substrate; a data line crossing the gate line to define a pixel region including a transmissive portion and a reflective portion, the data line being divided into first and second branch lines, the first and second branch lines being spaced apart from each other and disposed in the reflective portion of the adjacent pixel regions, respectively; a thin film transistor connected to the gate line and the data line; a reflective electrode corresponding to the reflective portion and covering the first and second branch lines; and a transparent electrode corresponding to the transmissive portion and connected to the reflective electrode.

10 Claims, 9 Drawing Sheets

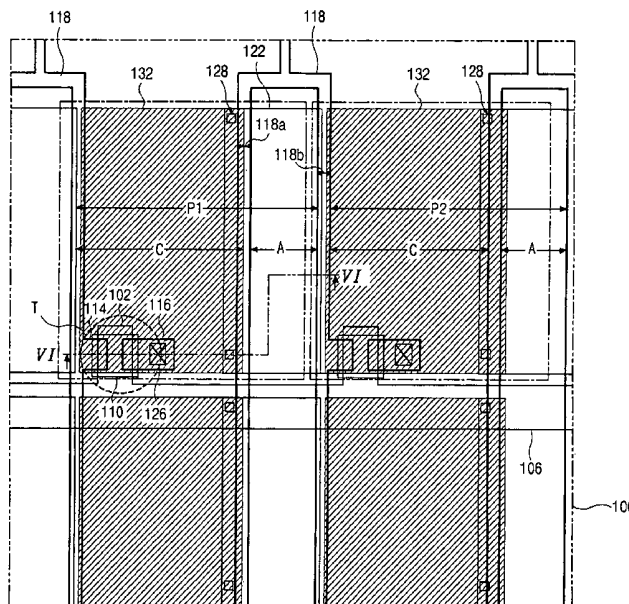

FIG. 1
RELATED ART

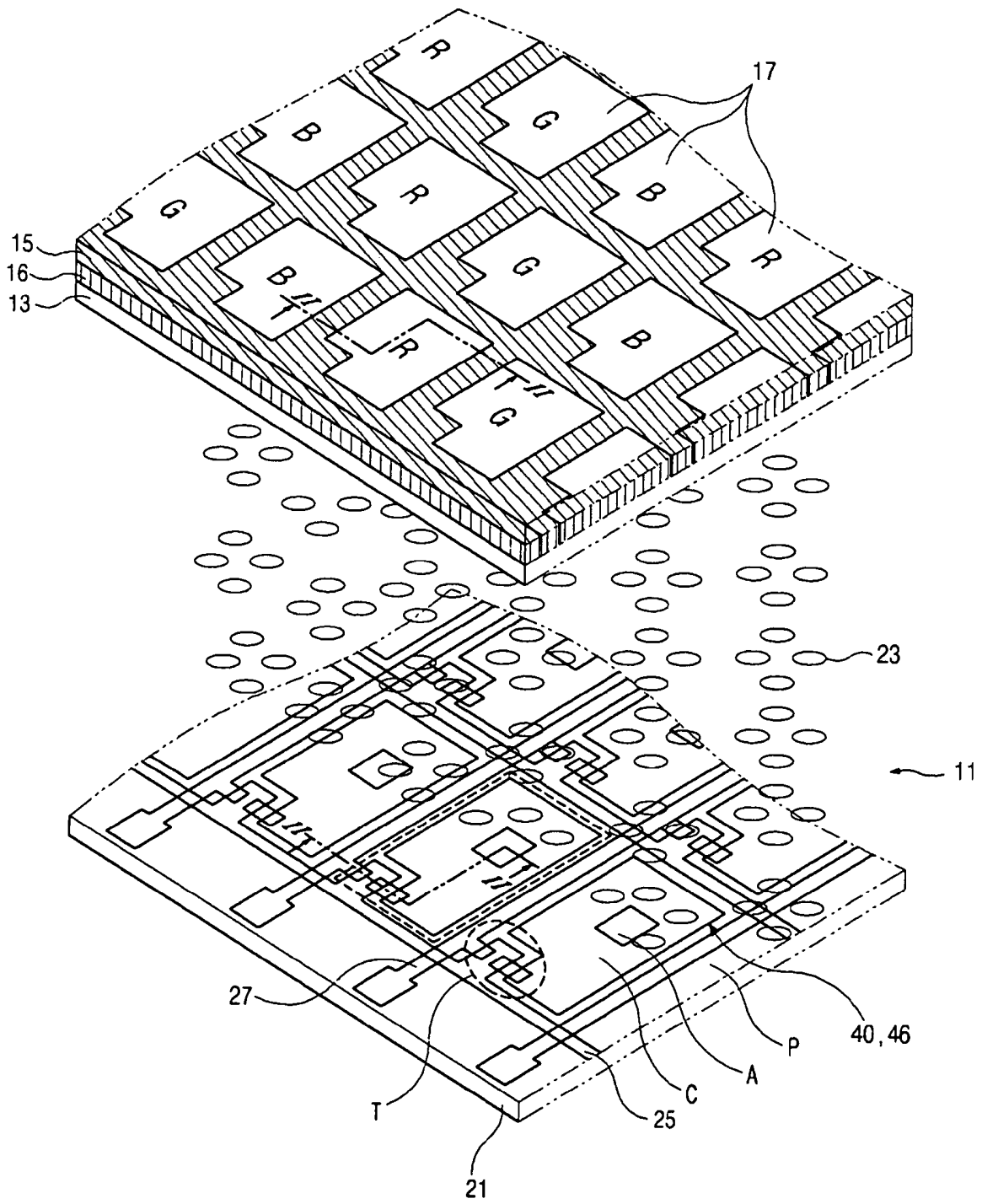

FIG. 2
RELATED ART

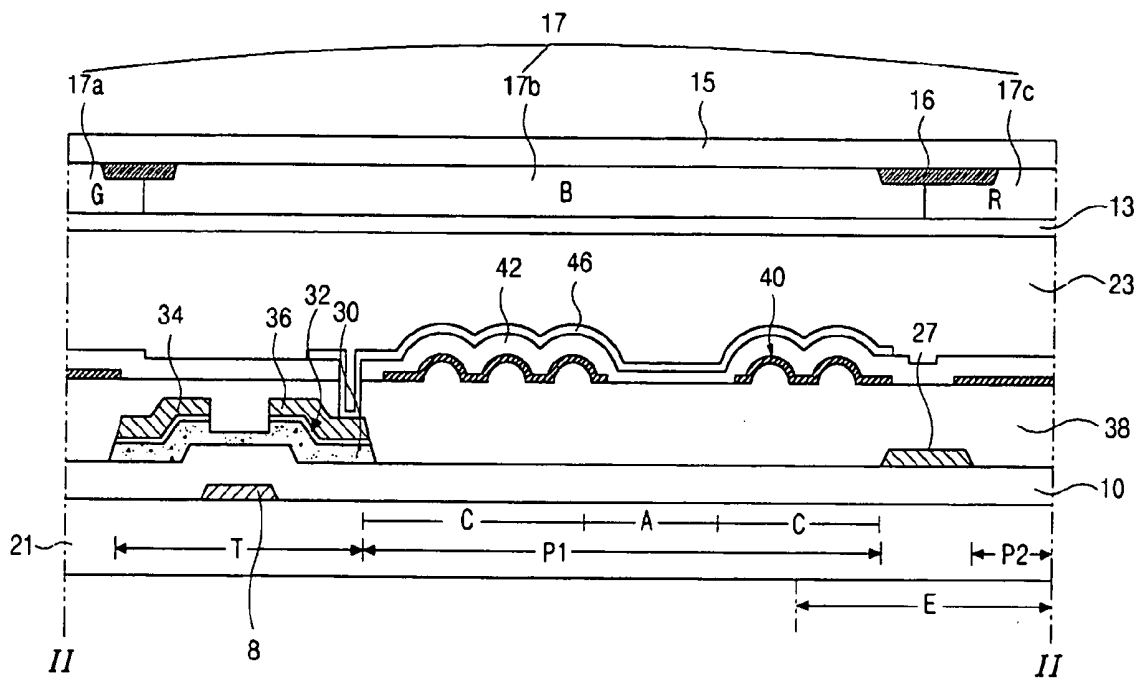

FIG. 3
RELATED ART

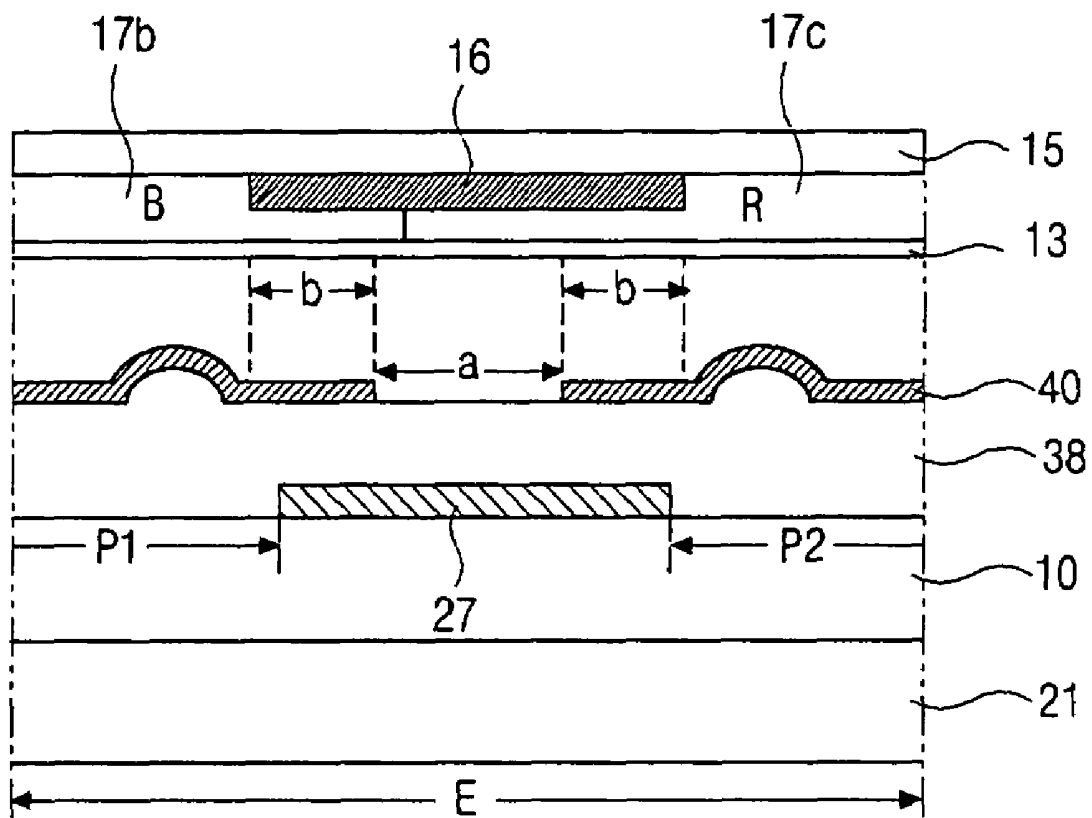

FIG. 4

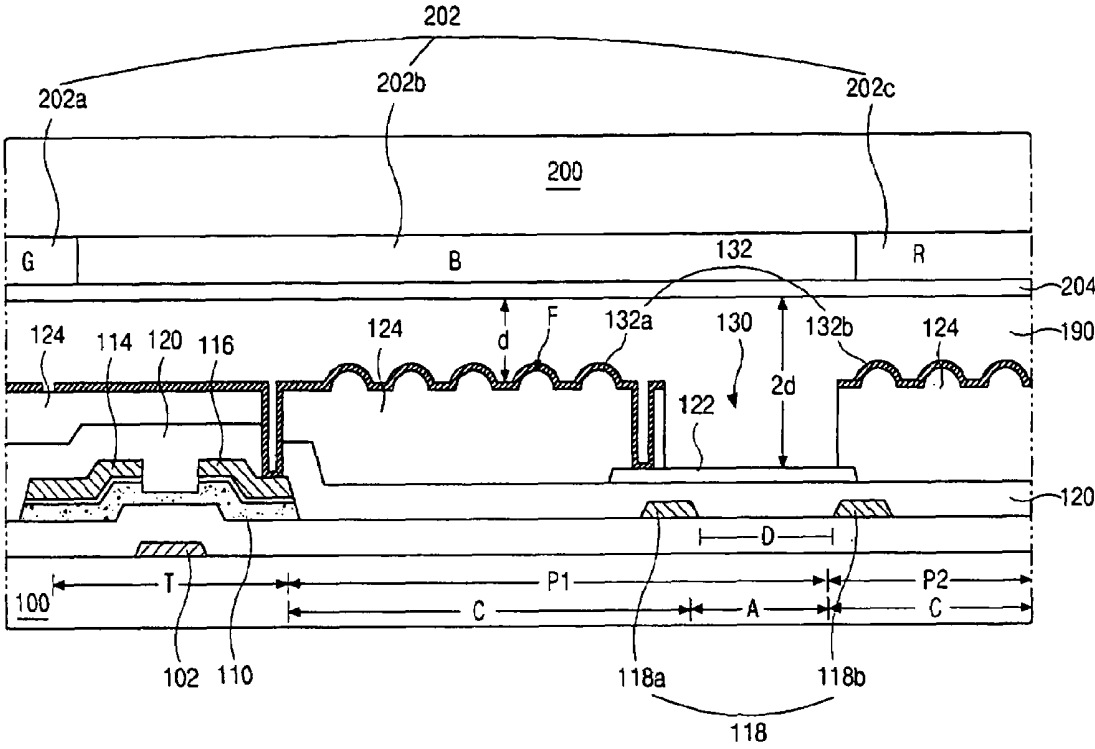

FIG. 5

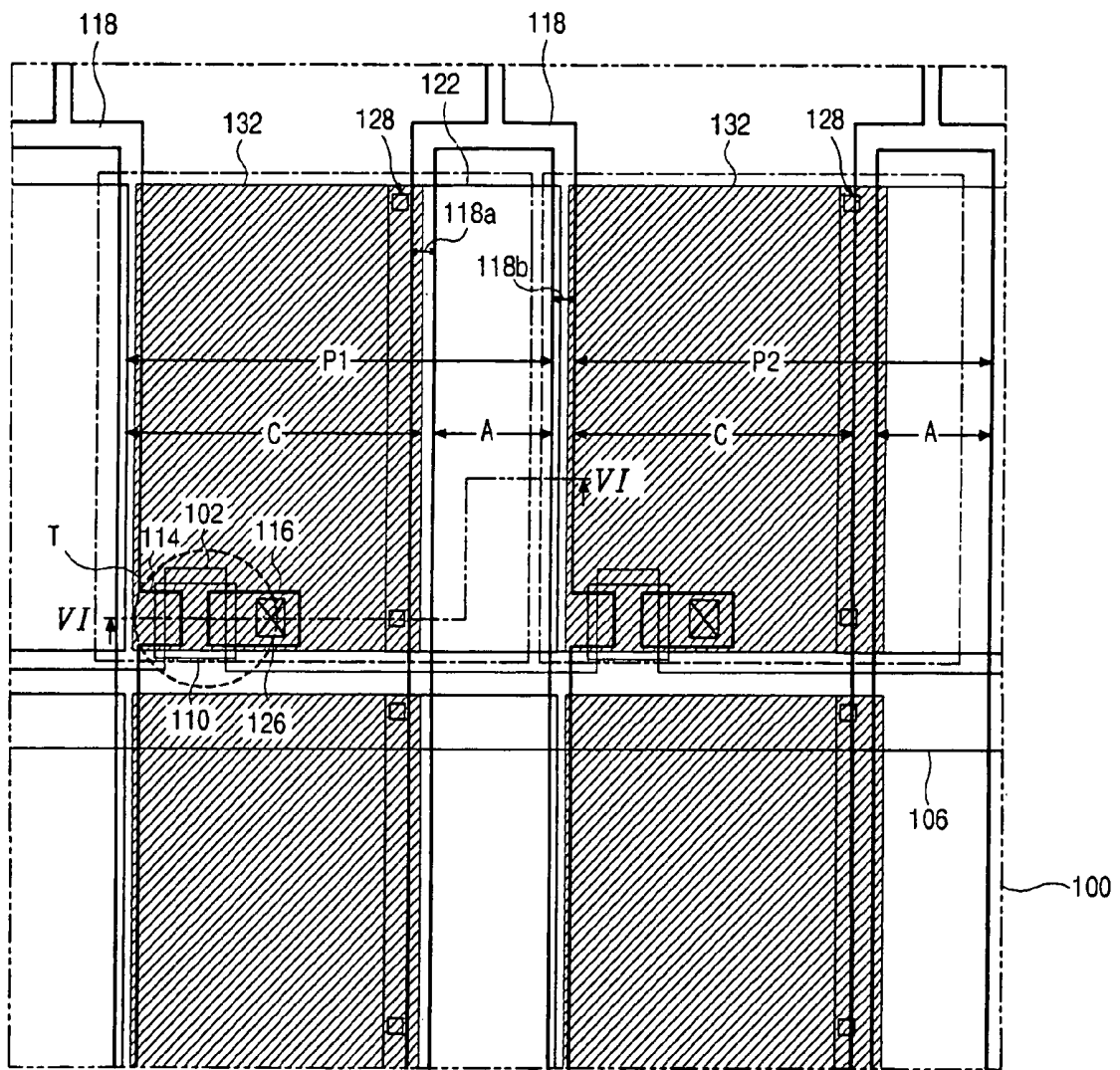

FIG. 6A

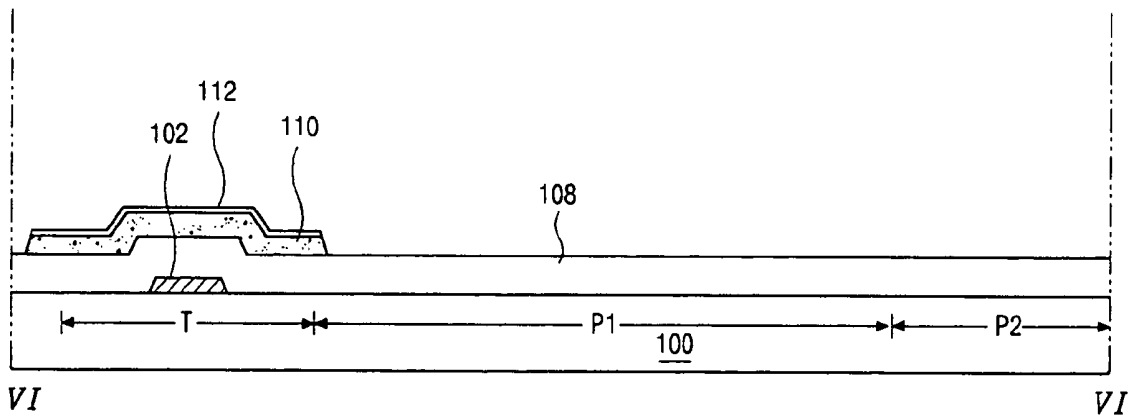

FIG. 6B

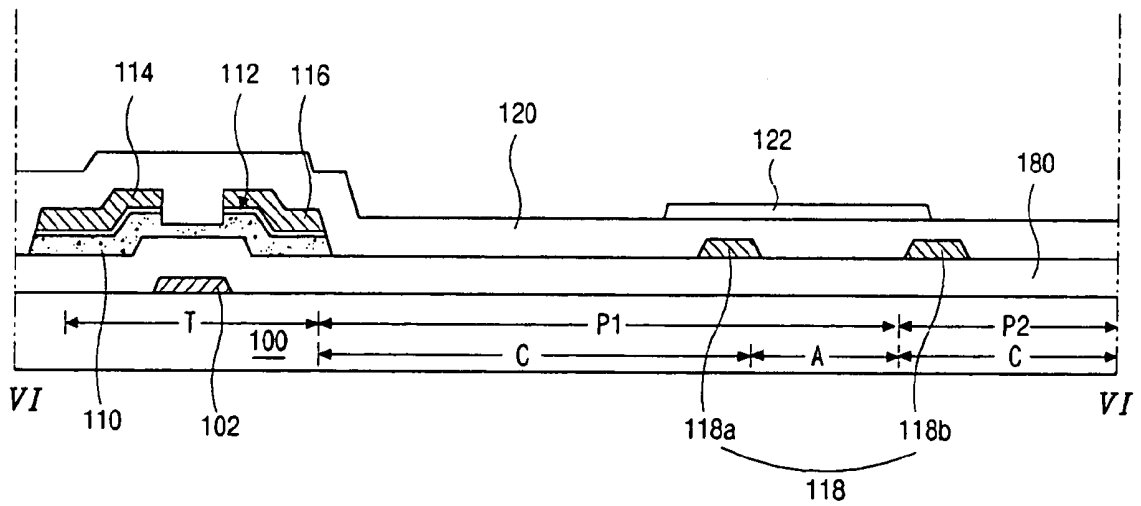

FIG. 6C

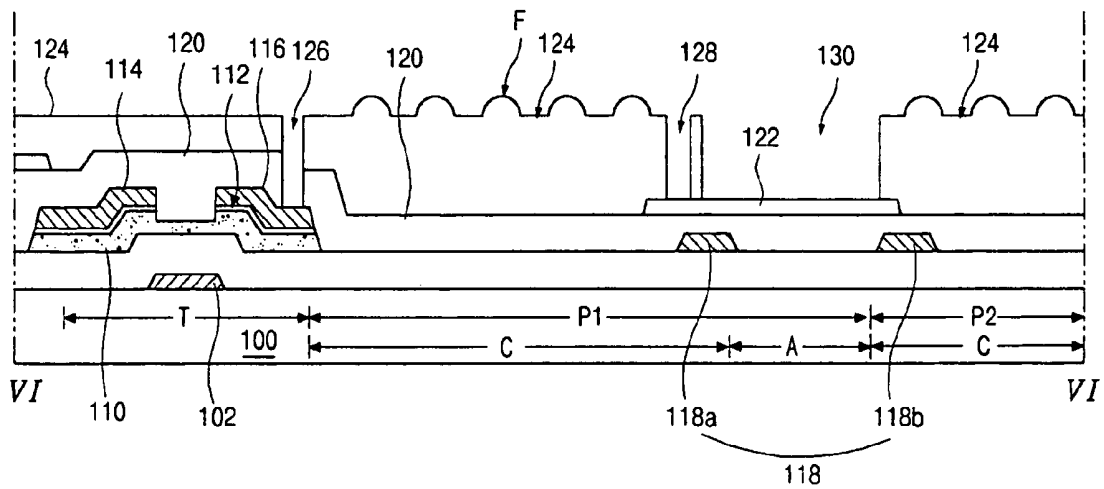

FIG. 6D

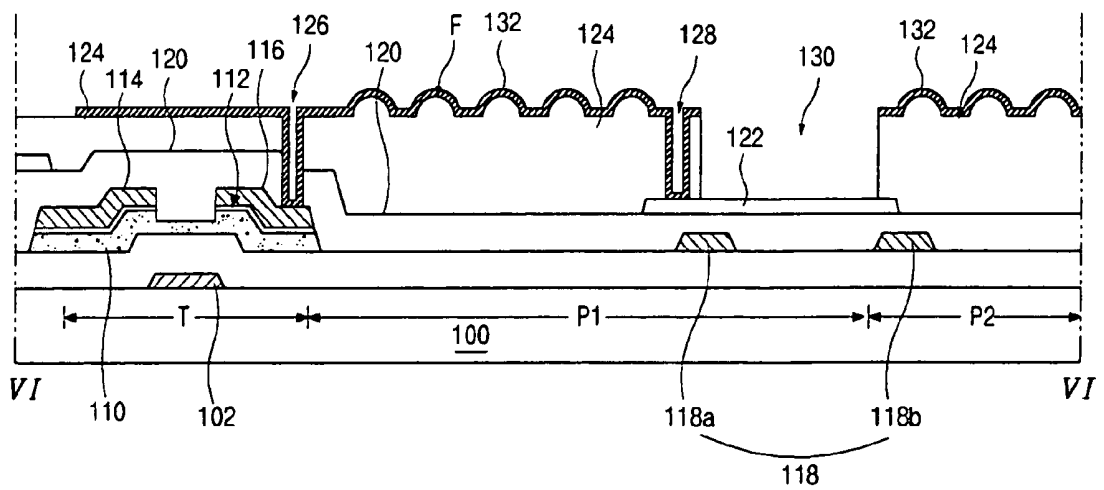
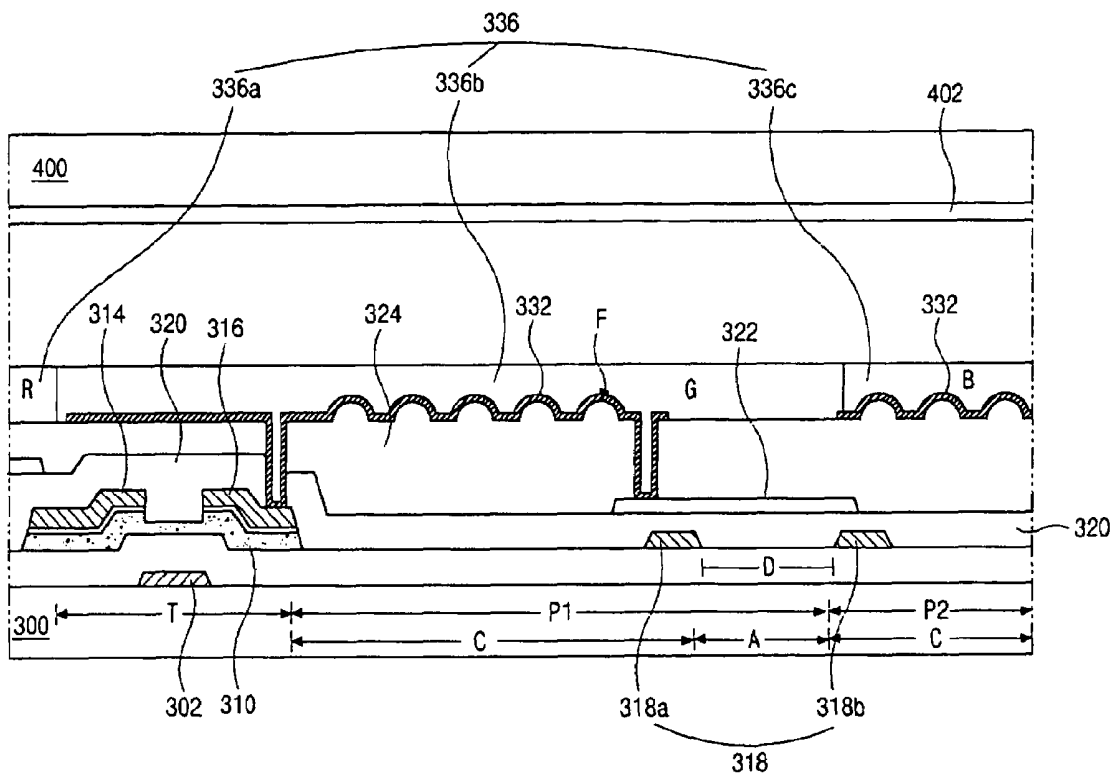

FIG. 7



LIQUID CRYSTAL DISPLAY DEVICE AND METHOD OF FABRICATING THE SAME

This application is a Divisional of U.S. patent application Ser. No. 10/812,054, Mar. 30, 2004 now U.S. Pat. No. 7,072, 012 and claims the benefit of Korean Patent Application No. 2003-29824, filed in Korea on May 12, 2003, both of which are hereby incorporated by reference.

BACKGROUND OF THE INVENTION

1. Field of the Invention

The present invention relates to a display device and a method of fabricating a display device, and more particularly, to a liquid crystal display device having a high aperture ratio and a high brightness, and a method of fabricating the same.

2. Discussion of the Related Art

In general, a transreflective liquid crystal display (LCD) device can be switched from a transmissive mode using transmission of light to a reflective mode using reflection of light according to the user's selection. Since the transreflective LCD device uses light from a backlight unit and ambient artificial or natural light, the transreflective LCD device is not restricted by environmental light and has advantages, such as low power consumption and high brightness.

FIG. 1 is an exploded perspective view of a transreflective liquid crystal display device according to the related art. In FIG. 1, a transreflective liquid crystal display (LCD) device 11 includes a first substrate 21 and a second substrate 15, and a liquid crystal layer 23 interposed therebetween. The first substrate 21 and the second substrate 15 are spaced apart from each other and include a plurality of pixel regions "P" having a transmissive portion "A" and a reflective portion "C." A black matrix 16 and a color filter layer 17 including red, green and blue sub-color filters are formed on the second substrate 15. A common electrode 13 is formed on the black matrix 16 and the color filter layer 17.

A transparent pixel electrode 46 and a reflective electrode 40 are formed on the first substrate 21. The transparent pixel electrode 46 and the reflective electrode 40 correspond to the transmissive portion "A" and the reflective portion "C," respectively. A gate line 25 formed on the first substrate 21 crosses a data line 27 to define the pixel region "P." A thin film transistor (TFT) "T" of a switching element connected to the gate line 25 and the data line 27 is disposed in matrix.

The black matrix 16 corresponding to the gate line 25, the data line 27 and the TFT "T" is designed with an alignment margin. Alignment errors between the first substrate 21 and the second substrate 15 can be compensated within the alignment margin. Accordingly, the black matrix 16 is enlarged to accommodate the alignment margin.

FIG. 2 is a schematic cross-sectional view taken along a line "II-II" of FIG. 1 and FIG. 3 is a magnified cross-sectional view of a portion "E" of FIG. 2. In FIGS. 2 and 3, a thin film transistor (TFT) "T" including a gate electrode 8, an active layer 30, an ohmic contact layer 32, a source electrode 34 and a drain electrode 36 is formed on a first substrate 21. A first pixel region "P1" and a second pixel region "P2" both contain a transmissive portion "A" and a reflective portion "C." A transparent pixel electrode 46 is formed to correspond to both the transmissive portion "A" and the reflective portion "C." A reflective electrode 40 is formed in correspondence with the reflective portion "C." A data line 27 is formed in a portion between the reflective portion "C" and the second pixel region "P2." Although not shown in FIGS. 2 and 3, a gate line crosses the data line 27.

A color filter layer 17, including a red sub-color filter 17a, green sub-color filters 17b and a blue sub-color filter 17c, is formed in the pixel regions "P1" and "P2" on a second substrate 15 facing the first substrate 21. A black matrix 16 is formed to correspond to the data line 27. When a space between the adjacent reflective electrodes 40 over the data line 27 has a first distance "a" and a portion of the reflective electrodes 40 overlapping the data line 17 have a second distance "b," the black matrix 16 has a width "a+2b."

A uniform electric field is not sufficiently applied to a liquid crystal layer corresponding to the space between the adjacent reflective electrodes 40. Accordingly, the liquid crystal layer 23 (of FIG. 2) corresponding to the space between the adjacent reflective electrodes 40 has a light leakage even when a voltage corresponding to a black image is applied to the transparent pixel electrode 46 (of FIG. 2) in a normally white mode LCD device. Thus, the liquid crystal layer 23 (of FIG. 2) corresponding to the space between the adjacent reflective electrodes 40 would be shielded by the black matrix 16. Moreover, since the first substrate 21 and second substrate 15 can have an alignment error therebetween, the black matrix is designed to have the portion having the second distance "b" corresponding to the alignment margin. Accordingly, the black matrix 16 is enlarged and an effective area of the reflective portion "C" is reduced, thereby degrading aperture ratio and brightness.

SUMMARY OF THE INVENTION

Accordingly, the present invention is directed to a liquid crystal display device and a method of fabricating a liquid crystal display device that substantially obviates one or more of the problems due to limitations and disadvantages of the related art.

An object of the present invention is to provide a liquid crystal display device having improved aperture ratio and brightness.

Another object of the present invention is to provide a method of fabricating a liquid crystal display device having improved aperture ratio and brightness.

Additional features and advantages of the invention will be set forth in the description which follows, and in part will be apparent from the description, or may be learned by practice of the invention. These and other advantages of the invention will be realized and attained by the structure particularly pointed out in the written description and claims hereof as well as the appended drawings.

To achieve these and other advantages and in accordance with the purpose of the present invention, as embodied and broadly described, an array substrate for a liquid crystal display device includes: a substrate; a gate line on the substrate; a data line crossing the gate line to define a pixel region including a transmissive portion and a reflective portion, the data line being divided into first and second branch lines, the first and second branch lines being spaced apart from each other and disposed in the reflective portion of the adjacent pixel regions, respectively; a thin film transistor connected to the gate line and the data line; a reflective electrode corresponding to the reflective portion and covering the first and second branch lines; and a transparent electrode corresponding to the transmissive portion and connected to the reflective electrode.

In another aspect, a fabricating method of an array substrate for a liquid crystal display device includes: forming a gate line on a substrate; forming a data line crossing the gate line to define a pixel region including a transmissive portion and a reflective portion, the data line being divided into first

and second branch lines, the first and second branch lines being spaced apart from each other and disposed in the reflective portion of the adjacent pixel regions, respectively; forming a thin film transistor connected to the gate line and the data line; forming a reflective electrode corresponding to the reflective portion and covering the first and second branch lines; and forming a transparent electrode corresponding to the transmissive portion and connected to the reflective electrode.

In another aspect, a liquid crystal display device includes: first and second substrates spaced apart from each other; a gate line on the first substrate; a data line crossing the gate line to define a pixel region including a transmissive portion and a reflective portion, the data line being divided into first and second branch lines, the first and second branch lines being spaced apart from each other and disposed in the reflective portion of the adjacent pixel regions, respectively; a thin film transistor connected to the gate line and the data line; a reflective electrode corresponding to the reflective portion and covering the first and second branch lines; a transparent electrode corresponding to the transmissive portion and connected to the reflective electrode; a color filter layer on the second substrate; a common electrode on the color filter layer; and a liquid crystal layer between the reflective electrode and the common electrode.

In another aspect, a liquid crystal display device includes: first and second substrates spaced apart from each other; a gate line on the first substrate; a data line crossing the gate line to define a pixel region including a transmissive portion and a reflective portion, the data line being divided into first and second branch lines, the first and second branch lines being spaced apart from each other and disposed in the reflective portion of the adjacent pixel regions, respectively; a thin film transistor connected to the gate line and the data line; a reflective electrode corresponding to the reflective portion and covering the first and second branch lines; a transparent electrode corresponding to the transmissive portion and connected to the reflective electrode; a color filter layer on the reflective electrode; a common electrode on the second substrate; and a liquid crystal layer between the color filter layer and the common electrode.

In another aspect, a fabricating method of a liquid crystal display device includes: forming a gate line on a first substrate; forming a data line crossing the gate line to define a pixel region including a transmissive portion and a reflective portion, the data line being divided into first and second branch lines, the first and second branch lines being spaced apart from each other and disposed in the reflective portion of the adjacent pixel regions, respectively; forming a thin film transistor connected to the gate line and the data line; forming a reflective electrode corresponding to the reflective portion and covering the first and second branch lines; forming a transparent electrode corresponding to the transmissive portion and connected to the reflective electrode; forming a color filter layer on a second substrate; forming a common electrode on the color filter layer; attaching the first and second substrates such that the reflective electrode faces the common electrode; and forming a liquid crystal layer between the reflective electrode and the color filter layer.

In another aspect, a fabricating method of a liquid crystal display device includes: forming a gate line on a first substrate; forming a data line crossing the gate line to define a pixel region including a transmissive portion and a reflective portion, the data line being divided into first and second branch lines, the first and second branch lines being spaced apart from each other and disposed in the reflective portion of the adjacent pixel regions, respectively; forming a thin film

transistor connected to the gate line and the data line; forming a reflective electrode corresponding to the reflective portion and covering the first and second branch lines; forming a transparent electrode corresponding to the transmissive portion and connected to the reflective electrode; forming a color filter layer on the reflective electrode; forming a common electrode on a second substrate; attaching the first and second substrates such that the color filter layer faces the common electrode; and forming a liquid crystal layer between the color filter layer and the common electrode.

It is to be understood that both the foregoing general description and the following detailed description are exemplary and explanatory and are intended to provide further explanation of the invention as claimed.

BRIEF DESCRIPTION OF THE DRAWINGS

The accompanying drawings, which are included to provide a further understanding of the invention and are incorporated in and constitute a part of this specification, illustrate embodiments of the invention and together with the description serve to explain the principles of the invention.

FIG. 1 is an exploded perspective view of a transreflective liquid crystal display device according to the related art.

FIG. 2 is a schematic cross-sectional view taken along a line "II-II" of FIG. 1.

FIG. 3 is a magnified cross-sectional view of a portion "E" of FIG. 2.

FIG. 4 is a cross sectional view of a liquid crystal display device according to a first embodiment of the present invention.

FIG. 5 is a plane view of an array substrate of a liquid crystal display device according to a first embodiment of the present invention.

FIGS. 6A to 6D are cross-sectional views, which are taken along a line "VI-VI" of FIG. 5, showing a fabricating process of an array substrate for a liquid crystal display device according to a first embodiment of the present invention.

FIG. 7 is a cross-sectional view of a liquid crystal display device according to a second embodiment of the present invention.

FIG. 8 is a cross-sectional view of a liquid crystal display device according to a third embodiment of the present invention.

DETAILED DESCRIPTION OF THE ILLUSTRATED EMBODIMENTS

Reference will now be made in detail to the illustrated embodiments of the present invention, an example of which is illustrated in the accompanying drawings.

FIG. 4 is a cross sectional view of a liquid crystal display device according to a first embodiment of the present invention. As shown in FIG. 4, a first substrate **100** and a second substrate **200** can be disposed to face and be spaced apart from each other. A thin film transistor (TFT) "T" having a gate electrode **102**, an active layer **110**, a source electrode **114** and a drain electrode **116** are formed on an inner surface of the first substrate **100**. In addition, a data line **118**, including a first branch line **118a** and a second branch line **118b**, and a gate line (not shown) are formed on an inner surface of the first substrate **100**. The data line **118** is connected to the source electrode **114**, and is divided into first branch line **118a** and a second branch line **118b** at an end portion of the first substrate **100**. The first branch line **118a** and the second branch line **118b** are spaced apart from each other to define a space "D." A width of the first branch line **118a** can be the

same as a width of the second branch line **118b**. The gate line is connected to the gate electrode **102**. The gate line and the data line **118** cross each other to define a first pixel region "P1" and a second pixel region "P2."

A first passivation layer **120** is formed on an entire surface of the first substrate **100** having the TFT "T" and the data line **118**. A transparent electrode **122** is formed on the first passivation layer **120** to correspond to the space "D" between the first branch line **118a** and the second branch line **118b**. A second passivation layer **124** is formed on the transparent electrode **122**.

A reflective electrode **132** connected to the drain electrode **116** and the transparent electrode **122** is formed on the second passivation layer **124**. The reflective electrode **122** can include an unevenness to increase brightness along a slant angle and to prevent mirror reflection. The unevenness can be indirectly obtained by forming the second passivation layer **124** to have an uneven portion "F" at a surface thereof.

The reflective electrode **132** includes a first reflective electrode **132a** in the first pixel region "P1" and a second reflective electrode **132b** in the second pixel region "P2" adjacent to the first pixel region "P1." The first branch line **118a** and the second branch line **118b** are formed under the first reflective electrode **132a** and the second reflective electrode **132b**, respectively. Since the transparent electrode **122** connected to the drain electrode **116** is formed in the space "D" between the first branch line **118a** and the second branch line **118b**, light from a backlight unit (not shown) under the first substrate **100** passes through the space "D" and is emitted to exterior. Accordingly, the space "D" and the reflective electrode **132** corresponds to a transmissive portion "A" and a reflective portion "C," respectively. Each pixel region "P1" and "P2" includes the transmissive portion "A" and the reflective portion "C." The second passivation layer **124** can be formed to have a groove **130** corresponding to the transmissive portion "A" for a dual cell gap.

A color filter layer **202**, including a red sub-color filter **202a**, a green sub-color filter **202b** and a blue sub-color filter **202c**, is formed on an inner surface of the second substrate **200**, and a transparent common electrode **204** is formed on the color filter layer **202**. A liquid crystal layer **190** is formed between the reflective electrode **132** and the common electrode **204**. When the second passivation layer **124** has the groove **130** corresponding to the transmissive portion "A," the liquid crystal layer **190** can have a first thickness "2d" in the transmissive portion "A" and a second thickness "d" in the reflective portion "C," wherein the first thickness "2d" is substantially twice as great as the second thickness "d."

In the first embodiment, since the data line **118** is formed under the reflective electrode **132** in the reflective portion "C" of the first region "P1" and the second pixel region "P2," a black matrix corresponding to the data line **118** can not be formed on the second substrate **200**. Moreover, since the transparent electrode **122** is formed in the space "D" between the first branch line **118a** and the second branch line **118b**, a black matrix corresponding to the space "D" may not be necessary. In addition, since the space "D" between the first branch line **118a** and the second branch line **118b** is used as the transmissive portion "A," aperture ratio is further improved.

FIG. 5 is a plane view of an array substrate of a liquid crystal display device according to a first embodiment of the present invention. As shown in FIG. 5, a gate line **106** and a data line **118** cross each other to define a first region "P1" and a second pixel region "P2" that both respectively include a transmissive portion "A" and a reflective portion "C." The data line **118** is divided into a first branch line **118a** and a

second branch line **118b** at an end of a substrate **100**. A thin film transistor (TFT) "T," including a gate electrode **102**, an active layer **110**, a source electrode **114** and a drain electrode **114**, is formed near the crossing of the gate line **106** and the data line **118**. The gate electrode **102** is connected to the gate line **106** and the source electrode **114** is connected to the data line **118**. The source electrode **114** and the drain electrode **116** are spaced apart from each other.

A transparent electrode **122** is formed to correspond to the transmissive portion "A" of the first regions "P1" and the second pixel region "P2." A reflective electrode **132** having an unevenness (not shown) is formed to correspond to the reflective portion "C." The reflective electrode **132** is connected to the drain electrode **116** through a drain contact hole **126**. Further, the reflective electrode **132** is connected to the transparent electrode **122** through a transparent electrode contact hole **128**. The first branch line **118a** and second branch line **118b** are formed under the reflective electrodes in the first pixel region "P1" and the second pixel region "P2," respectively. Widths of the first branch line **118a** and second branch line **118b** can be determined such that a sum of the widths of the first branch line **118a** and second branch line **118b** is substantially the same as a width of the data line **27** discussed above in reference to FIG. 2 for an LCD device of the related art so as not to affect the resistance of the data line **118**. In addition, a width of the first branch line **118a** is substantially the same as a width of the second branch line **118b**. Moreover, the first branch line **118a** and second branch line **118b** can have at least one connection pattern (not shown) connecting the first branch line **118a** and second branch line **118b** of one data line **118**. Such a connection pattern can overlap the gate line **106**.

In the first embodiment, since the data line **118** is formed under the reflective electrode **132** in the reflective portion "C" of both the first and second pixel regions "P1" and "P2," a black matrix corresponding to the data line **118** can be omitted. Moreover, since the transparent electrode **122** is formed in a space "D" between the first branch line **118a** and second branch line **118b**, a black matrix corresponding to the space "D" can also be omitted. In addition, since the space "D" between the first branch line **118a** and second branch line **118b** is used as the transmissive portion "A," aperture ratio and brightness are further improved.

FIGS. 6A to 6D are cross-sectional views, which are taken along a line "VI-VI" of FIG. 5, showing a fabricating process of an array substrate for a liquid crystal display device according to a first embodiment of the present invention. As shown in FIG. 6A, a gate line **106**, as described in reference to FIG. 5, and a gate electrode **102** are formed on a substrate **100**. Since resistance of the gate line **106** causes an RC (resistance-capacitance) delay, a material having low resistance can be used for the gate line **106**. For example, aluminum (Al) can be used for the gate line **106** to reduce RC delay. Pure aluminum (Al), however, has low chemical resistance and may cause line defects, such as a hillock, in a subsequent high temperature process. Accordingly, aluminum (Al) alloy, such as aluminum neodymium (AlNd), and a multiple layer including an aluminum layer, such as aluminum/molybdenum (Al/Mo), can be used for the gate line **106**.

A gate insulating layer **108** is formed on an entire surface of the substrate **100** including the gate line **106** and the gate electrode **102**. The gate insulating layer can include an inorganic material, such as silicon nitride (SiN_x) and silicon oxide (SiO₂). An active layer **110** of amorphous silicon (a-Si:H) and an ohmic contact layer **112** of impurity-doped amorphous silicon (n+a-Si:H) are sequentially formed on the gate insu-

lating layer **108**. The active layer **110** and the ohmic contact layer **112** have an island shape.

As shown in FIG. 6B, a source electrode **114** and a drain electrode **116** are formed on the ohmic contact layer **112** by depositing and patterning one of a conductive metal group including chromium (Cr), molybdenum (Mo), antimony (Sb) and titanium (Ti). At the same time, a data line **118** can be formed on the gate insulating layer **108**. The data line **118** is connected to the source electrode **114** and crosses the gate line **106** to define a first pixel region "P1" and a second pixel region "P2" that both include a transmissive portion "A" and a reflective portion "C." The data line **118** is divided into a first branch line **118a** and a second branch line **118b** at one end of the substrate **100**. The first branch line **118a** and second branch line **118b** are disposed in the reflective portions "C" of the adjacent first pixel region "P1" and the second pixel region "P2," respectively. The first branch line **118a** and second branch line **118b** can have at least one connection pattern (not shown) connecting the first branch line **118a** and second branch line **118b** of one data line **118**. Such a connection pattern can overlap the gate line **106**.

A first passivation layer **120** of an organic insulating material, such as benzocyclobutene (BCB) and acrylic resin, is formed on an entire surface of the substrate **100** including the source electrode **114**, the drain electrode **116** and the data line **118**. A transparent electrode **122** is formed on the first passivation layer **120** by depositing and patterning a transparent conductive material, such as indium-tin-oxide (ITO) and indium-zinc-oxide (IZO). The transparent electrode **122** can be formed to correspond to the transmissive portion "A," which is defined by a space between the first branch line **118a** and second branch line **118b**. The transparent electrode **122** extends such that one side of the transparent electrode **122** is formed in the reflective portion "C."

As shown in FIG. 6C, a second passivation layer **124** of an organic insulating material, such as benzocyclobutene (BCB) and acrylic resin, is formed on an entire surface of the substrate **100**, including the transparent electrode **122**. The second passivation layer **124** has an uneven portion "F" on its surface corresponding to the reflective portion "C." The uneven portion "F" can be obtained through several processes. For example, a first uneven pattern having a rectangular shape in a cross-sectional view can be formed by depositing and patterning a photosensitive resin. The first uneven pattern can be cured to become a second uneven pattern having a semi-spherical shape in a cross-sectional view.

A drain contact hole **126** exposing the drain electrode **116**, a transparent electrode contact hole **128** exposing the transparent electrode **122** in the reflective portion "C" and a groove **130** exposing the transparent electrode **122** in the transmissive portion "A" are formed by patterning the first passivation layer **120** and the second passivation layer **124**. The groove **130** corresponding to the transmissive portion "A" is formed to obtain a dual cell gap, where a first thickness "2d," as discussed above in reference to FIG. 4, (i.e., a first cell gap) in the transmissive portion "A" is substantially twice as great as a second cell gap "d," as also discussed above in reference to FIG. 4, (i.e., a second cell gap) in the reflective portion "C." In a structure having a dual cell gap, since the polarization property of the transmissive portion becomes similar to that of the reflective portion, color difference between the transmissive portion and the reflective portion is reduced.

As shown in FIG. 6D, a reflective electrode **132** is formed on the second passivation layer in the reflective portion "C" **124** by depositing and patterning a reflective conductive metal, such as aluminum (Al) and silver (Ag). The reflective electrode **132** is connected to both the drain electrode **114** and

the transparent electrode **122**. Since the reflective electrode **132** has an unevenness corresponding to the unevenness "F" of the second passivation layer **124**, high reflectance is obtained and mirror reflection is prevented. A ratio of the transmissive portion "A" to the reflective portion "C" can be changed by adjusting a space between the first branch line **118a** and the second branch line **118b**.

FIG. 7 is a schematic cross-sectional view of a liquid crystal display device according to a second embodiment of the present invention. As shown in FIG. 7, a first substrate **300** and a second substrate **400** are spaced apart from each other. A thin film transistor (TFT) "T" including a gate electrode **302**, an active layer **310**, a source electrode **314** and a drain electrode **316** is formed on an inner surface of the first substrate **300**. A gate line (not shown) connected to the gate electrode **302** crosses a data line **318** connected to the source electrode **314** to define a first pixel region "P1" and a second pixel region "P2." The data line **318** is divided into a first branch line **318a** and a second branch line **318b** at one end of the first substrate **300**. A width of the first branch line **318a** can be the same as a width of the second branch line **318b**.

A first passivation layer **320** is formed on an entire surface of the first substrate **300** including the TFT "T" and the data line **318**. A transparent electrode **322** is formed on the first passivation layer **320** corresponding to a space "D" between the first branch line **318a** and second branch line **318b**. A second passivation layer **324** is formed on the transparent electrode **322** and a reflective electrode **332** connected to the drain electrode **316** and the transparent electrode **322** is formed on the second passivation layer **324**. The reflective electrode **332** can have an unevenness to increase brightness along a slant angle and to prevent mirror reflection. The unevenness can be indirectly obtained by forming the second passivation layer **324** to have an uneven portion "F" at a surface thereof.

The first branch line **318a** and second branch line **318b** are formed under the reflective electrodes **332** of the first pixel region "P1" and the second pixel region "P2," respectively. Since the transparent electrode **322** connected to the drain electrode **316** is formed in the space "D" between the first branch line **318a** and second branch line **318b**, light from a backlight unit (not shown) under the first substrate **300** passes through the space "D" and is emitted to the exterior. Accordingly, the space "D" and the reflective electrode **332** corresponds to a transmissive portion "A" and a reflective portion "C," respectively. Each pixel region "P1" and "P2" includes the transmissive portion "A" and the reflective portion "C."

A color filter layer **336**, including red sub-color filter **336a**, green sub-color filter **336b** and blue sub-color filter **336c**, is formed on the reflective electrode **332** and the second passivation layer **324** corresponding to the transmissive portion "A." One of the red sub-color filter **336a**, green sub-color filter **336b** and blue sub-color filter **336c** corresponds to one of the pixel regions "P1" and "P2." Since the color filter layer **336** is formed on the first substrate **300**, an alignment margin for attachment errors is not necessary. Accordingly, aperture ratio is further improved. A transparent common electrode **402** is formed on an inner surface of the second substrate **400**. A liquid crystal layer **390** is formed between the color filter layer **336** and the common electrode **402**.

FIG. 8 is a cross-sectional view of a liquid crystal display device according to a third embodiment of the present invention. To obtain an equal color property in the transmissive portion and the reflective portion, a liquid crystal display device including a color filter layer of a dual thickness can be used. As shown in FIG. 8, a first substrate **300** and a second substrates **400** are spaced apart from each other. A thin film

transistor (TFT) "T," including a gate electrode **302**, an active layer **310**, a source electrode **314** and a drain electrode **316**, is formed on an inner surface of the first substrate **300**. A gate line (not shown) connected to the gate electrode **302** crosses a data line **318** connected to the source electrode **314** to define a first pixel region "P1" and a second pixel region "P2." The data line **318** is divided into a first branch line **318a** and a second branch line **318b** at one end of the first substrate **300**. A width of the first branch line **318a** can be the same as a width of the second branch line **318b**.

A first passivation layer **320** is formed on an entire surface of the first substrate **300** including the TFT "T" and the data line **318**, and a transparent electrode **322** is formed on the first passivation layer **320** corresponding to a space "D" between the first and second branch lines **318a** and **318b**. A second passivation layer **324** is formed on the transparent electrode **322** and a reflective electrode **332** connected to the drain electrode **316** and the transparent electrode **322** is formed on the second passivation layer **324**. The reflective electrode **332** can have an unevenness to increase brightness along a slant angle and to prevent mirror reflection. The unevenness can be indirectly obtained by forming the second passivation layer **324** to have an uneven portion "F" at a surface thereof.

The first branch line **318a** and the second branch line **318b** are formed under the reflective electrodes **332** of the first pixel region "P1" and the second pixel region "P2," respectively. Since the transparent electrode **322** connected to the drain electrode **316** is formed in the space "D" between the first branch line **318a** and the second branch line **318b**, light from a backlight unit (not shown) under the first substrate **300** passes through the space "D" and is emitted to exterior. Accordingly, the space "D" and the reflective electrode **332** corresponds to a transmissive portion "A" and a reflective portion "C," respectively. Each pixel region "P1" and "P2" includes the transmissive portion "A" and the reflective portion "C."

The second passivation layer **324** has a groove **326** corresponding to the transmissive portion "A." A color filter layer **336**, including red sub-color filter **336a**, green sub-color filter **336b** and blue sub-color filter, is formed on the reflective electrode **332** and the second passivation layer **324** corresponding to the transmissive portion "A." One of the red sub-color filter **336a**, green sub-color filter **336b** and blue sub-color filter **336c** corresponds to one of the pixel regions "P1" and "P2." The color filter layer **336** fills the groove **326** of the second passivation layer **324**, thereby a first thickness "2t" of the color filter layer **336** in the transmissive portion "A" is substantially twice as great as a second thickness "t" of the color filter layer **336** in the reflective portion "C." Therefore, a uniform color purity property can be obtained in the transmissive portion "A" and the reflective portion "C," and an LCD device having a high display quality is obtained. A transparent common electrode **402** is formed on an inner surface of the second substrate **400**. A liquid crystal layer **390** is formed between the color filter layer **336** and the common electrode **402**.

In an LCD device according to the second and third embodiments of the present invention, since the data line **318** is formed under the reflective electrodes **332** in the reflective portion "C" of the first and second pixel regions "P1" and "P2," a black matrix corresponding to the data line **318** can be omitted. Moreover, since the transparent electrode **322** connected to the drain electrode **316** is formed in a space "D" between the first branch line **318a** and the second branch line **318b**, a black matrix corresponding to the space "D" can also be omitted. In addition, since the space between the first branch line **318a** and the second branch line **318b** is used as

the transmissive portion "A," aperture ratio and brightness are further improved. Moreover, since the color filter layer **336** is formed on the first substrate **300**, an alignment margin for accommodating attachment errors is not necessary and aperture ratio is further improved. In an LCD device according to the third embodiment of the present invention, since the color filter layer has a dual thickness such that a first thickness in the transmissive portion "A" is substantially twice as great as a second thickness in the reflective portion "C," a uniform color purity property resulting in an LCD device having a high display quality can be obtained in the transmissive portion "A" and the reflective portion "C."

In an LCD device according to the present invention, a data line is divided into first and second branch lines, and the first and second branch lines are disposed in reflective portions of adjacent pixel regions. As a result, a black matrix corresponding to the data line can be omitted by utilizing a space between the first and second branch lines as a transmissive portion. Accordingly, aperture ratio and brightness are improved. Moreover, when the LCD device includes a groove in the transmissive portion, a liquid crystal layer can have a first thickness (i.e., a first cell gap) in the transmissive portion and a second thickness (i.e., a second cell gap) in the reflective portion such that the first thickness is substantially twice as great as the second thickness. In an LCD device having a dual cell gap structure, since a uniform optical property is obtained in the transmissive portion and the reflective portion, a high display quality is obtained. In addition, since a color filter layer is formed on an array substrate, alignment margin for accommodating attachment errors is not necessary and aperture ratio is further improved. Furthermore, an LCD device having uniform color property in the transmissive portion and the reflective portion and high display quality can be obtained by forming a color filter layer such that a first thickness of the color filter layer in the transmissive portion is substantially twice as great as a second thickness of the color filter layer in the reflective portion.

It will be apparent to those skilled in the art that various modifications and variations can be made in the liquid crystal display device and method of fabricating the same of the present invention without departing from the spirit or scope of the invention. Thus, it is intended that the present invention cover the modifications and variations of this invention provided they come within the scope of the appended claims and their equivalents.

What is claimed is:

1. A liquid crystal display device, comprising:
 - first and second substrates spaced apart from each other;
 - a gate line on the first substrate;
 - a data line crossing the gate line to define a pixel region including a transmissive portion and a reflective portion, the data line being divided into first and second branch lines, the first and second branch lines being spaced apart from each other and disposed in the reflective portion of the adjacent pixel regions, respectively;
 - a thin film transistor connected to the gate line and the data line;
 - a reflective electrode corresponding to the reflective portion and covering the first and second branch lines;
 - a transparent electrode corresponding to the transmissive portion and connected to the reflective electrode;
 - a color filter layer on the second substrate;
 - a common electrode on the color filter layer; and
 - a liquid crystal layer between the reflective electrode and the common electrode.
2. A liquid crystal display device, comprising:
 - first and second substrates spaced apart from each other;

11

a gate line on the first substrate;
 a data line crossing the gate line to define a pixel region including a transmissive portion and a reflective portion, the data line being divided into first and second branch lines, the first and second branch lines being spaced apart from each other and disposed in the reflective portion of the adjacent pixel regions, respectively;
 a thin film transistor connected to the gate line and the data line;
 a reflective electrode corresponding to the reflective portion and covering the first and second branch lines;
 a transparent electrode corresponding to the transmissive portion and connected to the reflective electrode;
 a color filter layer on the reflective electrode;
 a common electrode on the second substrate; and
 a liquid crystal layer between the color filter layer and the common electrode.

3. The device according to claim 2, further comprising a passivation layer between the transparent electrode and the reflective electrode, the passivation layer including a groove corresponding to the transmissive portion.

4. The device according to claim 3, wherein the liquid crystal layer has a first thickness in the transmissive portion and a second thickness in the reflective portion, the first thickness being substantially twice as great as the second thickness.

5. The device according to claim 4, wherein the color filter layer has a third thickness in the transmissive portion and a fourth thickness in the reflective portion, the third thickness being substantially twice as great as the fourth thickness.

6. A fabricating method of a liquid crystal display device, comprising:

forming a gate line on a first substrate;
 forming a data line crossing the gate line to define a pixel region including a transmissive portion and a reflective portion, the data line being divided into first and second branch lines, the first and second branch lines being spaced apart from each other and disposed in the reflective portion of the adjacent pixel regions, respectively;
 forming a thin film transistor connected to the gate line and the data line;
 forming a reflective electrode corresponding to the reflective portion and covering the first and second branch lines;

12

forming a transparent electrode corresponding to the transmissive portion and connected to the reflective electrode;

forming a color filter layer on a second substrate;
 forming a common electrode on the color filter layer;
 attaching the first and second substrates such that the reflective electrode faces the common electrode; and
 forming a liquid crystal layer between the reflective electrode and the color filter layer.

7. A fabricating method of a liquid crystal display device, comprising:

forming a gate line on a first substrate;
 forming a data line crossing the gate line to define a pixel region including a transmissive portion and a reflective portion, the data line being divided into first and second branch lines, the first and second branch lines being spaced apart from each other and disposed in the reflective portion of the adjacent pixel regions, respectively;
 forming a thin film transistor connected to the gate line and the data line;

forming a reflective electrode corresponding to the reflective portion and covering the first and second branch lines;

forming a transparent electrode corresponding to the transmissive portion and connected to the reflective electrode;

forming a color filter layer on the reflective electrode;
 forming a common electrode on a second substrate;
 attaching the first and second substrates such that the color filter layer faces the common electrode; and
 forming a liquid crystal layer between the color filter layer and the common electrode.

8. The method according to claim 7, further comprising forming a passivation layer between the transparent electrode and the reflective electrode, the passivation layer including a groove corresponding to the transmissive portion.

9. The method according to claim 8, wherein the liquid crystal layer has a first thickness in the transmissive portion and a second thickness in the reflective portion, the first thickness being substantially twice as great as the second thickness.

10. The device according to claim 9, wherein the color filter layer has a third thickness in the transmissive portion and a fourth thickness in the reflective portion, the third thickness being substantially twice as great as the fourth thickness.

* * * * *

专利名称(译)	液晶显示装置及其制造方法		
公开(公告)号	US7567329	公开(公告)日	2009-07-28
申请号	US11/446399	申请日	2006-06-05
[标]申请(专利权)人(译)	乐金显示有限公司		
申请(专利权)人(译)	LG.飞利浦液晶CO., LTD.		
当前申请(专利权)人(译)	LG DISPLAY CO., LTD.		
[标]发明人	JEONG WOO NAM JIN HYUN SUK KANG WON SEOK		
发明人	JEONG, WOO-NAM JIN, HYUN-SUK KANG, WON-SEOK		
IPC分类号	G02F1/1343 G02F1/1335 G02F1/1368 H01L29/786		
CPC分类号	G02F1/1343 G02F1/133512		
代理机构(译)	摩根路易斯律师事务所		
审查员(译)	NGUYEN, 龚便T.		
优先权	1020030029824 2003-05-12 KR		
其他公开文献	US20060221279A1		
外部链接	Espacenet USPTO		

摘要(译)

一种液晶显示装置用阵列基板，包括：基板；基板上的栅极线；穿过栅极线的数据线以限定包括透射部分和反射部分的像素区域，数据线被分成第一和第二分支线，第一和第二分支线彼此间隔开并设置在反射中相邻像素区域的一部分；薄膜晶体管连接到栅极线和数据线；反射电极，对应于反射部分并覆盖第一和第二分支线；透明电极对应于透射部分并连接到反射电极。

