



US 20070115422A1

(19) **United States**

(12) **Patent Application Publication**

Lee et al.

(10) **Pub. No.: US 2007/0115422 A1**

(43) **Pub. Date: May 24, 2007**

(54) **LIQUID CRYSTAL DISPLAY DEVICE AND METHOD OF FABRICATING THE SAME**

(30) **Foreign Application Priority Data**

Jun. 27, 2003 (KR)..... 2003-0042729

(76) Inventors: **Chang- Hoon Lee**, Gyeongsangbuk-do (KR); **Il-Man Choi**, Dae-gu (KR)

Publication Classification

Correspondence Address:
MCKENNA LONG & ALDRIDGE LLP
1900 K STREET, NW
WASHINGTON, DC 20006 (US)

(51) **Int. Cl.**
G02F 1/1339 (2006.01)
(52) **U.S. Cl.** 349/156

(57) **ABSTRACT**

A color filter substrate for a liquid crystal display device includes a substrate having a plurality of pixel regions, a black matrix array having a lattice configuration on the substrate, the black matrix array corresponding to boundary regions between adjacent ones of the pixel regions, a plurality of color filter layers, each corresponding to one of the pixel regions, and a column spacer array having a lattice configuration, the column spacer array corresponding to the black matrix array.

(21) Appl. No.: **11/652,686**

(22) Filed: **Jan. 12, 2007**

Related U.S. Application Data

(62) Division of application No. 10/872,541, filed on Jun. 22, 2004, now Pat. No. 7,184,118.

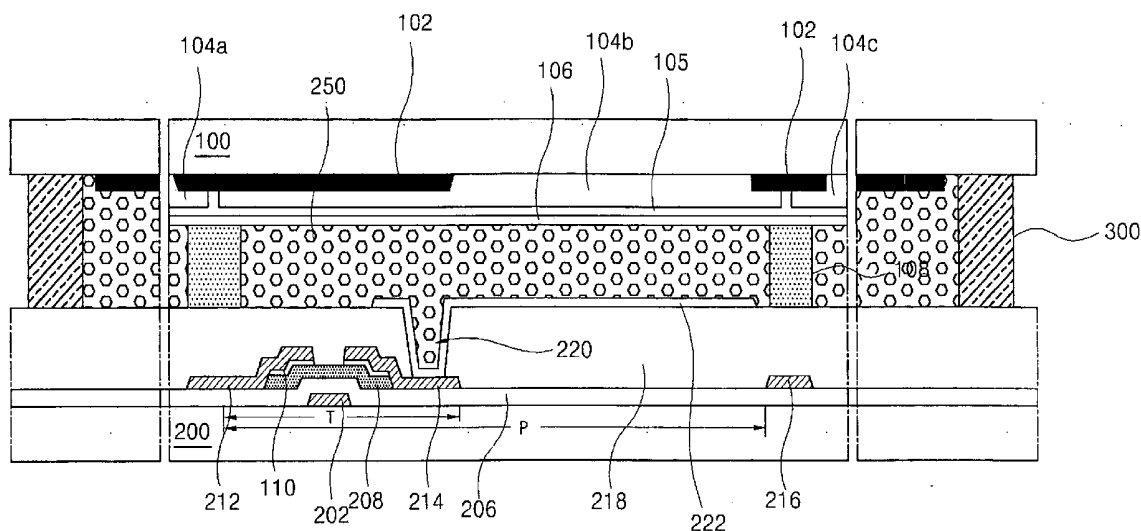

FIG. 1
RELATED ART

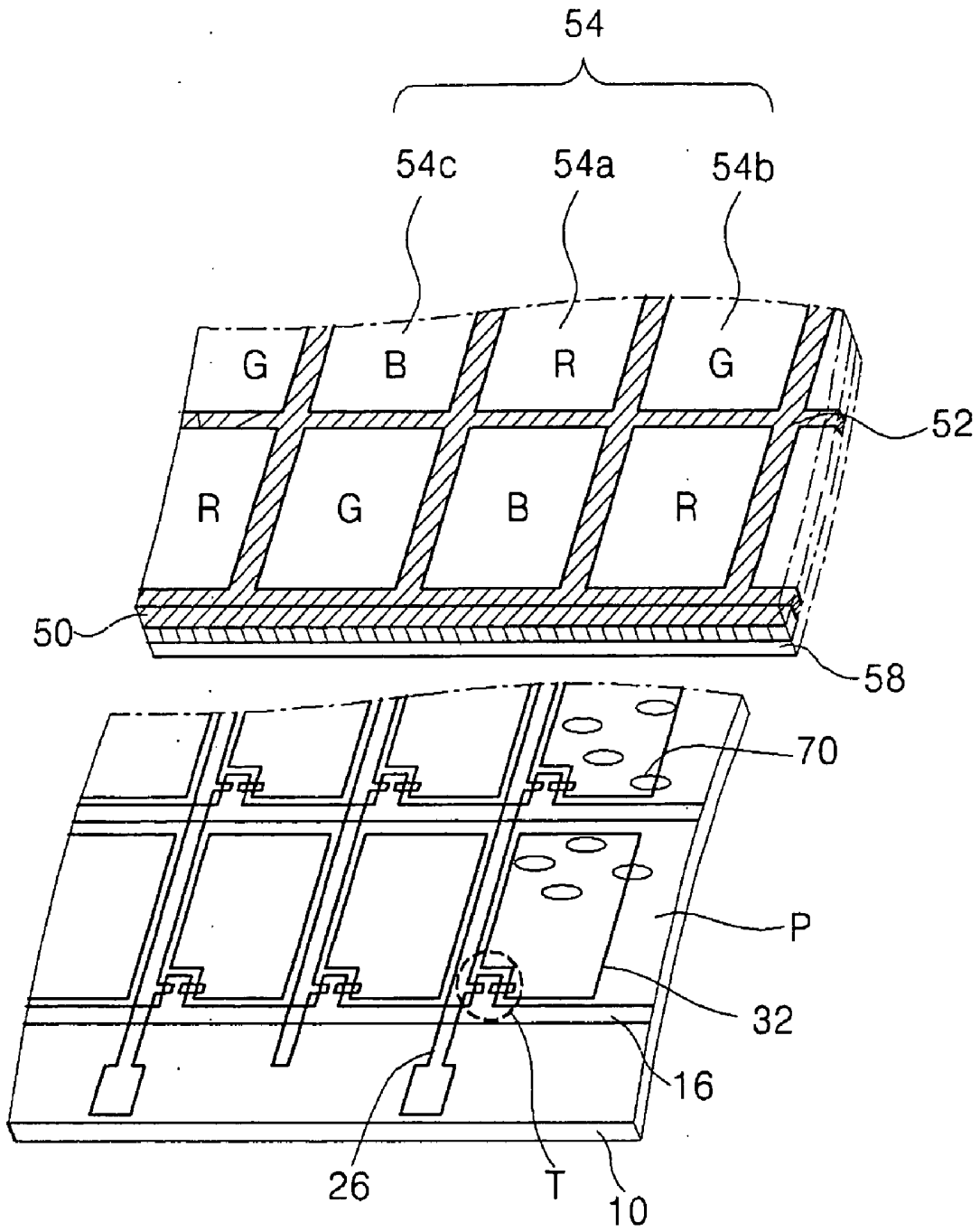

FIG. 2 RELATED ART

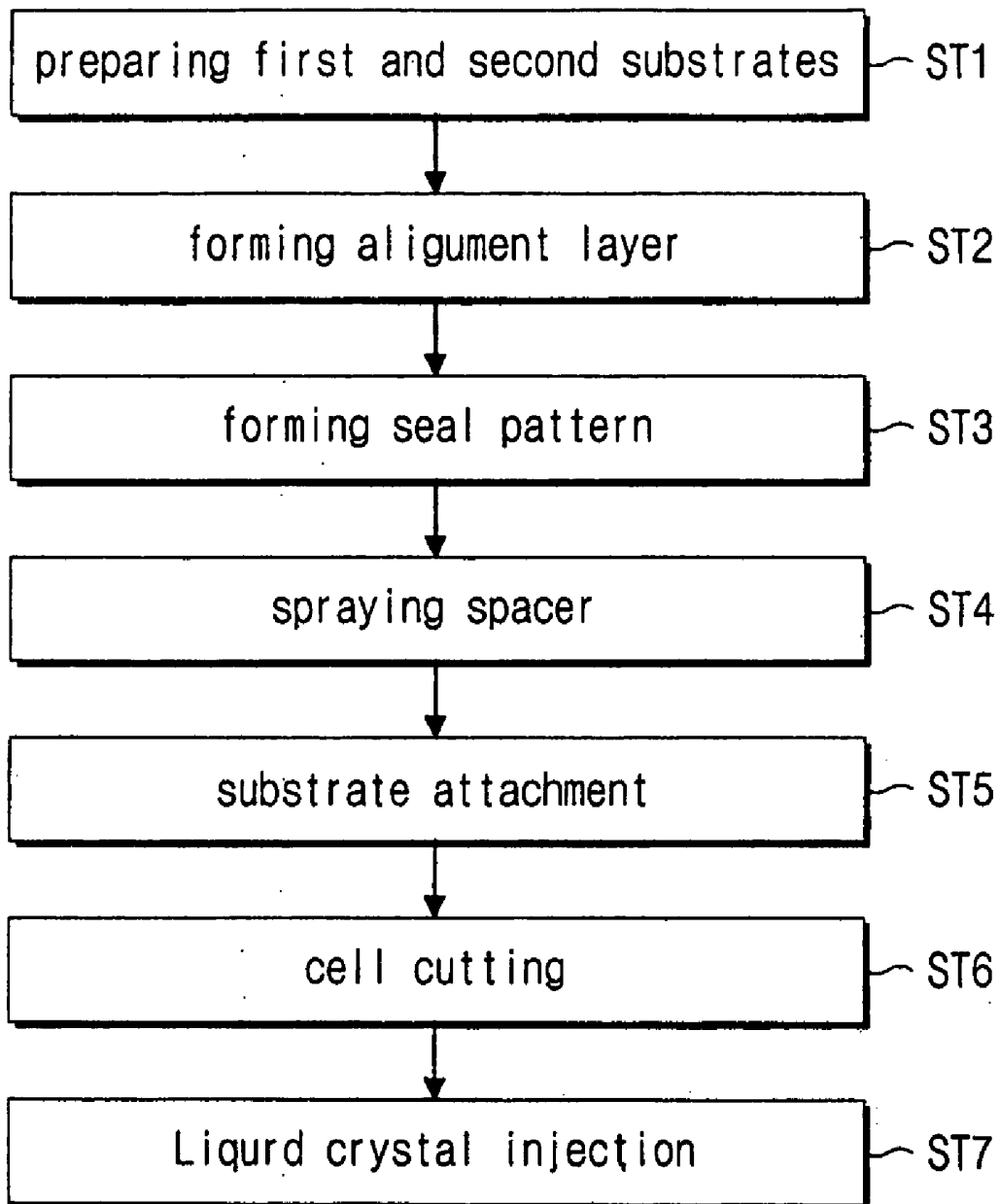

FIG. 3
RELATED ART

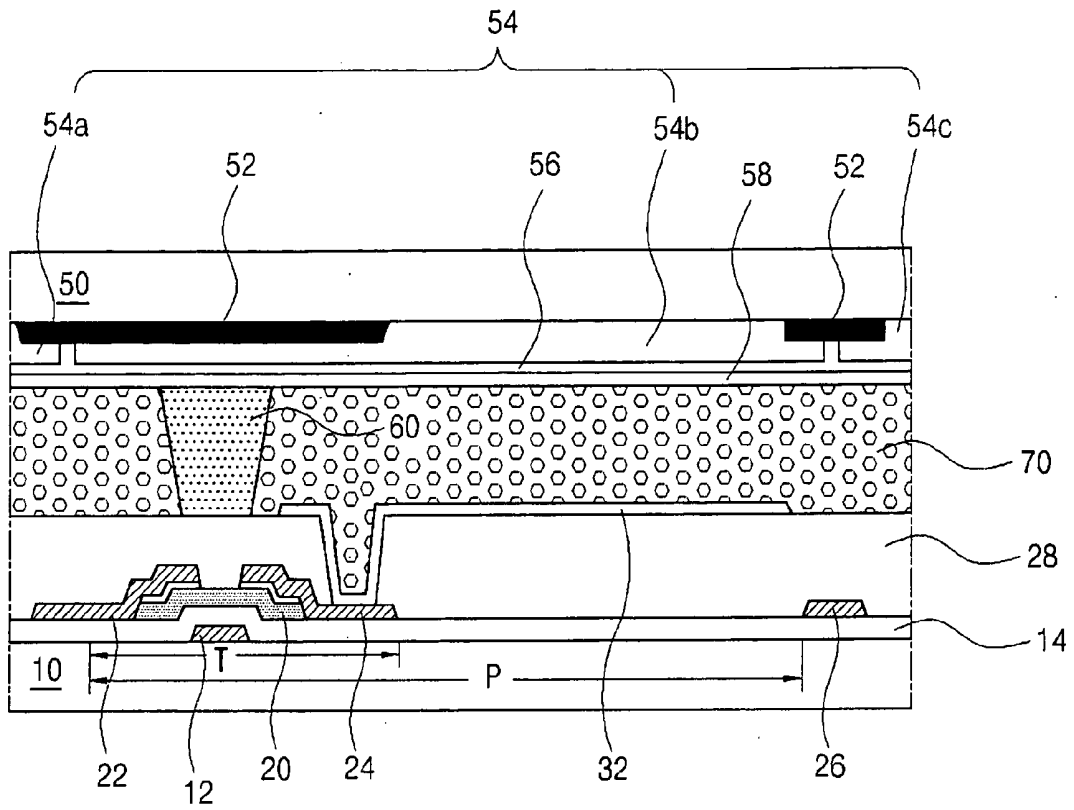

FIG. 4
RELATED ART

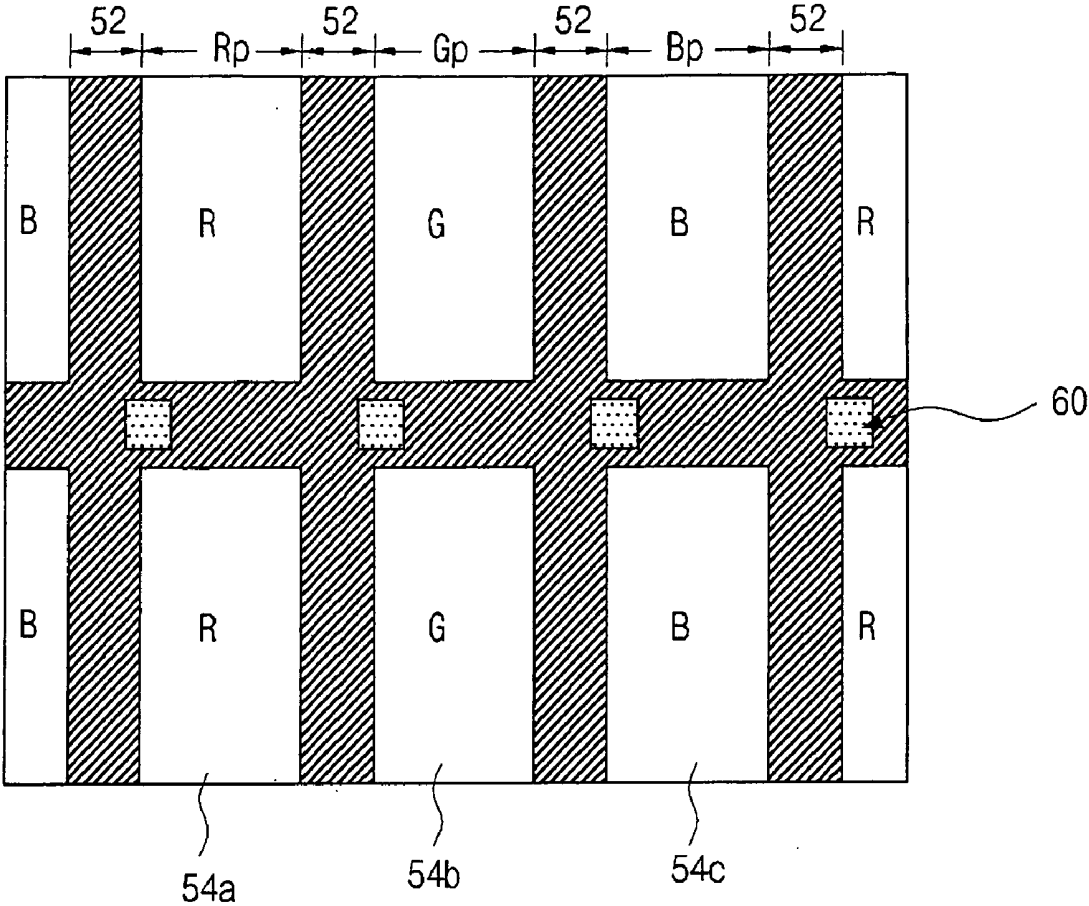

FIG. 5

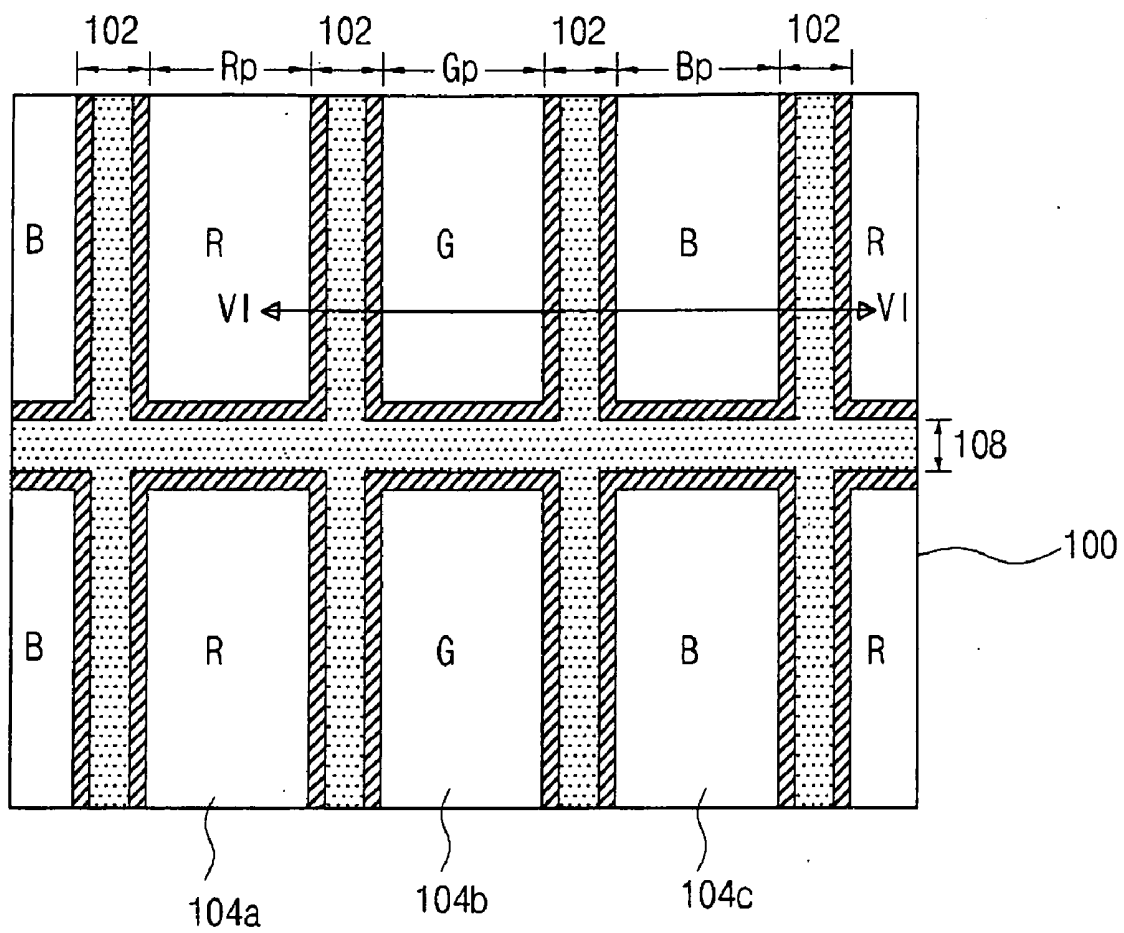

FIG. 6A

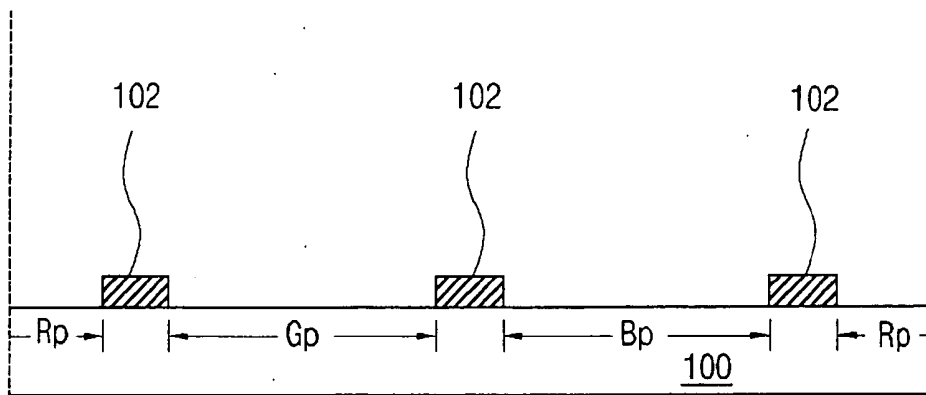

FIG. 6B

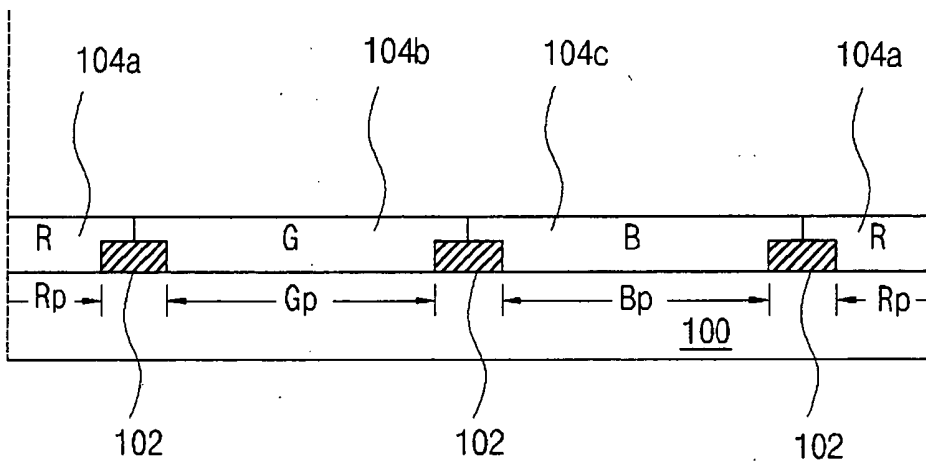
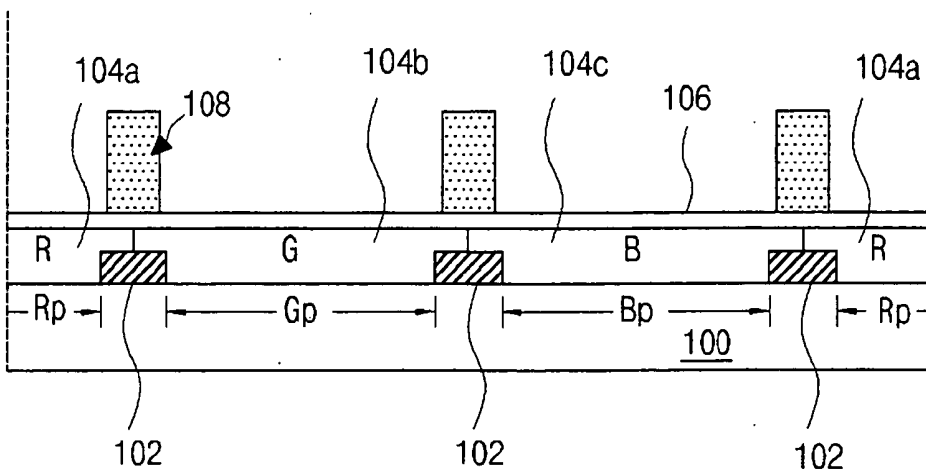

FIG. 6C



LIQUID CRYSTAL DISPLAY DEVICE AND METHOD OF FABRICATING THE SAME

[0001] The present invention claims the benefit of Korean Patent Application No. 2003-0042729 filed in Korea on Jun. 27, 2003, which is hereby incorporated by reference.

BACKGROUND OF THE INVENTION

[0002] 1. Field of the Invention

[0003] The present invention relates to a display device and a method of fabricating a display device, and more particularly, to a liquid crystal display (LCD) device and a method of fabricating an LCD device.

[0004] 2. Discussion of the Related Art

[0005] In general, an LCD device includes two substrates that are spaced apart and facing each other, wherein a liquid crystal layer is interposed between the two substrates. Each of the substrates includes an electrode, wherein the electrodes of each substrate also face each other. Accordingly, when a voltage is supplied to each of the electrodes, an electric field is induced to the liquid crystal layer between the electrodes. Thus, alignment of liquid crystal molecules of the liquid crystal layer are changed by varying the intensity or direction of the electric field, thereby varying light transmissivity of the liquid crystal layer and displaying an image.

[0006] FIG. 1 is a perspective view of an LCD device according to the related art. In FIG. 1, an LCD device has upper and lower substrates **50** and **10** that are spaced apart from and facing each other, and a liquid crystal layer **70** is interposed between the upper substrate **50** and the lower substrate **10**. The upper substrate **50** may commonly be referred to as a color filter substrate, and the lower substrate **10** may be commonly referred to as a TFT array substrate.

[0007] The upper substrate **50** includes a black matrix **52**, a color filter layer **54**, and a common electrode **58** disposed along an interior surface (i.e., side facing the lower substrate **10**) of the upper substrate **50**. The color filter layer **54** corresponds to openings formed within the black matrix **52**, and includes three sub-color filters of red (R) **54a**, green (G) **54b**, and blue (B) **54c**. In addition, the common electrode **58** is formed on the color filter layer **54** and is formed of a transparent material.

[0008] In FIG. 1, at least one gate line **16** and at least one data line **26** are formed on an interior surface (i.e., side facing the upper substrate **50**) of the lower substrate **10**, wherein the gate line **16** and the data line **26** cross each other to define a pixel region P. A switching element, such as a thin film transistor (TFT) T, is formed at the crossing point of the gate line **16** and the data line **26**, wherein the TFT T includes a gate electrode, a source electrode, and a drain electrode. A plurality of the TFTs is arranged in a matrix configuration to correspond to other crossings of gate and data lines **16** and **26**. In addition, a pixel electrode **32** is formed in the pixel region P, and is connected to the TFT T. The pixel electrode **32** corresponds to the sub-color filters **54a**, **54b**, and **54c**, and is formed of a transparent conductive material, such as indium-tin-oxide (ITO), that has a relatively high light transmissivity.

[0009] FIG. 2 is a flow chart of a fabrication process of an LCD device according to the related art. In FIG. 2, a step

ST1 includes preparation of a lower substrate having TFTs and pixel electrodes, and an upper substrate having a color filter layer and a common electrode.

[0010] Next, a step ST2 includes formation of first and second alignment layers on the pixel electrode and the common electrode, respectively. The formation of the first and second alignment layers includes coating thin polymer films, such as polyimide, on the pixel and common electrodes, and rubbing the thin polymer films. The thin polymer films must have uniform thickness, and the rubbing process must be performed uniformly along the thin polymer films. Accordingly, an initial orientation of liquid crystal molecules is determined by the rubbing process.

[0011] Then, step ST3 includes forming a seal pattern on either the lower substrate or the upper substrate, thereby providing a cell gap between the lower and upper substrates to allow for injection of liquid crystal material between the lower and upper substrates. In addition, the seal pattern prevents the injected liquid crystal material from leaking through the seal pattern. The seal pattern is commonly fabricated using a screen-printing method or a dispensing method that includes a mixture of thermosetting resin and glass fiber.

[0012] During step ST4, spacers are sprayed on one of the lower and upper substrates using a spacer spraying method to maintain a uniform gap between the lower and upper substrates. The spacer spray method can be divided into two different types, such as a wet spray method that includes spraying a mixture of alcohol and spacer material, and a dry spray method that includes spraying spacer material alone.

[0013] In FIG. 2, the seal pattern and the spacers are formed on different substrates. For example, the seal pattern may be formed on the upper substrate that has a relatively flat surface, and the spacers may be formed on the lower substrate.

[0014] During step ST5, the lower and upper substrates are aligned and are attached to each other along the seal pattern. An alignment accuracy of the substrates is determined by an alignment margin, wherein an alignment accuracy of several micrometers is required since light leakage occurs if the substrates are misaligned beyond the alignment margin.

[0015] During step ST6, the attached substrates are divided into unit cells using a cell cutting process. The cell cutting process includes a scribing process that forms scribe lines on a surface of the substrate using a diamond pen or a cutting wheel of tungsten carbide, wherein a hardness of the diamond pen or cutting wheel is higher than a hardness of the substrate, which is formed of glass. Then, a breaking process is performed to divide the unit cells by applying a force.

[0016] During step ST7, a liquid crystal material is injected between two substrates of each individual unit cells using a vacuum injection process, wherein each unit cell has an area of several square centimeters and a cell gap of several micrometers. The vacuum injection process makes use of a pressure difference between an interior of the unit cell and an exterior of the unit cell.

[0017] Then, after completing the vacuum injection process, the injection hole is sealed to prevent leakage of the

liquid crystal material. In general, an ultraviolet (UV) curable resin is injected into the injection hole using a dispenser, and ultraviolet light is irradiated onto the resin to harden the resin and seal the injection hole. Next, polarization films are attached onto outer surfaces of the unit cell, and a driving circuit is connected to the unit cell using an attachment process.

[0018] During the above processes, special standardized spacers are used as the spacers. However, there are many limitations in spraying the spacers. In addition, it is difficult to obtain a uniform cell gap for large-sized substrates. Thus, patterned spacers have been developed, wherein the patterned spacers may be formed on the upper substrate (i.e., color filter substrate) and/or the lower substrate (i.e., TFT array substrate). If the patterned spacers are formed on the lower substrate, then the patterned spacers are disposed over array lines of the TFT array.

[0019] FIG. 3 is a schematic cross sectional view of an LCD device according to the related art. In FIG. 3, an LCD device includes a first substrate 10, a second substrate 50, and a liquid crystal layer 70 interposed therebetween. In addition, a pixel region P is defined on the first substrate 10 by crossing a gate line 16 (in FIG. 1) and a data line 26, wherein a TFT T and a pixel electrode 32 are formed within the pixel region P. The thin film transistor T includes a gate electrode 12 that is connected to the gate line 16, a semiconductor layer 20 that is disposed over the gate electrode 12, a source electrode 22 that is connected to the data line 26, and a drain electrode 22 that is spaced apart from the source electrode 22 over the semiconductor layer 20.

[0020] The first substrate includes a first insulating layer 14 formed between the gate line 16 (in FIG. 1) and the data line 26, and a second insulating layer 28 formed between the TFT T and the pixel electrode 32. The second substrate 50 includes a black matrix 52 formed on an inner surface of the second substrate 50 facing the first substrate 10, wherein the black matrix 52 corresponds to the TFT T, and also corresponds to the gate line 16 (in FIG. 1) and the data line 26. The black matrix 52 corresponding to the gate line 16 (in FIG. 1) and the data line 26 has a size such that a space between the gate and data lines 16 and 26 and the pixel electrode 32 is sufficiently covered.

[0021] The second substrate 50 further includes a color filter layer 54 formed on the black matrix 52, wherein the color filter layer 54 includes three sub color filters of red 54a, green 54b, and blue 54c that correspond to one pixel region P. In addition, an overcoat layer 56 and a transparent common electrode 58 are sequentially formed along an entire surface of the second substrate 50 including the color filter layer 54.

[0022] In FIG. 3, a column spacer 60 is formed over the second substrate 50 corresponding to the black matrix 52 to maintain a uniform cell gap between the array substrate 10 and the color filter substrate 50. Accordingly, a liquid crystal material forming the liquid crystal layer 70 is injected into the uniform cell gap formed between the array substrate 10 and the color filter substrate 50 including the column spacer 60.

[0023] FIG. 4 is a plan view of a color filter substrate according to the related art. In FIG. 4, a plurality of pixels Rp, Gp, and Bp are defined, and red, green, and blue sub

color filters 54a, 54b, and 54c are formed within the pixels Rp, Gp, and Bp, respectively. Then, a black matrix 52 is disposed between the pixels Rp, Gp, and Bp, and column spacers 60 are formed to correspond to the black matrix 52.

[0024] Next, the liquid crystal material may be filled using a vacuum injection method or a drop-filling method. The vacuum injection method includes filling the liquid crystal material under a vacuum condition by dipping an injection hole into a container filled with the liquid crystal material. Accordingly, since the vacuum injection method is complicated, the liquid crystal display panel may be contaminated due to contamination of the liquid crystal material. In addition, when the injection hole is sealed and cured, the liquid crystal material may be degraded due to irradiation of UV light.

[0025] The drop-filling method includes dropping predetermined amounts of liquid crystal material onto the array substrate or the color filter substrate. For example, a plurality of TFT array substrates or color filter substrates for forming a plurality of unit cells, and the liquid crystal material is dropped onto each of the unit cells within a sealant formed around each of the unit cells. Accordingly, the drop-filling method is advantageous over the vacuum injection method. However, since it is difficult to drop accurate amounts of the liquid crystal material, large amounts of the liquid crystal material may unnecessarily be dropped onto the substrates. Thus, when the LCD panel is completed, gravity may cause excessive amounts of the liquid crystal material to flow along a gravity direction, thereby resulting in the displaying of poor quality images.

SUMMARY OF THE INVENTION

[0026] Accordingly, the present invention is directed to an LCD device and a method of fabricating an LCD device that substantially obviates one or more problems due to limitations and disadvantages of the related art.

[0027] An object of the present invention is to provide an LCD device that prevents display of poor quality images.

[0028] Another object of the present invention is to provide a method of fabricating an LCD device that prevents display of poor quality images.

[0029] Another object of the present invention is to provide an LCD device that prevents gravitational flow of liquid crystal material.

[0030] Another object of the present invention is to provide a method of fabricating an LCD device that prevents gravitational flow of liquid crystal material.

[0031] Additional features and advantages of the invention will be set forth in the description which follows, and in part will be apparent from the description, or may be learned by practice of the invention. The objectives and other advantages of the invention will be realized and attained by the structure particularly pointed out in the written description and claims hereof as well as the appended drawings.

[0032] To achieve these and other advantages and in accordance with the purpose of the present invention, as embodied and broadly described, a color filter substrate for a liquid crystal display device includes a substrate having a plurality of pixel regions, a black matrix array having a

lattice configuration on the substrate, the black matrix array corresponding to boundary regions between adjacent ones of the pixel regions, a plurality of color filter layers, each corresponding to one of the pixel regions, and a column spacer array having a lattice configuration, the column spacer array corresponding to the black matrix array.

[0033] In another aspect, a method of fabricating a color filter substrate for a liquid crystal display device includes forming a black matrix array having a lattice configuration on a substrate, the black matrix array corresponding to boundary regions of adjacent ones of a plurality of pixel regions provided on the substrate, forming a plurality of color filter layers each corresponding to one of the pixel regions, and forming a column spacer array having a lattice configuration corresponding to the black matrix array.

[0034] In another aspect, a liquid crystal display device includes first and second substrates spaced apart from each other and having a plurality of pixel regions, gate and data lines disposed on the first substrate to cross each other, a thin film transistor at each crossing point of the gate and data lines, a pixel electrode connected to each thin film transistor, a black matrix array having a lattice configuration on the second substrate, the black matrix array corresponding to one of the gate and data lines, a color filter layer on the black matrix array and corresponding to each of the pixel regions, and a column spacer array having a lattice configuration on the color filter layer, the column spacer array corresponding to the black matrix array.

[0035] In another aspect, a method of fabricating a liquid crystal display device includes preparing first and second substrates having a plurality of pixel regions, forming gate and data lines crossing each other on the first substrate, forming a thin film transistor at each crossing point of the gate and data lines, forming a pixel electrode connected to each thin film transistor, forming a black matrix array having a lattice configuration on the second substrate, forming a color filter layer on the black matrix array, forming a column spacer array having a lattice configuration on the color filter layer, the column spacer array corresponding to the black matrix array, forming a common electrode on the second substrate, applying a liquid crystal material onto the first substrate, and attaching the first and second substrates together.

[0036] It is to be understood that both the foregoing general description and the following detailed description are exemplary and explanatory and are intended to provide further explanation of the invention as claimed.

BRIEF DESCRIPTION OF THE DRAWINGS

[0037] The accompanying drawings, which are included to provide a further understanding of the invention and are incorporated in and constitute a part of this specification, illustrate embodiments of the invention and together with the description serve to explain the principles of the invention. In the drawings:

[0038] FIG. 1 is a perspective view of an LCD device according to the related art;

[0039] FIG. 2 is a flow chart of a fabrication process of an LCD device according to the related art;

[0040] FIG. 3 is a schematic cross sectional view of an LCD device according to the related art;

[0041] FIG. 4 is a plan view of a color filter substrate according to the related art;

[0042] FIG. 5 is a plan view of an exemplary color filter substrate for an LCD device according to the present invention;

[0043] FIGS. 6A to 6C are cross sectional views along VI-VI of FIG. 5 showing an exemplary fabrication process of a color filter substrate according to the present invention; and

[0044] FIG. 7 is a cross sectional view of an exemplary LCD device according to the present invention.

DETAILED DESCRIPTION OF THE PREFERRED EMBODIMENTS

[0045] Reference will now be made in detail to the preferred embodiments of the present invention, examples of which are illustrated in the accompanying drawings.

[0046] FIG. 5 is a plan view of an exemplary color filter substrate for an LCD device according to the present invention. In FIG. 5, a plurality of pixels Rp, Gp, and Bp may be provided on a substrate 100, and red, green, and blue sub color filters 104a, 104b, and 104c may be formed within the pixels Rp, Gp, and Bp, respectively. In addition, a black matrix array 102 may be disposed between the pixels Rp, Gp, and Bp having a lattice configuration. Moreover, a spacer 108 may be formed on the black matrix array 102, and may also have a lattice configuration similar to the lattice configuration of the black matrix array 102. The spacer 108 may prevent liquid crystal material within the LCD device from flowing along a gravity direction when the LCD device is positioned along a vertical direction parallel, or nearly parallel to the gravity direction.

[0047] FIGS. 6A to 6C are cross sectional views along VI-VI of FIG. 5 showing an exemplary fabrication process of a color filter substrate according to the present invention. In FIG. 6A, a plurality of pixels Rp, Gp, and Bp may be provided on a transparent insulating substrate 100. Then, a photosensitive black resin may be formed on the substrate 100, and patterned to form a black matrix array 102 along boundary regions between the pixels Rp, Gp, and Bp. Accordingly, the black matrix array 102 may have a lattice configuration along a surface of the substrate 100.

[0048] In FIG. 6B, a color filter layer composed of three sub color filters 104a, 104b, and 104c may be formed on the substrate 100 including the black matrix array 102. Accordingly, the red, green, and blue sub color filters 104a, 104b, and 104c may correspond to the pixels Rp, Gp, and Bp, respectively. The color filter layer 104a, 104b, and 104c may be formed using a resin including pigments that transmit light of predetermined wavelengths from along the substrate 100. Then, the resin may be patterned to form the color filter layer 104a, 104b, and 104c.

[0049] In FIG. 6C, a common electrode 106 may be formed on the color filter layer 104a, 104b, and 104c, and may be disposed along an entire surface of the substrate 100. The common electrode 106 may be formed of a material selected from a transparent conductive material group including indium tin oxide (ITO) and indium zinc oxide (IZO).

[0050] Next, a transparent photosensitive resin may be formed on the common electrode **106**, and patterned to form a column spacer array **108**. The column spacer array **108** may have a lattice configuration, and may be disposed over the black matrix array **102**, as shown in FIG. 5. For example, the column spacer array **108** may have a width less than a width of the black matrix array **102**. In addition, the column spacer array **108** may be formed over boundary regions of the red, green, and blue sub color filters **104a**, **104b**, and **104c** that may correspond to the pixels Rp, Gp, and Bp, respectively.

[0051] FIG. 7 is a cross sectional view of an exemplary LCD device according to the present invention. In FIG. 7, an LCD device may include a first substrate **200**, such as a TFT array substrate, a second substrate **100**, such as a color filter substrate, and a liquid crystal layer **250** interposed therebetween. In addition, a TFT T may be formed corresponding to a pixel region P. The thin film transistor T may include a gate electrode **202**, a semiconductor layer **208** disposed over the gate electrode **202**, and source and drain electrodes **212** and **214** disposed over the semiconductor layer **208**. A passivation layer **218** may cover the TFT T, and a pixel electrode **222** may be formed on the passivation layer **218** within the pixel region P. The pixel electrode **222** may be connected to the drain electrode **214** through a contact hole **220** formed in the passivation layer **218**.

[0052] Although not shown, the pixel region P may be defined by a gate line and a data line **216** crossing each other with a gate insulating layer **206** therebetween. For example, the gate line may pass along a first side of the pixel region P and the gate line **216** may pass along a second side of the pixel region P.

[0053] In FIG. 7, a black matrix array **102** may be formed on an inner surface of the second substrate **100** facing the first substrate **200**. The black matrix array **102** may have a lattice configuration, and may correspond to positions of the TFT T, the gate line (not shown), and the data line **216**.

[0054] A color filter layer having three sub color filters of red **104a**, green **104b**, and blue **104c** may be formed on the black matrix array **102**, wherein each of the sub color filters **104a**, **104b**, and **104c** may correspond to one pixel region P. An overcoat layer **105** may be formed along an entire surface of the second substrate **100** including the sub color filters **104a**, **104b**, and **104c**. Accordingly, the overcoat layer **105** may flatten a surface of the second substrate **100** including the sub color filters **104a**, **104b**, and **104c**. In addition, a transparent common electrode **106** may be formed along an entire surface of the second substrate **100** including the overcoat layer **105**. As previously described above, the common electrode **106** may be formed of material selected from a transparent conductive material group including ITO and IZO. The pixel electrode **222** may be formed of the same material as the common electrode **106**. Alternatively, the overcoat layer **105** may be omitted.

[0055] In FIG. 7, a column spacer array **108** may be formed on the transparent common electrode **106**, wherein the column spacer array **108** may correspond to the black matrix array **102** and may have a width narrower than a width of the black matrix array **102**. In addition, a sealant **300** may be formed along peripheral portions of the TFT array substrate **200**.

[0056] According to the present invention, a liquid crystal layer **250** may be interposed between the first and second

substrates **200** and **100**. A liquid crystal material for forming the liquid crystal layer **250** may be provided on the TFT array substrate **200** using a drop-filling method after the sealant **300** has been formed. Thus, when the TFT array substrate **200** and the color filter substrate **100** are attached together, the column spacer array **108** may contact the passivation layer **218**, and the sealant **300** may contact the color filter substrate **100**.

[0057] Accordingly, after providing the liquid crystal material, the TFT array substrate **200** and the color filter substrate **100** may be attached together. Then, the liquid crystal material of the liquid crystal layer **250** may be uniformly diffused within an LCD panel of the LCD device.

[0058] According to the present invention, the column spacer array **108** may have a lattice configuration to enclose each of a plurality of pixel regions P. Thus, the liquid crystal material of the liquid crystal layer **250** may remain within the pixel regions, and may be prevented from flowing along a gravity direction. In addition, the column spacer array according to the present invention may be used in an In-Plane Switching (IPS) mode LCD device, wherein the pixel electrode and the common electrode may be formed on the same substrate.

[0059] According to the present invention, although excessive amounts of the liquid crystal material may be filled using the drop-filling method, the liquid crystal material may be prevented from flowing along a gravity direction by use of the column spacer array. Thus, a process margin for attaching the TFT array substrate and the color filter substrate may be increased since a quantity of the liquid crystal material may have an increased error range, thereby improving image quality.

[0060] It will be apparent to those skilled in the art that various modifications and variations can be made in the liquid crystal display device and method of fabricating an LCD device of the present invention without departing from the spirit or scope of the invention. Thus, it is intended that the present invention cover the modifications and variations of this invention provided they come within the scope of the appended claims and their equivalents.

1-10. (canceled)

11. A liquid crystal display device, comprising:

first and second substrates spaced apart from each other and having a plurality of pixel regions;

gate and data lines disposed on the first substrate to cross each other;

a thin film transistor at each crossing point of the gate and data lines;

a pixel electrode connected to each thin film transistor;

a black matrix array having a lattice configuration on the second substrate, the black matrix array corresponding to one of the gate and data lines;

a color filter layer on the black matrix array and corresponding to each of the pixel regions; and

a column spacer array having a lattice configuration on the color filter layer, the column spacer array corresponding to the black matrix array.

12. The device according to claim 11, wherein the column spacer array has width portions narrower than width portions of the black matrix array.

13. The device according to claim 11, further comprising a common electrode on the second substrate.

14. A method of fabricating a liquid crystal display device, comprising: preparing first and second substrates having a plurality of pixel regions;

forming gate and data lines crossing each other on the first substrate;

forming a thin film transistor at each crossing point of the gate and data lines;

forming a pixel electrode connected to each thin film transistor;

forming a black matrix array having a lattice configuration on the second substrate;

forming a color filter layer on the black matrix array;

forming a column spacer array having a lattice configuration on the color filter layer, the column spacer array corresponding to the black matrix array;

applying a liquid crystal material onto the first substrate; and

attaching the first and second substrates together.

15. The method according to claim 14, wherein the column spacer array has width portions narrower than width portions of the black matrix.

16. The method according to claim 14, wherein the black matrix array corresponds to one of the gate and data lines.

17. The method according to claim 14, wherein the color filter layer corresponds to the pixel regions.

18. The method according to claim 14, further comprising forming a common electrode on the second substrate.

* * * * *

专利名称(译)	液晶显示装置及其制造方法		
公开(公告)号	US20070115422A1	公开(公告)日	2007-05-24
申请号	US11/652686	申请日	2007-01-12
[标]申请(专利权)人(译)	LEE李昌勋 CHOI IL MAN		
申请(专利权)人(译)	李沧勋 崔IL-MAN		
当前申请(专利权)人(译)	李沧勋 崔IL-MAN		
[标]发明人	LEE CHANG HOON CHOI IL MAN		
发明人	LEE, CHANG- HOON CHOI, IL-MAN		
IPC分类号	G02F1/1339 G02F1/1333		
CPC分类号	G02F1/133377 G02F1/13394		
优先权	1020030042729 2003-06-27 KR		
其他公开文献	US7567333		
外部链接	Espacenet USPTO		

摘要(译)

一种用于液晶显示装置的滤色器基板，包括具有多个像素区域的基板，在基板上具有晶格结构的黑矩阵阵列，黑矩阵阵列对应于相邻像素区域之间的边界区域，多个每个对应于一个像素区域的滤色器层和具有晶格结构的列间隔物阵列，该列间隔物阵列对应于黑色矩阵阵列。

