



US 20060221280A1

(19) **United States**

(12) **Patent Application Publication**

Oka et al.

(10) **Pub. No.: US 2006/0221280 A1**

(43) **Pub. Date:**

Oct. 5, 2006

(54) **LIQUID CRYSTAL DISPLAY**

Publication Classification

(76) Inventors: **Shinichiro Oka**, Hitachi (JP); **Masaya Adachi**, Hitachi (JP); **Shinichi Komura**, Hitachi (JP); **Ikuo Hiyama**, Hitachinaka (JP)

(51) **Int. Cl.**
G02F 1/1335 (2006.01)

(52) **U.S. Cl.** **349/117**

Correspondence Address:
ANTONELLI, TERRY, STOUT & KRAUS, LLP
1300 NORTH SEVENTEENTH STREET
SUITE 1800
ARLINGTON, VA 22209-3873 (US)

(57) **ABSTRACT**

A liquid crystal display of a vertical alignment (VA) mode using a circular polarization plate is provided which can reduce light leak as observed along an oblique direction and achieve a high contrast ratio. The VA mode uses a liquid crystal layer of vertical alignment in an initial alignment state. A film having generally isotropic optical characteristics in an omnidirection is used as a protective film, on a liquid crystal cell side, of first and second polarization plates disposed outside the liquid crystal cell, and first and fourth retardation films have an N_z coefficient smaller than 1.

(21) Appl. No.: **11/356,188**

(22) Filed: **Feb. 17, 2006**

(30) **Foreign Application Priority Data**

Mar. 31, 2005 (JP) 2005-100483

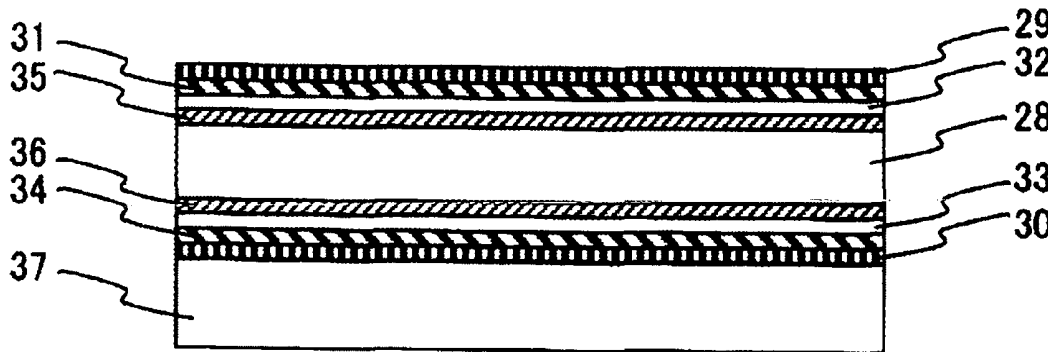

FIG.1

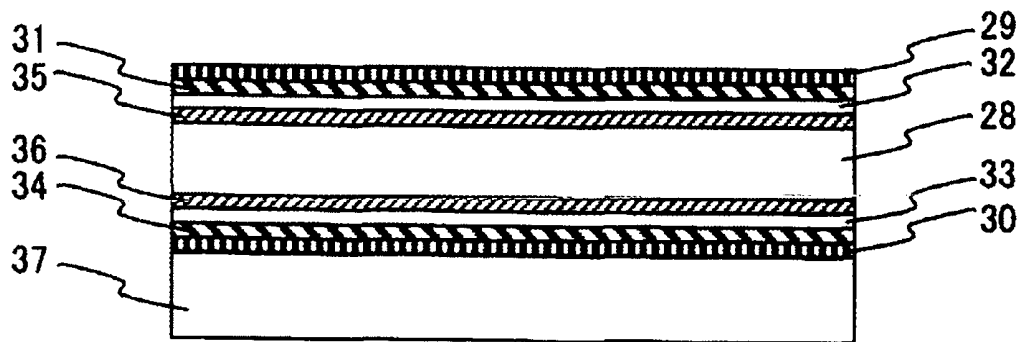

FIG.2

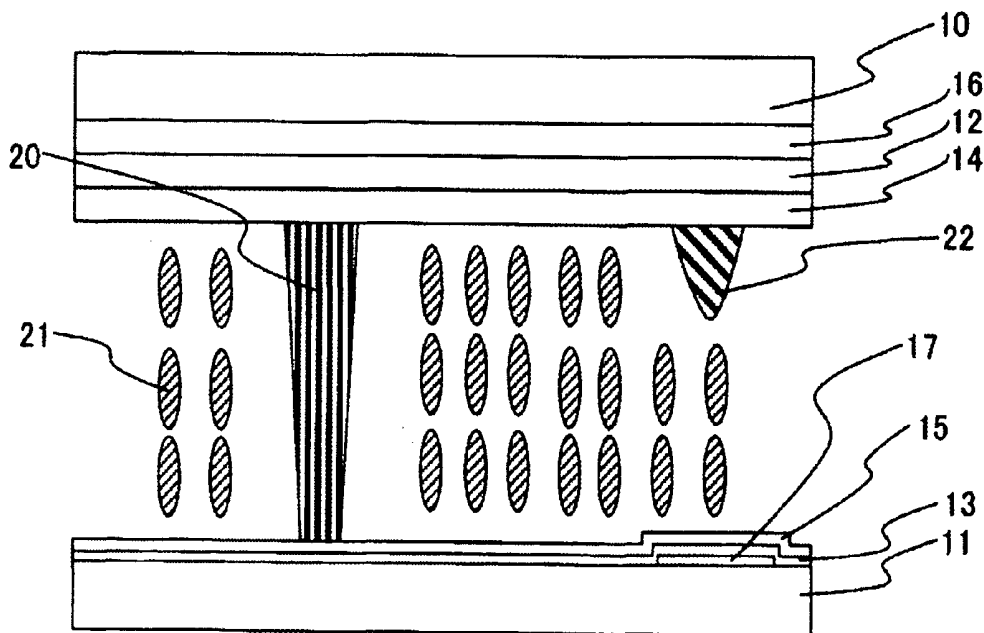

FIG.3

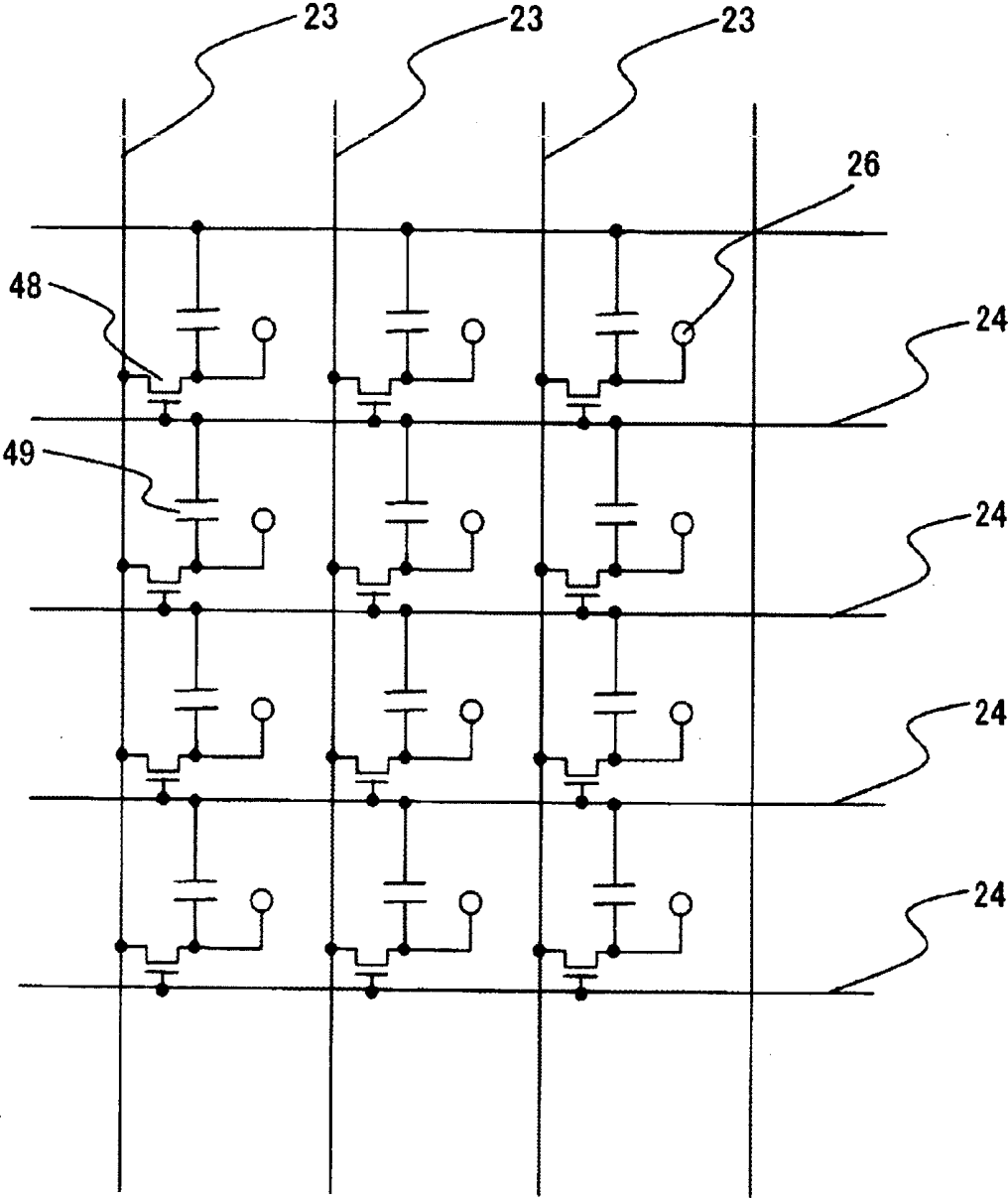

FIG.4

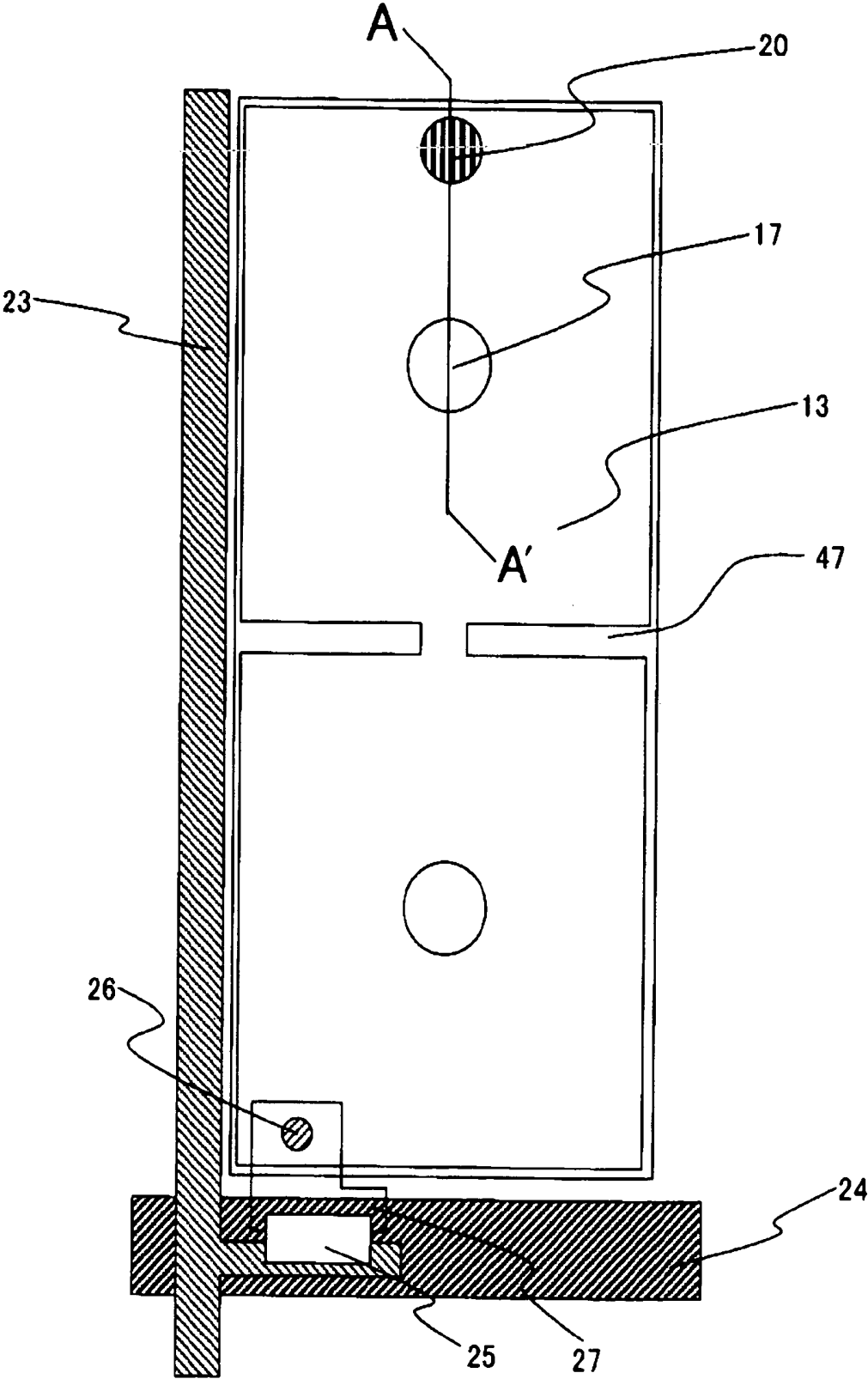

FIG.5

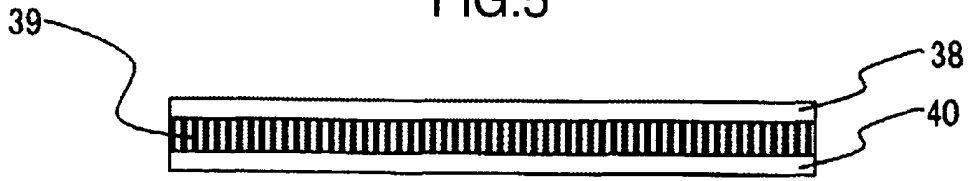

FIG.6

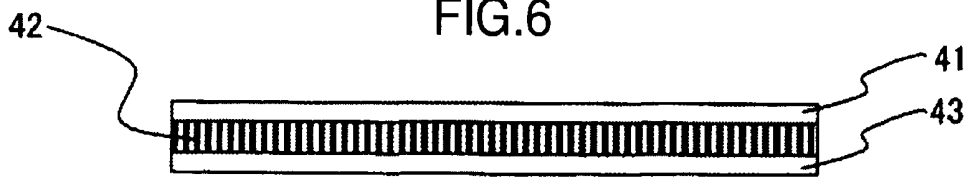

FIG.9

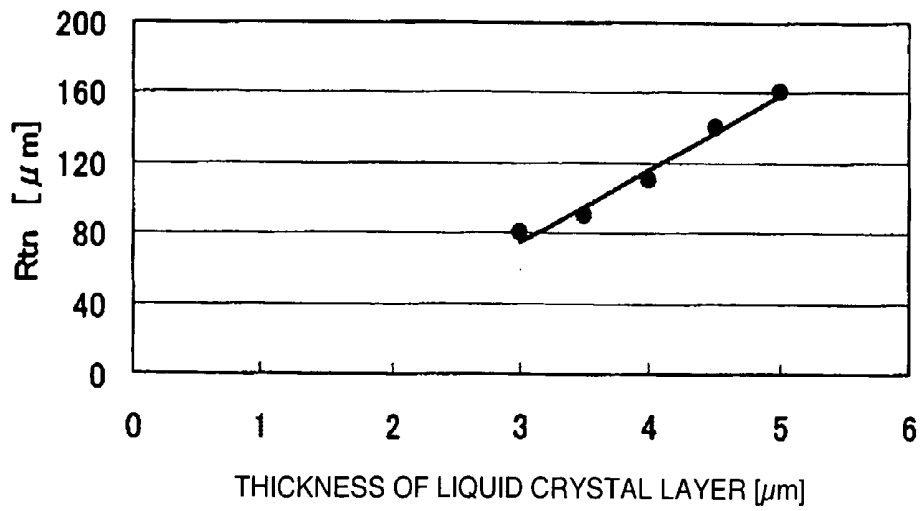

FIG. 7

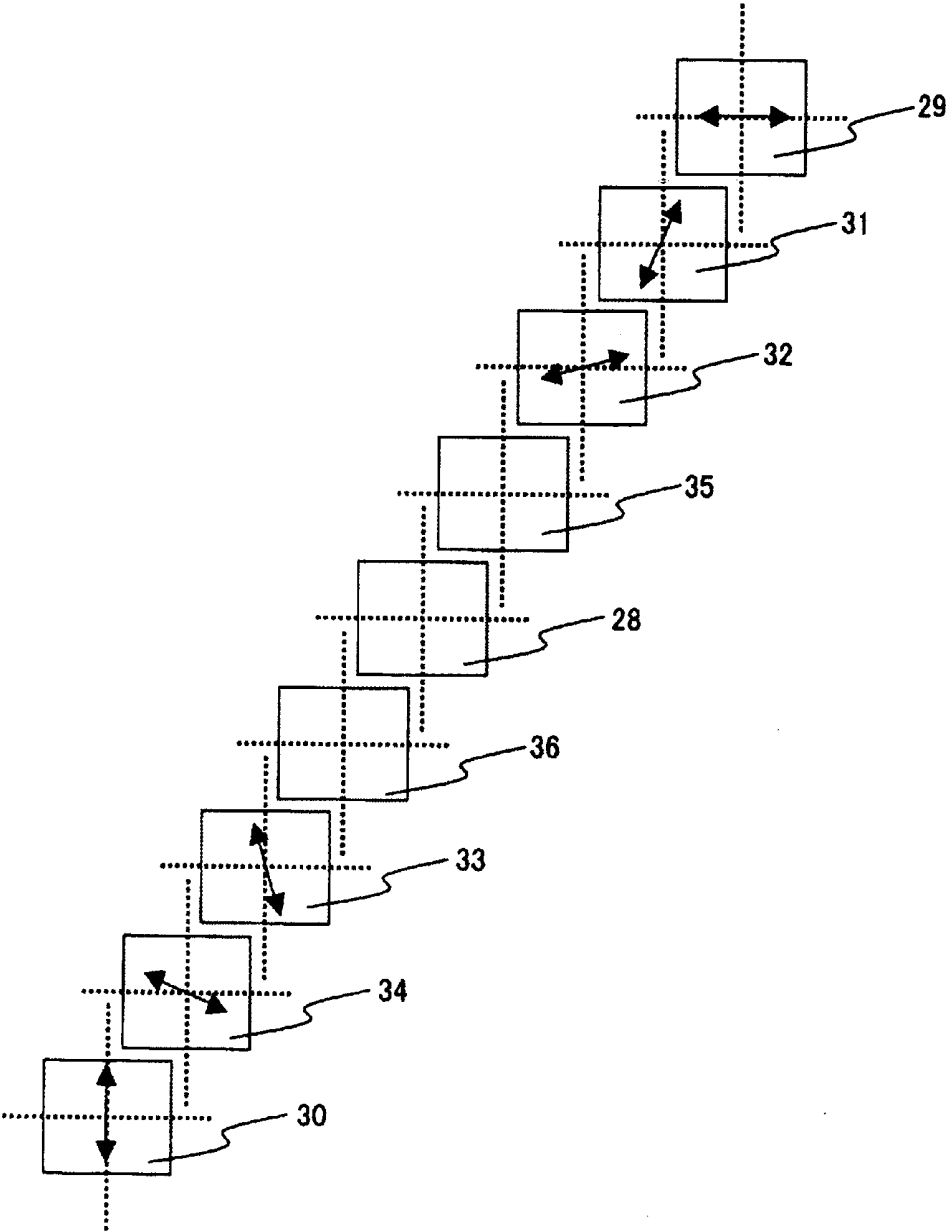

FIG.8A

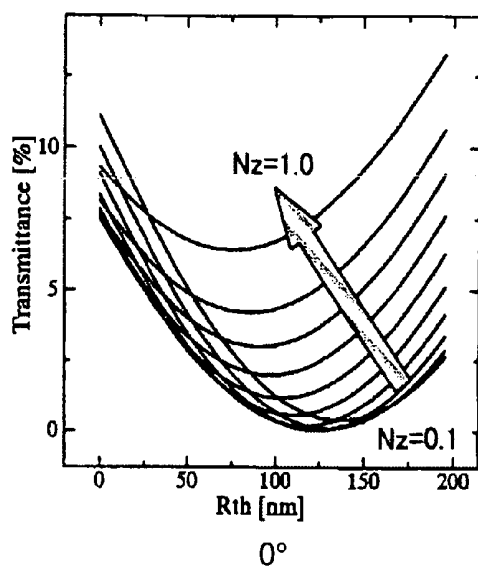

FIG.8B

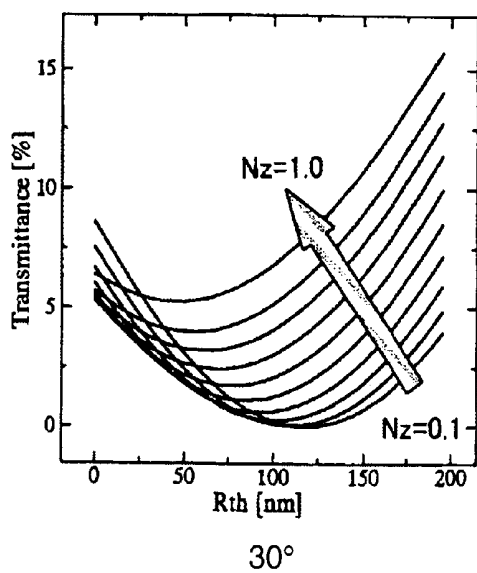

FIG.8C

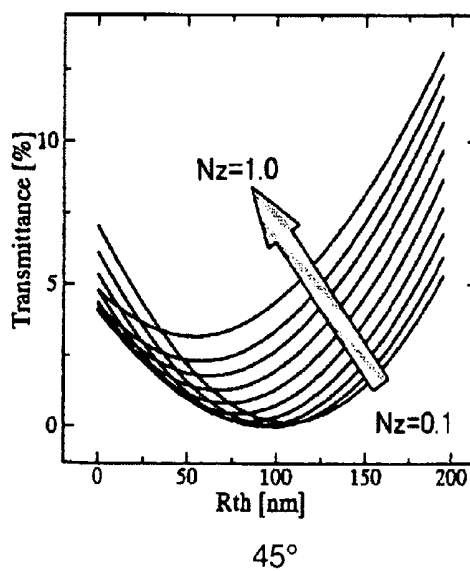

FIG.10A

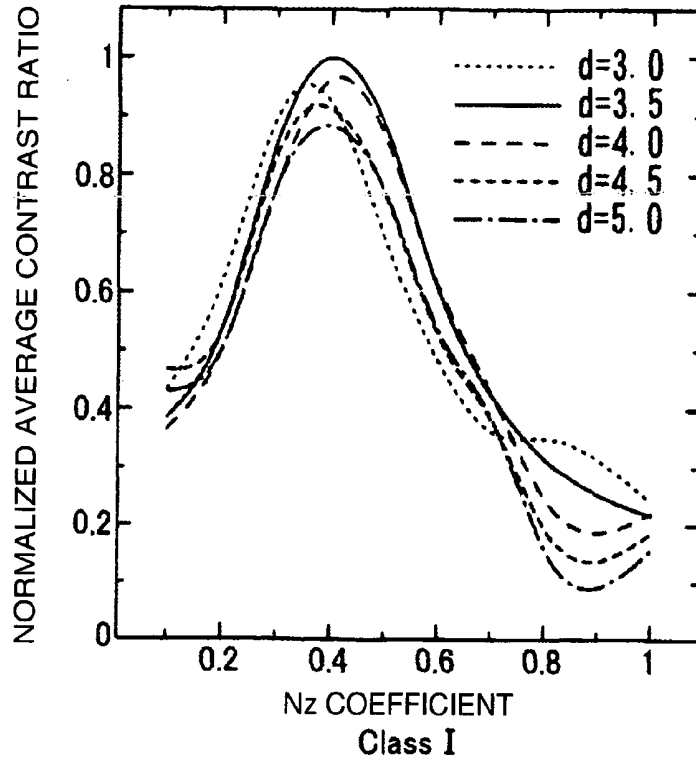

FIG.10B

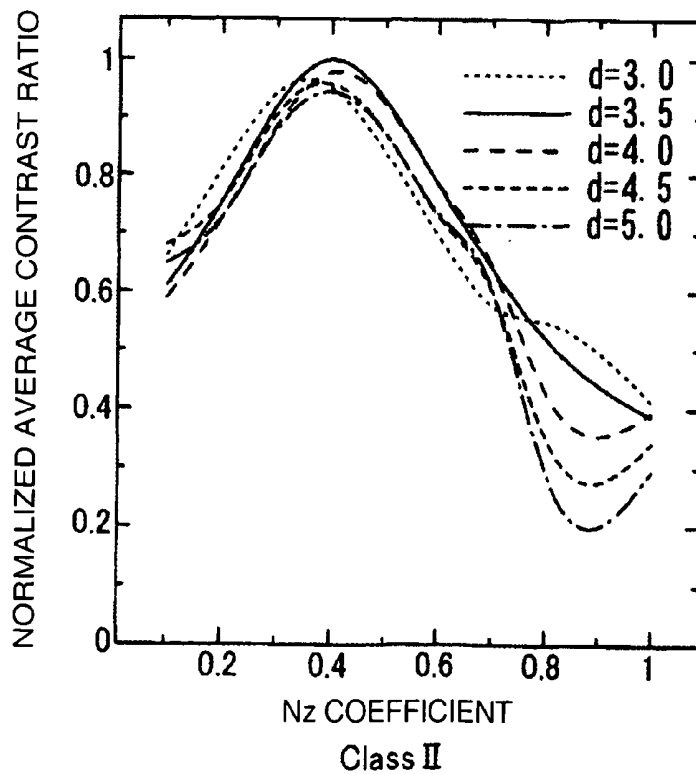

FIG.11

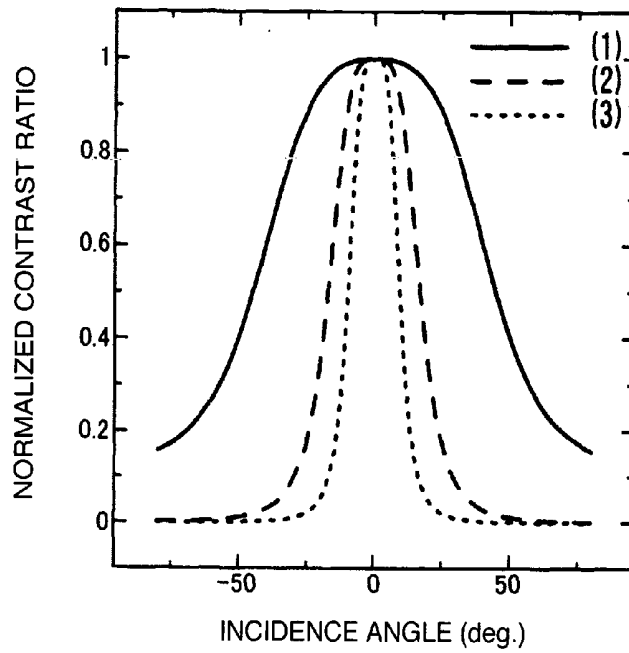

FIG.12

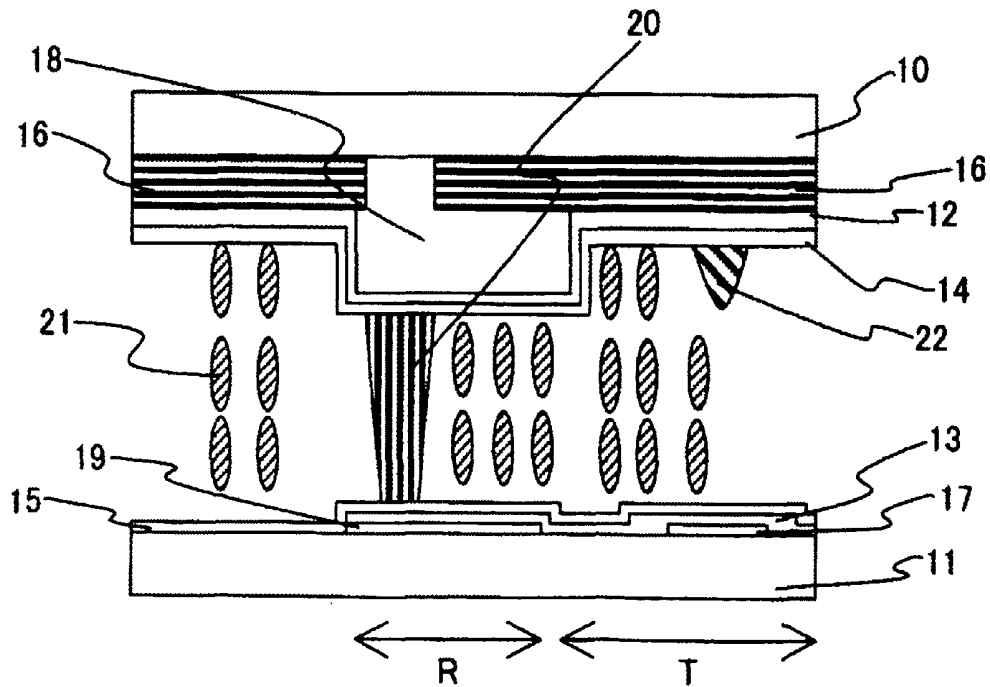

FIG.13

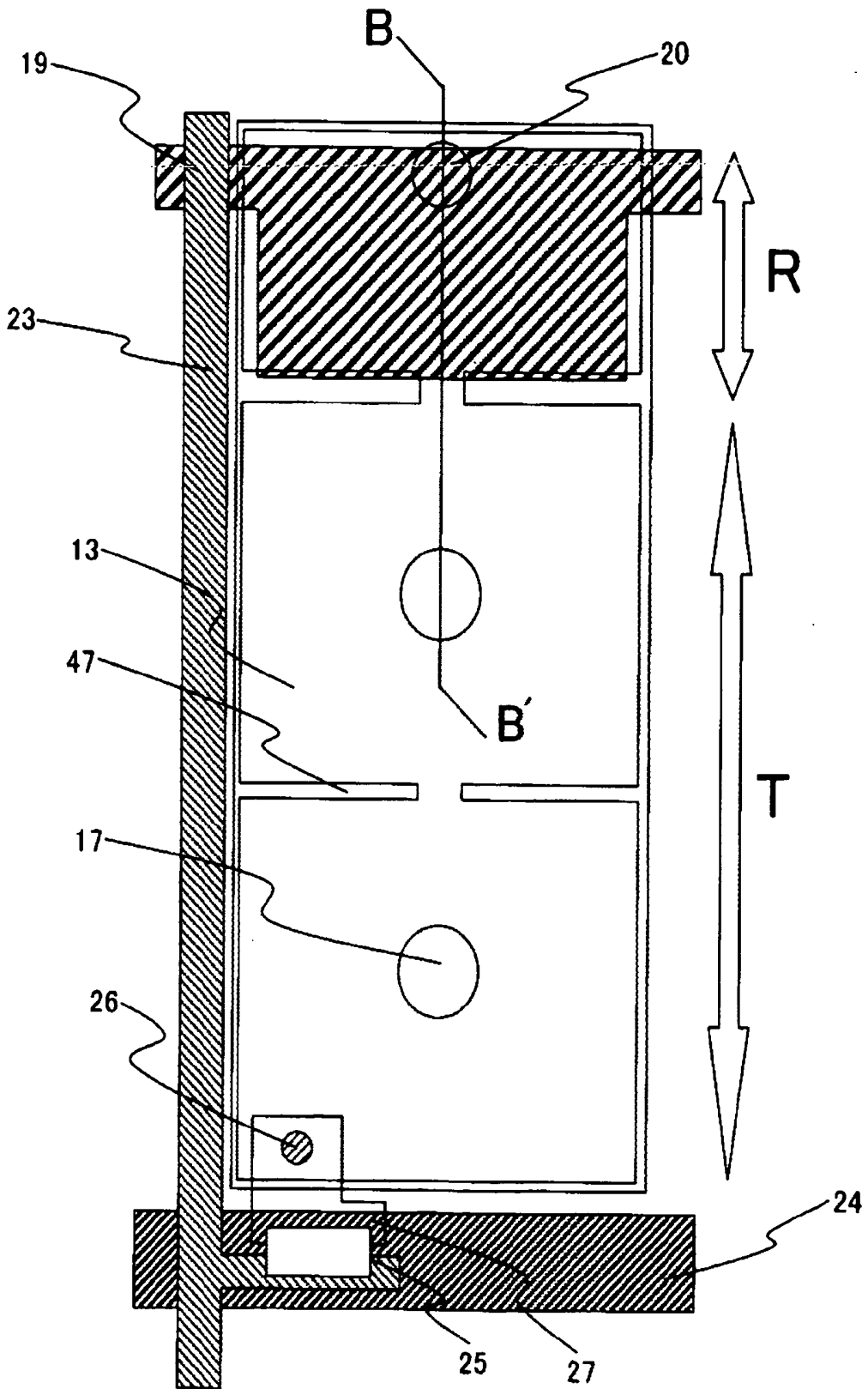

FIG. 14

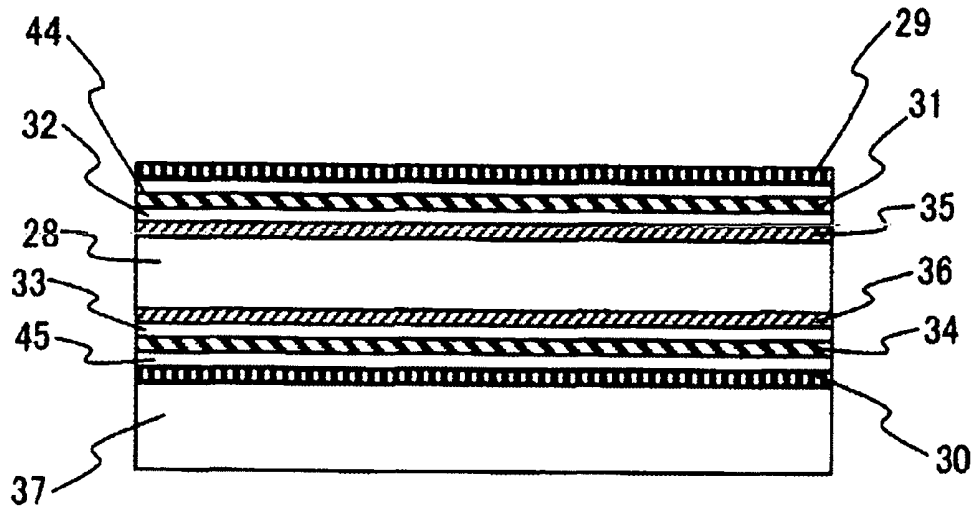

FIG. 15

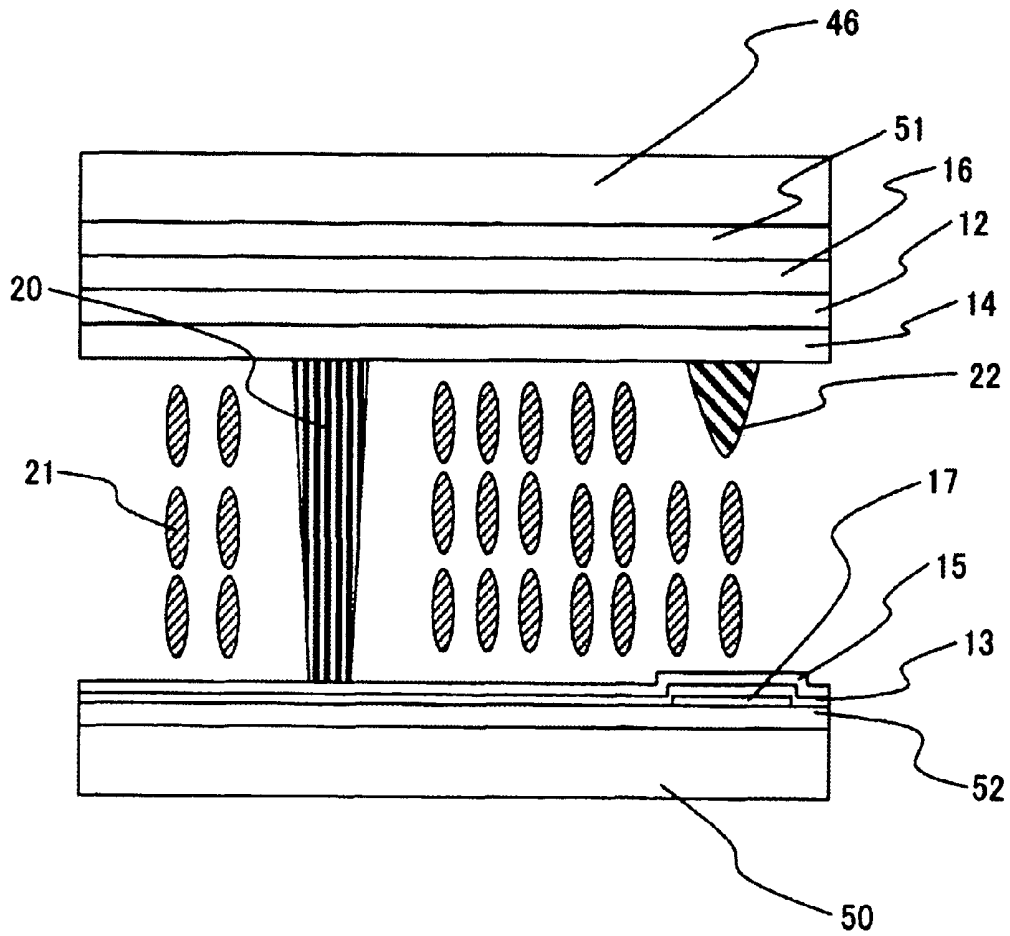
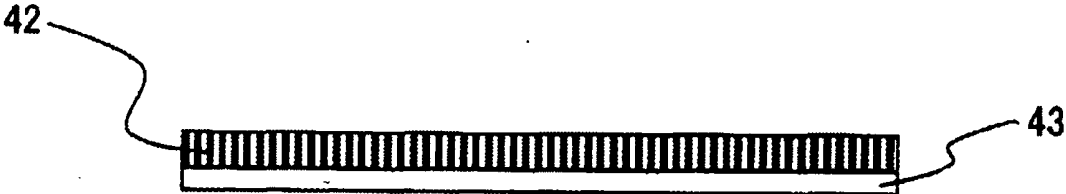

FIG.16



FIG.17



LIQUID CRYSTAL DISPLAY

BACKGROUND OF THE INVENTION

[0001] 1. Field of the Invention

[0002] The present invention relates to a liquid crystal display for displaying images.

[0003] 2. Description of the Related Art

[0004] A liquid crystal display is a non-emission type display for displaying images by adjusting an optical transmission amount and has characteristics of thinness, light weight and low consumption power.

[0005] Liquid crystal displays include a transmission type liquid crystal display and a reflection type liquid crystal display. In the transmission type liquid crystal display, a light source (hereinafter called a backlight) is disposed at the back of the display and an optical transmission amount of the backlight is adjusted to display images. In the reflection type liquid crystal display, external light such as room illumination and sun light is made incident upon the display from the front side and the optical reflection amount of the external light is adjusted to display images. There is a liquid crystal display (hereinafter called a transmissive type liquid crystal display) which can be used as a reflection type liquid crystal display in a bright environment and as a transmission type liquid crystal display in a dark environment. The transmissive type liquid crystal display has both display functions of the reflection type and transmission type, and can reduce a consumption power by turning off a backlight in the bright environment. In the dark environment, images become visible by turning on the backlight. Namely, this liquid crystal display is suitable for a liquid crystal display of a portable apparatus such as a portable phone and a digital camera which is supposed to be in various illumination environments.

[0006] One of driving modes realizing a liquid crystal display is a vertical alignment (VA) mode. Liquid crystal molecules used in the VA mode are aligned perpendicular to substrate surfaces while voltage is not applied. A pair of substrates is sandwiched between two polarization plates whose absorption axes cross at a right angle (hereinafter, this state is called cross-nicol) so that light of the backlight is intercepted by the polarization plates to present black display.

[0007] A viewing angle range during black display of a liquid crystal display in the VA mode can be broadened by disposing a retardation film called a negative C plate (hereinafter called a negative C-Plate) between the liquid crystal layer and the polarization plate. The negative C-Plate is a negative index ellipsoid which has a refractive index of almost 0 in an in-plane direction and whose refractive index in a thickness direction is smaller than the refractive index in the in-plane direction. The liquid crystal display in the VA mode adopting the negative C-Plate is therefore applied to a large size liquid crystal television which is required to have a large viewing angle.

[0008] The liquid crystal display in the VA mode adopts a multi-domain to provide a plurality of tilt directions of liquid crystal molecules and to improve color change, gradation reversal and the like during gray scale display. This can be achieved by alignment control projections, electrode slits

and the like. For example, it is possible to tilt liquid crystal molecules omnidirectionally by disposing a circular projection in a pixel center area. However, if liquid crystal molecules are tilted omnidirectionally, a black line called a domain is observed in a cross-nicol state in the area where liquid crystal molecules are tilted along a direction parallel to an absorption axis of each polarization plate and light cannot be transmitted. This may cause a lowered transmittance.

[0009] In order to avoid this, the liquid crystal display in the VA mode applied to a large size liquid crystal television has an electrode structure which makes liquid crystal molecules tilt in approximately a 45° direction relative to the absorption axis of the polarization plate. However, this electrode structure lowers an aperture ratio more than the above-described circular projection is disposed in the pixel center area. As a method of solving this issue, JP-A-5-113561 (which corresponds to EP 0538796A1) discloses a method of utilizing a circular polarization plate combining a polarization plate and a quarter wavelength plate. In this case, light transmits even in the domain region so that a high transmittance can be achieved.

[0010] In practical use, a large bandwidth circular polarization plate is adopted applying a quarter wavelength plate having low wavelength dependency. As described in JP-A-10-68816, the large bandwidth circular polarization plate can be realized by combining a polarization plate, a half wavelength plate and a quarter wavelength plate.

[0011] By applying a circular polarization plate to a liquid crystal display in the VA mode, a transmissive type liquid crystal display can be realized as described in, for example, JP-A-2003-295165 (which corresponds to U.S. 2003/0160928A1).

[0012] As described above, the liquid crystal display in the VA mode using a circular polarization plate can effectively utilize the domain region in a pixel. It is also possible to realize a transmissive type liquid crystal display suitable for portable apparatus. However, with the liquid crystal display in the VA mode adopting a circular polarization plate, a contrast ratio lowers because optical leak during black display appearing as observed along an oblique direction cannot be suppressed sufficiently even a negative C-plate is used. Namely, there arises an issue that the liquid crystal display in the VA mode using a circular polarization plate cannot obtain sufficient viewing angle characteristics.

SUMMARY OF THE INVENTION

[0013] The present invention has been made to solve the above-described issue and aims to provide a liquid crystal display capable of obtaining a high contrast ratio in a wide viewing angle range.

[0014] In order to achieve the above object, the present invention provides a liquid crystal display comprising: a first substrate and a second substrate; a liquid crystal layer sandwiched between the first substrate and the second substrate; a first polarization plate disposed on the first substrate on a side opposite to the liquid crystal layer; a second polarization plate disposed on the second substrate on a side opposite to the liquid crystal layer; one or more retardation films disposed between the first substrate and the first polarization plate and between the second substrate and

the second polarization plate; pixel electrodes disposed on one of the first substrate and the second substrate on a side of the liquid crystal layer; and a counter electrode disposed on the other of the first substrate and the second substrate on the side of the liquid crystal layer, wherein: longer axes of liquid crystal molecules of the liquid crystal layer are aligned generally perpendicular to the first substrate and the second substrate while voltage is not applied; the first polarization plate and the second polarization plate include each a polarization layer and a pair of protective layers sandwiching the polarization layer; and a retardation R_{th} of the protective layers disposed on the first polarization plate and the second polarization plate on the side opposite to the liquid crystal layer is -5 nm or larger and 5 nm or smaller.

[0015] The first and second polarization plates have each a polarization layer and a protective layer disposed on the polarization layer only on the side of the liquid crystal layer.

[0016] A positive C-Plate is disposed between the first substrate and first polarization plate and between the second substrate and second polarization plate.

[0017] A liquid crystal display can be realized which can obtain a high contrast ratio in a wide viewing angle range.

[0018] Other objects, features and advantages of the invention will become apparent from the following description of the embodiments of the invention taken in conjunction with the accompanying drawings.

BRIEF DESCRIPTION OF THE DRAWINGS

[0019] FIG. 1 is a schematic diagram showing the cross sectional structure of a liquid crystal display according to a first embodiment of the present invention.

[0020] FIG. 2 is a schematic diagram showing the cross sectional structure of a liquid crystal cell according to the first embodiment.

[0021] FIG. 3 is a diagram showing an equivalent circuit of pixels disposed in a matrix shape and constituting a pixel display area according to the first embodiment.

[0022] FIG. 4 is a plan view showing the outline structure of a pixel of a second substrate according to the first embodiment.

[0023] FIG. 5 is a schematic diagram showing the cross sectional structure of a first polarization plate according to the first embodiment.

[0024] FIG. 6 is a schematic diagram showing the cross sectional structure of a second polarization plate according to the first embodiment.

[0025] FIG. 7 is an illustrative diagram showing a relation between optical axes of a retardation film and a polarization plate of the liquid crystal display according to the first embodiment.

[0026] FIGS. 8A, 8B and 8C are graphs showing dependency of a transmittance during black display, upon R_{th} of the negative C-Plate according to the first embodiment.

[0027] FIG. 9 is a graph showing dependency of R_{th} of the negative C-Plate having the lowest transmittance during black display, upon a thickness of a liquid crystal layer 21.

[0028] FIGS. 10A and 10B are graphs showing dependency of a normalized average contrast ratio, upon an N_z coefficient, in Class I and in Class II, respectively.

[0029] FIG. 11 is a graph showing dependency of a contrast ratio along a 45° direction, upon an absorption axis of a first polarization plate according to the first embodiment.

[0030] FIG. 12 is a schematic diagram showing the cross sectional structure of a liquid crystal cell of a liquid crystal display according to a second embodiment of the present invention.

[0031] FIG. 13 is a plan view showing the outline structure of one pixel of a second substrate according to the second embodiment.

[0032] FIG. 14 is a schematic diagram showing the cross sectional structure of a liquid crystal display according to a third embodiment of the present invention.

[0033] FIG. 15 is a schematic diagram showing the cross sectional structure of a liquid crystal display according to a fourth embodiment of the present invention.

[0034] FIG. 16 is a schematic diagram showing the cross sectional structure of a first polarization plate of a liquid crystal display according to a fifth embodiment of the present invention.

[0035] FIG. 17 is a schematic diagram showing the cross sectional structure of a second polarization plate of the liquid crystal display according to the fifth embodiment.

DESCRIPTION OF THE EMBODIMENTS

[0036] A liquid crystal display in a VA mode using a circular polarization plate has light leak as observed along an oblique direction during black display. There arises an issue of a lowered contrast ratio along the oblique direction. A polarization plate used in a liquid crystal display is constituted of a polarization layer and a protective film for protecting the polarization layer. The protective film is made of a tri-acetyl cellulose (hereinafter called TAC) film. This TAC film can be regarded as a negative index ellipsoid, i.e., negative C-Plate which has a refractive index of almost 0 in an in-plane direction and whose refractive index in a thickness direction is larger than that in the in-plane direction.

[0037] In a liquid crystal display in the VA mode not using the circular polarization plate, if the TAC film as the protective layer of the polarization plate functions as a negative C-Plate, the TAC film takes a partial role of the function of the negative C-Plate originally disposed to reduce light leak, so that any problem occurs. Rather, in the liquid crystal display in the VA mode not using the circular polarization plate, the function as the negative C-Plate of the TAC film of the polarization plate is an essential element because this function is positively used to prevent light leak as observed along the oblique direction.

[0038] In a liquid crystal display in the VA mode using a circular polarization plate, a retardation film is disposed between the polarization plate and liquid crystal layer. In addition, a negative C-Plate is disposed to prevent light leak along the oblique direction. Namely, in the liquid crystal display in the VA mode using a circular polarization plate, the retardation film is disposed between the polarization

plate and negative C-Plate. In this case, since an optical element (retardation film) forming a phase difference is disposed between the negative C-Plate and the TAC film as the protective layer of the polarization plate, the function as the negative C-Plate of the TAC film does not function effectively to suppress light leak along the oblique direction. Rather, because of an unnecessary phase difference formed while light progressing along the oblique direction transmits through the TAC film, light leak is generated during black display, resulting in a lowered contrast ratio.

[0039] In order to solve this problem, a film having generally isotropic optical characteristics in an omnidirection is used in place of the TAC film as the protective layer of the polarization plate, or the protective layer is omitted. As a half wavelength plate for realizing a large bandwidth circular polarization plate, a half wavelength plate having an N_z coefficient of 0 or larger and smaller than 1 is used so that light leak can be reduced. The half wavelength plate of the invention has a relation of $n_x > n_z > n_y$.

[0040] Embodiments of the invention will be described with reference to the accompanying drawings.

First Embodiment

[0041] This embodiment is effective for improving a contrast ratio, of a liquid crystal display in a VA mode adopting a circular polarization plate, in a wide viewing angle range, by using as a protective layer of the polarization plate a film having generally isotropic optical characteristics along an omnidirection, in place of a TAC film.

[0042] FIG. 1 is a schematic diagram showing the cross sectional structure of a liquid crystal display according to the invention.

[0043] The liquid crystal display of the invention is constituted of a liquid crystal cell 28 disposed between a first polarization plate 29 and a second polarization plate 30. Three retardation films are disposed between the first polarization plate 29 and the liquid crystal cell 28. These three retardation films are a first retardation film 31, a second retardation film 32 and a first negative C-Plate 35 in this order from the first polarization plate 29 side. Similarly, three retardation films are disposed between the second polarization plate 30 and the liquid crystal cell 28. These three retardation films are a second negative C-Plate 36, a third retardation film 33 and a fourth retardation film 34 in this order from the liquid crystal cell 28 side. A backlight unit 37 is disposed on the second polarization plate 30 on the side opposite to the liquid crystal cell 28.

[0044] Namely, the negative C-Plate (first negative C-Plate 35, second negative C-Plate 36) is disposed between the first substrate 10 and retardation film and between the second substrate 11 and retardation film.

[0045] A phase difference between the first retardation film 31 and fourth retardation film 34 is a half wavelength. The first retardation film 31 and fourth retardation film 34 are made of polycarbonate, norbornene resin or the like.

[0046] A phase difference between the second retardation film 32 and third retardation film 33 is a quarter wavelength. The second retardation film 32 and third retardation film 33 are made of polycarbonate, norbornene resin or the like.

[0047] The first negative C-Plate 35 may be made of cellulose acylate such as cellulose acetate and cellulose acetate butylate, polycarbonate, polyolefin, polystyrene, polyester or the like. Synthetically, cellulose acylate is preferable, and more preferably, cellulose acetate.

[0048] The second negative C-Plate 36 may be made of material similar to that of the first negative C-Plate 35. It is desired that R_{th} of the first negative C-plate 35 and second negative C-Plate 36 is approximately the same.

[0049] The backlight unit 37 is constituted of an LED as a light source, an optical waveguide, a diffuser and the like. Although it is preferable to use a white LED, LEDs of RGB three colors may be used. The light source and structure of the backlight unit 37 are not limited to those described above, but any unit may be used if it can illuminate the liquid crystal cell from the back. For example, a cold cathode fluorescent (CCFL) tube may be used as a light source.

[0050] FIG. 5 is a schematic diagram showing the cross sectional structure of the first polarization plate 29. The first polarization plate 29 is constituted of a first polarization layer 39 made of a drawn polyvinyl alcohol (PVA) layer, and a first protective film 38 and a second protective film 40 sandwiching and protecting the first polarization layer 39. The second protective film 40, first polarization layer 39 and first protective film 38 are disposed in this order from the liquid crystal cell 28 side.

[0051] FIG. 6 is a schematic diagram showing the cross sectional structure of the second polarization plate 30. Similar to the first polarization plate, the second polarization plate 30 is constituted of a second polarization layer 42 made of a drawn PVA layer, and a third protective film 41 and a fourth protective film 43 sandwiching and protecting the second polarization layer 42. The third protective film 41, second polarization layer 42 and fourth protective film 43 are disposed in this order from the liquid crystal cell 28 side. The first polarization plate 29 and second polarization plate 30 are disposed in such a manner that the absorption axes are generally perpendicular.

[0052] FIG. 2 is a schematic diagram showing the cross sectional structure of the liquid crystal cell 28 taken along line A-A' shown in FIG. 4.

[0053] The liquid crystal cell 28 has the first substrate 10 and second substrate 11. The first substrate 10 and second substrate 11 sandwich the liquid crystal layer 21. The first substrate 10 has a color filter 16, a common electrode 12 and a first alignment film 14 on the side where the liquid crystal layer 21 is disposed. The second substrate 11 has pixel electrodes 13 and a second alignment film 15 on the side where the liquid crystal layer 21 is disposed. A columnar spacer 20 is disposed between the first substrate 10 and second substrate 11 in order to maintain constant the thickness of the liquid crystal layer 21. An alignment controlling projection 22 is disposed on the first substrate 10 on the side nearer to the liquid crystal layer 21 (in this embodiment, on the alignment film 14). A black matrix 17 is disposed on the second substrate 11 on the side nearer to the liquid crystal layer, in correspondence with the projection 22.

[0054] The first substrate 10 and second substrate 11 are transparent to allow light to transmit therethrough, and is made of, e.g., glass or plastic. However, since plastic allows

air to transmit therethrough, a gas barrier may be used by forming a nitride film or the like on the substrate surface.

[0055] The liquid crystal layer **21** is made of liquid crystal compositions having negative dielectric anisotropy providing a dielectric constant of a liquid crystal molecule in a long axis direction smaller than that in a short axis direction. The liquid crystal layer **21** is made of liquid crystal material which shows a nematic phase in a wide range including a room temperature range. The material to be used has such a high electrical resistivity as the transmittance is sufficiently retained and flicker will not occur, during a retention period under the TFT driving conditions, e.g., of a resolution of QVGA (240 lines) and a driving frequency of 60 Hz. Namely, the resistivity of the liquid crystal layer **21** is preferably $10^{12} \Omega\text{cm}^2$ or higher, or more preferably $10^{13} \Omega\text{cm}^2$ or higher.

[0056] The color filter **16** is made of red/green/blue regions through which red/green/blue light transmits, and may have a stripe layout, a delta layout or the like.

[0057] The common electrode **12** is made of transparent conductive material, e.g., indium tin oxide (hereinafter called ITO) or zinc oxide (ZnO).

[0058] The first alignment film **14** and second alignment film **15** have the function of vertically aligning liquid crystal molecules on the substrate surfaces. Although the first alignment film **14** and second alignment film **15** are preferably made of a polyimide organic film, it may be made of a SiO vertical vacuum evaporation film, a surface active agent, a chrome complex or the like.

[0059] The black matrix **17** is disposed to intercept light leak to be caused by liquid crystal alignment disturbance near the alignment control projection **22**. The material of the black matrix **17** is opaque material such as metal, and preferably chrome, tantalum molybdc, tantalum, aluminum, copper or the like.

[0060] The alignment control projection **22** is disposed in order to regulate the direction of a liquid crystal molecule which tilts upon application of an electric field. In the peripheral area of the alignment control projection **22**, the alignment direction of a liquid crystal molecule in the liquid crystal layer **21** tilts from a substrate normal in accordance with an inclination of the alignment control projection. The alignment control projection **22** is made of, e.g., acrylic resin. The projection can be formed by photo etching of acrylic resin. The alignment control method for a liquid crystal display in the VA mode is not limited only to the projection, but an electrode slit structure such as described in JP-A-7-230097 may also be used.

[0061] FIG. 3 is a diagram showing an equivalent circuit of pixels disposed in a matrix shape and constituting a pixel display area. The pixel display area has signal wirings **23** and scan wirings **24**. One pixel is shown in an area surrounded by the signal wirings **23** and scan wirings **24**. Pixels are disposed in a matrix layout. Each pixel has at least one thin film transistor **48** (hereinafter called TFT). The signal wirings **23** and scan wirings **24** are disposed generally perpendicular and TFT **48** is disposed near at a cross point of the signal wiring and scan wiring. Each pixel has at least one storage capacitor **49**. TFT **48** is connected to a through hole **26**. Although FIG. 3 uses active matrix driving by way of example, the embodiment has similar advantages also for active matrix driving.

[0062] A signal for controlling the liquid crystal layer **21** is applied to each signal wiring **23**. The material of the signal wiring **23** is low resistance conductive material and is preferably chrome, tantalum molybdc, tantalum, aluminum, copper or the like.

[0063] A signal for controlling TFT is applied to each scan wiring **24**. Similar to the signal wiring **23**, the material of the scan wiring **24** is preferably chrome, tantalum molybdc, tantalum, aluminum, copper or the like.

[0064] The storage capacitor **49** is disposed in order to prevent a retained image signal from being leaked.

[0065] FIG. 4 is a plan view showing the outline structure of one pixel of the second substrate **11**. TFT **48** is inversely staggered, and has a semiconductor layer **25** in the channel region and a through hole **26** for interconnecting a pixel electrode **13** and a source electrode **27**. The black matrix **17** is disposed in an area approximately corresponding to the alignment control projection **22** disposed on the counter first substrate **10**.

[0066] The pixel electrode **13** is disposed in order to apply an electric field to the liquid crystal layer **21**. The pixel electrode **13** is made of material similar to that of the common electrode **12**. An electrode slit portion **47** is provided near the pixel center area of the pixel electrode **13**.

[0067] It is desired that a liquid crystal display in the VA mode has a multi-domain to provide a plurality of tilt directions of liquid crystal molecules and to improve color change, gradation reversal and the like during gray scale display. In this embodiment, since liquid crystal molecules tilt omnidirectionally around the alignment control projection **22**, the multi-domain can be realized. However, if liquid crystal molecules are tilted omnidirectionally, a black line called a domain is observed in a cross-nicol state in the area where liquid crystal molecules are tilted along a direction parallel to an absorption axis of each polarization plate and light cannot be transmitted. This domain may cause a lowered transmittance. In order to avoid this, there is a method of utilizing a circular polarization plate. By using the circular polarization plate, light can transmit even in the domain region.

[0068] It has been proposed that a negative C-Plate is disposed between each of the polarization plates **29** and **30** and the liquid crystal layer of a liquid crystal display in the VA mode in order to reduce light leak to be observed along an oblique direction during black display. The negative C-Plate is an optical element which can be regarded as an optically negative index ellipsoid which has a refractive index of almost 0 in an in-plane direction and whose refractive index in a thickness direction is smaller than the refractive index in the in-plane direction. The negative index ellipsoid is represented by a retardation (hereinafter called R_{th}) in a thickness direction expressed by the following equation:

$$R_{th} = \left(\frac{n_x + n_y}{2} - n_z \right) \cdot d \quad (1)$$

[0069] wherein n_x , n_y and n_z are refractive indices along main axes directions of the index ellipsoid, n_x and n_y are

refractive indices along the in-plane direction and n_z is a refractive index along the thickness direction. d is a thickness of the retardation film (in this example, negative C-Plate). The liquid crystal layer of a liquid crystal display in the VA mode during black display can be regarded as an optically positive index ellipsoid which has a refractive index difference of almost 0 in an in-plane direction and whose refractive index in a thickness direction is smaller than the refractive index in the in-plane direction. Namely, the negative C-Plate which can be regarded as an optically negative index ellipsoid can compensate for the liquid crystal layer which can be regarded as an optically positive index ellipsoid. It is therefore desired not to dispose an optical element between the liquid crystal layer and the negative C-Plates disposed to suppress light leak along an oblique direction.

[0070] A polarization plate used by a liquid crystal display has generally the structure that a polarization film made of polyvinyl alcohol (hereinafter called PVA) adsorbing iodine to impart a polarization function is sandwiched between protective films made of a tri-acetyl cellulose (hereinafter called TAC) film. Generally, the TAC film can be regarded as a negative index ellipsoid, i.e., negative C-Plate which has a refractive index difference of almost 0 in the in-plane direction and whose refractive index in the thickness direction is smaller than a refractive index in the in-plane direction.

[0071] In a liquid crystal display in the VA mode not using a circular polarization plate, as the TAC film as the protective film of the polarization plate functions as the negative C-Plate, the TAC film takes a partial role of the function of the negative C-plate disposed to reduce light leak along the oblique direction so that any problem will not occur. Rather, in the liquid crystal display in the VA mode not using a circular polarization plate, the negative C-Plate function of the TAC film of the polarization plate is an essential element to be positively used for preventing light leak to be observed along the oblique direction.

[0072] On the other hand, in a liquid crystal display in the VA mode using a circular polarization plate, generally two positive A plates (hereinafter called A-Plate) are disposed between the polarization plates and the liquid crystal layer, as quarter wavelength plates for realizing large bandwidth circular polarization plates, and in addition, negative C-Plates are disposed to prevent light leak along the oblique direction. The positive A-Plate is a uniaxial retardation film having an N_z coefficient of 1.0. The N_z coefficient is defined by the following equation:

$$N_z = \frac{n_x - n_z}{n_x - n_y} \quad (2)$$

[0073] Since C-Plate has a relation of $n_x > n_y = n_z$, the N_z coefficient is 1.0. In the liquid crystal display in the VA mode using a circular polarization plate, retardation films exist between the polarization plate and negative C-Plate. In this case, since there exist optical elements (retardation films) forming a phase difference between the polarization plate and negative C-Plate, the function of the TAC film as the negative C-Plate cannot operate effectively to suppress light leak along the oblique direction. Rather, light progressing

along the oblique direction becomes light leak during black display because of an unnecessary phase difference while the light transmits through the TAC films, resulting in a lowered contrast ratio.

[0074] FIG. 7 is a schematic diagram showing a relation between optical axes of the retardation film and polarization plate of the liquid crystal display of the present invention shown in FIG. 1. In order to realize a large bandwidth circular polarization plate, it is necessary to dispose retardation films as shown in FIG. 7. It is desired that the delay axes of the first retardation film 31 and fourth retardation film 34 and the delay axes of the second retardation film 32 and second retardation film 33 are generally perpendicular. In addition, for the relation between the absorption axes of the first and second polarization plates and the delay axes of the first to fourth retardation films, it is desired that the delay axis of the first retardation film 31 is -105° , the delay axis of the second retardation film 32 is 15° , a delay axis of the third retardation film 33 is -75° , the delay axis of the fourth retardation film 34 is -15° , the absorption axis of the second polarization plate 30 is -90° , assuming that the absorption axis of the first polarization plate is 0° .

[0075] The second protective film 40 and third protective film 41 of the polarization plates of the present invention shown in FIGS. 5 and 6 are desired to have R_{th} of 0 in order to reduce light leak to be observed along the oblique direction. However, the actual value is -5 nm or larger and 5 nm or smaller because of manufacture errors, variations and the like. This range ensures sufficient advantages. The material of the second protective film 40 and third protective film 41 is desired to be material having a smaller R_{th} than that of a conventionally used TAC film, such as norbornene resin.

[0076] In order to further reduce light leak along the oblique direction during black display, it is desired to use the first retardation film 31 and fourth retardation film 34 having the N_z coefficient of 0 or larger and smaller than 1. An optimum N_z coefficient of the first retardation film 31 and fourth retardation film 34 is determined from a retardation (hereinafter called R_c) of the liquid crystal layer 21 in the in-plane and R_{th} of the first negative C-Plate 35 and second negative C-Plate 36.

[0077] FIGS. 8A, 8B and 8C are diagrams showing dependency of a transmittance during black display, upon R_{th} of the negative C-Plate. Theoretical calculations were conducted under the following conditions in order to confirm the advantages of the present invention which can reduce light leak along the oblique direction. A birefringence Δn of the liquid crystal layer 21 was set to 0.099 and a wavelength of incidence light was set to 550 nm. A thickness of the liquid crystal layer 21 was set to $3 \mu\text{m}$ to $5 \mu\text{m}$. R_{th} of the first negative C-Plate and second negative C-Plate was the same.

[0078] A thickness of the liquid crystal layer 21 was $3.5 \mu\text{m}$ from calculation results shown in FIGS. 8A, 8B and 8C. A light incidence angle was set to 60° , and three azimuth directions were used: 0° (FIG. 8A), 30° (FIG. 8B) and 45° (FIG. 8C) from the absorption axis of the first polarization plate 29. The N_z coefficients of the first retardation film 31 and fourth retardation film 34 were changed from 0.1 to 1.0 at an interval of 0.1. It can be understood from the calculation results that the transmittance during black display depends upon R_{th} of the negative C-Plate.

[0079] FIG. 9 is a graph showing dependency of R_{th} of the negative C-Plate having the lowest transmittance during black display, upon a thickness of the liquid crystal layer 21. It can be understood from these results that an optimum R_{th} of the negative C-Plate is approximately proportional to a thickness of the liquid crystal layer 21.

[0080] The viewing angle characteristics of a contrast ratio have been studied by using an optimum R_{th} of the negative C-Plate. The viewing angle characteristics were evaluated by Class I and Class II of ISO13406-2 (Ergonomic requirement for flat panel display). θ_{range} of Class II is $\pm 22^\circ$ as viewed from the substrate front under the conditions that a width across corners of the liquid crystal display is 2.2 inches and a distance between the liquid crystal display and the viewer's eyes is 300 mm. Class I assumes that many people view a display, and θ_{range} is defined as $\pm 40^\circ$. An average contrast ratio was obtained in each θ_{range} . The average contrast ratio is an average obtained through surface integral along an omnidirection of contrast ratios in the polar angle range from a direction (0°) perpendicular to the substrate surface to θ_{range} .

[0081] FIGS. 10A and 10B are graphs showing dependency of a normalized average contrast ratio upon an N_z coefficient, in Class I (FIG. 10A) and in Class II (FIG. 10B), respectively. The normalized average contrast ratio is a value normalized by setting a maximum average contrast ratio (under these conditions, a thickness of the liquid crystal layer 21 is $3.5 \mu\text{m}$ and a N_z coefficient is 0.4) to 1.

[0082] As shown in FIGS. 10A and 10B, an inflection point appears near at N_z points of 0.2 and 0.7. Therefore, under the conditions that a thickness of the liquid crystal layer 21 is set to $3 \mu\text{m}$ to $5 \mu\text{m}$ (in this case, a birefringence of liquid crystal is 0.099) and R_{th} of the negative C-Plate is set to 80 nm or larger and 160 nm or smaller, it is desired that the N_z coefficient is in a range of 0.2 or larger and 0.7 or smaller in order to reduce light leak to be observed along the oblique direction, and it is desired that a thickness of the liquid crystal layer is $3.5 \mu\text{m}$, R_{th} of the negative C-Plate is 90 nm, and the N_z coefficient of the half wavelength plate is 0.4.

[0083] FIG. 11 is a diagram showing incidence angle dependency of a contrast ratio along a 45° direction relative to an absorption axis of the first polarization plate, under the following three conditions:

[0084] (1) The N_z coefficients of the first retardation film 31 and fourth retardation film 34 are 0.4. R_{th} of the second protective film 40 and third protective film 41 is 0 nm.

[0085] (2) The N_z coefficients of the first retardation film 31 and fourth retardation film 34 are 0.4. R_{th} of the second protective film 40 and third protective film 41 is 37 nm.

[0086] (3) The N_z coefficients of the first retardation film 31 and fourth retardation film 34 are 1. R_{th} of the second protective film 40 and third protective film 41 is 37 nm.

[0087] As seen from FIG. 11, high contrast ratios along the oblique direction can be obtained in the order of (1)>(2)>(3).

[0088] According to the above-described results, the present invention provides a liquid crystal display in the VA mode using a circular polarization plate capable of reducing

light leak along the oblique direction and obtaining a high contrast ratio in a wide viewing angle range.

Second Embodiment

[0089] Next, the second embodiment will be described with reference to the accompanying drawings. A transmissive liquid crystal display can be realized by applying a circular polarization plate to a liquid crystal display in the VA mode. The layout of polarization plates and retardation films of a transmissive liquid crystal display in the VA mode of the second embodiment is similar to that of the first embodiment, and the advantages similar to those of the first embodiment can be obtained.

[0090] FIG. 12 is a schematic diagram showing the cross sectional structure of a liquid crystal cell 28 of the transmissive liquid crystal display in the VA mode, taken along line B-B' shown in FIG. 13. The transmissive liquid crystal display of the second embodiment has a transmission area (T area in FIG. 12) and a reflection area (R area in FIG. 12) in one pixel. The liquid crystal cell 28 has a first substrate 10, a liquid crystal layer 21 and a second substrate 11, and the first substrate 10 and second substrate 11 sandwiches the liquid crystal layer 21. The first substrate 10 has a color filter 16, a common electrode 12 and a first alignment film 14 on the liquid crystal layer 21 side. The second substrate 11 has pixel electrodes 13 and a second alignment film 15 on the liquid crystal layer 21 side. A reflection plate 19 is disposed in the reflection area of the second substrate 11 on the liquid crystal layer 21 side. A stepped region 18 is disposed in the reflection area of the first substrate 10 on the liquid crystal layer 21 side. The stepped region 18 has a columnar spacer 20 for maintaining constant the thickness of the liquid crystal layer 21. An alignment control projection 22 is provided on the common electrode 12 side nearer to the liquid crystal layer 21. A black matrix 17 is disposed on the second substrate 11 nearer to the liquid crystal layer.

[0091] FIG. 13 is a plan view showing the outline structure of one pixel of the second substrate 11. A transmissive liquid crystal display requires a reflection plate to reflect incidence light. The reflection plate 19 for reflecting incidence light is therefore disposed in the reflection area such as shown in FIG. 13.

[0092] The reflection plate 19 is provided for reflection display in order to reflect external light incident upon the first substrate. It is desired that the reflection plate 19 has an irregular surface in order to diffuse reflected light. The reflection plate 19 is connected to the pixel electrode 13 in order to make the transmission area and reflection area have the same potential. Since the reflection plate 19 has a role of a pixel electrode in the reflection area, it is desired that the reflection plate is made of high conductivity metal. It is particularly desired that the reflection plate 19 is made of silver, aluminum or the like which has a high reflectivity in a visual range and excellent conductivity.

[0093] The stepped region 18 is made of resist material. In a transmissive liquid crystal display, it is desired that R_c in the reflection area of the liquid crystal layer 21 is set to a half of R_c in the transmission area, in order to make coincident the transmittance characteristics relative to voltage in the transmission area and the transmittance characteristics relative to voltage in the reflection area. It is therefore desired that a step is provided to the reflection area to set a thickness

of the liquid crystal layer **21** in the reflection area to a half of a thickness of the liquid crystal layer in the transmission area.

[0094] With the above-described structure, the transmission area of the transmissive liquid crystal display of the second embodiment is substantially and optically equivalent to the transmission area of the liquid crystal display of the first embodiment. Therefore, the transmission characteristics of the transmissive liquid crystal display of this embodiment provide the advantages similar to those of the first embodiment, by using a generally optically isotropic film as the protective film of the polarization plate and by using retardation films having the N_z coefficient of 0 or larger and smaller than 1 as the first retardation film **31** and fourth retardation film **34**. It is therefore possible for a liquid crystal display in the VA mode using a circular polarization plate to reduce light leak along the oblique direction and obtain a high contrast ratio in a wide viewing angle range.

Third Embodiment

[0095] Next, the third embodiment will be described with reference to the accompanying drawings. In the third embodiment, a positive C-Plate for compensating for a phase difference of a TAC film is disposed between a negative C-Plate and the TAC film to thereby obtain advantages similar to those when the phase difference of the protective layer is set to 0.

[0096] FIG. 14 is a schematic diagram showing the cross sectional structure of a liquid crystal display according to the third embodiment. The liquid crystal display of this embodiment is constituted of a liquid crystal cell **28** disposed between a first polarization plate **29** and a second polarization plate **30**. Four retardation films are disposed between the first polarization plate **29** and liquid crystal cell **28**. The four retardation films include a first positive C-Plate (hereinafter called a positive C-Plate) **44**, a first retardation film **31**, a second retardation film **32** and a first negative C-Plate **35** in this order from the first polarization plate **29** side. Similarly, four retardation films are disposed between the second polarization plate **30** and liquid crystal cell **28**. The four retardation films include a second negative C-Plate **36**, a third retardation film **33**, a fourth retardation film **34** and a second positive C-Plate **45** in this order from the side nearer to the liquid crystal cell **28**. A backlight unit **37** is disposed on the second retardation film **30** on the side opposite to the liquid crystal cell **28**.

[0097] Namely, the liquid crystal display has the structure that the positive C-Plate (first positive C-Plate **44** and second positive C-Plate **45**) is disposed between the first substrate **10** and first polarization plate **29** and between the second substrate **11** and second polarization plate **30**.

[0098] The structure of the first retardation film **31** to fourth retardation film **34** is similar to that of the first or second embodiment.

[0099] The first positive C-Plate **44** can be regarded as an optically positive index ellipsoid which has a refractive index difference of almost 0 in the in-plane direction and whose refractive index in the thickness direction is larger than a refractive index in the in-plane direction. By setting the optical characteristics of the TAC film capable of being regarded as the negative C-Plate equal to the optical char-

acteristics of the positive C-Plate, a phase difference of the TAC film can be compensated. However, even if R_{th} of the first positive C-Plate **44** is set almost equal to R_{th} of the second protective film **40**, it is indicated that if the refractive index of the index ellipsoid in the main axis direction is different, the retardation films have different angle retardation characteristics (Liquid Crystal Forum (PC05), 2004: Toshiuki HYUUGA, Takahiro ISHINABE, Tatsuo UCHIDA).

[0100] It is therefore desired that approximately the same design parameter T_z representative of the angle characteristics of a retardation film defined in the following is used for both the first positive C-Plate **44** and second protective film **40**:

$$T_z = \frac{n_x \sqrt{n_z^2 - 1} - n_y \sqrt{n_y^2 - 1}}{n_z \cdot (n_x - n_y)} \quad (3)$$

[0101] The first positive C-Plate **44** can be manufactured by forming a film of homeotropic alignment polymer liquid crystal or molding uniaxially compressed polymer or acetate cellulose.

[0102] Similar to the first positive C-Plate **44**, it is desired that T_z of the second positive C-Plate **45** is set to approximately the same T_z as that of the second protective film **40**. The second positive C-Plate **45** can be manufactured by forming a film of homeotropic alignment polymer liquid crystal or molding uniaxially compressed polymer or acetate cellulose.

[0103] The structure of the liquid crystal cell **28** is similar to that of the first or second embodiment.

[0104] By using the positive C-Plate, this embodiment can obtain generally the same advantages as those of using an optically isotropic film as a substitution for the TAC film which is the protective film of the retardation film described in the first and second embodiments. It is therefore possible to mitigate light leak along the oblique direction of a liquid crystal display in the VA mode using a circular polarization plate and obtain a high contrast ratio in a wide viewing angle range.

Fourth Embodiment

[0105] Next, the fourth embodiment will be described with reference to the accompanying drawing. This embodiment changes the structure of the liquid crystal cell **28** of a liquid crystal display similar to that shown in FIG. 1. FIG. 15 is a schematic diagram showing the cross sectional structure of a liquid crystal display according to the fourth embodiment. The liquid crystal cell **28** of this embodiment has a first substrate **10** and second substrate **11** sandwiching a liquid crystal layer **21**. The first substrate **10** and second substrate **11** may be a first film substrate **46** and a second film substrate **50** made of plastic or polyether sulfone (hereinafter called PES) other than glass. A first gas barrier **51** and a second gas barrier **52** are disposed on the first film substrate **46** and second film substrate **50**, respectively.

[0106] The first film substrate **46** and second film substrate **50** may be replaced with retardation films: a first negative

C-Plate **35** and a second negative C-Plate **36**, respectively. Namely, one of or both the first film substrate **46** and second film substrate **50** may have the function of an optically positive index ellipsoid which has a refractive index difference of almost 0 in the in-plane direction and whose refractive index in the thickness direction is larger than a refractive index in the in-plane direction.

[0107] One of or both the first film substrate **46** and second film substrate **50** may have the structure having a quarter wavelength phase difference or a half wavelength phase difference.

[0108] The first gas barrier **51** is provided to prevent air from transmitting through the first film substrate **46**. The first gas barrier **51** can be formed by forming a nitride film or the like on the substrate surface.

[0109] Similar to the first gas barrier, the second gas barrier **52** is provided to prevent air from transmitting through the second film substrate **50**. Similar to the first gas barrier **51**, the second gas barrier **52** can be formed by forming a nitride film or the like on the substrate surface. It is necessary to use the gas barrier if the retardation film is used as a substitute substrate. In this case, a silicon nitride film or the like is formed on the retardation film.

[0110] The structure of the liquid crystal cell **28** is similar to that described in the first to third embodiments.

[0111] The layout of the retardation films is similar to that described in the first embodiment. If the substitute substrate has a phase difference, it is necessary to re-consider the layout of retardation films. For example, if the phase difference of the substitute substrate is generally equal to that of the negative C-Plate, the first negative C-Plate **35** and second negative C-Plate **36** may be removed or their R_{th} may be lowered.

[0112] A color filter **16** can be formed on the film substrate by utilizing Roll-to-Roll techniques such as techniques described in IDW' 04 Proceedings, FMC3-3, p. 579, T. Eguchi, et. al.

[0113] In this embodiment, by using a plastic substrate or a film substrate as one of or both the first substrate **10** and second substrate **11**, it is possible to make a liquid crystal display light and thin and obtain a high contrast ratio in a wide viewing angle range.

Fifth Embodiment

[0114] Next, the fifth embodiment will be described with reference to the accompanying drawings. This embodiment has the advantages that a contrast ratio can be improved in a wide viewing angle range by removing the TAC film as the protective layer of the retardation film of a liquid crystal display in the VA mode using a circular polarization plate.

[0115] FIGS. 16 and 17 are schematic diagrams showing cross sectional structures of a first polarization plate **29** and a second polarization plate **30** used by the liquid crystal display of this embodiment.

[0116] A conventional polarization plate has TAC films as protective layers. However, as described above, a phase difference of the TAC film of a liquid crystal display in the VA mode having a circular polarization plate results in a lowered contrast ratio. In the liquid crystal display of this

embodiment, the retardation film is provided with the function of the protective film is provided, and the protective layer disposed on the polarization plate in the liquid crystal layer side is omitted. Namely, a first protective film **38** is disposed on a first polarization layer **39** on the side opposite to a liquid crystal layer **21**, whereas a second protective film **43** is disposed on a second polarization layer **42** on the side opposite to the liquid crystal layer **21**, to thereby obtain advantages similar to those of the first embodiment.

[0117] A first polarization plate **29** and a second polarization plate **30** do not have a second protective film **40** and a third protective film **41**, and a first polarization layer **39** and a second polarization layer **42** are disposed directly on retardation films. A polarization layer which does not require a protective film may be used, and this layer can be achieved by using enzyme synthesis amylose or the like.

[0118] The structure of a liquid crystal cell **28** is similar to that described in the first to third embodiments.

[0119] The layout of retardation films is similar to that described in the first embodiment.

[0120] The embodiment can obtain a high contrast ratio in a wide viewing angle range while realizing a thin, low cost liquid crystal display.

[0121] It should be further understood by those skilled in the art that although the foregoing description has been made on embodiments of the invention, the invention is not limited thereto and various changes and modifications may be made without departing from the spirit of the invention and the scope of the appended claims.

1. A liquid crystal display comprising:

- a first substrate and a second substrate;
- a liquid crystal layer sandwiched between said first substrate and said second substrate;
- a first polarization plate disposed on said first substrate on a side opposite to said liquid crystal layer;
- a second polarization plate disposed on said second substrate on a side opposite to said liquid crystal layer;
- one or more retardation films disposed between said first substrate and said first polarization plate and between said second substrate and said second polarization plate;
- pixel electrodes disposed on one of said first substrate and said second substrate on a side of said liquid crystal layer; and
- a counter electrode disposed on the other of said first substrate and said second substrate on the side of said liquid crystal layer,

wherein:

longer axes of liquid crystal molecules of said liquid crystal layer are aligned generally perpendicular to said first substrate and said second substrate while voltage is not applied;

said first polarization plate and said second polarization plate include each a polarization layer and a pair of protective layers sandwiching said polarization layer; and

a retardation R_{th} of said protective layers disposed on said first polarization plate and said second polarization plate on the side opposite to said liquid crystal layer is -5 nm or larger and 5 nm or smaller.

2. A liquid crystal display comprising:

a first substrate and a second substrate;

a liquid crystal layer sandwiched between said first substrate and said second substrate;

a first polarization plate disposed on said first substrate on a side opposite to said liquid crystal layer;

a second polarization plate disposed on said second substrate on a side opposite to said liquid crystal layer;

one or more retardation films disposed between said first substrate and said first polarization plate and between said second substrate and said second polarization plate;

pixel electrodes disposed on one of said first substrate and said second substrate on a side of said liquid crystal layer; and

a counter electrode disposed on the other of said first substrate and said second substrate on the side of said liquid crystal layer,

wherein:

longer axes of liquid crystal molecules of said liquid crystal layer are aligned generally perpendicular to said first substrate and said second substrate while voltage is not applied; and

said first polarization plate and said second polarization plate include each a polarization layer and a protective layer disposed on said polarization layer only on the side opposite to said liquid crystal layer.

3. A liquid crystal display comprising:

a first substrate and a second substrate;

a liquid crystal layer sandwiched between said first substrate and said second substrate;

a first polarization plate disposed on said first substrate on a side opposite to said liquid crystal layer;

a second polarization plate disposed on said second substrate on a side opposite to said liquid crystal layer;

one or more retardation films disposed between said first substrate and said first polarization plate and between said second substrate and said second polarization plate;

pixel electrodes disposed on one of said first substrate and said second substrate on a side of said liquid crystal layer; and

a counter electrode disposed on the other of said first substrate and said second substrate on the side of said liquid crystal layer,

wherein:

longer axes of liquid crystal molecules of said liquid crystal layer are aligned generally perpendicular to said first substrate and said second substrate while voltage is not applied; and

a positive C-Plate is disposed between said first substrate and said first polarization plate and between said second substrate and said second polarization plate.

4. The liquid crystal display according to claim 1, wherein a plurality of pixels disposed in a matrix shape are provided and each of said plurality of pixels has a transmission area and a reflection area.

5. The liquid crystal display according to claim 1, wherein said retardation film includes a first retardation film having a quarter wavelength phase difference on a side where said liquid crystal layer is disposed and a second retardation film having a half wavelength phase difference on a side where said first polarization plate said second polarization plate are disposed.

6. The liquid crystal display according to claim 1, wherein a negative C-Plate is provided between said first substrate and said retardation film and between said second substrate and said retardation film.

7. The liquid crystal display according to claim 1, wherein:

said retardation film includes a first retardation film having a quarter wavelength phase difference on a side where said liquid crystal layer is disposed and a second retardation film having a half wavelength phase difference on a side where said first polarization plate said second polarization plate are disposed; and

an N_z coefficient of said second retardation film is 0 or larger and smaller than 1.

8. The liquid crystal display according to claim 1, wherein signal lines and scan lines disposed on said first substrate or said second substrate, and a thin film transistor is disposed at each cross point between said signal line and said scan line.

9. The liquid crystal display according to claim 1, wherein a color filter is disposed on said first substrate or said second substrate on a side of said liquid crystal layer.

10. The liquid crystal display according to claim 1, wherein one of or both said first substrate and said second substrate are made of polymer material.

11. The liquid crystal display according to claim 1, wherein one of or both said first substrate and said second substrate have a quarter wavelength phase difference or a half wavelength phase difference.

12. The liquid crystal display according to claim 1, wherein one of or both said first substrate and said second substrate have a function of an optically positive index ellipsoid which has a refractive index of almost 0 in an in-plane direction and whose refractive index in a thickness direction is larger than a refractive index in the in-plane direction.

13. The liquid crystal display according to claim 2, wherein said retardation film includes a first retardation film having a quarter wavelength phase difference on a side where said liquid crystal layer is disposed and a second retardation film having a half wavelength phase difference on a side where said first polarization plate said second polarization plate are disposed.

14. The liquid crystal display according to claim 2, wherein a negative C-Plate is provided between said first substrate and said retardation film and between said second substrate and said retardation film.

15. The liquid crystal display according to claim 2, wherein:

said retardation film includes a first retardation film having a quarter wavelength phase difference on a side where said liquid crystal layer is disposed and a second retardation film having a half wavelength phase difference on a side where said first polarization plate said second polarization plate are disposed; and

an N_z coefficient of said second retardation film is 0 or larger and smaller than 1.

16. The liquid crystal display according to claim 2, wherein signal lines and scan lines disposed on said first substrate or said second substrate, and a thin film transistor is disposed at each cross point between said signal line and said scan line.

17. The liquid crystal display according to claim 2, wherein a color filter is disposed on said first substrate or said second substrate on a side of said liquid crystal layer.

18. The liquid crystal display according to claim 2, wherein one of or both said first substrate and said second substrate are made of polymer material.

19. The liquid crystal display according to claim 2, wherein one of or both said first substrate and said second substrate have a quarter wavelength phase difference or a half wavelength phase difference.

20. The liquid crystal display according to claim 2, wherein one of or both said first substrate and said second substrate have a function of an optically positive index ellipsoid which has a refractive index of almost 0 in an in-plate direction and whose refractive index in a thickness direction is larger than a refractive index in the in-plane direction.

* * * * *

专利名称(译)	液晶显示器		
公开(公告)号	US20060221280A1	公开(公告)日	2006-10-05
申请号	US11/356188	申请日	2006-02-17
[标]申请(专利权)人(译)	OKA SHINICHIRO 安达MASAYA 高村正彦SHINICHI 桧山郁夫		
申请(专利权)人(译)	OKA SHINICHIRO 安达MASAYA 高村正彦SHINICHI 桧山郁夫		
当前申请(专利权)人(译)	松下液晶显示CO., LTD.		
[标]发明人	OKA SHINICHIRO ADACHI MASAYA KOMURA SHINICHI HIYAMA IKUO		
发明人	OKA, SHINICHIRO ADACHI, MASAYA KOMURA, SHINICHI HIYAMA, IKUO		
IPC分类号	G02F1/1335		
CPC分类号	G02F1/133528 G02F1/133634 G02F2413/13 G02F2201/50 G02F2001/133742		
优先权	2005100483 2005-03-31 JP		
其他公开文献	US7733449		
外部链接	Espacenet USPTO		

摘要(译)

提供一种使用圆偏振板的垂直取向 (VA) 模式的液晶显示器, 其可以减少沿倾斜方向观察到的漏光并实现高对比度。VA模式在初始对准状态下使用垂直对准的液晶层。在全方向上具有通常各向同性光学特性的膜用作液晶单元侧的保护膜, 设置在液晶单元外部的第一和第二偏振板, 并且第一和第四延迟膜具有小于1的Nz系数。

