



(19) **United States**

(12) **Patent Application Publication**
Ha

(10) **Pub. No.: US 2002/0047820 A1**

(43) **Pub. Date: Apr. 25, 2002**

(54) **LIQUID CRYSTAL DISPLAY DEVICE AND METHOD FOR DRIVING THE SAME**

Publication Classification

(51) **Int. Cl.⁷ G09G 3/36**

(76) **Inventor: Yong Min Ha, Kyongsangbuk-do (KR)**

(52) **U.S. Cl. 345/87**

Correspondence Address:
MORGAN LEWIS & BOCKIUS LLP
1111 PENNSYLVANIA AVENUE NW
WASHINGTON, DC 20004 (US)

(57) **ABSTRACT**

A liquid crystal display (LCD) device having a first substrate and a second substrate with liquid crystal sealed therebetween, includes a plurality of gate lines and data lines crossing each other on the first substrate; a gate driving section for driving the gate lines; a source driving section for precharging the data lines for a first time and supplying video signals to the data lines; and a precharge circuit section for precharging the data lines for a second time.

(21) **Appl. No.: 09/894,908**

(22) **Filed: Jun. 29, 2001**

(30) **Foreign Application Priority Data**

Aug. 30, 2000 (KR) P2000-50770

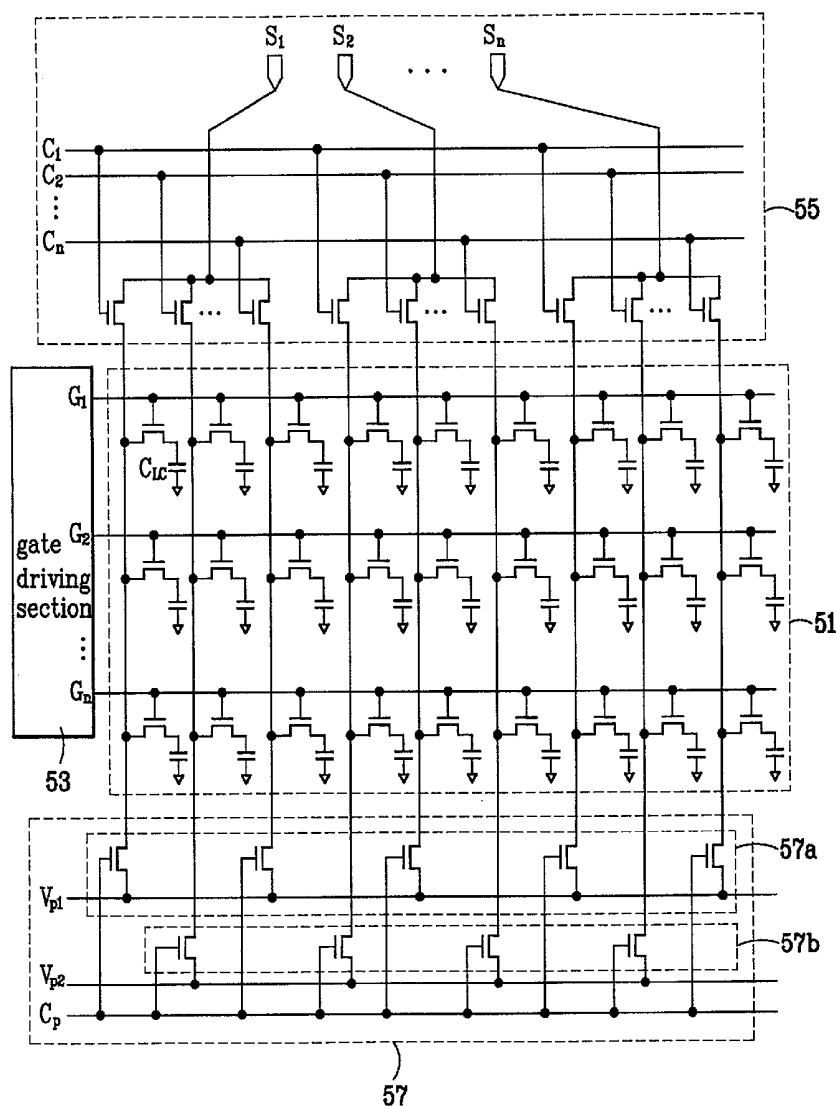

FIG.1
Related Art

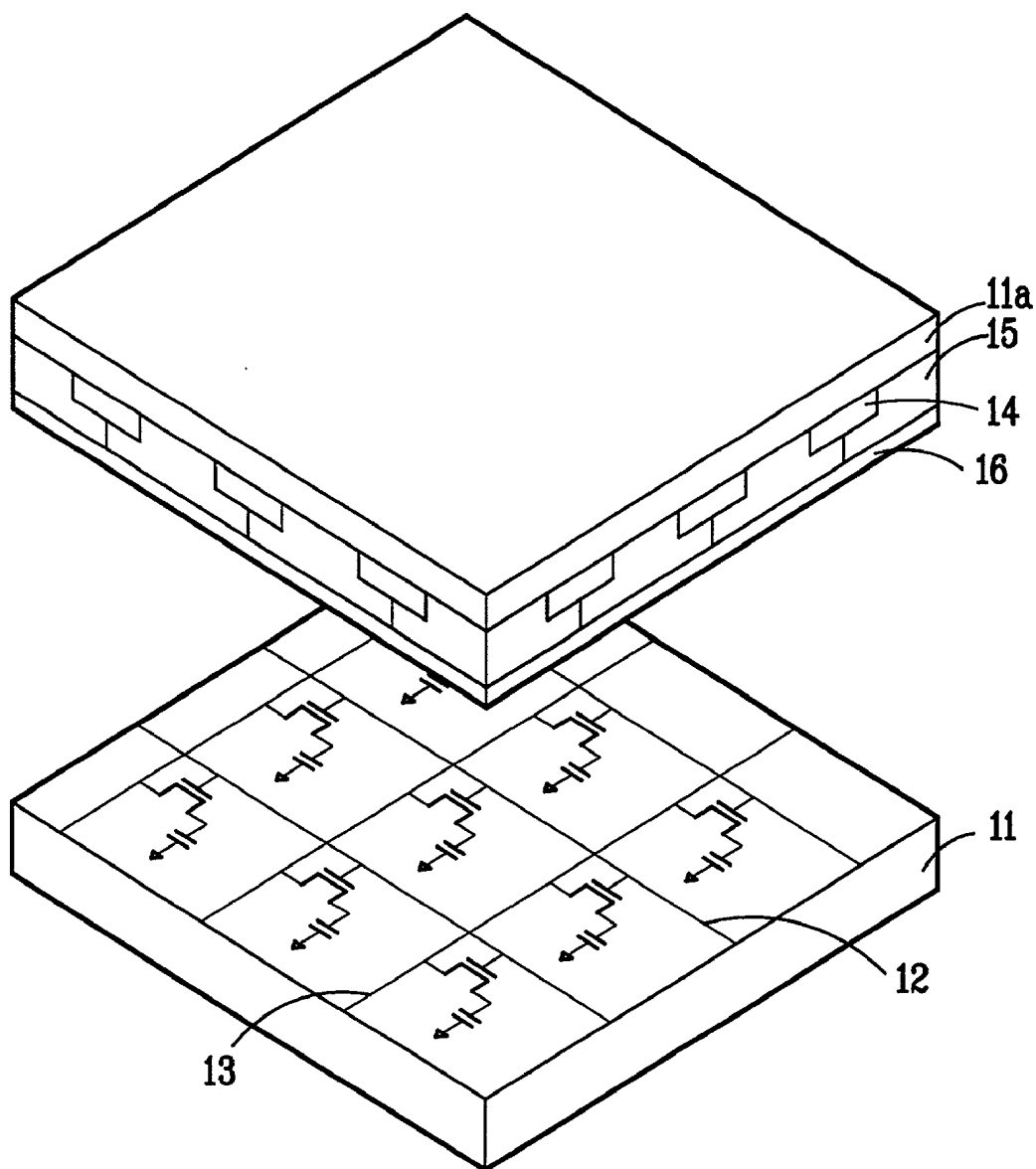

FIG. 3
Related Art

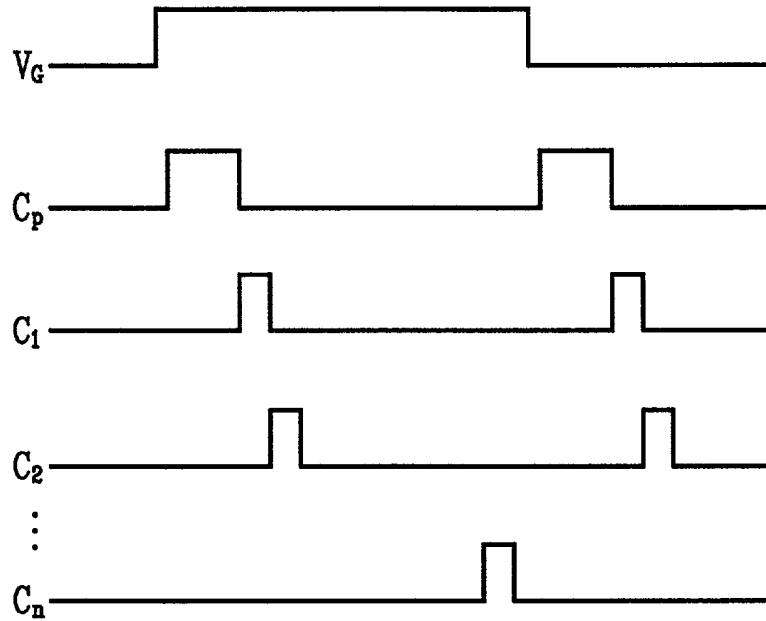

FIG. 4
Related Art

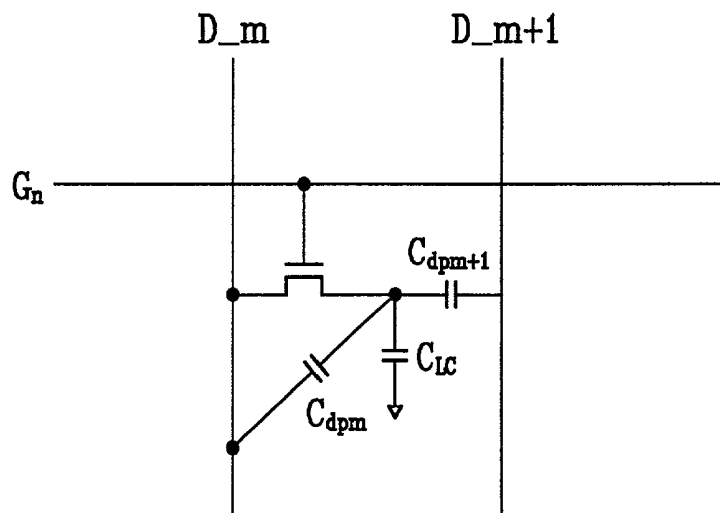

FIG. 5

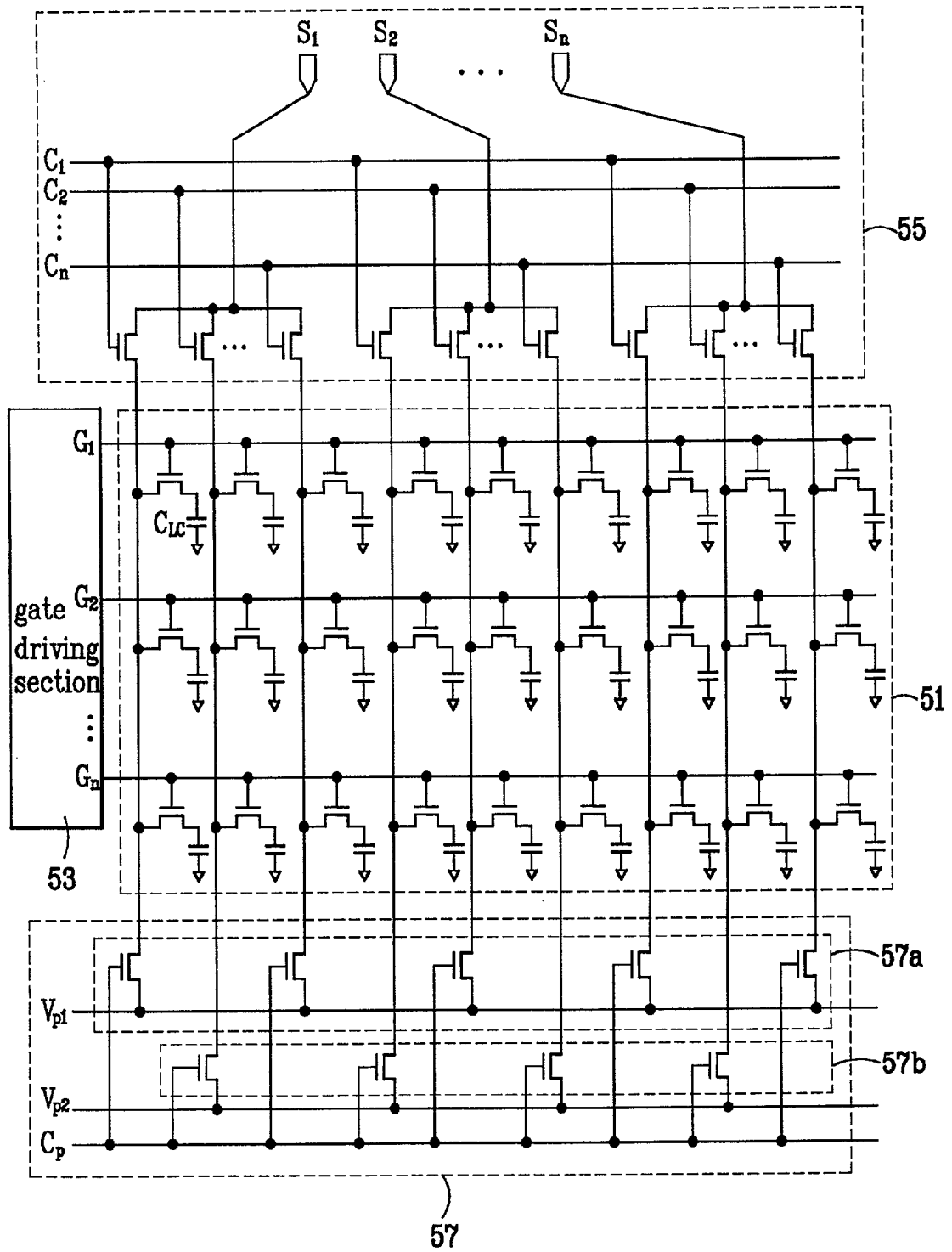
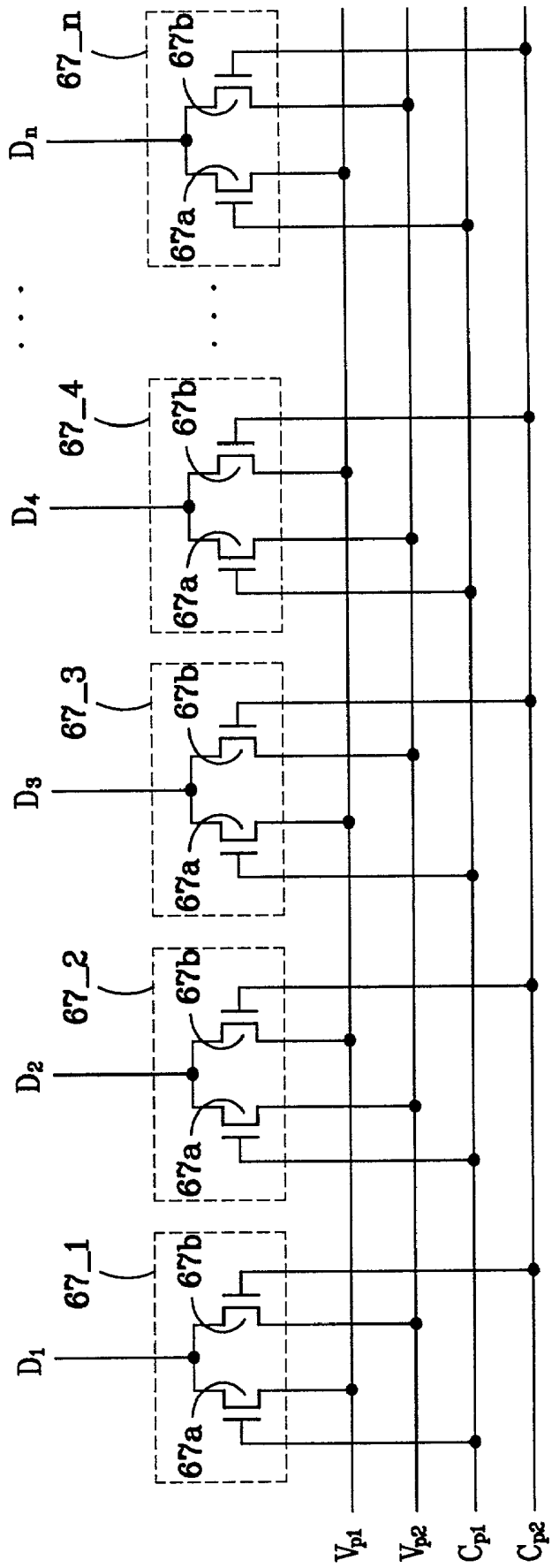

FIG. 6



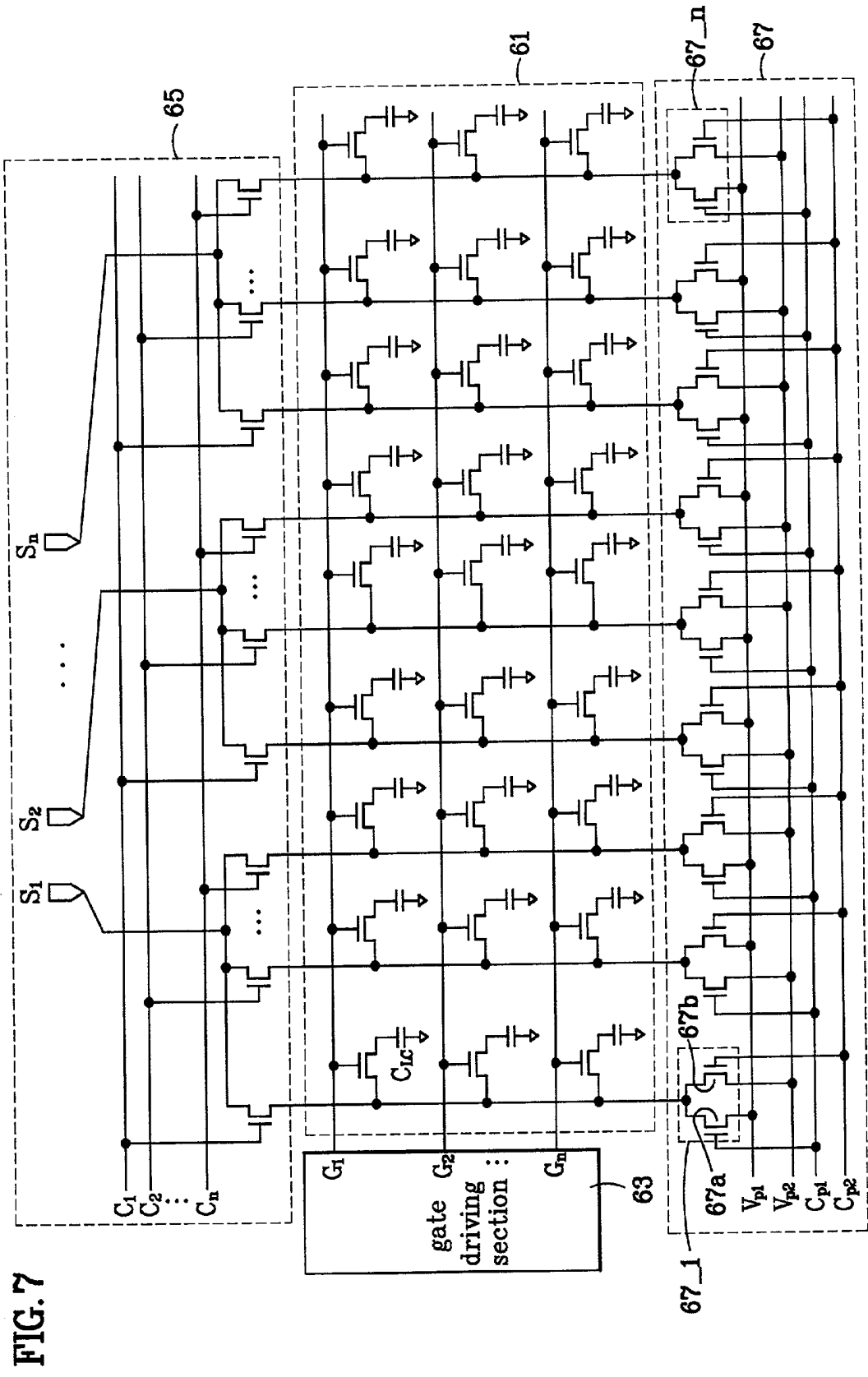

FIG. 7

FIG. 8A

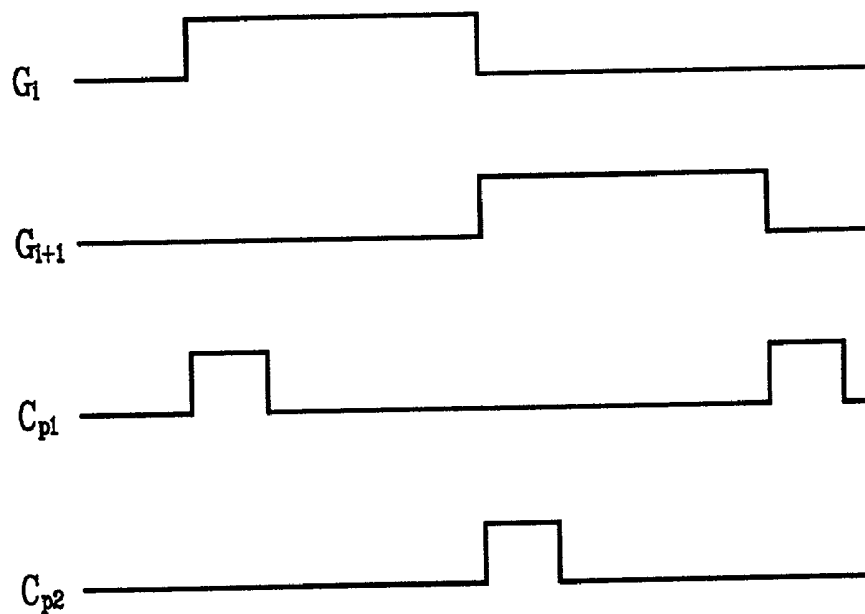

FIG. 8B

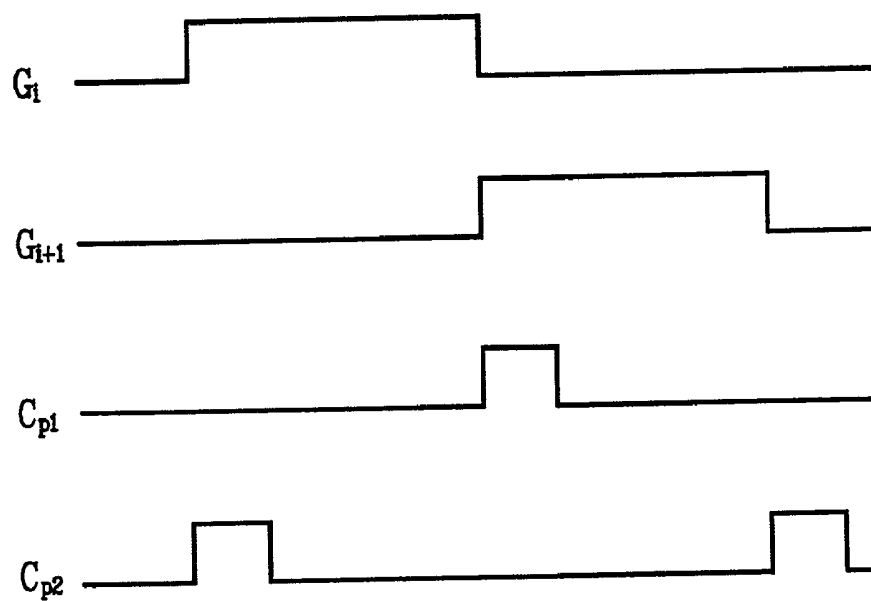
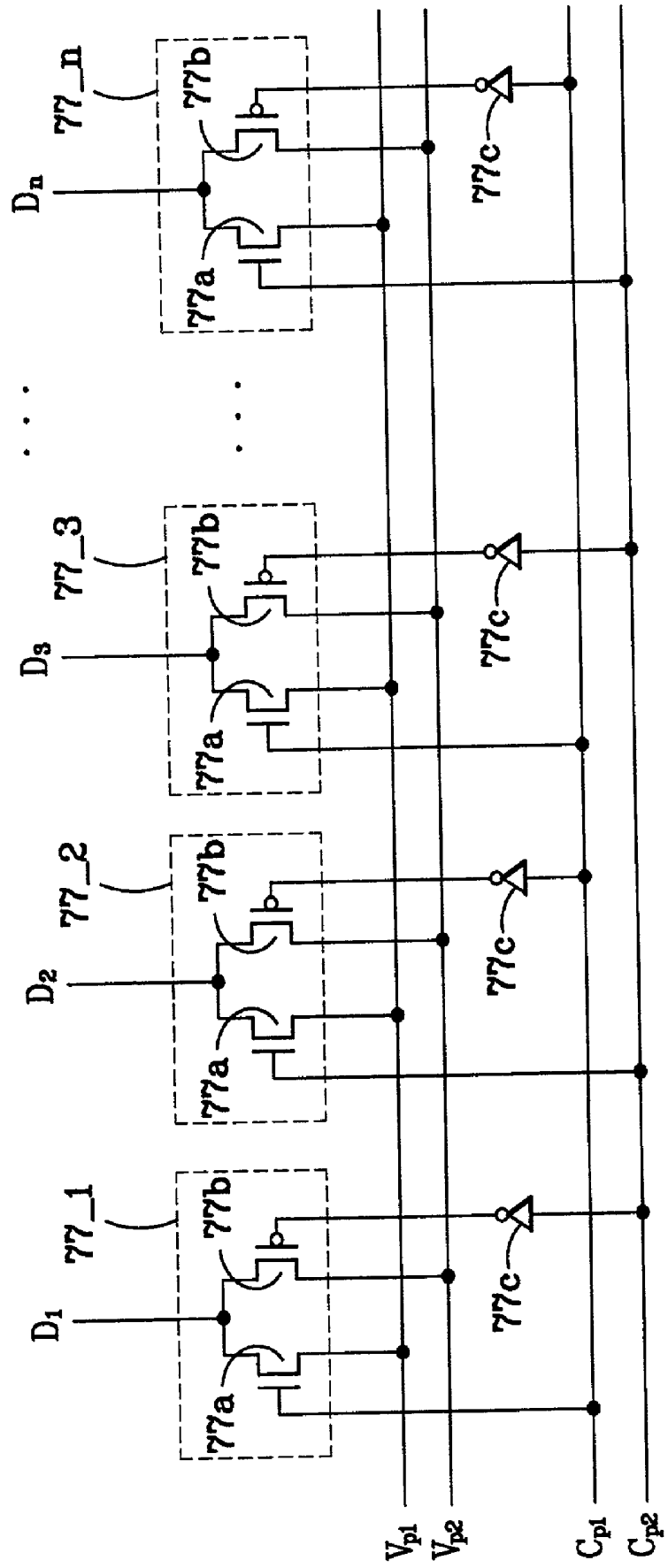

FIG. 9



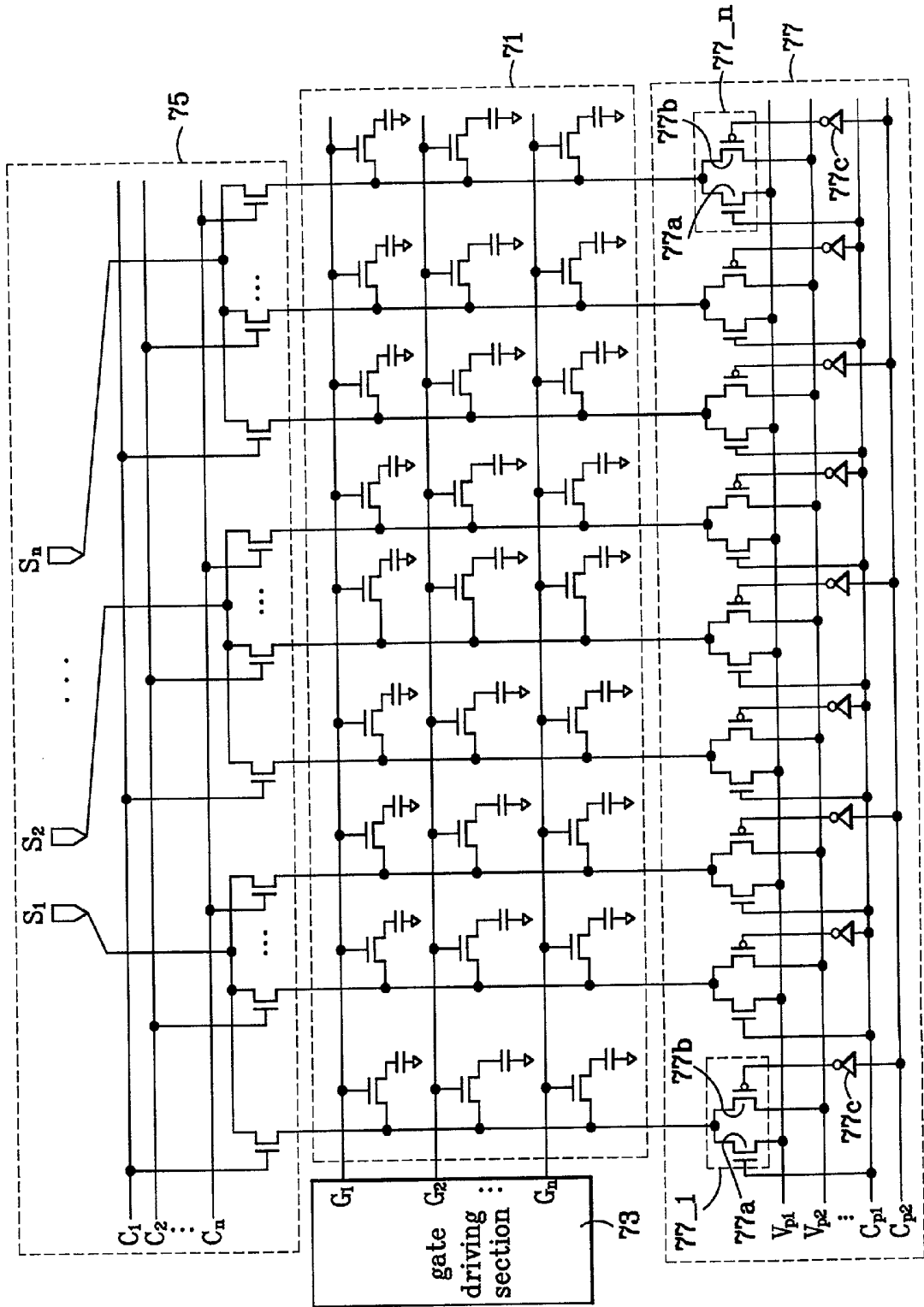

FIG.10

FIG. 11A

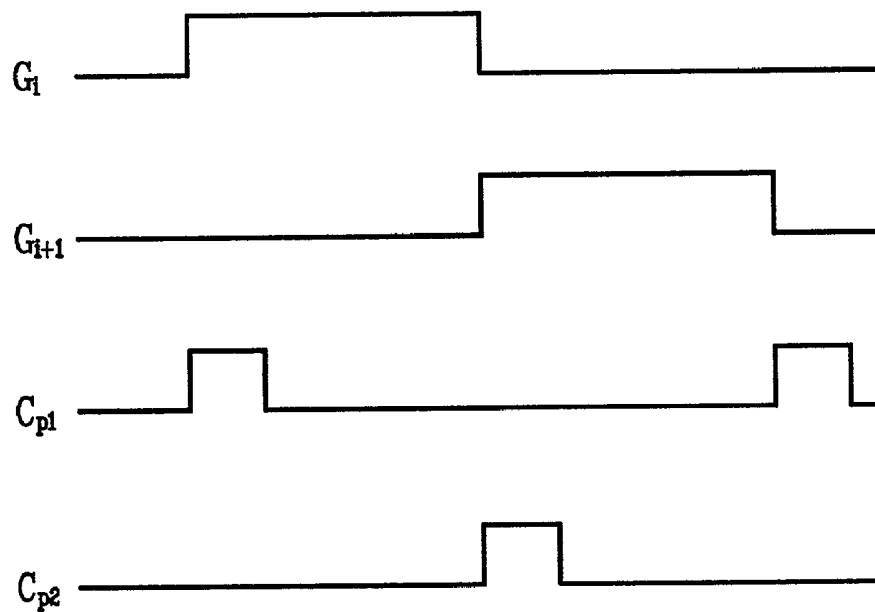
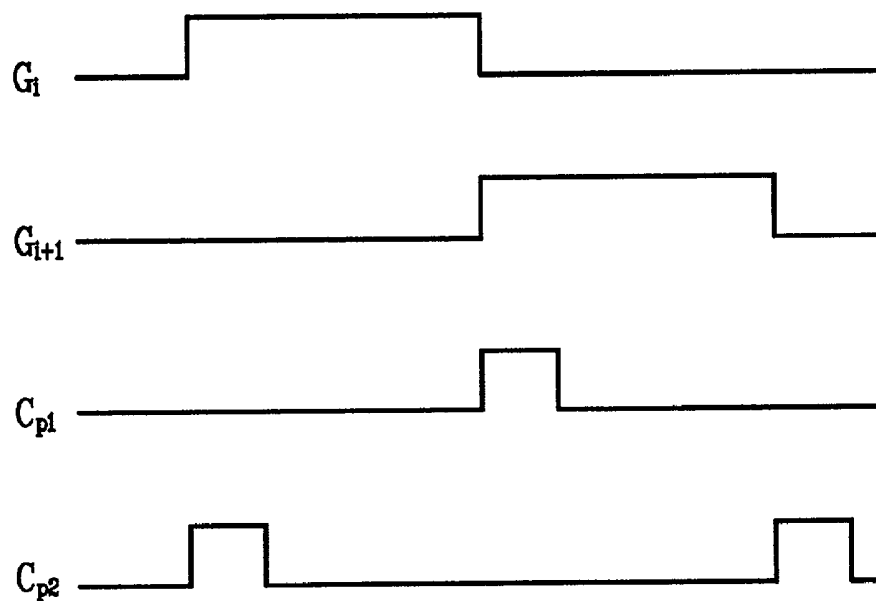

FIG. 11B



LIQUID CRYSTAL DISPLAY DEVICE AND METHOD FOR DRIVING THE SAME

[0001] The present invention claims the benefit of Korean Patent Application No. P 2000-50770 filed in Korea on Aug. 30, 2000, which is hereby incorporated by reference.

BACKGROUND OF THE INVENTION

[0002] 1. Field of the Invention

[0003] The present invention relates to a flat display device, and in particular, to a liquid crystal display (LCD) device and a method for driving the same with enhanced screen quality and reduced cross-talk effect.

[0004] 2. Description of the Related Art

[0005] In general, an LCD device is manufactured by facing two glass substrates (also called top and bottom plates) and injecting liquid crystal in the space between the two glass substrates. A data line and a gate line are arranged in a matrix form at the bottom plate to define a plurality of pixel regions. A thin film transistor and a pixel electrode are aligned in each pixel region.

[0006] Provided at the top plate are a common electrode for applying a common voltage to the liquid crystal, and a color filter layer for expressing colors of red, green and blue (R, G, B).

[0007] The following is a detailed description of various components formed on the bottom plate and the top plate.

[0008] As shown in FIG. 1, a plurality of gate lines 12 are formed on a transparent substrate 11 made of glass or quartz, and a plurality of data lines 13 are formed in a direction crossing the gate lines 12. A pixel region is defined by each data line 13 and gate line 12. A pixel electrode is aligned in the pixel region, and a thin film transistor is formed at a point where the data line 13 crosses the gate line 12.

[0009] A black matrix layer 14 is formed in a net shape on a transparent substrate 11a for shielding penetration of light to various portions of the device except the pixel electrode formed on the bottom plate. A color filter layer 15 is formed between each black matrix to express colors. A common electrode 16 is formed throughout the surface of the transparent substrate 11a including the color filter layer 15 and the black matrix layer 14.

[0010] The following is a description of a conventional LCD device made with reference to the accompanying drawings.

[0011] FIG. 2 is a diagram illustrating a panel structure of a conventional LCD device, in which a driving circuit section is integrated with a pixel section.

[0012] Referring to FIG. 2, the conventional LCD device includes a pixel section 21 having a plurality of gate lines and a plurality of data lines arranged to cross each other and a plurality of pixels having thin film transistors and liquid crystal capacitors formed at each crossing point. A gate driving circuit section 23 applies driving signals to the gate lines in order. A source driving circuit section 25 including a plurality of data line sets applies video signals to each set of data lines. A precharge circuit section 27 precharges the data lines.

[0013] The precharge circuit section 27 includes a switching section 27a composed of a precharging voltage terminal V_p and transistors for connecting each data line. The data lines are precharged a predetermined level by means of precharge control signals C_p applied to the transistor gates.

[0014] The source driving circuit section 25 includes a plurality of data line sets, each set being composed of n number of data lines. Video signal lines S_1, S_2, \dots, S_n are connected to each set of data lines so that the video signals are applied to the corresponding set of data lines by means of n number of control signals C_1, C_2, \dots, C_n .

[0015] A driving method of the conventional LCD device constructed as discussed above will now be described with reference to FIG. 3 illustrating a driving waveform.

[0016] If a gate driving signal is applied as shown in FIG. 3, the precharge circuit section 27 precharges each data line to a predetermined level with an intermediate voltage between a positive field and a negative field of the video signals.

[0017] Thereafter, each set of data lines of the source driving circuit section 25 is activated, thereby applying the video signals to the data lines. Here, the control signals C_1, C_2, \dots, C_n are activated in order. When the control signals C_1 is activated, the other control signals C_2, C_3, \dots, C_n remain inactive. When C_1 becomes inactive, the control signal C_2 changes to an active state.

[0018] Each set of data lines become active through the above process, and video signals are thus applied to the corresponding data lines.

[0019] Assuming that the video signals in a positive field have a voltage range of about 6-10 V and the video signals in a negative field have a voltage range of about 1-5 V, the data lines are precharged to a voltage level of about 5.5 V.

[0020] When the control signal C_1 changes to an inactive state and the control signal C_2 changes to an active state after the corresponding data lines are applied with video signals, a parasitic capacitance is generated because the video signals are applied to the data lines in order.

[0021] The parasitic capacitance causes distortion of the video signals applied to the data lines. Therefore, if the control signals C_n become active, the video signals applied to the corresponding data line are significantly distorted.

[0022] Such a distortion of the video signals is attributable to the parasitic capacitance generated between the two data lines adjacent to a given liquid crystal capacitor. Thus, it is crucial to reduce the parasitic capacitance. However, reduction of the parasitic capacitance has a limit as it is closely related to an aperture rate. This effect will now be described with reference to FIG. 4.

[0023] FIG. 4 is a diagram illustrating the generation of the parasitic capacitance between two adjacent data line and a liquid crystal capacitor between them in the conventional LCD device and the driving method.

[0024] Referring to FIG. 4, a capacitance is generated between the data lines adjacent to the liquid crystal capacitor within a pixel. To be specific, if a video signal is applied to an m^{th} data line D_m and then to an $m+1^{\text{th}}$ data line D_{m+1} , a coupling is generated due to a parasitic capacitance C_{dpm} between the liquid crystal capacitor C_{LC} and the m^{th} data

line. The coupling is also generated due to a parasitic capacitance $C_{\text{dpm}+1}$ between the liquid crystal capacitor C_{LC} and the $m+1^{\text{th}}$ data line.

[0025] Thus, the conventional LCD device and its associated driving method described above pose a problem by generating a coupling, which is attributable to a parasitic capacitance between a liquid crystal capacitor and adjacent data lines due to the video signals applied to the data lines consecutively.

[0026] The coupling is shown in the form of a vertical cross talk. In other words, when there is a difference in a screen pattern, a value of the liquid crystal capacitor is changed and the coupling voltage is changed due to the parasitic capacitance, thereby reducing the screen display quality.

SUMMARY OF THE INVENTION

[0027] Accordingly, the present invention is directed to an improved liquid crystal display device and method for driving the same that substantially obviate one or more of the problems due to limitations and disadvantages of the related art.

[0028] An object of the present invention is to provide an LCD device and a method for driving the same that can improve the screen display quality and reduce cross talks by preventing the signal coupling between data lines.

[0029] Additional features and advantages of the invention will be set forth in the description which follows, and in part will be apparent from the description, or maybe learned by practice of the invention. The objectives and other advantages of the invention will be realized and attained by the structure particularly pointed out in the written description and claims hereof as well as the appended drawings.

[0030] To achieve these and other advantages and in accordance with the purpose of the present invention, as embodied and broadly described, the liquid crystal display device having a first substrate and a second substrate with liquid crystal sealed therebetween, includes: a plurality of gate lines and data lines crossing each other on the first substrate; a gate driving section for driving the gate lines; a source driving section for precharging the data lines for a first time and supplying video signals to the data lines; and a precharge circuit section for precharging the data lines for a second time.

[0031] In another aspect, a method for driving the LCD device and precharging data lines, includes: a first step of precharging the data lines by shortening all data lines and applying a first precharging voltage; and a second step of precharging the data lines by alternately applying precharging voltages lower and higher than the first precharged voltage to each data line whenever horizontal scan lines are activated.

[0032] It is to be understood that both the foregoing general description and the following detailed description are exemplary and explanatory and are intended to provide further explanation of the invention as claimed.

BRIEF DESCRIPTION OF THE DRAWINGS

[0033] The accompanying drawings, which are included to provide a further understanding of the invention and are

incorporated in and constitute a part of this specification, illustrate embodiments of the invention and together with the description serve to explain the principles of the invention. In the drawings:

[0034] **FIG. 1** is a block diagram illustrating a construction of an LCD device in general;

[0035] **FIG. 2** is a block diagram illustrating a construction of a panel of a conventional LCD device;

[0036] **FIG. 3** is a driving waveform illustrating a driving method of the conventional LCD device;

[0037] **FIG. 4** is a diagram illustrating the conventional LCD device and generation of a parasitic capacitance between data lines and a liquid crystal capacitor according to the method for driving the conventional LCD device;

[0038] **FIG. 5** is a block diagram illustrating a construction of an LCD device according to a first embodiment of the present invention;

[0039] **FIG. 6** is a block diagram illustrating a precharge circuit section of the LCD device according to a second embodiment of the present invention;

[0040] **FIG. 7** is a block diagram illustrating a construction of the LCD device according to the second embodiment of the present invention;

[0041] **FIGS. 8A and 8B** are driving waveforms illustrating a driving method of the LCD device according to the second embodiment of the present invention;

[0042] **FIG. 9** is a block diagram illustrating a construction of the precharge circuit section of the LCD device according to a third embodiment of the present invention;

[0043] **FIG. 10** is a block diagram illustrating a construction of the LCD device according to the third embodiment of the present invention; and

[0044] **FIGS. 11A and 11B** are driving waveforms illustrating a driving method of the LCD device according to the third embodiment of the present invention.

DETAILED DESCRIPTION OF THE PREFERRED EMBODIMENTS

[0045] Reference will now be made in detail to the preferred embodiments of the present invention, examples of which are illustrated in the accompanying drawings.

[0046] In the following description, functions or constructions well known to those skilled in the art are not described in detail since they would obscure the invention in unnecessary detail.

First Embodiment

[0047] **FIG. 5** is a block diagram illustrating a construction of an LCD device according to a first embodiment of the present invention.

[0048] Referring to **FIG. 5**, an LCD device comprises a pixel section **51** including a plurality of gate lines $G1, G2, \dots, Gn$ and data lines $D1, D2, \dots, Dn$ arranged to cross each other and a plurality of thin film transistors (TFTs) and liquid crystal capacitors C_{LC} formed at each crossing point, a gate driving section **53** for applying driving signals to the gate lines in order, a source driving section **55** for applying

video signals $S1, S2, \dots, Sn$ to each set of data lines in order, and a precharge circuit section **57** for supplying different precharging voltages to adjacent data lines.

[0049] Here, the precharge circuit section **57** comprises first precharging voltage terminals $Vp1$, second precharging voltage terminals $Vp2$, a first switching section **57a** for switching the voltage of the first precharging voltage terminals $Vp1$ with odd number data lines $D1, D3, D5, \dots$, and a second switching section **57b** for switching the voltage of the second precharging voltage terminals $Vp2$ with even number data lines $D2, D4, D6, \dots$.

[0050] Each set of the data lines are switched with the corresponding video signal lines by the thin film transistors. For instance, the first set of data lines is switched with the video signal line $S1$, while the second set of data lines is switched by the video signal line $S2$. Here, the switchability between the data lines and the video signal lines is determined by the switching control signals $C1, C2, \dots, Cn$.

[0051] Meanwhile, the source driving section **55** includes video signal lines corresponding to each set of data lines. Video signal line can be connected (shorted) to or separated from one another by an external control.

[0052] If the video signal lines are shorted to one another before applying the video signals to the data lines, all the data lines within the pixel section **51** are shorted to one another.

[0053] If a precharging voltage of a pre-selected level is applied to the shorted video signal lines, all the data lines are precharged to the pre-selected level.

[0054] For that purpose, it is necessary to use a voltage applying section (not shown in the drawing) to apply a precharging voltage of a pre-selected level to the shorted video signal lines.

[0055] The first switching section **57a** and the second switching section **57b** include thin film transistors, and their operations are determined by precharge control signals Cp . The first precharge section **57a** and the second precharge section **57b** may use the same or different precharge control signals for their operation.

[0056] The following is a description of a driving method of the LCD device according to the first embodiment of the present invention constructed as above.

[0057] To precharge the data lines initially, the switching control signals $C1, C2, \dots, Cn$ are concurrently activated to electrically connect the data lines and video signal lines $S1, S2, \dots, Sn$.

[0058] After shorting the video signal lines $S1, S2, \dots, Sn$ to one another, a precharging voltage of a predetermined level is applied thereto. As a result, all the data lines are precharged to the predetermined level. Here, the precharging voltage of the predetermined level should be an intermediate level. For instance, assuming that the voltage of the video signals in a positive field is ranged 6-10 V and the voltage of the video signals in a negative field is ranged 1-5 V (the voltage range varies depending on the type of liquid crystal used), the precharging voltage of the predetermined level should be about 5.5 V.

[0059] After shorting the video signal lines $S1, S2, \dots, Sn$ of the source driving section **55** together and first

precharging the data lines by applying a voltage of a predetermined level, the data lines are electrically isolated from the video signal lines $S1, S2, \dots, Sn$ by deactivating the switching control signals $C1, C2, \dots, Cn$.

[0060] Thereafter, the data lines are secondly precharged by using the precharge circuit section **57**. Since the data lines are precharged at about 5.5 V, the voltage of the first precharging voltage terminals $Vp1$ is adjusted to be about 2-3 V and the voltage of the second precharging voltage terminals is adjusted to be about 7-8 V in a positive field.

[0061] In other words, if the first gate line $G1$ and the switching control signals $C1, C2, \dots, Cn$ are activated after precharging the odd number data lines to about 2-3 V and the even number data lines to about 7-8 V, video signals are loaded on the even number data lines in a positive field. The video signals are loaded on the odd number data lines in a negative field.

[0062] Therefore, assuming that the voltage of the video signals is about 6-10 V in a positive field, the voltage variation ΔV of the even number data lines is merely about 2-3 V. Assuming that the voltage of the video signals is about 1-5 V in a negative field, the voltage variation ΔV of the odd number data lines is merely about 2-3 V as well.

[0063] In order to store the video signals at a corresponding pixel by activating the second gate line, the voltage of the first precharging voltage terminals $Vp1$ should be switched with the voltage of the second precharging voltage terminals $Vp2$.

[0064] The reason is because most LCD devices employ a dot inversion method, and polarities of the video signals are reversed whenever the gate lines are activated. Accordingly, it is necessary to switch the voltages between the first precharging voltage terminals $Vp1$ and the second precharging voltage terminals $Vp2$. The voltage switch can be performed by a switching operation with a simple control signal.

[0065] In short, according to the first embodiment of the present invention, the video signals $S1, S2, \dots, Sn$ are first shorted to one another. Thereafter, the data lines are first precharged. Then, the data lines are secondly precharged by using the precharge circuit section. Therefore, the voltage variation range can be drastically narrowed in the data lines, thereby eliminating cross talks among the adjacent data lines. As a result, it is possible to prevent distortion of signals caused by voltage variation of the data lines.

Second Embodiment

[0066] The second embodiment of the present invention has a modified construction of the precharge circuit section. The precharge circuit section according to the second embodiment of the present invention has a switching element for switching the precharging voltage in a positive field and a switching element for switching the precharging voltage in a negative field connected in parallel with respect to each data line.

[0067] The second embodiment of the invention does not require any external switches for switching voltages between the first precharging voltage terminals and the second precharging voltage terminals even if the polarities of the video signals loaded on each data line are reversed as each gate line is activated.

[0068] FIG. 6 is a block diagram illustrating a precharge circuit section of the LCD device according to a second embodiment of the present invention.

[0069] Referring to FIG. 6, the precharge circuit section 67 includes switching sections 67_1, 67_2, . . . , 67_n connecting first switching elements 67a and second switching elements 67b to each data line. The first and second switching elements 67a and 67b have output terminals connected in common, but with different input sources.

[0070] In the odd number data lines, either the first precharging voltage Vp1 is applied through the first switching elements 67a in accordance with the first precharge control signal Cp1, or the second precharging voltage Vp2 is applied through the second switching elements 67b in accordance with the second precharge control signal Cp2.

[0071] In the even number data lines, either the second precharging voltage Vp2 is applied through the first switching elements 67a in accordance with the first precharge control signal Cp1, or the first precharging voltage Vp1 is applied through the second switching elements 67b in accordance with the second precharge control signal Cp2.

[0072] Here, the voltage of the first precharging voltage terminals Vp1 is ranged to be about 2-3 V, while the voltage of the second precharging voltage terminals Vp2 is ranged to be about 7-8 V. (However, the voltage ranges vary depending on the kind of liquid crystal used.)

[0073] FIG. 7 is a block diagram illustrating a construction of the LCD device according to the second embodiment of the present invention.

[0074] Referring to FIG. 7, the LCD device includes a pixel section 61 composed of a plurality of gate lines G1, G2, . . . , Gn and data lines D1, D2, . . . , Dn crossing each other to have thin film transistors TFTs and liquid crystal capacitors C_{LC} formed at each crossing point, a gate driving section 63 for applying driving signals to the gate lines in order, a source driving section 65 for applying video signals S1, S2, . . . , Sn to each set of data lines in order, and a precharge circuit section 67 connected to each data line for alternating the precharging voltages of high level and low level so that the voltages are switched with each data line.

[0075] Here, the precharge circuit section 67 includes first precharging voltage terminals Vp1 and second precharging voltage terminals Vp2 for alternately applying either one of the voltages of the first precharging voltage terminals Vp1 and the second precharging voltage terminals Vp2 to a data line in accordance with the first precharge control signals Cp1 and the second precharge control signal Cp2. The odd number data line and the even number data line are precharged with different voltages.

[0076] The precharge circuit section 67 includes switching sections 67_1, 67_2, . . . , 67_n each composed of the first switching elements 67a and the second switching elements 67b connected in parallel to each data line. The switching elements are composed of thin film transistors of an identical conductive type.

[0077] Each set of data lines are connected to the corresponding video signal line by the thin film transistors. For instance, the first set of data lines are connected to the video signal line S1, while the second set of data lines are connected to the video signal line S2. Here, the connection

between the data lines and the video signal lines is determined by the switching control signals C1, C2, . . . , Cn.

[0078] The source driving section 65 includes the video signal lines S1, S2, . . . , Sn corresponding to the sets of data lines. Each video signal line can be connected together (i.e., shorted to one another) or separated by an external control.

[0079] Accordingly, if the video signal lines are shorted to one another before applying the video signals to the data lines, the respective data lines within the pixel section 61 become shorted together.

[0080] Here, if a precharging voltage of a predetermined level is applied to the shorted video signal lines, all the data lines are precharged to the predetermined level.

[0081] To this end, a precharging voltage applying section (not shown in the drawing) is used for applying the precharging voltage of a predetermined level to the shorted video signal lines.

[0082] Here, the high-level precharging voltage is higher than the voltage precharged by the source driving section, while the low-level precharging voltage is lower than the voltage precharged by the source driving section.

[0083] The following is a description of a driving method of the LCD device according to the second embodiment of the present invention.

[0084] To first precharge the data lines, the switching control signals C1, C2, . . . , Cn are simultaneously activated, and the data lines are electrically connected to the video signal lines S1, S2, . . . , Sn.

[0085] Then, the video signals S1, S2, . . . , Sn are shorted to one another, and a precharging voltage of a predetermined level is applied thereto so that all the data lines can be precharged to the predetermined level. Here, the precharging voltage of the predetermined level should be an intermediate voltage between the voltage of the video signals in a positive field and the voltage of the video signals in a negative field. For instance, assuming that the voltage of the video signals in a positive field is ranged 6-10 V and the voltage of the video signals in a negative field is ranged 1-5 V, the precharging voltage of the predetermined level should be about 5.5 V.

[0086] After shorting the video signals S1, S2, . . . , Sn of the source driving section 65 to one another, the data lines are first precharged by applying the precharging voltage of the predetermined level. Subsequently, the switching control signals C1, C2, . . . , Cn are deactivated to electrically isolate the data lines from the video signal lines S1, S2, . . . , Sn.

[0087] Then, the data lines are secondly precharged by using the precharging circuit 67. For reference, the data lines are currently in a precharged state at about 5.5 V.

[0088] The voltage of the first precharging voltage terminals Vp1 is fixed to be about 2-3 V, and the voltage of the second precharging voltage terminals Vp2 is fixed to be about 7-8 V.

[0089] If the first precharge control signals Cp1 are activated thereafter, the odd number data lines are precharged with the voltage of the first precharging voltage terminals Vp1, while the even number data lines are precharged with the voltage of the second precharging voltage terminals Vp2.

[0090] If the first gate line and the switching control signals C1, C2, . . . , Cn are activated at this stage, the video signals are loaded on the even number data lines precharged at about 7-8 V in a positive field, and the video signals are loaded on the odd number data lines precharged at 2-3 V in a negative field.

[0091] Therefore, assuming that the voltage of the video signals is about 6-10 V in a positive field, the voltage variation of the even number data lines is merely about 2-3 V. Assuming that the voltage of the video signals is 1-5 V in a negative field, the voltage variation of the odd number data lines is merely about 2-3 V as well.

[0092] In order to activate the second gate line and the switching control signals C1, C2, . . . , Cn and to transfer video signals to the corresponding pixel electrode, the first precharge control signals Cp1 are inactivated, and the second precharge control signals Cp2 are activated as shown in FIG. 8A.

[0093] Accordingly, the odd number data lines are precharged at the voltage of the second precharging voltage terminals Vp2, while the even number data lines are precharged at the voltage of the first precharging voltage terminals Vp1.

[0094] Here, the video signals are loaded on the odd number data lines precharged at the voltage of about 7-8 V in a positive field, and the video signals are loaded on the even number data lines precharged at the voltage of about 2-3 V.

[0095] In short, assuming that the voltage of the video signals is 6-10 V in a positive field, the voltage variation of the even number data lines is merely about 2-3 V. Assuming that the voltage of the video signals is about 1-5 V in a negative field, the voltage variation of the odd number data lines is merely about 2-3 V as well.

[0096] Further, activation timing of the first precharge control signals Cp1 is switched with that of the second precharge control signal Cp2. The first precharge control signal Cp1 and the second precharge control signal Cp2 are alternately activated for every horizontal scan line (gate line) as shown in FIGS. 8A and 8B.

[0097] According to the second embodiment of the present invention as described above, the video signals S1, S2, . . . , Sn are shorted to one another to first precharge the data lines. The data lines are then secondly precharged by means of the precharge circuit section. Therefore, voltage variation range in the data lines is drastically narrowed, thereby reducing the cross-talks among the adjacent data lines.

Third Embodiment

[0098] The third embodiment of the present invention has a further modified construction of the precharge circuit section. The precharge circuit section according to the second embodiment employs the first switching element and the second switching element that are commonly connected to the data lines and composed of thin film transistors of an identical conductive type. In comparison, the precharging circuit section according to the third embodiment employs the first switching element and the second switching element composed of film transistors of opposite conductive types.

[0099] FIG. 9 is a block diagram illustrating a construction of the precharge circuit section of the LCD device according to the third embodiment of the present invention. FIG. 10 is a block diagram illustrating a construction of the LCD device employing the precharge circuit section in FIG. 9 according to the third embodiment of the present invention.

[0100] The precharge circuit section according to the third embodiment of the present invention includes switching sections 77_1, 77_2, . . . , and 77-n, each connected to a data line and comprising first switching elements 77a formed of thin film transistors of an N conductive type and second switching elements 77b formed of thin film transistors of a P conductive type.

[0101] Here, the first switching elements 77a connected to the odd number data lines switch the voltage of the first precharge voltage terminals Vp1 by means of the first precharge control signal Cp1, while the second switching elements 77b switch the voltage of the second precharge voltage terminals vp2 by means of an inversion signal of the second precharge control signal Cp2.

[0102] The first switching elements 77a connected to the even number data lines switch the voltage of the first precharge voltage terminals Vp1 by means of the second precharge control signal Cp2, while the second switching elements 77b switch the voltage of the second precharge voltage terminals Vp2 by means of an inversion signal of the first precharge control signal Cp1.

[0103] Here, the second switching elements 77b connected to each data line receive output signals of inverters 77c, which invert the corresponding precharge control signal.

[0104] The first switching elements 77a are composed of thin film transistors of an N conductive type, while the second switching elements 77b are composed of thin film transistors of a P conductive type.

[0105] The precharge circuit section described above applies a high precharging voltage in a positive field, by means of the thin film transistors of a P conductive type, and a low precharging voltage in a negative field, by means of the thin film transistors of an N conductive type.

[0106] Thus, the size of the thin film transistors can be optimized and the driving voltage can be subsequently lowered by selectively using the thin film transistors of a P conductive type and an N conductive type according to the respective voltage level.

[0107] FIG. 10 is a block diagram illustrating a construction of the LCD device employing the precharge circuit section in FIG. 9 according to the third embodiment of the present invention.

[0108] Referring to FIG. 10, the LCD device according to the third embodiment includes a pixel section 71 having a plurality of gate lines G1, G2, . . . , Gn and data lines D1, D2, . . . , Dn crossing each other to have thin film transistors TFTs and liquid crystal capacitors C_{LC} formed at each crossing point, a gate driving section 73 for applying driving signals to the gate lines in order, a source driving section 75 for applying video signals S1, S2, . . . , Sn to each set of data lines in order, and a precharge circuit section 77 including first precharging voltage terminals Vp1 and second pre-

charging voltage terminals **Vp2**, and switching sections (not shown) for switching a high precharging voltage in a positive field with a low precharging voltage in a negative field for each data line by means of separate switching elements.

[0109] Here, the odd number data lines and the even number data lines are precharged with different voltages.

[0110] The precharge circuit section **71** includes switching sections **77_1**, **77_2**, . . . , **77_n** each composed of first switching elements **77a** and second switching elements **77b** connected in parallel for each data line. The switching elements are composed of thin film transistors of opposite conductive types.

[0111] Here, the first switching elements **77a** are thin film transistors of an N conductive type, while the second switching elements **77b** are thin film transistors of a P conductive type. The second switching elements **7b** are operated by output signals of inverters **77c**, which invert the corresponding precharge control signals.

[0112] Each set of data lines are connected to the corresponding video signal lines by the film transistors. For instance, the first set of data lines are connected to the video signal line **S1**, while the second set of data lines are connected to the video signal line **S2**. Here, the connection between the data lines and the video signal lines is determined by the switching control signals **C1**, **C2**, . . . , **Cn**.

[0113] Meanwhile, the source driving section **75** comprises video signal lines **S1**, **S2**, . . . , **Sn** corresponding to each set of data lines. Each video signal line can be shorted or disconnected from one another by an external control.

[0114] If the video signal lines are shorted from one another before applying the video signals to the data lines, all the data lines within the pixel section **71** are shorted to one another.

[0115] If a precharging voltage of a predetermined level is applied to the shorted video signal lines, all the data lines are precharged to the predetermined level.

[0116] For that purpose, a voltage applying section (not shown in the drawing) is used to apply a precharging voltage of a predetermined level to the shorted video signal lines.

[0117] The following is a description of a driving method of the LCD device according to the third embodiment of the present invention constructed as above.

[0118] To first precharge the data lines, the switching control signals **C1**, **C2**, . . . , **Cn** are simultaneously activated, and the data lines are electrically connected to the video signal lines **S1**, **S2**, . . . , **Sn**.

[0119] Then, the video signals **S1**, **S2**, . . . , **Sn** are shorted to one another, and a precharging voltage of a predetermined level is applied thereto so that all the data lines can be precharged to the predetermined level. Here, the precharging voltage of the predetermined level should be an intermediate voltage between the voltage of the video signals in a positive field and the voltage of the video signals in a negative field. For instance, assuming that the voltage of the video signals in a positive field is ranged 6-10 V and the voltage of the video signals in a negative field is ranged 1-5 V, the precharging voltage of the predetermined level should be about 5.5 V.

[0120] After shorting the video signals **S1**, **S2**, . . . , **Sn** of the source driving section **75** to one another, the data lines are first precharged by applying the precharging voltage of the predetermined level. Subsequently, the switching control signals **C1**, **C2**, . . . , **Cn** are deactivated to electrically isolate the data lines from the video signal lines **S1**, **S2**, . . . , **Sn**.

[0121] Then, the data lines are secondly precharged by using the precharging circuit **77**. For reference, the data lines are currently in a precharged state at about 5.5 V.

[0122] The voltage of the first precharging voltage terminals **Vp1** is fixed to be about 2-3 V, and the voltage of the second precharging voltage terminals **Vp2** is fixed to be about 7-8 V.

[0123] Thereafter, if the first precharge control signals **Cp1** are activated to a high level and the second precharge control signals **Cp2** are activated to a low level, the voltage of the first precharging voltage terminals **Vp1** is applied to the odd number data lines through the first switching elements **77a**, and the voltage of the second precharge voltage terminals **Vp2** is applied to the even number data lines through the second switching elements **77b**.

[0124] Here, if the first gate line and the switching control signals **C1**, **C2**, . . . , **Cn** are activated, video signals are loaded in the even number data lines precharged at the voltage of about 7-8 V in a positive field, and video signals are loaded in the odd number data lines precharged at the voltage of about 2-3 V in a negative field.

[0125] Therefore, assuming that the voltage of the video signals is about 6-10 V in a positive field, the voltage variation of the even number data lines is merely about 2-3 V. Assuming that the voltage of the video signals is about 1-5 V in a negative field, the voltage variation of the odd number data lines is merely about 2-3 V as well.

[0126] In order to activate the second gate line and the switching control signals **C1**, **C2**, . . . , **Cn** and to transfer video signals to the corresponding pixel electrode, the first precharge control signals **Cp1** should be deactivated to a low level, and the second precharge control signals **Cp2** should be activated to a high level.

[0127] Therefore, the voltage of the second precharging voltage terminal **Vp2** is applied to the odd number data lines through the second switching elements **77b**, and the voltage of the first precharging voltage terminal **Vp1** is applied to the even number data lines through the first switching elements **77a**.

[0128] Here, the video signals are loaded on the odd number data lines precharged at about 7-8 V in a positive field, and the video signals are loaded on the even number data lines precharged at about 2-3 V in a negative field.

[0129] Therefore, assuming that the voltage of the video signals is about 6-10 V in a positive field, the voltage variation of the even number data lines is merely about 2-3 V. Assuming that the voltage of the video signals is 1-5 V in a negative field, the voltage variation of the odd number data lines is merely 2-3 V as well.

[0130] In the third embodiment of the present invention constructed as above, activation timing of the first precharge control signals **Cp1** is switched with that of the second precharge control signal **Cp2**. Also, the first precharge

control signal Cp1 and the second precharge control signal Cp2 are alternately activated for every horizontal scan line (gate line) as shown in **FIGS. 11A and 11B**.

[0131] According to the third embodiment of the present invention, the video signal lines S1, S2, . . . , Sn are shorted to one another to first precharge the data lines. The data lines are secondly precharged by using the precharge circuit section 77. The high-level precharging voltage in a positive field is applied to the data lines by means of the thin film transistors of a P conductive type, while the low-level precharging voltage in a negative field is applied to the lines by means of the thin film transistors of an N conductive type.

[0132] As described above, the LCD device and a method for driving the same according to the present invention have the following advantages.

[0133] First, distortion of video signals caused by signal coupling between adjacent data lines can be prevented by precharging the data lines multiple times and by minimizing the range of voltage variation of the data lines.

[0134] Second, the precharging voltage required in a positive field can be more easily switched with the precharging voltage required in a negative field.

[0135] Third, size and driving voltage of the switching elements can be reduced by employing the switching elements of an optimal size according to the level of the precharging voltage.

[0136] It will be apparent to those skilled in the art that various modifications and variations can be made in the liquid crystal display device and method for driving the same of the present invention without departing from the spirit or scope of the invention. Thus, it is intended that the present invention cover modifications and variations of this invention provided they come within the scope of the appended claims and their equivalence.

What is claimed as:

1. A liquid crystal display (LCD) device having a first substrate and a second substrate with liquid crystal sealed therebetween, comprising:

- a plurality of gate lines and data lines crossing each other on the first substrate;
- a gate driving section for driving the gate lines;
- a source driving section for precharging the data lines for a first time and supplying video signals to the data lines; and
- a precharge circuit section for precharging the data lines for a second time.

2. The LCD device of claim 1, wherein the precharging for the first time is performed by shorting the plurality of data lines together and applying a first precharging voltage to the plurality of data lines.

3. The LCD device of claim 1, wherein the precharge circuit section comprises:

- a plurality of precharging voltage terminals; and
- a switching section for selectively applying a second precharging voltage from the plurality of precharging voltage terminals to a corresponding data line.

4. The LCD device of claim 3, wherein the switching section includes a transistor and is controlled by a precharge control signal.

5. An LCD device having a first substrate and a second substrate with liquid crystal sealed therebetween, comprising:

- a plurality of gate lines and data lines crossing each other on the first substrate;
- a gate driving section for driving the gate lines;
- a source driving section for precharging the data lines with a first precharging voltage and supplying video signals to the data lines; and
- a precharge circuit section for precharging the data lines by supplying different precharging voltages to adjacent data lines.

6. The LCD device of claim 5, wherein one of the different precharging voltages supplied to the adjacent data lines is lower than the first precharging voltage, and another of the different precharging voltages is higher than the first precharging voltage.

7. The LCD device of claim 5, wherein the precharge circuit section comprises:

- first precharging voltage terminals for applying a low voltage;
- second precharging voltage terminals for applying a high voltage;
- first switching sections for connecting odd number data lines and the first precharging voltage terminals; and
- second switching sections for connecting even number data lines and the second precharging voltage terminals.

8. The LCD device of claim 7, wherein the first switching section and the second switching section are operated by different precharge control signals.

9. The LCD device of claim 7, wherein the first switching section and the second switching section include thin film transistors.

10. An LCD device including a first substrate and a second substrate with liquid crystal sealed therebetween, comprising:

- a plurality of gate lines and data lines crossing each other on the first substrate;
- a source driving section for precharging the data lines with a first precharging voltage and supplying video signals to the data lines; and
- a precharge circuit section connected to each data line and comprising switching elements for alternately connecting second precharging voltage of high level and third precharging voltage of low level to the data lines.

11. The LCD device of claim 10, wherein the second precharging voltage of high level is higher than the first precharging voltage, and the third precharging voltage of low level is lower than the first precharging voltage.

12. The LCD device of claim 10, wherein adjacent data lines are precharged with voltages of different levels by the switching operation of the precharge circuit section.

13. The LCD device of claim 10, wherein the precharge circuit section further comprises:

first precharging voltage terminals for applying the third precharging voltage of low level; and

second precharging voltage terminals for applying the second precharging voltage of high level.

14. The LCD device of claim 13, wherein the voltage levels of the first precharging voltage terminals and the second precharging voltage terminals are inverted for every gate line.

15. The LCD device of claim 13, wherein the switching elements connected to odd number data lines comprise:

first thin film transistors operated by a first precharge control signal, and having sources connected to the first precharging voltage terminals and drains connected to the data lines; and

second thin film transistors operated by a second precharge control signal, and having sources connected to the second precharging voltage terminals and drains connected to the drains of the first film transistor.

16. The LCD device of claim 13, wherein the switching elements connected to even number data lines comprise:

first thin film transistors operated by a first precharge control signal, and having sources connected to the second precharging voltage terminals and drains connected to the data lines; and

second thin film transistors operated by a second precharge control signal, and having sources connected to the first precharging voltage terminals and drains connected to the drains of the first film transistor.

17. The LCD device of claim 15 or **16**, wherein the first and the second thin film transistors are of an N conductive type.

18. The LCD device of claim 13, wherein the switching elements connected to odd number data lines comprise:

first thin film transistors operated by a first precharge control signal, and having sources connected to the first precharging voltage terminals and drains connected to the data lines;

an inverter for inverting a second precharging control signal; and

second thin film transistors operated by the inverted second precharge control signal, and having sources connected to the second precharging voltage terminals and drains connected to the drains of the first film transistor.

19. The LCD device of claim 13, wherein the switching elements connected to even number data lines comprise:

first thin film transistor operated by a first precharge control signal, and having sources connected to the second precharging voltage terminals and drains connected to the data lines;

an inverter for inverting the first precharge control signal; and

second thin film transistors operated by the inverted first precharge control signal, and having sources connected to the first precharging voltage terminals and drains connected to the drains of the first film transistor.

20. The LCD device of claim 18 or **19**, wherein the first thin film transistors are of an N conductive type, and the second thin film transistors are of a P conductive type.

21. A method for driving an LCD device and precharging data lines, comprising:

a first step of precharging the data lines by shorting all data lines together and applying a first precharging voltage; and

a second step of precharging the data lines by alternately applying precharging voltages lower and higher than the first precharged voltage to each data line as horizontal scan lines are activated.

22. The method of claim 21, wherein precharging voltages of different levels are applied to adjacent data lines in the second step.

23. The method of claim 21, wherein switching elements of the same or different conductive types are used for applying the precharging voltages lower and higher than the first precharged voltage to a data line.

24. The method of claim 23, wherein the precharging voltages lower and higher than the first precharged voltage are alternately switched as horizontal scan lines are activated, if switching elements of the same conductive type are used.

25. The method of claim 23, wherein if switching elements of different conductive types are used, control signals for operating the corresponding switching elements are alternately activated.

* * * * *

专利名称(译)	液晶显示装置及其驱动方法		
公开(公告)号	US20020047820A1	公开(公告)日	2002-04-25
申请号	US09/894908	申请日	2001-06-29
[标]申请(专利权)人(译)	HA YONG MIN		
申请(专利权)人(译)	HA YONG MIN		
当前申请(专利权)人(译)	LG DISPLAY CO. , LTD.		
[标]发明人	HA YONG MIN		
发明人	HA, YONG MIN		
IPC分类号	G02F1/133 G09G3/36		
CPC分类号	G09G3/3614 G09G2320/0209 G09G2310/0248 G09G3/3648		
优先权	1020000050770 2000-08-30 KR		
其他公开文献	US6847344		
外部链接	Espacenet USPTO		

摘要(译)

一种液晶显示 (LCD) 装置，具有第一基板和其间密封有液晶的第二基板，包括在第一基板上彼此交叉的多条栅极线和数据线；栅极驱动部分，用于驱动栅极线；源驱动部分，用于第一次预充电数据线并向数据线提供视频信号；和预充电电路部分，用于第二次预充电数据线。

