



US009274390B2

(12) **United States Patent**
Chang et al.

(10) **Patent No.:** **US 9,274,390 B2**
(45) **Date of Patent:** **Mar. 1, 2016**

(54) **LIQUID CRYSTAL DISPLAY DEVICE AND FABRICATING METHOD THEREOF**

USPC 349/106, 44
See application file for complete search history.

(75) Inventors: **Youn-Gyoung Chang**, Kyonggi-do (KR); **Woong-Kwon Kim**, Kyonggi-do (KR)

(56) **References Cited**

(73) Assignee: **LG DISPLAY CO., LTD.**, Seoul (KR)

U.S. PATENT DOCUMENTS

(*) Notice: Subject to any disclaimer, the term of this patent is extended or adjusted under 35 U.S.C. 154(b) by 1733 days.

5,299,041 A *	3/1994	Morin et al.	349/42
5,818,550 A *	10/1998	Kadota et al.	349/43
5,926,702 A *	7/1999	Kwon et al.	438/158
6,038,006 A *	3/2000	Sasaki et al.	349/106
6,137,552 A *	10/2000	Yanai	349/44
6,380,559 B1 *	4/2002	Park et al.	257/59

* cited by examiner

(21) Appl. No.: **10/201,922**

Primary Examiner — Timothy L Rude

(22) Filed: **Jul. 25, 2002**

(74) *Attorney, Agent, or Firm* — Dentons US LLP

(65) **Prior Publication Data**

US 2003/0020852 A1 Jan. 30, 2003

(57) **ABSTRACT**

(30) **Foreign Application Priority Data**

Jul. 25, 2001 (KR) P2001-044757

A liquid crystal display device includes first and second substrates facing into each other, a gate line and a data line on an inner surface of the first substrate, the gate line and the data line defining a pixel region, a thin film transistor connected to the gate line and the data line, a pixel electrode connected to the thin film transistor and disposed at the pixel region, a color filter layer disposed closer than the pixel electrode from the first substrate, the color filter layer corresponding to the pixel electrode, a black matrix over the thin film transistor, a common electrode on an inner surface of the second substrate, and a liquid crystal layer interposed between the pixel electrode and the common electrode.

(51) **Int. Cl.**
G02F 1/1362 (2006.01)

(52) **U.S. Cl.**
CPC **G02F 1/136209** (2013.01); **G02F 2001/136222** (2013.01); **G02F 2201/40** (2013.01)

(58) **Field of Classification Search**
CPC G02F 1/136209

10 Claims, 13 Drawing Sheets

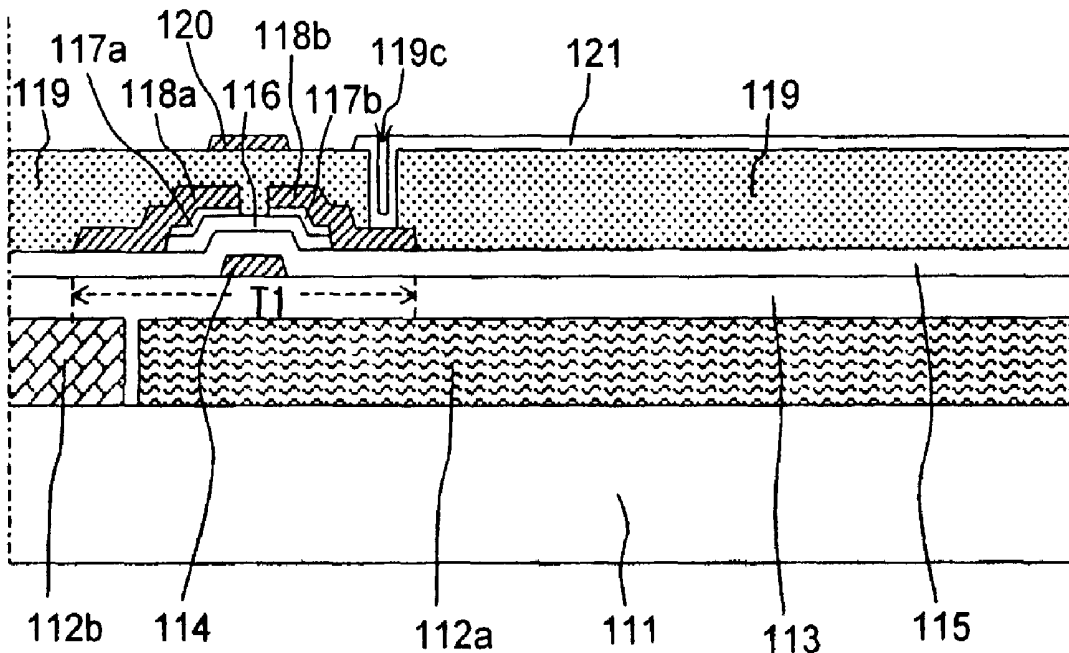

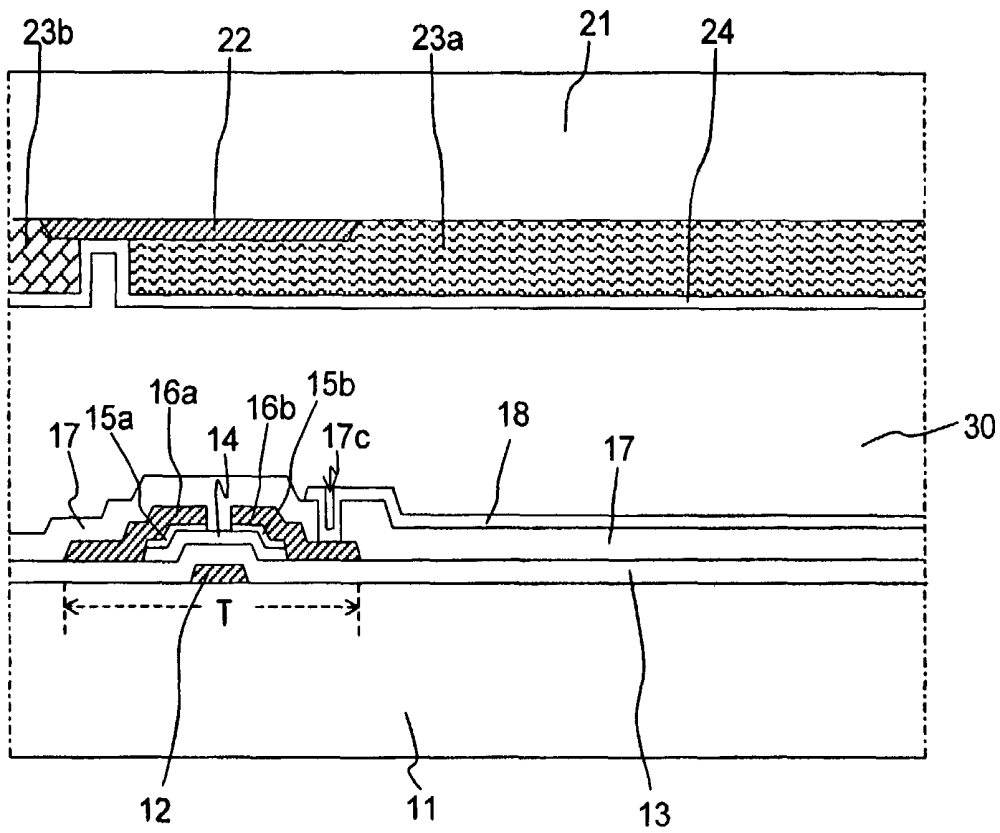

(related art)
FIG. 1

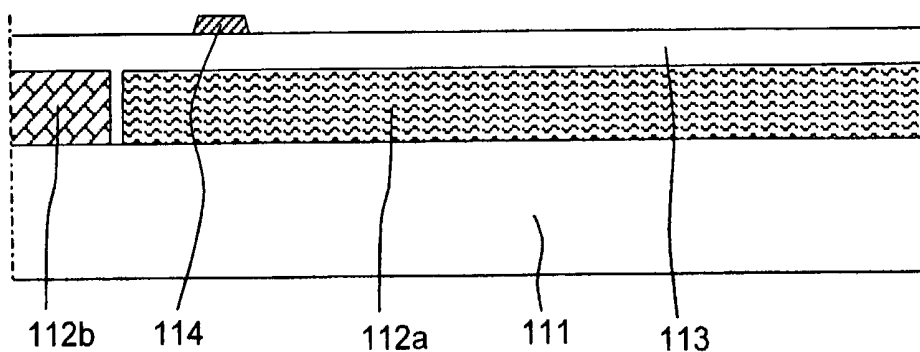

FIG. 3B

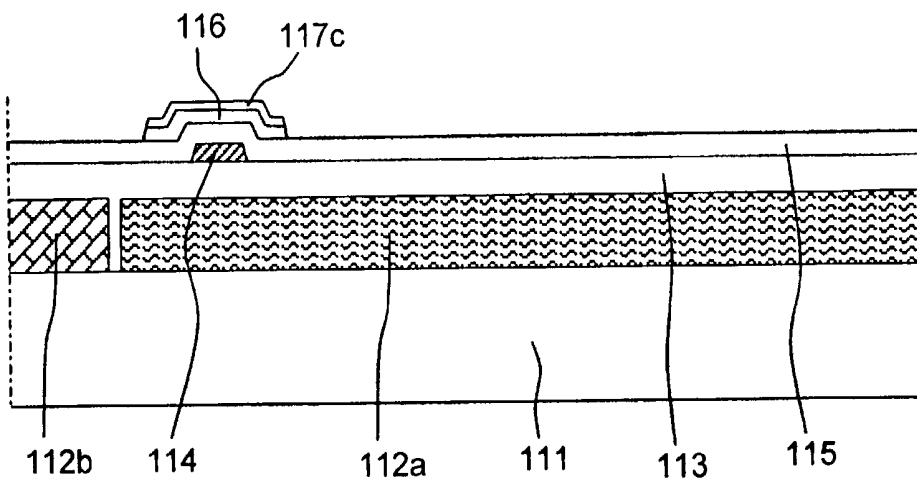

FIG. 3C

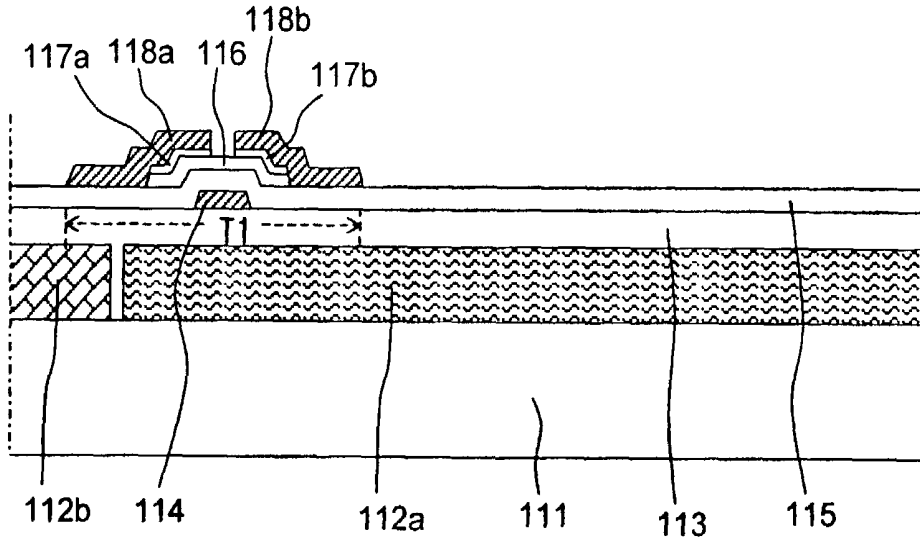

FIG. 3D

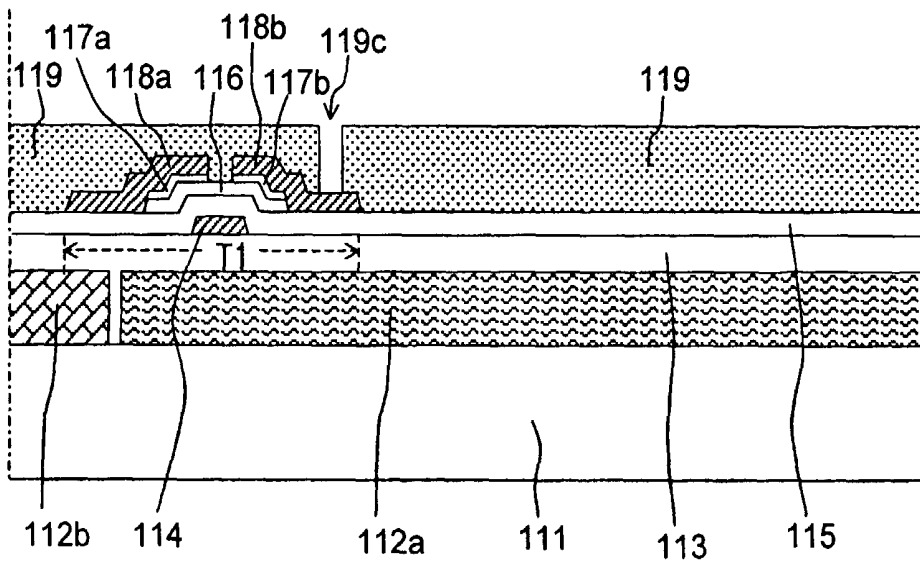

FIG. 3E

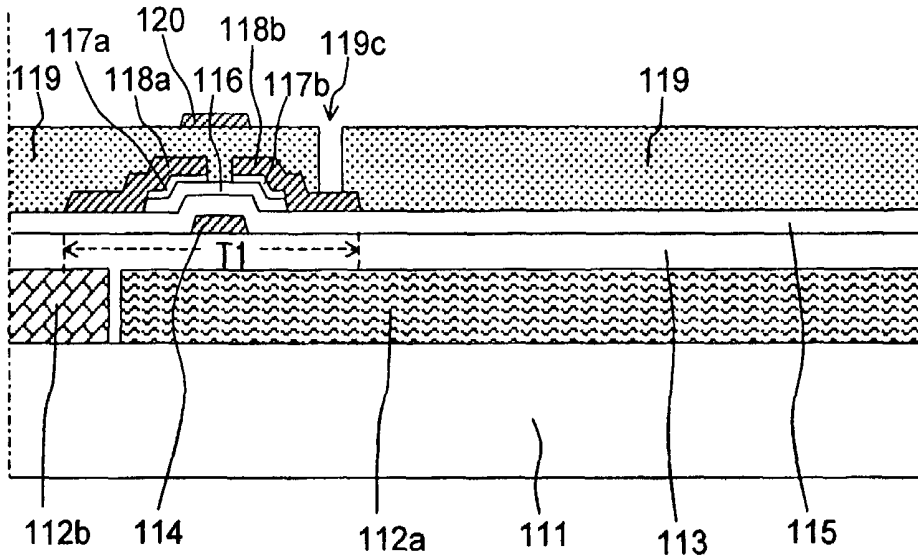

FIG. 3F

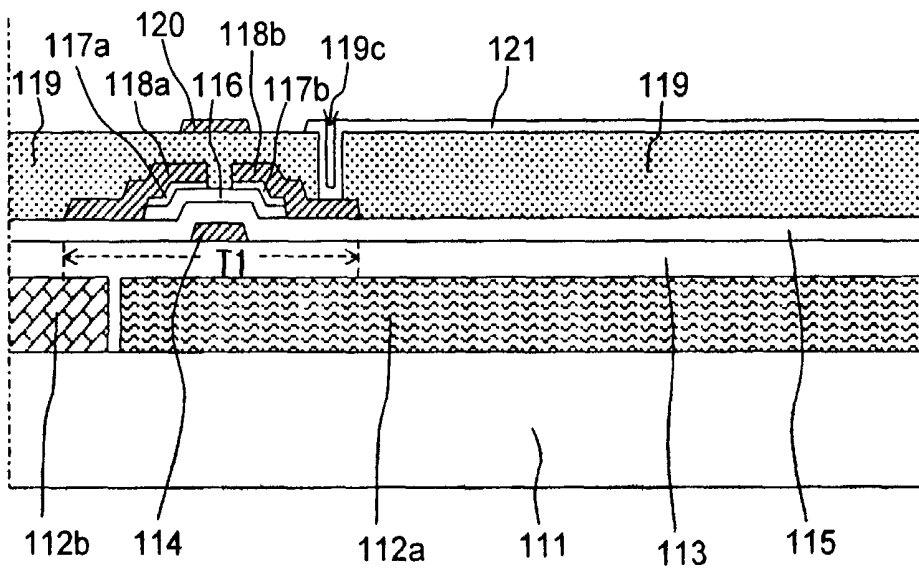

FIG. 3G

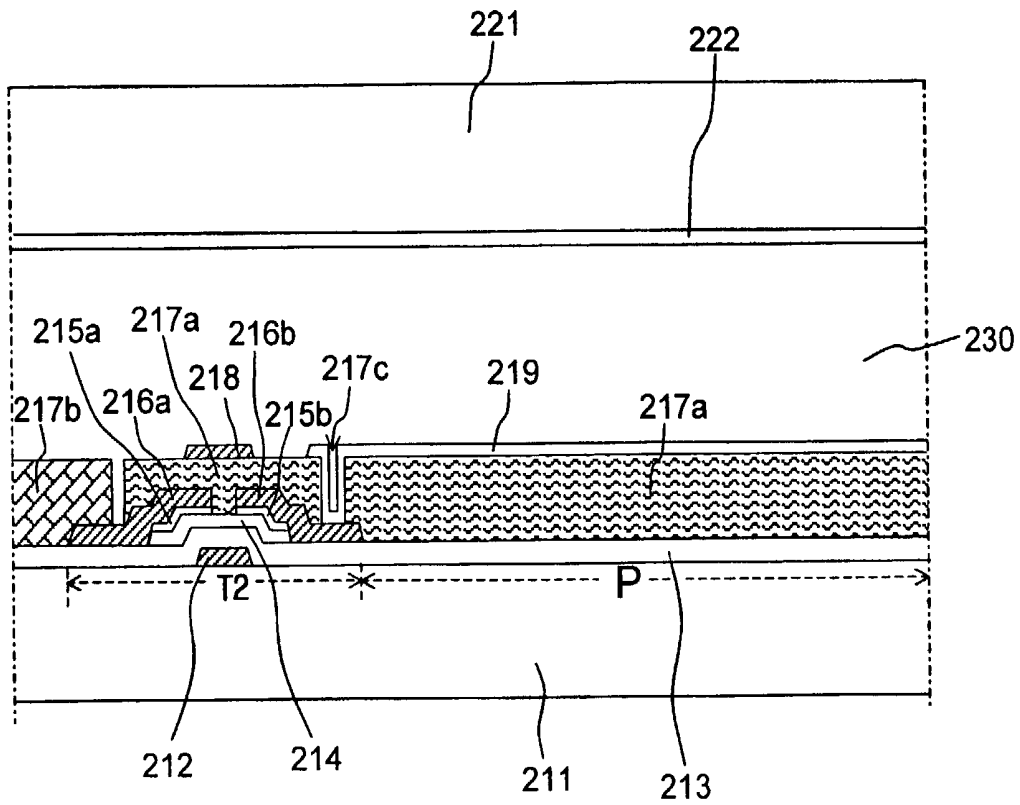

FIG. 4

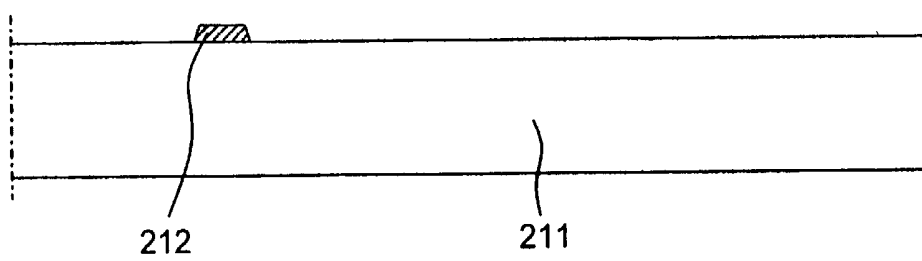

FIG. 5A

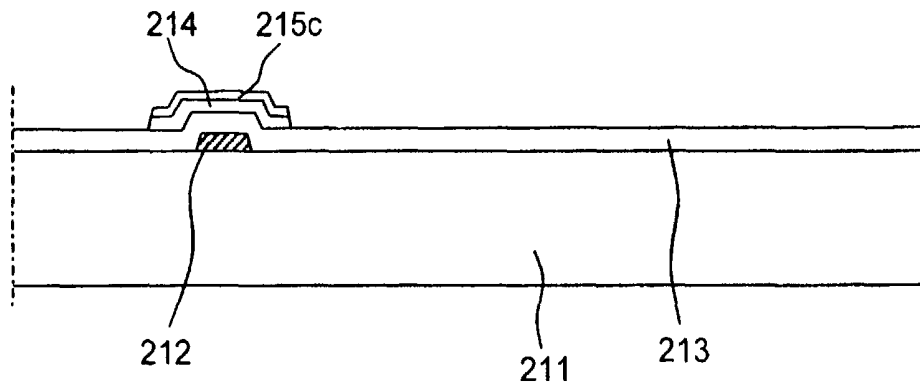

FIG. 5B

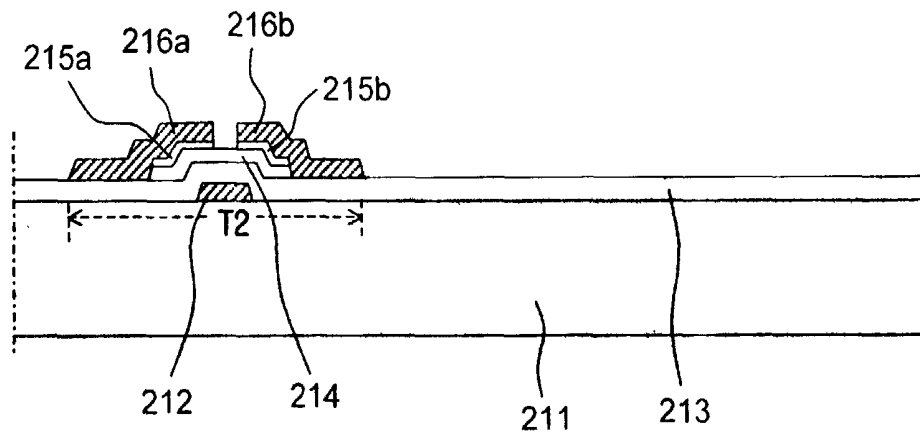

FIG. 5C

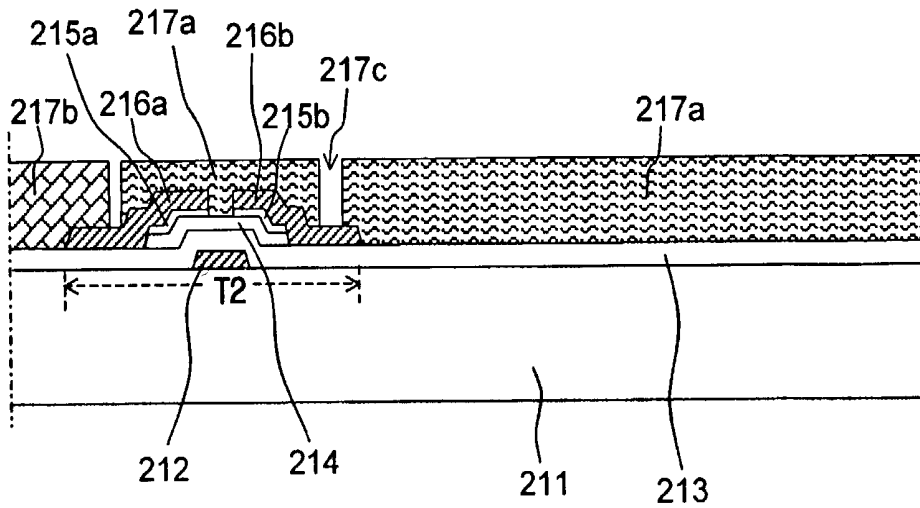

FIG. 5D

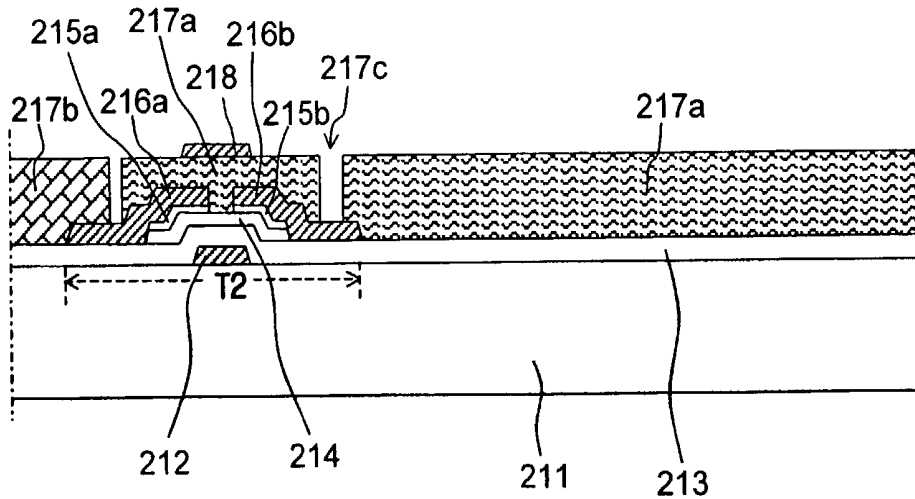

FIG. 5E

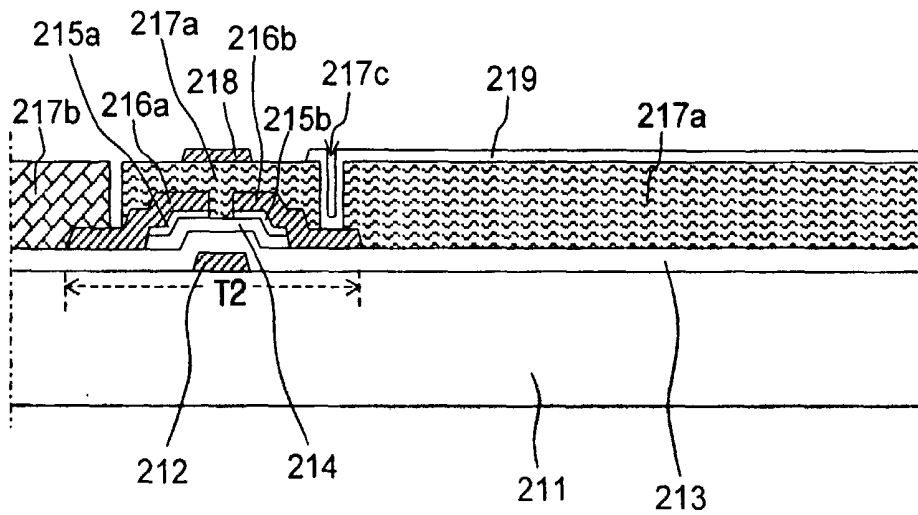

FIG. 5F

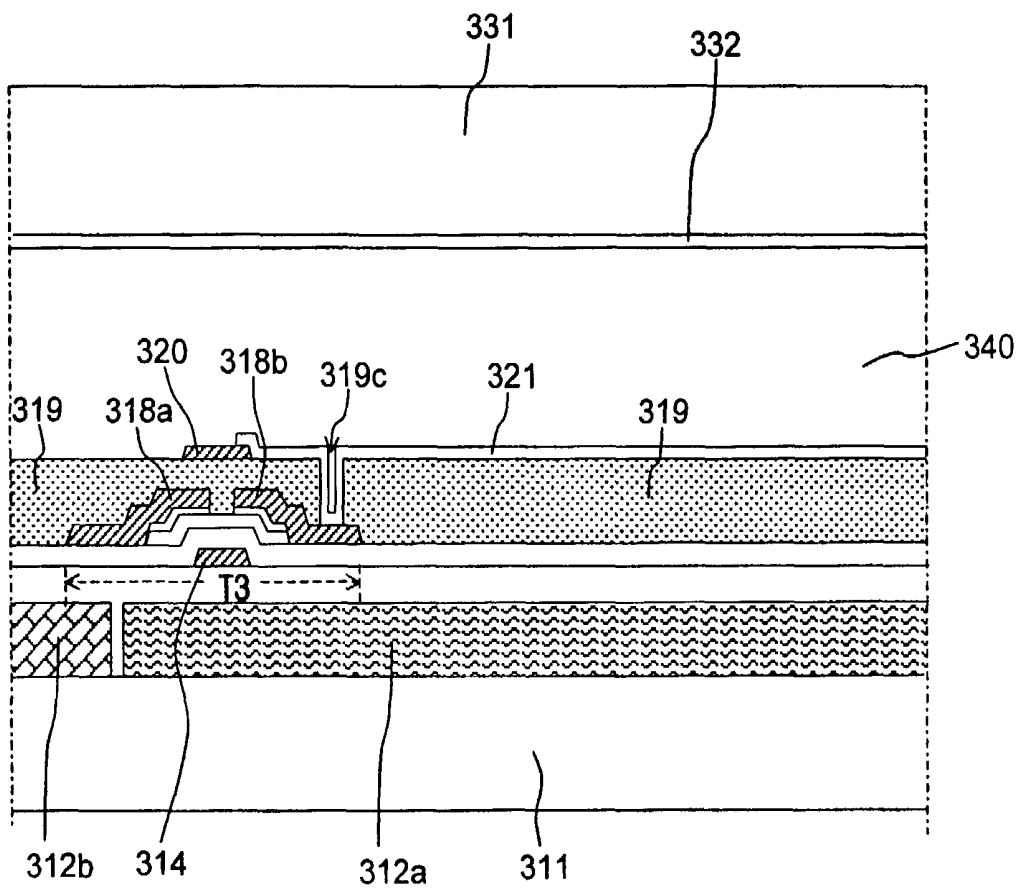

FIG. 6

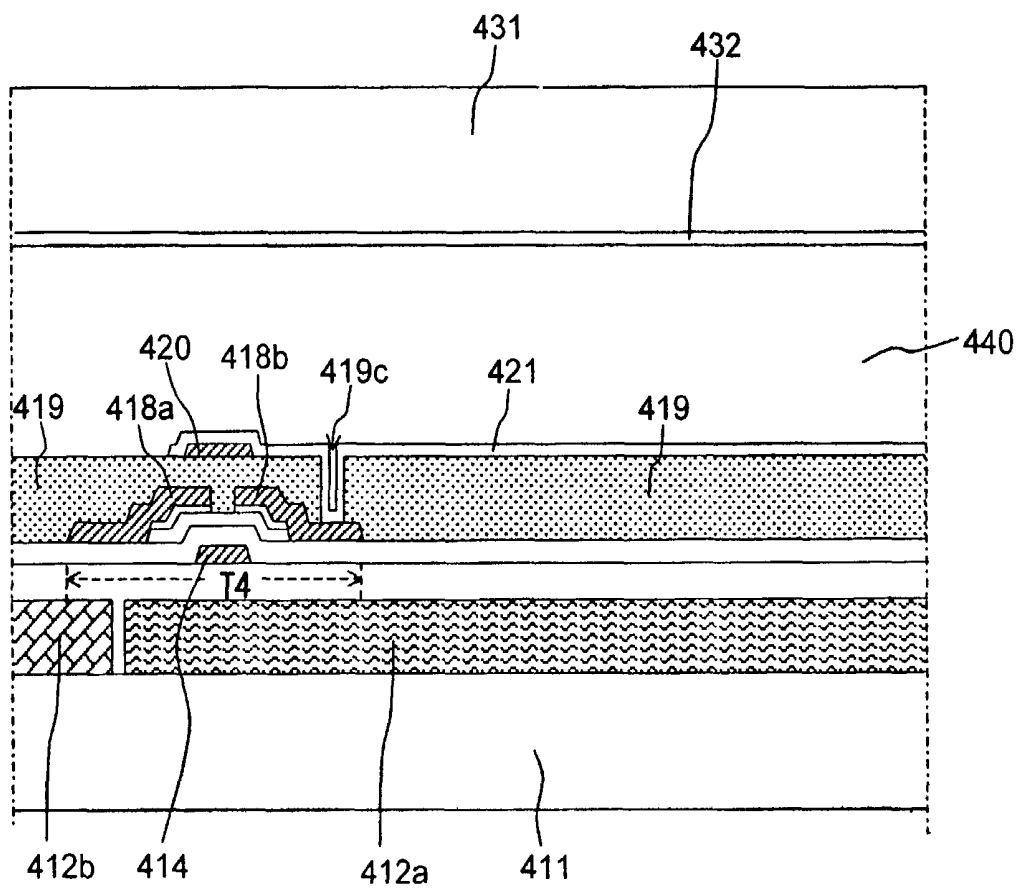

FIG. 7

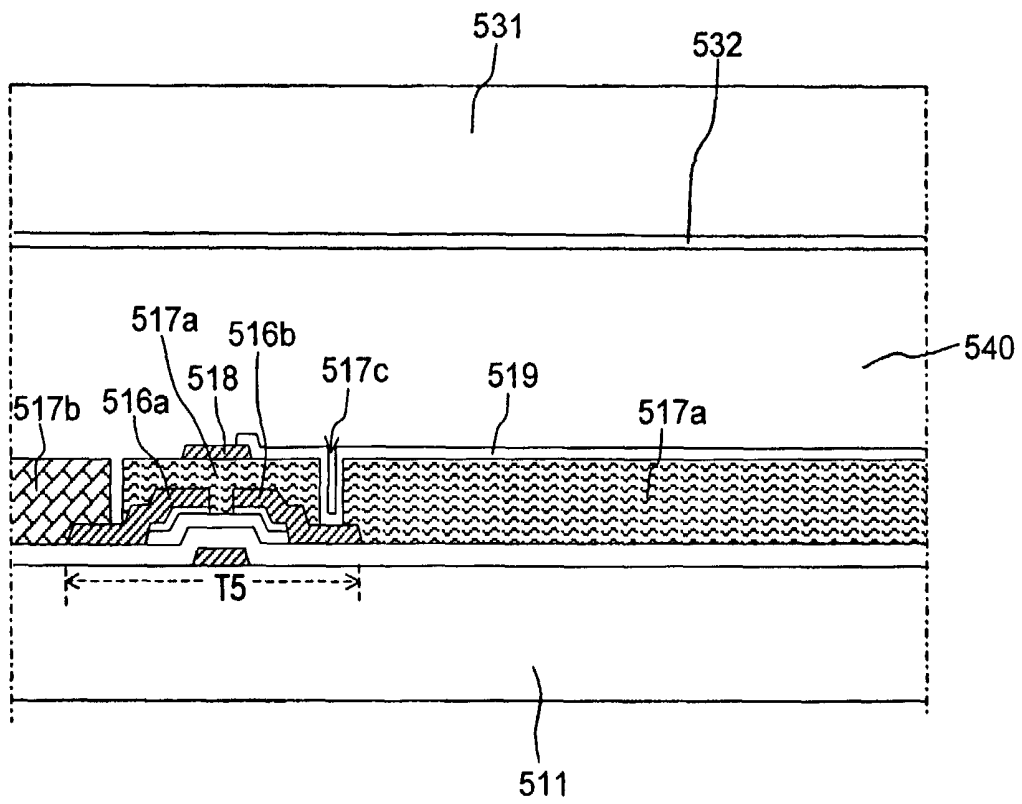

FIG. 8

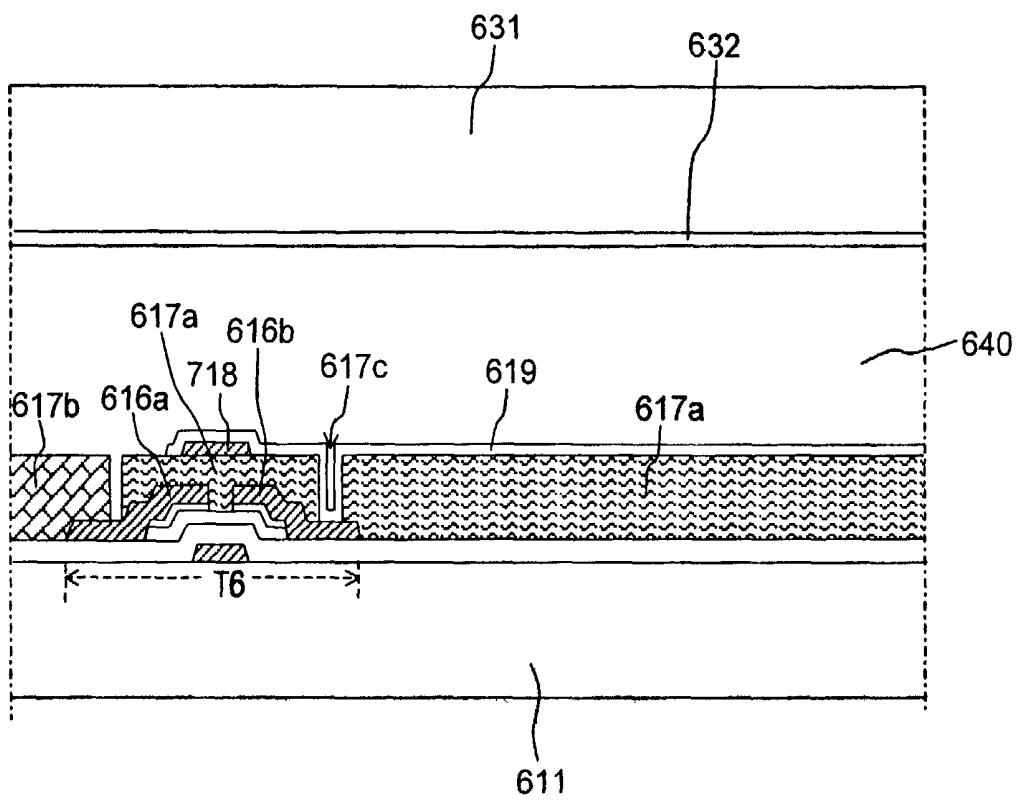

FIG. 9

LIQUID CRYSTAL DISPLAY DEVICE AND FABRICATING METHOD THEREOF

This application claims the benefit of the Korean Patent Application No. P2001-44757 filed on Jul. 25, 2001, which is hereby incorporated by reference.

BACKGROUND OF THE INVENTION

1. Field of the Invention

The present invention relates to a liquid crystal display, and more particularly, to a liquid crystal display device and a fabricating method thereof. Although the present invention is suitable for a wide scope of applications, it is particularly suitable for preventing a photocurrent generation and improving an aperture ratio of the liquid crystal display device.

2. Discussion of the Related Art

Flat panel display (FPD) devices having small size, lightweight, and low power consumption may have been a subject of recent research in the advent of the information age. Among many kinds of FPD devices, liquid crystal display (LCD) devices have been widely developed and used because of their excellent characteristics in resolution, color display, and display quality.

Generally, LCD devices include an upper substrate and a lower substrate facing into each other with liquid crystal molecules interposed therebetween. Each substrate has an electrode on the inner surface thereof. An electric field is generated by applying a voltage to the electrodes, thereby driving the liquid crystal molecules to display images in accordance with light transmittance.

The lower substrate is referred to as an array substrate including a thin film transistor (TFT) that is formed through repeated deposition of thin films, photolithography, and an etch process. The upper substrate is referred to as a color filter substrate including a color filter layer that is formed through a dyeing method, a printing method, a pigment dispersion method, or an electro-deposition method. Three colors of red (R), green (G), and blue (B) are alternately disposed in the color filter layer.

FIG. 1 is a cross-sectional view of a conventional LCD device.

In FIG. 1, a gate electrode **12** of a conductive material such as metal is formed on a first substrate **11**. A gate insulating layer **13** of silicon nitride (SiN_x) or silicon oxide (SiO₂) is formed on the gate electrode **12**. An active layer **14** of amorphous silicon is formed on the gate insulating layer **13** over the gate electrode **12**. An ohmic contact layer **15a** and **15b** of doped amorphous silicon is formed on the active layer **14**. Source and drain electrodes **16a** and **16b** of a conductive material such as metal are formed on the ohmic contact layer **15a** and **15b**. The source and drain electrodes **16a** and **16b** form a TFT "T" with the gate electrode **12**. The gate electrode **12** and the source electrode **16a** are connected to a gate line and a data line (not shown), respectively. The gate line and the data line cross each other and define a pixel region. A passivation layer **17** of SiN_x, SiO₂ or an organic insulating material is formed on the source and drain electrodes **16a** and **16b**. The passivation layer **17** includes a contact hole **17c** exposing the drain electrode **16b**. A pixel electrode **18** of a transparent conductive material is formed on the passivation layer **17** and connected to the drain electrode **16b** through the contact hole **17c**.

A second substrate **21** is disposed over and spaced apart from the first substrate **11**. A black matrix **22** corresponding to the TFT "T" is formed beneath the second substrate **21**. The black matrix **22** has an open portion (not shown) correspond-

ing to the pixel electrode **18**. The black matrix **22** prevents a light leakage at an LCD panel except for the pixel electrode **18** and a photocurrent generated by screening a channel of the TFT "T" from the ambient light. The black matrix **22** is formed in a color filter layer **23a** and **23b**. The color filter layer **23a** and **23b** having three colors of R, G, and B is alternately disposed. The color filter layer corresponds to the pixel region. A common electrode **24** of a transparent conductive material is formed beneath the color filter layer **23a** and **23b**. A liquid crystal layer **30** is interposed between the pixel electrode **18** and the common electrode **24**.

In a fabricating process of the conventional LCD device, the array substrate and the color filter substrate are respectively formed and attached in such a way that the pixel electrode of the array substrate corresponds to the color filter layer of the color filter substrate. When attaching the array substrate and the color filter substrate, deterioration such as light leakage may occur due to misalignment. To prevent this deterioration, the black matrix of the color filter substrate may be widened. However, as the black matrix becomes wider, an aperture ratio of the LCD device becomes lower.

Therefore, LCD devices having a new structure in which the color filter layer is disposed on the array substrate are suggested. In the LCD devices of the new structure, the width of the black matrix is reduced and the aperture ratio increases. The new structure may be classified into two types: TFT on color filter (TOC) type and color filter on TFT (COT) type. In the structure of the TOC type, a color filter layer is formed under a TFT. In the structure of COT type, a color filter layer is formed over a TFT. For both types, only a black matrix and a common electrode are formed on the color filter substrate.

However, since the black matrix is spaced apart from the TFT, the black matrix does not shield the oblique incident light or a portion of the light reflected at the black matrix. Therefore, such light reaches the channel of the TFT, thereby generating a photocurrent. Moreover, the TFT becomes non-uniform in characteristics.

SUMMARY OF THE INVENTION

Accordingly, the present invention is directed to a liquid crystal display device and a fabricating method thereof that substantially obviate one or more of problems due to limitations and disadvantages of the related art.

An object of the present invention is to provide a liquid crystal display device and a fabricating method thereof in which a photocurrent generation is effectively prevented and an aperture ratio is improved.

Another object of the present invention is to provide a liquid crystal display device and a fabricating method thereof in which an operating characteristic of a thin film transistor is improved.

Additional features and advantages of the invention will be set forth in the description which follows and in part will be apparent from the description, or may be learned by practice of the invention. The objectives and other advantages of the invention will be realized and attained by the structure particularly pointed out in the written description and claims hereof as well as the appended drawings.

To achieve these and other advantages and in accordance with the purpose of the present invention, as embodied and broadly described, a liquid crystal display device includes first and second substrates facing into each other, a gate line and a data line on an inner surface of the first substrate, the gate line and the data line defining a pixel region, a thin film transistor connected to the gate line and the data line, a pixel electrode connected to the thin film transistor and disposed at

the pixel region, a color filter layer disposed closer than the pixel electrode from the first substrate, the color filter layer corresponding to the pixel electrode, a black matrix over the thin film transistor, a common electrode on an inner surface of the second substrate, and a liquid crystal layer interposed between the pixel electrode and the common electrode.

In another aspect of the present invention, a fabricating method of an array substrate for a liquid crystal display device includes forming a color filter layer on a substrate, forming a gate line and a data line on the color filter layer, forming a thin film transistor connected to the gate line and the data line, forming a passivation layer over the thin film transistor, the gate line, and the data line, forming a black matrix on the passivation layer over the thin film transistor, and forming a pixel electrode on the passivation layer, the pixel electrode being connected to the thin film transistor.

In another aspect of the present invention, a fabricating method of an array substrate for a liquid crystal display device includes forming a gate line and a data line on a substrate, the gate line and the data line crossing each other, forming a thin film transistor connected to the gate line and the data line, forming a color filter layer over the thin film transistor, the gate line, and the data line, forming a black matrix on the color filter layer over the thin film transistor, and forming a pixel electrode on the color filter layer, the pixel electrode being connected to the thin film transistor.

It is to be understood that both the foregoing general description and the following detailed description are exemplary and explanatory and are intended to provide further explanation of the invention as claimed.

BRIEF DESCRIPTION OF THE DRAWINGS

The accompanying drawings, which are included to provide a further understanding of the invention and are incorporated in and constitute a part of this application, illustrate embodiments of the invention and together with the description serve to explain the principle of the invention.

In the drawings:

FIG. 1 is a cross-sectional view of a conventional LCD device;

FIG. 2 is a schematic cross-sectional view of a liquid crystal display device according to a first embodiment of the present invention;

FIGS. 3A to 3G are cross-sectional views showing a fabricating process of an array substrate for a liquid crystal display device according to the first embodiment of the present invention;

FIG. 4 is a schematic cross-sectional view of a liquid crystal display device according to a second embodiment of the present invention;

FIGS. 5A to 5F are cross-sectional views showing a fabricating process of an array substrate for a liquid crystal display device according to the second embodiment of the present invention;

FIG. 6 is a schematic cross-sectional view of a liquid crystal display device according to a third embodiment of the present invention;

FIG. 7 is a schematic cross-sectional view of a liquid crystal display device according to a fourth embodiment of the present invention;

FIG. 8 is a schematic cross-sectional view of a liquid crystal display device according to a fifth embodiment of the present invention; and

FIG. 9 is a schematic cross-sectional view of a liquid crystal display device according to a sixth embodiment of the present invention.

DETAILED DESCRIPTION OF THE ILLUSTRATED EMBODIMENTS

Reference will now be made in detail to the illustrated embodiments of the present invention, examples of which are illustrated in the accompanying drawings. Wherever possible, the same reference numbers will be used throughout the drawings to refer to the same or like parts.

FIG. 2 is a schematic cross-sectional view of a liquid crystal display device according to a first embodiment of the present invention. The LCD device of FIG. 2 has a TOC type structure in which a color filter layer is formed under a TFT.

In FIG. 2, a first substrate **111** and a second substrate **131** are facing into and spaced apart from each other. A color filter layer **112a** and **112b** is formed on the inner surface of the first substrate **111**. The color filter layer **112a** and **112b** having three colors of R, G, and B is alternately disposed. An overcoat layer **113** is formed on the color filter layer **112a** and **112b**. The overcoat layer **113** protects the color filter layer **112a** and **112b** and planarizes the top surface of the color filter layer **112a** and **112b** to stabilize the following processes.

A gate electrode **114** of a conductive material such as metal is formed on the overcoat layer **113** and a gate insulating layer **115** covers the gate electrode **114**. The gate electrode **114** is connected to a gate line (not shown). An active layer **116** of amorphous silicon is formed on the gate insulating layer **115** over the gate electrode **114**. An ohmic contact layer **117a** and **117b** of impurity-doped amorphous silicon is formed on the active layer **116**. Source and drain electrodes **118a** and **118b** facing into each other are formed on the ohmic contact layer **117a** and **117b**. The source and drain electrodes **118a** and **118b** form a TFT "T1" with the gate electrode **114**. The source electrode **118a** is connected to a data line (not shown) that crosses the gate line and defines a pixel region "P" with the gate line.

A passivation layer **119** is formed on the source and drain electrodes **118a** and **118b**. The passivation layer **119** has a contact hole **119c** exposing a portion of the drain electrode **118b**. A black matrix **120** of an opaque conductive material is formed on the passivation layer **119** over the TFT "T1". Further, a pixel electrode **121** of a transparent conductive material is formed on the passivation layer **119** at the pixel region and connected to the drain electrode **118b** through the contact hole **119c**.

A common electrode **132** of a transparent conductive material such as indium-tin-oxide (ITO) is formed on the inner surface of the second substrate **131**.

A liquid crystal layer **140** is interposed between the pixel electrode **121** and the common electrode **132**. An alignment layer (not shown) formed on each of the pixel electrode **121** and the common electrode **132** determines an initial alignment of the liquid crystal molecules.

FIGS. 3A to 3G are cross-sectional views showing a fabricating process of an array substrate for a liquid crystal display device according to the first embodiment of the present invention.

In FIG. 3A, a color filter layer **112a** and **112b** is formed on a substrate **111**. The color filter layer **112a** and **112b** may be fabricated through a dyeing method, a printing method, a pigment dispersion method, or an electro-deposition method. The pigment dispersion method is widely used due to its high elaborateness and good repeatability.

In FIG. 3B, an overcoat layer **113** is formed on the color filter layer **112a** and **112b** to eliminate the step generated by the color filter layer **112a** and **112b**. A gate electrode **114** of a conductive material such as metal is formed on the overcoat layer **113**. Simultaneously, a gate line (not shown) connected to the gate electrode **114** and extended along a first direction is also formed on the overcoat layer **113**.

In FIG. 3C, after forming a gate insulating layer **115** on the overcoat layer **113** including the gate electrode **114**, an active layer **116** and an impurity-doped semiconductor layer **117c** are formed on the gate insulating layer **115** by sequentially depositing and patterning amorphous silicon and impurity-doped amorphous silicon.

In FIG. 3D, source and drain electrodes **118a** and **118b** are formed on the impurity-doped semiconductor layer **117c** (shown in FIG. 3C) through depositing and patterning a metallic material. Next, an ohmic contact layer **117a** and **117b** is completed through etching the impurity-doped amorphous silicon between the source and drain electrodes **118a** and **118b**. A data line (not shown) connected to the source electrode **118a** and extended along a second direction is also formed. The data line crosses the gate line and defines a pixel region with the gate line. Here, the source and drain electrodes **118a** and **118b** form a TFT "T1" with the gate electrode **114**.

In FIG. 3E, a passivation layer **119** is formed on the source and drain electrodes **118a** and **118b** through depositing and patterning one of benzoocyclobutene (BCB) and an acrylic organic material having a low permittivity. The passivation layer **119** has a contact hole **119c** exposing the drain electrode **118b**.

In FIG. 3F, a black matrix **120** is formed on the passivation layer **119** over the TFT "T1" through depositing and patterning a metallic material. The black matrix **120** may be formed of one of chromium (Cr), molybdenum (Mo), and titanium (Ti). Alternatively, the black matrix may have an organic material. However, a cost of the organic material is higher than that of the metallic material and a patterning characteristic of the organic material is worse than that of the metallic material. Moreover, since the black matrix of the organic material generates a big step, rubbing for an alignment layer becomes imperfect. This causes a disclination.

In FIG. 3G, a pixel electrode **121** is formed on the passivation layer **119** at the pixel region through depositing and patterning one of ITO, indium-zinc-oxide (IZO) and indium-tin-zinc-oxide (ITZO). The pixel electrode **121** corresponds to the color filter layer **112a** and **112b** and contacts the drain electrode **118b** through the contact hole **119c**.

After the fabricating process of an array substrate, the array substrate is attached to a color filter substrate having a common electrode thereon and a liquid crystal layer is injected to complete an LCD device of FIG. 2. In the first embodiment of the present invention, a black matrix of a metallic material is formed over a TFT of an array substrate so that a photocurrent of the TFT is prevented.

FIG. 4 is a schematic cross-sectional view of a liquid crystal display device according to a second embodiment of the present invention. The LCD device of FIG. 2 has a COT type structure in which a color filter layer is formed over a TFT.

In FIG. 4, a first substrate **211** and a second substrate **221** are facing into and spaced apart from each other. A gate electrode **212** of a conductive material such as metal is formed on the inner surface of the first substrate **211** and a gate insulating layer **213** covers the gate electrode **212**. The gate electrode **212** is connected to a gate line (not shown). An active layer **214** of amorphous silicon is formed on the gate insulating layer **213** over the gate electrode **212**. An ohmic

contact layer **215a** and **215b** of impurity-doped amorphous silicon is formed on the active layer **214**. Source and drain electrodes **216a** and **216b** forming a TFT "T2" with the gate electrode **212** are formed on the ohmic contact layer **215a** and **215b**. The source electrode **216a** is connected to a data line (not shown) that crosses the gate line and defines a pixel region "P" with the gate line.

A color filter layer **217a** and **217b** is formed on the source and drain electrodes **216a** and **216b**. The color filter layer **217a** and **217b** having three colors of R, G, and B is alternately disposed and the color filter layer of one color corresponds to one pixel region. The color filter layer **217a** on the drain electrode **216b** has a contact hole **217c** exposing the drain electrode **216b**. As a development of the material for the color filter layer **217a** and **217b**, the color filter layer **217a** and **217b** does not damage underlying layers. Accordingly, a protecting layer under the color filter layer **217a** and **217b** is not necessary. A black matrix **218** of an opaque conductive material is formed on the color filter layer **217a** over the TFT "T2". Further, a pixel electrode **219** of a transparent conductive material is formed on the color filter layer **217a** at the pixel region and connected to the drain electrode **216b** through the contact hole **217c**.

A common electrode **222** of a transparent conductive material such as indium-tin-oxide (ITO) is formed on the inner surface of the second substrate **221**.

A liquid crystal layer **230** is interposed between the pixel electrode **219** and the common electrode **222**.

FIGS. 5A to 5G are cross-sectional views showing a fabricating process of an array substrate for a liquid crystal display device according to the second embodiment of the present invention.

In FIG. 5A, a gate electrode **212** of a conductive material such as metal is formed on a substrate **211**. Simultaneously, a gate line (not shown) connected to the gate electrode **212** and extended along a first direction is also formed on the substrate **211**.

In FIG. 5B, a gate insulating layer **213** is formed on the gate electrode **212** including the substrate **211**. After sequentially depositing amorphous silicon and impurity-doped amorphous silicon, an active layer **214** and an impurity-doped semiconductor layer **215c** are formed on the gate insulating layer **213** through patterning.

In FIG. 5C, source and drain electrodes **216a** and **216b** are formed on the impurity-doped semiconductor layer **215c** (shown in FIG. 5B) through depositing and patterning a metallic material. Next, an ohmic contact layer **215a** and **215b** is completed through etching the impurity-doped amorphous silicon between the source and drain electrodes **216a** and **216b**. A data line (not shown) connected to the source electrode **216a** and extended along a second direction is also formed. The data line crosses the gate line and defines a pixel region with the gate line. Here, the source and drain electrodes **216a** and **216b** compose a TFT "T2" with the gate electrode **212**.

In FIG. 5D, a color filter layer **217a** and **217b** is formed on the source and drain electrodes **216a** and **216b**. The color filter layer **217a** and **217b** has a contact hole **217c** exposing the drain electrode **216b**. The color filter layer **217a** and **217b** may be fabricated through a dyeing method, a printing method, a pigment dispersion method, or an electro-deposition method.

In FIG. 5E, a black matrix **218** is formed on the color filter layer **217a** and **217b** over the TFT "T2" through depositing and patterning a metallic material. The black matrix **218** may be formed of one of chromium (Cr), molybdenum (Mo), and titanium (Ti).

In FIG. 5F, a pixel electrode **219** is formed on the color filter layer **217a** and **217b** at the pixel region through depositing and patterning one of ITO, IZO, and ITZO. The pixel electrode **219** is connected to the drain electrode **216b** through the contact hole **217c**.

In the second embodiment of the present invention, a black matrix of the metallic material is formed over a TFT of an array substrate so that a photocurrent of the TFT is not generated.

Moreover, a voltage may be applied to the black matrix through connecting the black matrix and the pixel electrode, thereby improving characteristics of the TFT.

FIG. 6 is a schematic cross-sectional view of a liquid crystal display device according to a third embodiment of the present invention. Since the third embodiment is similar to the first embodiment, illustrations for the same part will be omitted.

In FIG. 6, first and second substrates **311** and **331** face into each other. A color filter layer **312a** and **312b** is formed on the inner surface of the first substrate **311** and a TFT "T3" including a gate electrode **314**, source and drain electrodes **318a** and **318b** is formed over the color filter layer **312a** and **312b**. A passivation layer **319** having a contact hole **319c** covers the TFT "T3". The contact hole **319c** exposes the drain electrode **318b**. A black matrix **320** of a metallic material such as Cr, Mo, and Ti is formed on the passivation layer **319** over the TFT "T3". A pixel electrode **321** is formed on the passivation layer **319** at a pixel region. The pixel electrode **321** is connected to the black matrix **320** and to the drain electrode **318b** through the contact hole **319c**. A common electrode **332** is formed on the inner surface of the second substrate **331**. A liquid crystal layer **340** is interposed between the pixel electrode **321** and the common electrode **332**.

FIG. 7 is a schematic cross-sectional view of a liquid crystal display device according to a fourth embodiment of the present invention. Since the fourth embodiment is similar to the first embodiment, illustrations for the same part will be omitted.

In FIG. 7, first and second substrates **411** and **431** face into each other. A color filter layer **412a** and **412b** is formed on the inner surface of the first substrate **411** and a TFT "T4" including a gate electrode **414**, source and drain electrodes **418a** and **418b** is formed over the color filter layer **412a** and **412b**. A passivation layer **419** having a contact hole **419c** covers the TFT "T4". The contact hole **419c** exposes the drain electrode **418b**. A black matrix **420** of a metallic material such as Cr, Mo, and Ti is formed on the passivation layer **419** over the TFT "T4". A pixel electrode **421** is formed on the passivation layer **419** at a pixel region. The pixel electrode **421** is connected to the drain electrode **418b** through the contact hole **419c** and contacts the black matrix **420**. A common electrode **432** is formed on the inner surface of the second substrate **431**. A liquid crystal layer **440** is interposed between the pixel electrode **421** and the common electrode **432**.

In the third and fourth embodiments of the present invention, a voltage of the pixel electrode is applied to the black matrix through connecting the black matrix and the pixel electrode. Accordingly, the black matrix controls charges in a back channel of the TFT so that an effect of the dual gate TFT can be obtained. Moreover, the pixel electrode of the fourth embodiment protects the black matrix.

FIG. 8 is a schematic cross-sectional view of a liquid crystal display device according to a fifth embodiment of the present invention. Since the fifth embodiment is similar to the second embodiment, illustrations for the same part will be omitted.

In FIG. 8, first and second substrates **511** and **531** face into each other. A TFT "T5" is formed on the inner surface of the first substrate **511** and a color filter layer **517a** and **517b** is formed on the TFT "T5". The color filter layer **517a** and **517b** has a contact hole **517c** exposing a drain electrode **516b** of the TFT "T5". A black matrix **518** of a metallic material such as Cr, Mo, and Ti is formed on the color filter layer **517a** and **517b** over the TFT "T5". A pixel electrode **519** is formed on the color filter layer **517a** and **517b** at a pixel region. The pixel electrode **519** is connected to the black matrix **518** and to the drain electrode **516b** through the contact hole **517c**. A common electrode **532** is formed on the inner surface of the second substrate **531**. A liquid crystal layer **540** is interposed between the pixel electrode **519** and the common electrode **532**.

FIG. 9 is a schematic cross-sectional view of a liquid crystal display device according to a sixth embodiment of the present invention. Since the sixth embodiment is similar to the second embodiment, illustrations for the same part will be omitted.

In FIG. 9, first and second substrates **611** and **631** face into each other. A TFT "T6" is formed on the inner surface of the first substrate **611** and a color filter layer **617a** and **617b** is formed on the TFT "T6". The color filter layer **617a** and **617b** has a contact hole **617c** exposing a drain electrode **616b** of the TFT "T6". A black matrix **618** of a metallic material such as Cr, Mo, and Ti is formed on the color filter layer **617a** and **617b** over the TFT "T6". A pixel electrode **619** is formed on the color filter layer **617a** and **617b** at a pixel region. The pixel electrode **619** is connected to the drain electrode **616b** through the contact hole **617c** and contacts the black matrix **618**. A common electrode **632** is formed on the inner surface of the second substrate **631**. A liquid crystal layer **640** is interposed between the pixel electrode **619** and the common electrode **632**.

In the fifth and sixth embodiments of the present invention, characteristics of the TFT are improved and the black matrix is protected.

Consequently, since a color filter layer is formed on an array substrate and a black matrix is formed over a TFT on an array substrate, an aperture ratio increases and a photocurrent of the TFT is prevented. Here, a patterning characteristic is improved and an imperfect rubbing problem is solved due to a black matrix of a conductive material. Moreover, a TFT characteristic is improved through connecting the black matrix and the pixel electrode.

It will be apparent to those skilled in the art that various modifications and variations can be made in the liquid crystal display device and the fabricating method thereof of the present invention without departing from the spirit or scope of the inventions. Thus, it is intended that the present invention covers the modifications and variations of this invention provided they come within the scope of the appended claims and their equivalents.

What is claimed is:

1. A liquid crystal display device, comprising:
 - first and second substrates facing into each other;
 - a gate line and a data line on an inner surface of the first substrate, the gate line and the data line defining a pixel region;
 - a thin film transistor connected to the gate line and the data line;
 - a passivation layer of an organic material directly on the film transistor, wherein the passivation layer has a contact hole exposing the thin film transistor;

9

- a pixel electrode connected to the thin film transistor through the contact hole and disposed at the pixel region, wherein the pixel electrode is formed directly on the passivation layer;
- a color filter layer disposed closer than the pixel electrode from the first substrate, the color filter layer corresponding to the pixel electrode and the pixel region, wherein two adjacent color filter layers in two adjacent pixel regions are spaced apart from each other to define a gap with the first substrate;
- an overcoat layer on the color filter layer that protects and planarizes the color filter layer, wherein the gap is filled with the overcoat layer such that a step generated by the gap is eliminated, and wherein a top surface of the overcoat layer is flat without a through hole;
- a black matrix over the thin film transistor, wherein the black matrix includes a conductive metallic material, wherein the black matrix is formed directly on the passivation layer;
- a common electrode on an inner surface of the second substrate; and
- a liquid crystal layer interposed between the pixel electrode and the common electrode, wherein the pixel electrode covers the entire black matrix to sandwich the black matrix between the pixel electrode and the thin film transistor and is electrically connected to the entire black matrix and wherein the color filter layer is formed under the thin film transistor.
2. The device according to claim 1, wherein the color filter layer has three colors of red, green, and blue.
3. The device according to claim 1, wherein the black matrix is formed of one of chromium, molybdenum, and titanium.

10

4. The device according to claim 1, wherein the pixel electrode directly contacts the black matrix.
5. The device according to claim 1, wherein the color filter layer overlaps with the thin film transistor.
6. The device according to claim 1, wherein the color filter layer is directly below the thin film transistor.
7. The device according to claim 1, wherein the black matrix is between the passivation layer and the second substrate.
8. A liquid crystal display device, comprising:
 first and second substrates facing each other;
 a color filter layer on the first substrate;
 an overcoat layer on the color filter layer;
 a thin film transistor on the overcoat layer;
 a passivation layer directly on the thin film transistor, the passivation layer having a contact hole exposing the thin film transistor;
 a black matrix directly on the passivation layer and over the thin film transistor;
 a pixel electrode directly on the passivation layer and connected to the thin film transistor through the contact hole;
 a common electrode on the second substrate; and
 a liquid crystal layer interposed between the pixel electrode and the common electrode, wherein the thin film transistor and is between the color filter layer and the black matrix.
9. The device according to claim 8, wherein the thin film transistor is over the color filter layer.
10. The device according to claim 8, wherein the black matrix is between the passivation layer and the second substrate.

* * * * *

专利名称(译)	液晶显示装置及其制造方法		
公开(公告)号	US9274390	公开(公告)日	2016-03-01
申请号	US10/201922	申请日	2002-07-25
[标]申请(专利权)人(译)	乐金显示有限公司		
申请(专利权)人(译)	LG.飞利浦液晶CO., LTD.		
当前申请(专利权)人(译)	LG DISPLAY CO., LTD.		
[标]发明人	CHANG YOUN GYOUNG KIM WOONG KWON		
发明人	CHANG, YOUN-GYOUNG KIM, WOONG-KWON		
IPC分类号	G02F1/1362 G02F1/1335		
CPC分类号	G02F1/136209 G02F2001/136222 G02F2201/40		
代理机构(译)	DENTONS美国律师事务所		
优先权	1020010044757 2001-07-25 KR		
其他公开文献	US20030020852A1		
外部链接	Espacenet USPTO		

摘要(译)

液晶显示装置包括彼此面对的第一和第二基板，在第一基板的内表面上的栅极线和数据线，栅极线和数据线限定像素区域，薄膜晶体管连接到栅极线和数据线，连接到薄膜晶体管并设置在像素区域的像素电极，设置在比第一基板更靠近像素电极的滤色器层，滤色器层对应于像素电极，黑色薄膜晶体管上方的基质，第二基板内表面上的公共电极，以及插入像素电极和公共电极之间的液晶层。

