



US008098220B2

(12) **United States Patent**
Chiang et al.

(10) **Patent No.:** **US 8,098,220 B2**
(45) **Date of Patent:** **Jan. 17, 2012**

(54) **LIQUID CRYSTAL DISPLAY AND OPERATION METHOD THEREOF**

(75) Inventors: **Min-Feng Chiang**, Hsin-Chu (TW);
Hsueh-Ying Huang, Hsin-Chu (TW);
Ming-Sheng Lai, Hsin-Chu (TW)

(73) Assignee: **AU Optronics Corporation**, Hsin-Chu (TW)

(*) Notice: Subject to any disclaimer, the term of this patent is extended or adjusted under 35 U.S.C. 154(b) by 0 days.

6,414,665	B2 *	7/2002	Libsch et al.	345/92
6,486,930	B1 *	11/2002	Kwon	349/48
6,850,302	B2	2/2005	Song et al.	
7,071,911	B2	7/2006	Inukai	
7,173,676	B2 *	2/2007	Jeon et al.	349/48
7,355,666	B2	4/2008	Song et al.	
7,535,448	B2	5/2009	Hiroki	
7,633,472	B2 *	12/2009	Edwards	345/87
2003/0095223	A1	5/2003	Song et al.	
2004/0017341	A1 *	1/2004	Maki	345/87
2004/0155855	A1	8/2004	Chang	

(Continued)

FOREIGN PATENT DOCUMENTS

TW 200415560 8/2004
(Continued)

(21) Appl. No.: **12/912,132**

(22) Filed: **Oct. 26, 2010**

Prior Publication Data

US 2011/0037741 A1 Feb. 17, 2011

Related U.S. Application Data

(63) Continuation of application No. 11/745,629, filed on May 8, 2007, now Pat. No. 7,847,773.

Foreign Application Priority Data

Aug. 25, 2006 (TW) 95131461 A

(51) **Int. Cl.**
G09G 3/36 (2006.01)

(52) **U.S. Cl.** **345/93; 345/95**

(58) **Field of Classification Search** 345/87, 345/88, 90, 92, 93-100, 694, 695
See application file for complete search history.

References Cited

U.S. PATENT DOCUMENTS

5,448,258	A	9/1995	Edwards
5,648,793	A	7/1997	Chen
5,825,343	A	10/1998	Moon
5,903,249	A	5/1999	Koyama et al.

(57) **ABSTRACT**

A pixel unit in the present invention is divided into two sub-pixels. Each sub-pixel includes a thin film transistor, a liquid crystal capacitor and a storage capacitor. The two transistors respectively located in different sub-pixels are connected to different scan lines. One of the two transistors is connected to the data line through another transistor. Therefore, two different pixel voltages are formed in a pixel.

11 Claims, 6 Drawing Sheets

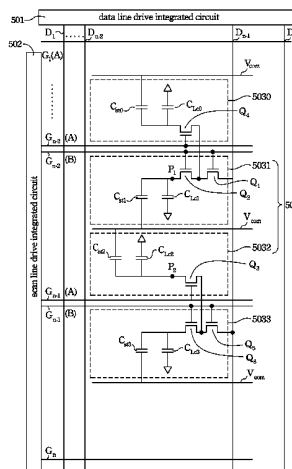

U.S. PATENT DOCUMENTS

2005/0122441 A1 6/2005 Shimoshikiryo
2006/0023137 A1 2/2006 Kamada et al.
2006/0164352 A1* 7/2006 Yoo et al. 345/87
2006/0284811 A1* 12/2006 Huang 345/92
2007/0097057 A1 5/2007 Shin

FOREIGN PATENT DOCUMENTS

TW 240103 B 9/2005
TW 200604986 2/2006
TW I322401 3/2010
TW I330746 9/2010

OTHER PUBLICATIONS

English language translation of abstract of TW 240103B (published Sep. 21, 2005).
English language translation of abstract of TW 200604986 (published Feb. 1, 2006).
English language translation of abstract of TW I322401 (published Mar. 21, 2010).
English language translation of abstract of TW I330746 (published Sep. 21, 2010).
S.S. Kim; "66.1: Invited Paper: the World's Largest (82-in.) TFT-LCD;" SID 05 Digest; 2005; pp. 1842-1847.

* cited by examiner

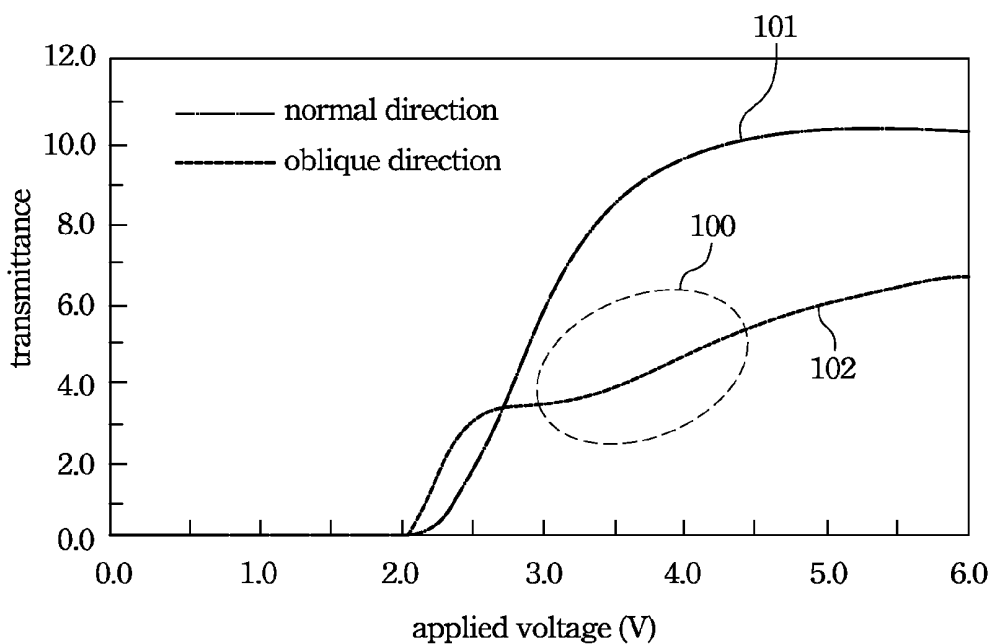

Fig. 1
(PRIOR ART)

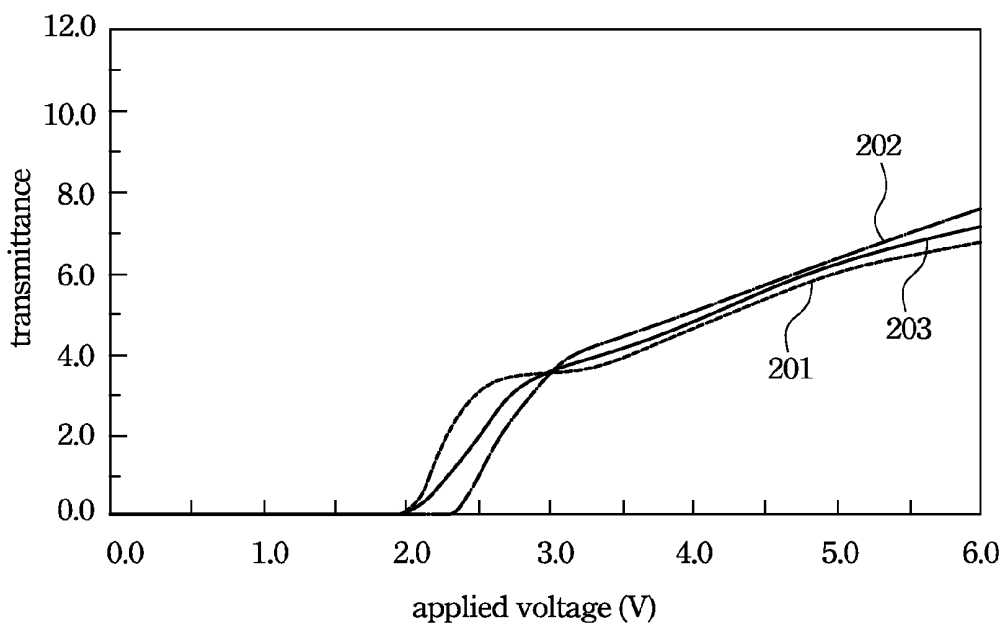

Fig. 2
(PRIOR ART)

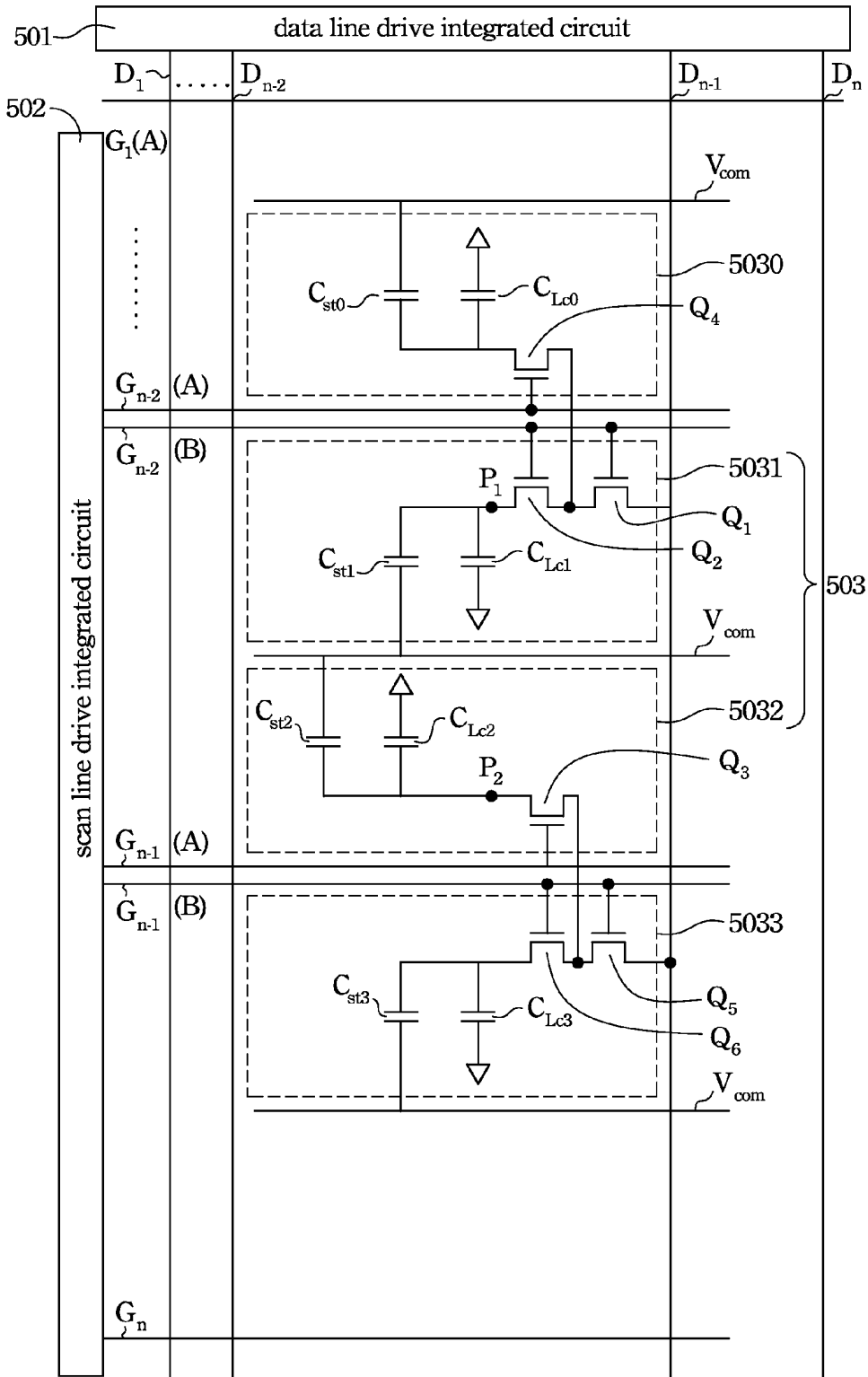

Fig. 3

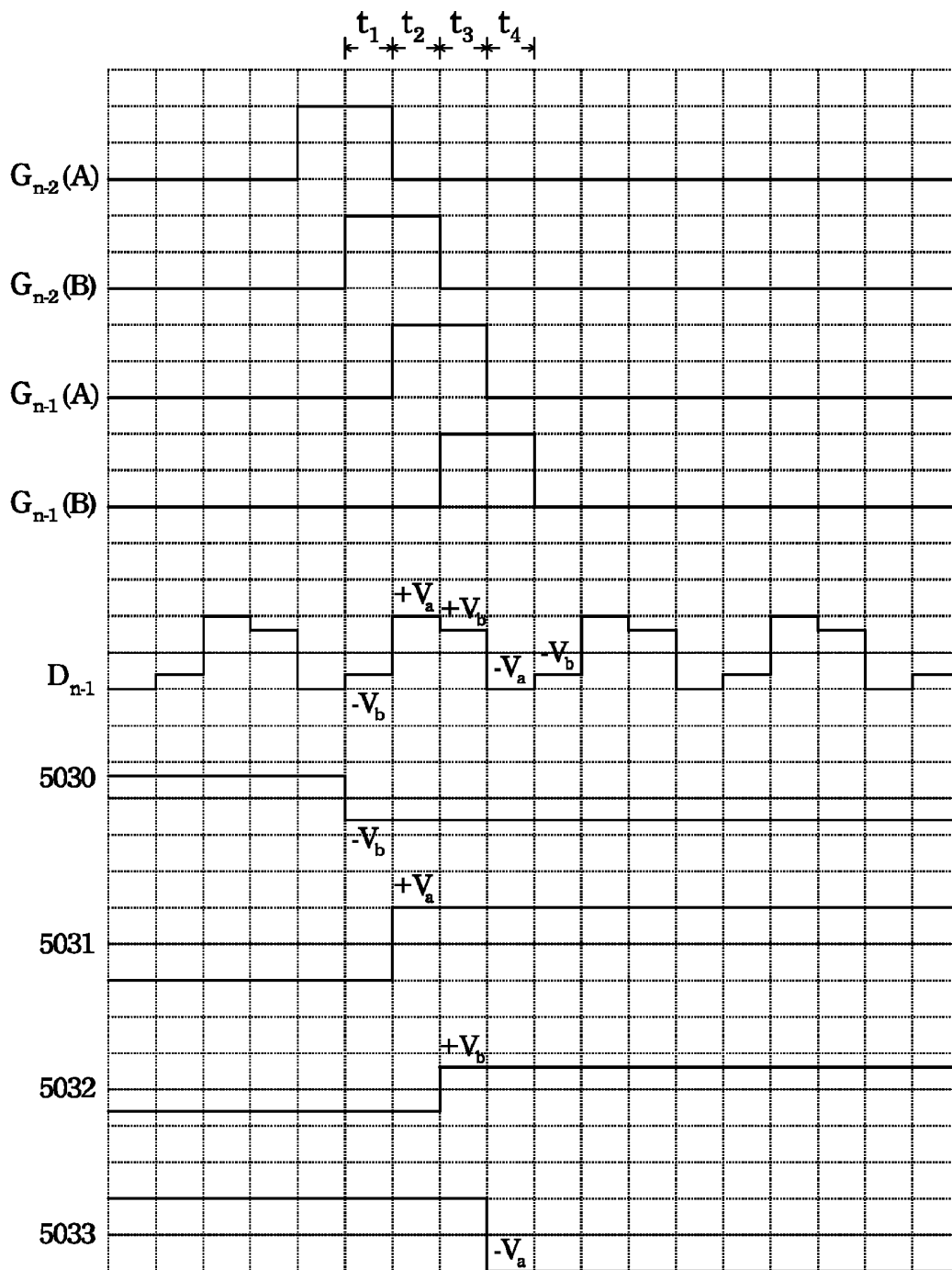

Fig. 4A

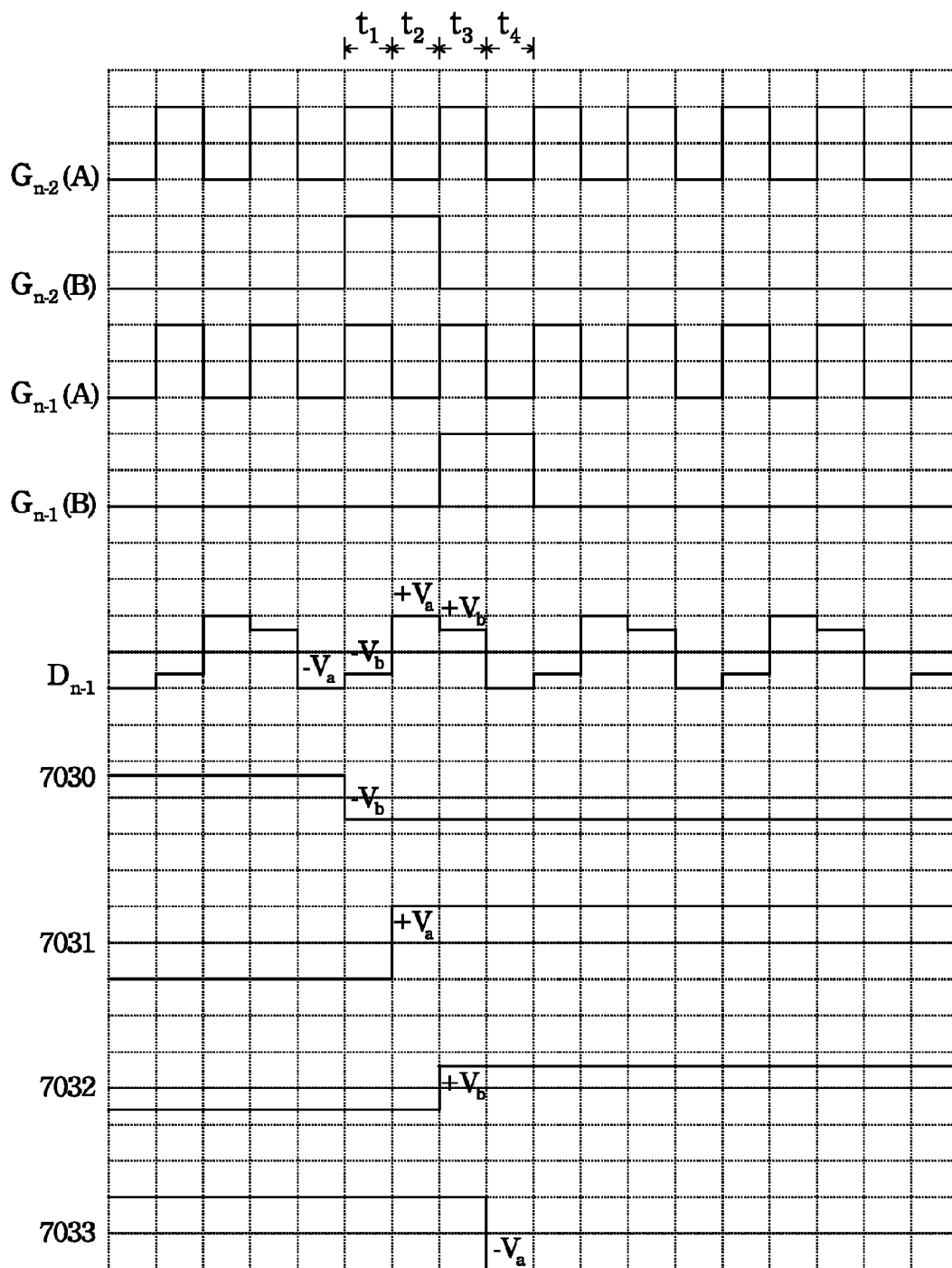

Fig. 4B

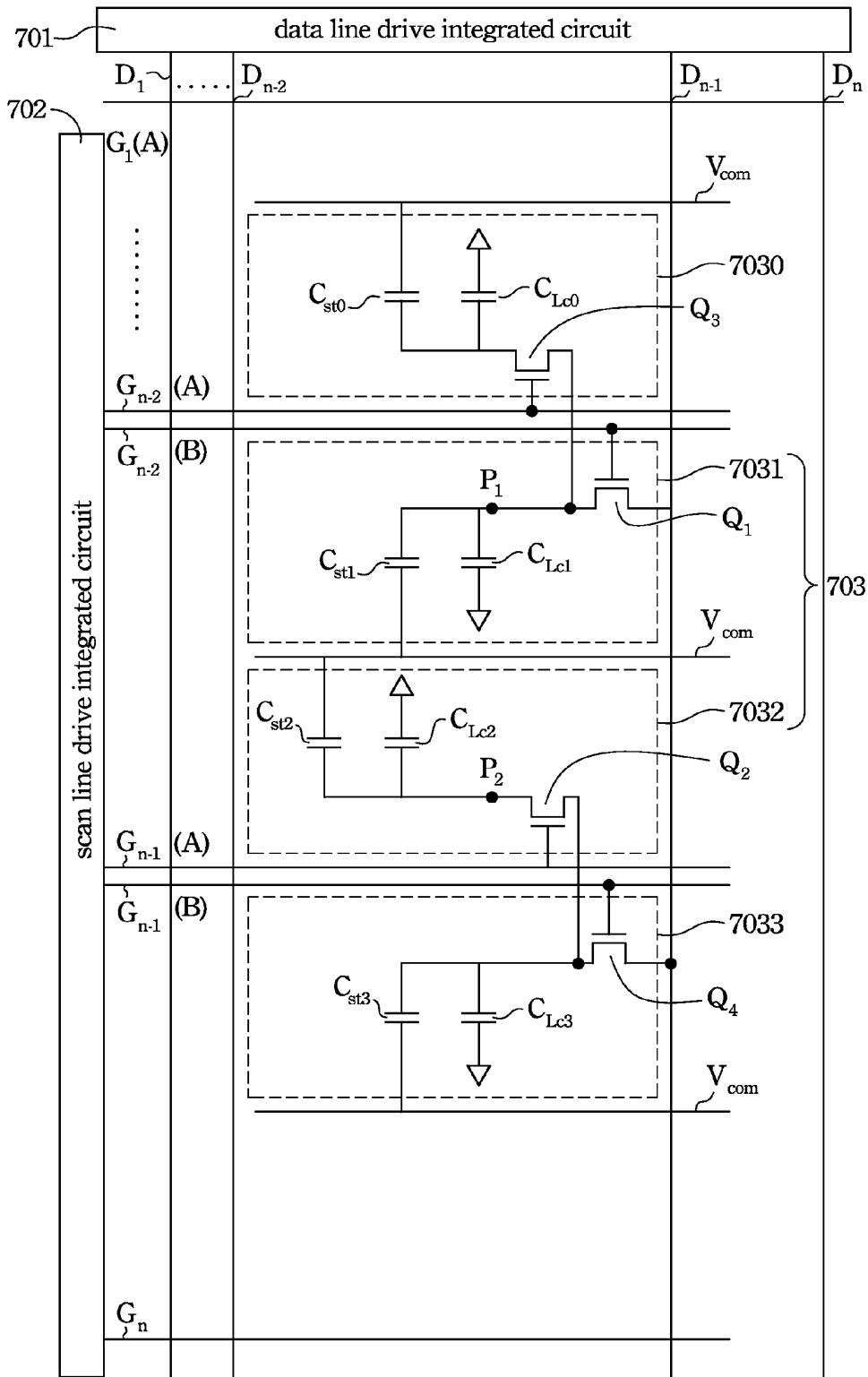

Fig. 5

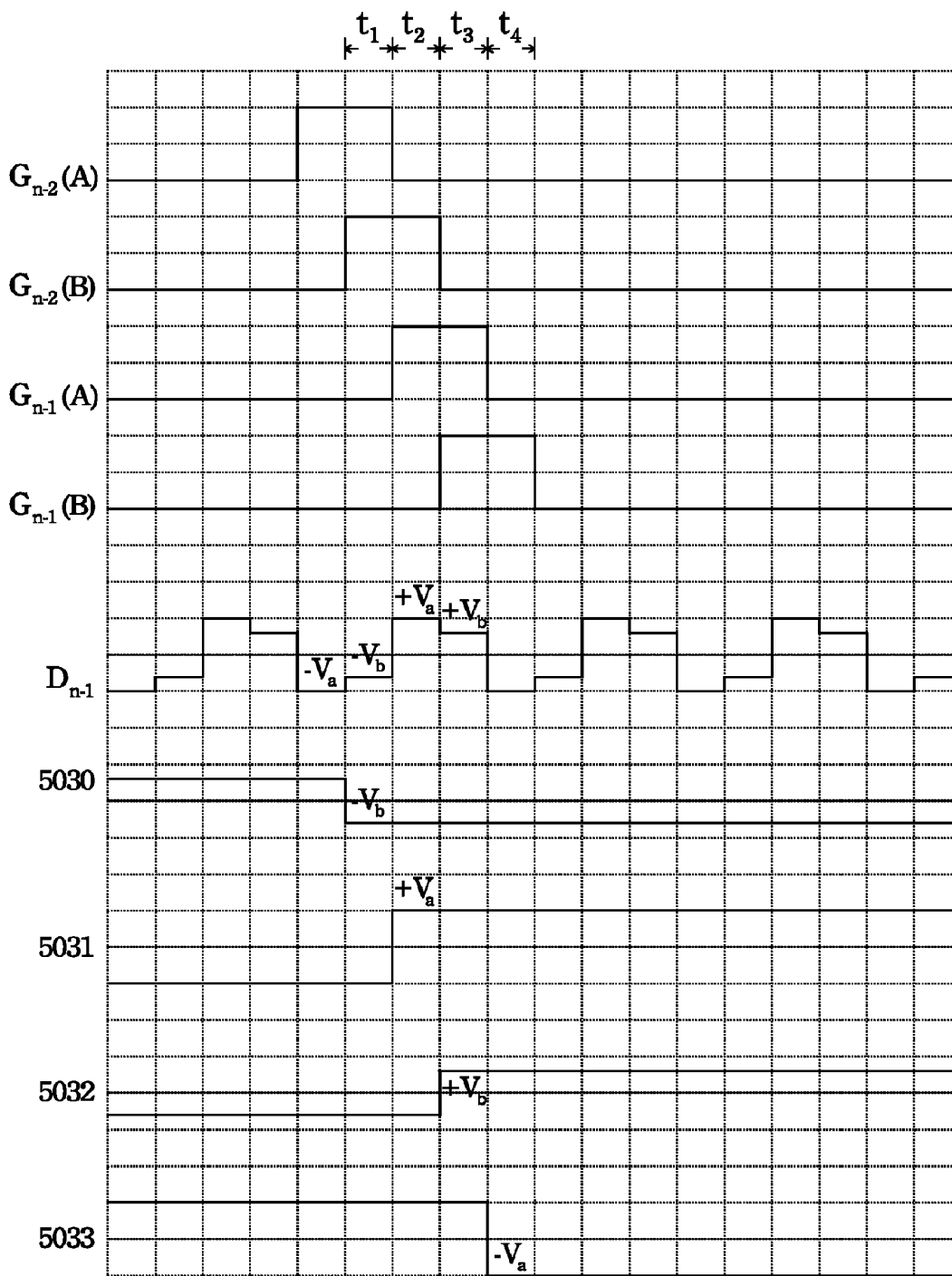

Fig. 6

LIQUID CRYSTAL DISPLAY AND OPERATION METHOD THEREOF

RELATED APPLICATIONS

This application is a continuation of U.S. patent application Ser. No. 11/745,629, filed May 8, 2007, now U.S. Pat. No. 7,847,773, which claims priority to Taiwan Patent Application Serial Number 95131461, filed Aug. 25, 2006, the disclosure of which is hereby incorporated by reference herein in its entirety.

FIELD OF THE INVENTION

The present invention relates to a liquid crystal display, and more particularly, to a liquid crystal display with improved view angles.

BACKGROUND OF THE INVENTION

Liquid crystal displays have been used in various electronic devices. A Multi-Domain Vertically Aligned Mode (MVA mode) liquid crystal display is developed by Fujitsu in 1997 to provide a wider viewing range. In the MVA mode, a 160 degree view angle and a high response speed may be realized. However, when a user looks at this LCD from the oblique direction, the skin color of Asian people (light orange or pink) appears bluish or whitish from an oblique viewing direction. Such a phenomenon is called color shift.

The transmittance-voltage (T-V) characteristic of the MVA mode liquid crystal display is shown in FIG. 1. The vertical axis is the transmittance rate. The horizontal axis is the applied voltage. When the applied voltage is increased, the transmittance rate curve **101** in the normal direction is also increased. The transmittance changes monotonically as the applied voltage increases. In the oblique direction, the transmittance rate curve **102** winds and the various gray scales become the same. However, in the region **100**, when the applied voltage is increased, the transmittance rate curve **102** is not increased. That is the reason to cause the color shift.

A method is provided to improve the foregoing problem. According to the method, a pixel unit is divided into two sub pixels. The two sub pixels may generate two different T-V characteristics. By combining the two different T-V characteristics, a monotonic T-V characteristic can be realized. The line **201** in FIG. 2 shows the T-V characteristic of a sub-pixel. The line **202** in FIG. 2 shows the T-V characteristic of another sub-pixel. By combining the two different T-V characteristics of line **201** and line **202**, a monotonic T-V characteristic can be realized, as shown by the line **203** in FIG. 2.

Therefore, a pixel unit with two sub pixels and drive method thereof are required.

SUMMARY OF THE INVENTION

One object of the present invention is to provide a liquid crystal display with a wide view angle.

Another object of the present invention is to provide a pixel with two sub pixels.

One aspect of the present invention is directed to a liquid crystal display with a plurality of pixel unit that may be drove by a drive wave to form two different pixel electrode voltages in a pixel unit.

Another aspect of the present invention is directed to a method for driving a liquid crystal display with a plurality of pixel unit, wherein each pixel unit has two sub pixels.

Accordingly, the present invention provides a liquid crystal display, comprising: a plurality of data lines; a plurality of scan lines crossing the data lines, wherein the scan lines are grouped into a first group and a second group, and scan lines of the first group and scan lines of the second group are alternatively arranged; a plurality of pixels defined by two neighboring data lines and two neighboring scan lines crossing the two neighboring data lines; a plurality of first switching devices disposed in first sub-pixels respectively; a plurality of second switching devices electrically coupled to corresponding data lines through the first switching devices respectively; and a plurality of pixel electrodes electrically coupled to the first and second switching devices respectively.

In one embodiment of the present invention, the liquid crystal display further comprises a plurality of third switching devices disposed in first sub-pixels, wherein the third switching devices are coupled to corresponding data lines through the first switching devices.

The present invention provides a drive method for driving the above liquid crystal display comprising: providing pulse signals to drive the scan lines sequentially, wherein two pulse signals providing to adjacent scan lines partially overlap; and providing two-step signals to the data lines sequentially, the two-step signal includes a first voltage signal and a second voltage signal, wherein the first voltage signal is written to the first sub-pixel through the first transistor when the first and second scan line are driven together, and the second voltage signal is written to the second sub-pixel through adjacent sub-pixel's first transistor and the second transistor when the second scan line and adjacent pixel's first scan line are driven.

According to one embodiment of the present invention, the first signal and the second signal are pulse signals.

According another embodiment of the present invention, the first signal is a pulse signal and the second signal is a clock signal.

Accordingly, a pixel unit in the present invention is divided into two sub-pixels. Each sub-pixel includes a transistor, a liquid crystal capacitor and a storage capacitor. The two transistors respectively located in different sub-pixels are connected to different scan lines. One of the two transistors is connected to the data line through another transistor. Therefore, two different pixel voltages are formed in a pixel.

BRIEF DESCRIPTION OF THE DRAWINGS

The foregoing aspects and many of the attendant advantages of this invention are more readily appreciated and better understood by referencing the following detailed description, when taken in conjunction with the accompanying drawings, where:

FIG. 1 and FIG. 2 illustrate the transmittance-voltage (T-V) characteristic of MVA mode liquid crystal display;

FIG. 3 illustrates a top view of a liquid crystal display according to the first embodiment of the present invention;

FIG. 4A illustrates a drive waveform and the corresponding electric voltage of four adjacent sub pixels according to the first embodiment of the present invention;

FIG. 4B illustrates another drive waveform and the corresponding electric voltage of four adjacent sub pixels according to the first embodiment of the present invention;

FIG. 5 illustrates a top view of a liquid crystal display according to the second embodiment of the present invention; and

FIG. 6 illustrates a drive waveform and the corresponding electric voltage of four adjacent sub pixels according to the second embodiment of the present invention.

DETAILED DESCRIPTION OF THE PREFERRED EMBODIMENT

FIG. 3 illustrates a top view of a liquid crystal display according to the first embodiment of the present invention. The liquid crystal display is composed of data lines $D_1, D_2, D_3, \dots, D_n$, the scan lines $G_1(A), G_2(A), G_3(A), \dots, G_n(A)$ of group A and the scan lines $G_2(B), G_3(B), \dots, G_{n-1}(B)$ of group B. These scan lines are arranged in parallel to each other. Moreover, the scan lines of group A and the scan lines of group B are alternatively formed over a substrate (not shown in FIG. 3). A data line drive integrated circuit 501 is used to control the data lines $D_1, D_2, D_3, \dots, D_n$. A scan line drive integrated circuit 502 is used to control the scan lines $G_1(A), G_2(A), G_3(A), \dots, G_n(A)$ of group A and the scan lines $G_2(B), G_3(B), \dots, G_{n-1}(B)$ of group B.

The data lines and the scan lines are perpendicular to each other. Adjacent two data lines and adjacent two scan lines respectively belong to the group A and group B define a pixel unit. Each pixel includes a common electrode V_{com} parallel to the scan line. According to the present invention, two transistors are connected to the scan line of group B located between adjacent two pixels to control the data of the data line to transfer to the corresponding pixel.

According to the present invention, a pixel includes two sub-pixels to present different pixel voltage to release the color shift phenomenon. For example, adjacent two data lines D_{n-2} and D_{n-1} and adjacent two scan lines $G_{n-2}(B)$ and $G_{n-1}(A)$ define the pixel 501. A common electrode V_{com} located between and parallel to the scan lines $G_{n-2}(B)$ and $G_{n-1}(A)$. The pixel 503 is divided into two sub-pixels 5031 and 5032. The sub-pixel 5031 is located between the scan line $G_{n-2}(B)$ and the common electrode V_{com} . The sub-pixel 5032 is located between the scan line $G_{n-1}(A)$ and the common electrode V_{com} .

The sub-pixel 5031 includes two transistors Q_1 and Q_2 . According to the embodiment, the gate electrodes of the two transistors Q_1 and Q_2 are connected to the scan line $G_{n-2}(B)$. The first source/drain electrode of the transistor Q_1 is connected to the data line D_{n-1} and the second source/drain electrode of the transistor Q_1 is connected to the first source/drain electrode of the transistor Q_2 . The second source/drain electrode of the transistor Q_2 is connected to the pixel electrode P_1 . The storage capacitor C_{st1} is composed of the pixel electrode P_1 and the common electrode V_{com} . The liquid crystal capacitor C_{LC1} is composed of the pixel electrode P_1 and the conductive electrode in the upper substrate (not shown).

The sub-pixel 5032 also includes a transistor Q_3 . According to the transistor Q_3 , the gate electrode is connected to the scan line $G_{n-1}(A)$, the first source/drain electrode is connected to the common connection point of the transistor Q_5 and Q_6 located in the sub-pixel 5033 and the second source/drain electrode is connected to the pixel electrode P_2 . The storage capacitor C_{st2} is composed of the pixel electrode P_2 and the common electrode V_{com} . The liquid crystal capacitor C_{LC2} is composed of the pixel electrode P_2 and the conductive electrode in the upper substrate (not shown). In other words, the transistor Q_3 is connected to the data line D_{n-1} through the transistor Q_5 .

The transistors Q_1 and Q_2 act as switches. When a scan voltage is applied to the gate electrodes of the transistors Q_1 and Q_2 , the data in the data line is transferred to the second source/drain electrode and is written into the corresponding storage capacitor C_{st1} and the liquid crystal capacitor C_{LC1} through the transistors Q_1 and Q_2 . In other words, the transistors Q_1 and Q_2 together determine whether or not the sub-pixel 5031 should present the data voltage in the data line.

On the other hand, the transistors Q_5 and Q_3 act as switches. When a scan voltage is applied to the gate electrodes of the transistors Q_3 and Q_5 , the data in the data line is transferred to the second source/drain electrode of the transistor Q_3 through the transistor Q_5 and is written into the corresponding storage capacitor C_{st2} and the liquid crystal capacitor C_{LC2} . In other words, the transistors Q_3 and Q_5 together determine whether or not the sub-pixel 5032 should present the data voltage in the data line.

FIG. 4A illustrates a drive waveform and the corresponding electric voltage of four adjacent sub pixels according to an embodiment of the present invention. The drive signal of each scan line is pulse. When scanning, drive signal is sequentially transferred to these scan lines. The time difference between the two drive signals transferred to adjacent scan lines respectively is half period of the pulse. In other words, the two drive signals transferred to adjacent scan lines respectively partially overlap. Therefore, in the time period of the two drive signals overlapping, the transistors connected with the two scan lines are turned on together.

In this embodiment, the drive waveform of the data line is a two steps drive waveform. The positive part of this drive waveform includes two drive voltage V_a and V_b . The negative part of this drive waveform also includes two drive voltage $-V_a$ and $-V_b$. The absolute value of the drive voltage V_a is larger than the absolute value of the drive voltage V_b .

Referring to FIGS. 3 and 4A, during the time segment t_1 , the voltage state of both the scan line $G_{n-2}(A)$ and $G_{n-2}(B)$ are in a high level state. The voltage state of both the scan line $G_{n-1}(A)$ and $G_{n-1}(B)$ are in a low level state. Therefore, the transistors Q_1, Q_2 and Q_4 are turned on and the transistors Q_3, Q_5 and Q_6 are turned off. In this case, the voltage $-V_b$ in the data line D_{n-1} may charge the liquid crystal capacitors C_{LC0} and the storage capacitors C_{st0} through the transistors Q_1 and Q_4 . At this time, the sub-pixel 5030 may present the pixel voltage, $-V_b$. Moreover, the voltage $-V_b$ in the data line D_{n-1} may charge the liquid crystal capacitors C_{LC1} and the storage capacitors C_{st1} through the transistors Q_1 and Q_2 . At this time, the sub-pixel 5031 may also present the pixel voltage, $-V_b$. The transistors Q_3, Q_5 and Q_6 are turned off. Therefore, the pixel voltage of the sub-pixels 5032 and 5033 is not changed. In this embodiment, the sub-pixel 5032 presents the pixel voltage, $-V_b$. The sub-pixel 5033 presents the pixel voltage, V_a .

During the time segment t_2 , the voltage state of both the scan line $G_{n-2}(B)$ and $G_{n-1}(A)$ are in a high level state. The voltage state of both the scan line $G_{n-2}(A)$ and $G_{n-1}(B)$ are in a low level state. Therefore, the transistors Q_1, Q_2 and Q_3 are turned on and the transistors Q_4, Q_5 and Q_6 are turned off. In this case, the voltage $+V_a$ in the data line D_{n-1} may charge the liquid crystal capacitor C_{LC1} and the storage capacitor C_{st1} through the transistor Q_1 . At this time, the sub-pixel 5031 may present the pixel voltage, $+V_a$. On the other hand, the transistors Q_4, Q_5 and Q_6 are turned off. Because the transistors Q_4 is turned off, the liquid crystal capacitor C_{LC0} and the storage capacitor C_{st0} are not charged by the voltage $+V_a$. At this time, the sub-pixel 5030 still presents the pixel voltage, $-V_b$. Because the transistors Q_5 is turned off and the transistors Q_3 is connected to the data line D_{n-1} through the transistors Q_5 , the liquid crystal capacitors C_{LC2} and the storage capacitors C_{st2} are not charged by the voltage $+V_a$. At this time, the sub-pixel 5032 still present the pixel voltage, $-V_b$. Because the transistors Q_5 and Q_6 are turned off, the liquid crystal capacitors C_{LC3} and the storage capacitors C_{st3} are not charged by the voltage $+V_a$. At this time, the sub-pixel 5033 still presents the pixel voltage, $+V_a$.

During the time segment t_3 , the voltage state of both the scan line $G_{n-1}(A)$ and $G_{n-1}(B)$ are in a high level state. The voltage state of both the scan line $G_{n-2}(A)$ and $G_{n-2}(B)$ are in a low level state. Therefore, the transistors Q_3 , Q_5 and Q_6 are turned on and the transistors Q_1 , Q_2 and Q_4 are turned off. In this case, the voltage $+Vb$ in the data line D_{n-1} may charge the liquid crystal capacitor C_{LC2} and the storage capacitor C_{st2} through the transistors Q_3 and Q_5 . At this time, the sub-pixel **5032** may present the pixel voltage, $+Vb$. On the other hand, the voltage $+Vb$ in the data line D_{n-1} may charge the liquid crystal capacitor C_{LC3} and the storage capacitor C_{st3} through the transistors Q_5 and Q_6 . At this time, the sub-pixel **5033** may present the pixel voltage, $+Vb$. Because the transistor Q_4 is turned off, the liquid crystal capacitor C_{LC0} and the storage capacitor C_{st0} are not charged by the voltage $+Vb$. At this time, the sub-pixel **5030** still presents the pixel voltage, $-Vb$. On the other hand, because the transistor Q_1 is turned off and the transistors Q_2 is connected to the data line D_{n-1} through the transistors Q_1 , the liquid crystal capacitors C_{LC1} and the storage capacitors C_{st1} are not charged by the voltage $+Vb$. At this time, the sub-pixel **5031** still presents the pixel voltage, $+Va$.

During the time segment t_4 , the voltage state of the scan line $G_{n-1}(B)$ is in a high level state. The voltage state of both the scan line $G_{n-1}(A)$, $G_{n-2}(A)$ and $G_{n-2}(B)$ are in a low level state. Therefore, the transistors Q_5 and Q_6 are turned on and the transistors Q_1 , Q_2 , Q_3 and Q_4 are turned off. In this case, the voltage $-Va$ in the data line D_{n-1} may charge the liquid crystal capacitor C_{LC3} and the storage capacitor C_{st3} through the transistors Q_5 and Q_6 . At this time, the sub-pixel **5033** may present the pixel voltage, $-Va$. Because the transistors Q_3 and Q_4 are turned off, the liquid crystal capacitor C_{LC0} and the storage capacitor C_{st0} are not charged by the voltage $-Vb$. At this time, the sub-pixel **5030** still presents a pixel voltage, $-Vb$. Because the transistors Q_1 and Q_4 are turned off, the liquid crystal capacitors C_{LC0} and the storage capacitors C_{st0} are not charged by the voltage $-Va$. At this time, the sub-pixel **5030** still presents the pixel voltage, $-Vb$. Because the transistors Q_1 and Q_2 are turned off, the liquid crystal capacitors C_{LC1} and the storage capacitors C_{st1} are not charged by the voltage $-Va$. At this time, the sub-pixel **5031** still presents the pixel voltage, $+Va$. Because the transistor Q_3 is turned off, the liquid crystal capacitors C_{LC2} and the storage capacitors C_{st2} are not charged by the voltage $-Va$. At this time, the sub-pixel **5032** still presents the pixel voltage, $+Vb$.

Accordingly, from the time segment t_1 to t_4 , at least two pixel voltages, Vb and $+Va$, are presented in the pixel **503** together. Different pixel voltage may present different optical characteristics. Therefore, the color shift phenomenon may be eased by combining the two pixel voltages in a pixel.

FIG. 4B illustrates a drive waveform and the corresponding electric voltage of four adjacent sub pixels according to another embodiment of the present invention. The drive signal transferred in the scan line of the group A is a clock signal. The drive signal transferred in the scan line of the group B is pulse signal. When scanning, pulse signal is sequentially transferred to these scan lines of the group B. The pulse width is equal to the period the clock signal. In other words, the two drive signals, the clock signal and the pulse signal, transferred to adjacent scan lines respectively partially overlap. Therefore, in the time period of the two drive signals overlapping, the transistors connected with the two scan lines are turned on together.

In this embodiment, the drive waveform of the data line is a two steps drive waveform. The positive part of this drive waveform includes two drive voltage Va and Vb . The negative part of this drive waveform also includes two drive voltage

$-Va$ and $-Vb$. The absolute value of the drive voltage Va is larger than the absolute value of the drive voltage Vb .

Referring to FIGS. 3 and 4B, during the time segment t_1 , the voltage state of the scan line $G_{n-1}(A)$, $G_{n-2}(A)$ and $G_{n-2}(B)$ are in a high level state. The voltage state of the scan line $G_{n-1}(B)$ is in a low level state. Therefore, the transistors Q_1 , Q_2 , Q_3 and Q_4 are turned on and the transistors Q_5 and Q_6 are turned off. In this case, the voltage $-Vb$ in the data line D_{n-1} may charge the liquid crystal capacitors C_{LC0} and the storage capacitors C_{st0} through the transistors Q_3 and Q_4 . At this time, the sub-pixel **5030** may present the pixel voltage, $-Vb$. Moreover, the voltage $-Vb$ in the data line D_{n-1} may charge the liquid crystal capacitors C_{LC1} and the storage capacitors C_{st1} through the transistors Q_1 and Q_2 . At this time, the sub-pixel **5031** may also present the pixel voltage, $-Vb$. The transistors Q_5 and Q_6 are turned off. The transistor Q_3 is connected to the data line D_{n-1} through the transistors Q_5 . Therefore, the liquid crystal capacitor C_{LC2} and the storage capacitor C_{st2} are not charged by the voltage $-Vb$. On the other hand, because the transistor Q_6 is turned off, the liquid crystal capacitors C_{LC3} and the storage capacitors C_{st3} are not charged by the voltage $-Vb$. Therefore, the sub-pixel **5032** and the sub-pixel **5033** still present the pixel voltage of the previous state. In this embodiment, the sub-pixel **5032** presents the pixel voltage, $-Vb$. The sub-pixel **5033** presents the pixel voltage, Va .

During the time segment t_2 , the voltage state of both the scan line $G_{n-2}(B)$ is in a high level state. The voltage state of the scan lines $G_{n-1}(A)$, $G_{n-2}(A)$ and $G_{n-1}(B)$ are in a low level state. Therefore, the transistors Q_1 and Q_2 are turned on and the transistors Q_3 , Q_4 , Q_5 and Q_6 are turned off. In this case, the voltage $+Va$ in the data line D_{n-1} may charge the liquid crystal capacitor C_{LC1} and the storage capacitor C_{st1} through the transistors Q_1 and Q_2 . At this time, the sub-pixel **5031** may present the pixel voltage, $+Va$. On the other hand, because the transistor Q_4 is turned off, the liquid crystal capacitor C_{LC0} and the storage capacitor C_{st0} are not charged by the voltage $+Va$. At this time, the sub-pixel **5030** still presents the previous pixel voltage state, $-Vb$. Because the transistor Q_3 is turned off, the liquid crystal capacitors C_{LC2} and the storage capacitors C_{st2} are not charged by the voltage $+Va$. At this time, the sub-pixel **5032** still present the previous pixel voltage state, $-Vb$. Because the transistor Q_6 is turned off, the liquid crystal capacitors C_{LC3} and the storage capacitors C_{st3} are not charged by the voltage $+Va$. At this time, the sub-pixel **5033** still presents the previous pixel voltage state, $+Va$.

During the time segment t_3 , the voltage state of the scan line $G_{n-1}(A)$, $G_{n-2}(A)$ and $G_{n-1}(B)$ are in a high level state. The voltage state of the scan line $G_{n-2}(B)$ is in a low level state. Therefore, the transistors Q_3 , Q_4 , Q_5 and Q_6 are turned on and the transistors Q_1 , Q_2 and are turned off. In this case, the voltage $+Vb$ in the data line D_{n-1} may charge the liquid crystal capacitor C_{LC2} and the storage capacitor C_{st2} through the transistors Q_3 and Q_5 . At this time, the sub-pixel **5032** may present the pixel voltage, $+Vb$. On the other hand, the voltage $+Vb$ in the data line D_{n-1} may charge the liquid crystal capacitor C_{LC3} and the storage capacitor C_{st3} through the transistors Q_5 and Q_6 . At this time, the sub-pixel **5033** may present the pixel voltage, $+Vb$. Because the transistor Q_1 is turned off and the transistor Q_4 is coupled to the data line D_{n-1} through the transistor Q_1 , the liquid crystal capacitors C_{LC0} and the storage capacitors C_{st0} are not charged by the voltage $+Vb$. At this time, the sub-pixel **5030** still present the pixel voltage, $-Vb$. On the other hand, because the transistors Q_1 and Q_2 are turned off, the liquid crystal capacitor C_{LC1} and the storage capacitor C_{st1} are not charged by the voltage $+Vb$. At this time, the sub-pixel **5031** still presents the pixel voltage, Va .

During the time segment t_4 , the voltage state of the scan line $G_{n-1}(B)$ is in a high level state. The voltage state of both the scan line $G_{n-1}(A)$, $G_{n-2}(A)$ and $G_{n-2}(B)$ are in a low level state. Therefore, the transistors Q_5 and Q_6 are turned on and the transistors Q_1 , Q_2 , Q_3 and Q_4 are turned off. In this case, the voltage $-Vb$ in the data line D_{n-1} may charge the liquid crystal capacitor C_{LC3} and the storage capacitor C_{st3} through the transistors Q_5 and Q_6 . At this time, the sub-pixel **5033** may present the pixel voltage, $-Vb$. Because the transistor Q_4 is turned off, the liquid crystal capacitor C_{LC0} and the storage capacitor C_{st0} are not charged by the voltage $-Vb$. At this time, the sub-pixel **5030** still presents the previous pixel voltage state, $-Vb$. Because the transistors Q_1 and Q_2 are turned off, the liquid crystal capacitors C_{LC1} and the storage capacitors C_{st1} are not charged by the voltage $-Vb$. At this time, the sub-pixel **5031** still presents the previous pixel voltage state, $+Va$. Because the transistor Q_3 is turned off, the liquid crystal capacitors C_{LC2} and the storage capacitors C_{st2} are not charged by the voltage $-Vb$. At this time, the sub-pixel **5032** still presents the previous pixel voltage state, $+Vb$.

Accordingly, from the time segment t_1 to t_4 , at least two pixel voltages, Vb and $+Va$, are presented in the pixel **503** together. Different pixel voltage may present different optical characteristics. Therefore, the color shift phenomenon may be eased by combining the two pixel voltages in a pixel.

FIG. 5 illustrates a top view of a liquid crystal display according to the second embodiment of the present invention. The Liquid crystal display is composed of data lines D_1 , D_2 , D_3 , . . . , D_n , the scan lines $G_1(A)$, $G_2(A)$, $G_3(A)$, . . . , $G_n(A)$ of group A and the scan lines $G_2(B)$, $G_3(B)$, . . . , $G_{n-1}(B)$ of group B. These scan lines are arranged in parallel to each other. Moreover, the scan lines of group A and the scan lines of group B are alternatively formed over a substrate (not shown). A data line drive integrated circuit **701** is used to control the data lines D_1 , D_2 , D_3 , . . . , D_n . A scan line drive integrated circuit **702** is used to control the scan lines $G_1(A)$, $G_2(A)$, $G_3(A)$, . . . , $G_n(A)$ of group A and the scan lines $G_2(B)$, $G_3(B)$, . . . , $G_{n-1}(B)$ of group B. The data lines and the scan lines are perpendicular to each other. Adjacent two data lines and adjacent two scan lines respectively belong to the group A and group B define a pixel unit. Each pixel includes a common electrode V_{com} parallel to the scan line.

According to the present invention, a pixel includes two sub-pixels to present different pixel voltage to release the color shift phenomenon. For example, adjacent two data lines D_{n-2} and D_{n-1} and adjacent two scan lines $G_{n-2}(B)$ and $G_{n-1}(A)$ define the pixel **701**. A common electrode V_{com} located between and parallel to the scan lines $G_{n-2}(B)$ and $G_{n-1}(A)$. The pixel **703** is divided into two sub-pixels **7031** and **7032**. The sub-pixel **7031** is located between the scan line $G_{n-2}(B)$ and the common electrode V_{com} . The sub pixel **7032** is located between the scan line $G_{n-1}(A)$ and the common electrode V_{com} .

The sub-pixel **7031** includes one transistor Q_1 . According to the embodiment, the gate electrodes of the transistor Q_1 is connected to the scan line $G_{n-2}(B)$. The first source/drain electrode of the transistor Q_1 is connected to the data line D_{n-1} and the second source/drain electrode of the transistor Q_1 is connected to the pixel electrode P_1 . The storage capacitor C_{st1} is composed of the pixel electrode P_1 and the common electrode V_{com} . The liquid crystal capacitor C_{LC1} is composed of the pixel electrode P_1 and the conductive electrode in the upper substrate (not shown).

The sub-pixel **7032** also includes a transistor Q_2 . According to the transistor Q_2 , the gate electrode is connected to the scan line $G_{n-1}(A)$, the first source/drain electrode is connected to the transistor Q_4 located in the sub-pixel **7033** and the

second source/drain electrode is connected to the pixel electrode P_2 . The storage capacitor C_{st2} is composed of the pixel electrode P_2 and the common electrode V_{com} . The liquid crystal capacitor C_{LC2} is composed of the pixel electrode P_2 and the conductive electrode in the upper substrate (not shown). In other words, the transistor Q_2 is connected to the data line D_{n-1} through the transistor Q_4 .

The transistor Q_1 acts as a switch. When a scan voltage is applied to the gate electrodes of the transistor Q_1 , the data in the data line is transferred to the second source/drain electrode and is written into the corresponding storage capacitor C_{st1} and the liquid crystal capacitor C_{LC1} through the transistor Q_1 . In other words, the transistor Q_1 determine whether or not the sub-pixel **7031** should present the data voltage in the data line.

On the other hand, the transistors Q_2 and Q_4 act as switches. When a scan voltage is applied to the gate electrodes of the transistors Q_2 and Q_4 , the data in the data line is transferred to the second source/drain electrode of the transistor Q_2 through the transistor Q_4 and is written into the corresponding storage capacitor C_{st2} and the liquid crystal capacitor C_{LC2} . In other words, the transistors Q_2 and Q_4 together determine whether or not the sub-pixel **7032** should present the data voltage in the data line.

FIG. 6 illustrates a drive waveform and the corresponding electric voltage of four adjacent sub pixels according to an embodiment of the present invention. The drive signal of each scan line is pulse. When scanning, drive signal is sequentially transferred to these scan lines. The time difference between the two drive signals transferred to adjacent scan lines respectively is half period of the pulse. In other words, the two drive signals transferred to adjacent scan lines respectively partially overlap. Therefore, in the time period of the two drive signals overlapping, the transistors connected with the two scan lines are turned on together.

In this embodiment, the drive waveform of the data line is a two steps drive waveform. The positive part of this drive waveform includes two drive voltage Va and Vb . The negative part of this drive waveform also includes two drive voltage $-Va$ and $-Vb$. The absolute value of the drive voltage Va is larger than the absolute value of the drive voltage Vb .

Referring to FIGS. 5 and 6, during the time segment t_1 , the voltage state of both the scan line $G_{n-2}(A)$ and $G_{n-2}(B)$ are in a high level state. The voltage state of both the scan line $G_{n-1}(A)$ and $G_{n-1}(B)$ are in a low level state. Therefore, the transistors Q_1 and Q_3 are turned on and the transistors Q_2 and Q_4 are turned off. In this case, the voltage $-Vb$ in the data line D_{n-1} may charge the liquid crystal capacitors C_{LC0} and the storage capacitors C_{st0} through the transistors Q_1 and Q_3 . At this time, the sub-pixel **7030** may present the pixel voltage, $-Vb$. Moreover, the voltage $-Vb$ in the data line D_{n-1} may charge the liquid crystal capacitors C_{LC1} and the storage capacitors C_{st1} through the transistor Q_1 . At this time, the sub-pixel **7031** may also present the pixel voltage, $-Vb$. The transistors Q_2 and Q_4 are turned off. Therefore, the pixel voltage of the sub-pixels **7032** and **7033** are not changed. In this embodiment, the sub-pixel **7032** presents the pixel voltage, $-Vb$. The sub-pixel **7033** presents the pixel voltage, Va .

During the time segment t_2 , the voltage state of both the scan line $G_{n-2}(B)$ and $G_{n-1}(A)$ are in a high level state. The voltage state of both the scan line $G_{n-2}(A)$ and $G_{n-1}(B)$ are in a low level state. Therefore, the transistors Q_1 and Q_2 are turned on and the transistors Q_3 and Q_4 are turned off. In this case, the voltage $+Va$ in the data line D_{n-1} may charge the liquid crystal capacitor C_{LC1} and the storage capacitor C_{st1} through the transistor Q_1 . At this time, the sub-pixel **7031** may present the pixel voltage, $+Va$. On the other hand, the transis-

tors Q_4 and Q_3 are turned off. Because the transistors Q_3 is turned off, the liquid crystal capacitor C_{LC0} and the storage capacitor C_{S0} are not charged by the voltage $+V_a$. At this time, the sub-pixel **7030** still presents the pixel voltage, $-V_b$. Because the transistors Q_4 is turned off and the transistors Q_2 is connected to the data line D_{n-1} through the transistors Q_4 , the liquid crystal capacitors C_{LC2} and the storage capacitors C_{S2} are not charged by the voltage $+V_a$. At this time, the sub-pixel **7032** still present the pixel voltage, $-V_b$. Because the transistor Q_4 is turned off, the liquid crystal capacitors C_{LC3} and the storage capacitors C_{S3} are not charged by the voltage $+V_a$. At this time, the sub-pixel **7033** still presents the pixel voltage, $+V_a$.

During the time segment t_3 , the voltage state of both the scan line $G_{n-1}(A)$ and $G_{n-1}(B)$ are in a high level state. The voltage state of both the scan line $G_{n-2}(A)$ and $G_{n-2}(B)$ are in a low level state. Therefore, the transistors Q_2 , and Q_4 are turned on and the transistors Q_1 and Q_3 are turned off. In this case, the voltage $+V_b$ in the data line D_{n-1} may charge the liquid crystal capacitor C_{LC2} and the storage capacitor C_{S2} through the transistors Q_2 and Q_4 . At this time, the sub-pixel **7032** may present the pixel voltage, $+V_b$. On the other hand, the voltage $+V_b$ in the data line D_{n-1} may charge the liquid crystal capacitor C_{LC3} and the storage capacitor C_{S3} through the transistor Q_4 . At this time, the sub-pixel **7033** may present the pixel voltage, $+V_b$. Because the transistor Q_3 is turned off, the liquid crystal capacitor C_{LC0} and the storage capacitor C_{S0} are not charged by the voltage $+V_b$. At this time, the sub-pixel **7030** still presents the pixel voltage, $-V_b$. On the other hand, because the transistor Q_1 is turned off and the transistors Q_2 is connected to the data line D_{n-1} through the transistors Q_1 , the liquid crystal capacitors C_{LC1} and the storage capacitors C_{S1} are not charged by the voltage $+V_b$. At this time, the sub-pixel **7031** still presents the pixel voltage, $+V_a$.

During the time segment t_4 , the voltage state of the scan line $G_{n-1}(B)$ is in a high level state. The voltage state of both the scan line $G_{n-1}(A)$, $G_{n-2}(A)$ and $G_{n-2}(B)$ are in a low level state. Therefore, the transistor Q_4 is turned on and the transistors Q_1 , Q_2 and Q_3 are turned off. In this case, the voltage $-V_a$ in the data line D_{n-1} may charge the liquid crystal capacitor C_{LC3} and the storage capacitor C_{S3} through the transistor Q_4 . At this time, the sub-pixel **7033** may present the pixel voltage, $-V_a$. Because the transistor Q_3 is turned off, the liquid crystal capacitor C_{LC0} and the storage capacitor C_{S0} are not charged by the voltage $-V_b$. At this time, the sub-pixel **7030** still presents a pixel voltage, $-V_b$. Because the transistor Q_1 is turned off, the liquid crystal capacitors C_{LC1} and the storage capacitors C_{S1} are not charged by the voltage $-V_a$. At this time, the sub-pixel **7031** still presents the pixel voltage, V_a . Because the transistor Q_2 is turned off, the liquid crystal capacitors C_{LC2} and the storage capacitors C_{S2} are not charged by the voltage $-V_a$. At this time, the sub-pixel **7032** still presents the pixel voltage, $+V_b$.

Accordingly, from the time segment t_1 to t_4 , at least two pixel voltages, V_b and $+V_a$, are presented in the pixel **703** together. Different pixel voltage may present different optical characteristics. Therefore, the color shift phenomenon may be eased by combining the two pixel voltages in a pixel.

Accordingly, a pixel unit in the present invention is divided into two sub-pixels. Each sub-pixel includes a thin film transistor, a liquid crystal capacitor and a storage capacitor. The two transistors in a pixel are connected to different scan lines. One of the two transistors is connected to the data line through another transistor. Therefore, two different pixel voltages are formed in a pixel. The color shift phenomenon may be eased by combining the two pixel voltages in a pixel.

As is understood by a person skilled in the art, the foregoing descriptions of the preferred embodiment of the present invention are an illustration of the present invention rather than a limitation thereof. Various modifications and similar arrangements are included within the spirit and scope of the appended claims. The scope of the claims should be accorded to the broadest interpretation so as to encompass all such modifications and similar structures.

What is claimed is:

1. A liquid crystal display, comprising:

a plurality of data lines configured to be provided with two-step signals sequentially, each of the two-step signals comprising a first voltage signal and a second voltage signal different from the first voltage signal;

a plurality of scan lines crossing said data lines, wherein said scan lines are grouped into a first group and a second group, and scan lines of the first group and scan lines of the second group are alternatively arranged;

a plurality of pixels each defined by two neighboring data lines and two neighboring scan lines crossing the two neighboring data lines, the two neighboring scan lines comprising a first scan line in the first group and a second scan line in the second group;

a plurality of common electrodes disposed in corresponding pixels to define said pixels into a plurality of first sub-pixels and a plurality of second sub-pixels;

a plurality of first switching devices respectively disposed in the first sub-pixels and electrically connected to corresponding data lines;

a plurality of second switching devices respectively disposed in the second sub-pixels, electrically connected to corresponding data lines through said first switching devices disposed in the first sub-pixels respectively, wherein the first voltage signal is written to the first sub-pixel in one of said pixels through said first switching device when the first scan line and the second scan line coupled to the same one of said pixels are both driven, and the second voltage signal is written to the second sub-pixel in the same one of said pixels through said second switching device when the second scan line within the same one of said pixels and the first scan line coupled to a next one of said pixels are both driven;

a plurality of first pixel electrodes electrically coupled to said first switching devices respectively, wherein said first pixel electrodes receive data from data lines through said first switching devices; and

a plurality of second pixel electrodes electrically coupled to said second switching devices respectively, wherein said second pixel electrodes receive data from data lines through said first switching devices disposed in the first sub-pixels and said second switching devices disposed in the second sub-pixels.

2. The liquid crystal display of claim 1, further comprising a plurality of third switching devices disposed in said first sub-pixels respectively, wherein said third switching devices are electrically coupled to corresponding data lines through said first switching devices.

3. The liquid crystal display of claim 2, wherein said second switching devices are electrically coupled to said first switching devices and said third switching devices.

4. The liquid crystal display of claim 1, wherein said first switching devices and said second switching devices are transistors.

5. The liquid crystal display of claim 1, wherein said common electrodes and said pixel electrodes form storage capacitors.

6. A liquid crystal display, comprising:
 a plurality of data lines configured to be provided with two-step signals sequentially, each of the two-step signals comprising a first voltage signal and a second voltage signal different from the first voltage signal;
 a plurality of scan lines crossing said data lines;
 a plurality of pixels each defined by two neighboring data lines and two neighboring scan lines crossing the two neighboring data lines, the two neighboring scan lines comprising a first scan line in the first group and a second scan line in the second group, wherein each pixel comprises:
 a first pixel electrode;
 a second pixel electrode;
 a common electrode, wherein said common electrode and said first pixel electrode define a first sub-pixel and said common electrode and said second pixel electrode define a second sub-pixel;
 a first transistor located in said first sub-pixel, a gate electrode of said first transistor is connected to said first scan line, a first source/drain electrode of said first transistor is connected to said first data line and a second source/drain electrode of said first transistor is connected to said first pixel electrode, wherein the first voltage signal is written to said first sub-pixel through said first transistor when said first scan line and said second scan line coupled to the same one of said pixels are both driven; and
 a second transistor located in said second sub-pixel, a gate electrode of said second transistor is connected to said second scan line, a first source/drain electrode of said second transistor is connected to a second source/drain electrode of said first transistor and a second source/drain electrode of said second transistor is connected to said second pixel electrode, wherein said second transistor located in said second sub-pixel is coupled to said first data line through said first transistor located in said first sub-pixel, wherein the second voltage signal is written to said second sub-pixel through said second transistor when said second scan line coupled to the same one of said pixels and said first scan line coupled to a next one of said pixels are both driven.
7. The liquid crystal display of claim 6, further comprising a third transistor located in said first sub-pixel, a gate electrode of said third transistor is connected to said first scan line, a first source/drain electrode of said third transistor is connected to a second source/drain electrode of said first transistor and a second source/drain electrode of said third transistor is connected to said first pixel electrode, wherein said third transistor is coupled to said first data line through said first transistor.
8. The liquid crystal display of claim 7, wherein said second transistor is coupled to a common connection point of said first transistor and said third transistor.
9. The liquid crystal display of claim 6, wherein said common electrode and corresponding pixel electrode form a storage capacitor.

10. A liquid crystal display, comprising:
 a plurality of data lines configured to be provided with two-step signals sequentially, each of the two-step signals comprising a first voltage signal and a second voltage signal different from the first voltage signal;
 a plurality of scan lines crossing said data lines;
 a plurality of pixels each defined by two neighboring data lines and two neighboring scan lines crossing the two neighboring data lines, the two neighboring scan lines comprising a first scan line in the first group and a second scan line in the second group, wherein each pixel comprises:
 a first pixel electrode;
 a second pixel electrode;
 a common electrode, wherein said common electrode and said first pixel electrode define a first sub-pixel and said common electrode and said second pixel electrode define a second sub-pixel;
 a first transistor located in said first sub-pixel, a gate electrode of said first transistor is connected to said first scan line, a first source/drain electrode of said first transistor is connected to said first data line;
 a second transistor located in said first sub-pixel, a gate electrode of said second transistor is connected to said first scan line, a first source/drain electrode of said second transistor is connected to a second source/drain electrode of said first transistor and a second source/drain electrode of said second transistor is connected to said first pixel electrode, wherein said second transistor located in said first sub-pixel is coupled to said first data line through said first transistor located in said first sub-pixel, wherein the first voltage signal is written to said first sub-pixel through said first transistor and said second transistor when said first scan line and said second scan line coupled to the present one of said pixels are both driven; and
 a third transistor located in said second sub-pixel, a gate electrode of said third transistor is connected to said second scan line, a first source/drain electrode of said third transistor is connected to a common connection point of said first transistor and said second transistor and a second source/drain electrode of said third transistor is connected to a second pixel electrode, wherein said third transistor is coupled to said first data line through said first transistor, wherein the second voltage signal is written to said second sub-pixel through said first transistor located in said first sub-pixel of a next one of said pixels and said third transistor located in said second sub-pixel of the present one of said pixels when said second scan line coupled to the present one of said pixels and said first scan line coupled to a next one of said pixels are both driven.
11. The liquid crystal display of claim 10, wherein said common electrode and corresponding pixel electrode form a storage capacitor.

* * * * *

专利名称(译)	液晶显示器及其操作方法		
公开(公告)号	US8098220	公开(公告)日	2012-01-17
申请号	US12/912132	申请日	2010-10-26
[标]申请(专利权)人(译)	友达光电股份有限公司		
申请(专利权)人(译)	友达光电股份有限公司		
当前申请(专利权)人(译)	友达光电股份有限公司		
[标]发明人	CHIANG MIN FENG HUANG HSUEH YING LAI MING SHENG		
发明人	CHIANG, MIN-FENG HUANG, HSUEH-YING LAI, MING-SHENG		
IPC分类号	G09G3/36		
CPC分类号	G09G3/3607 G09G3/3659 G09G2300/0814 G09G2310/0205 G09G2320/028		
审查员(译)	阮箐		
优先权	095131461 2006-08-25 TW		
其他公开文献	US20110037741A1		
外部链接	Espacenet USPTO		

摘要(译)

本发明中的像素单元分为两个子像素。每个子像素包括薄膜晶体管，液晶电容器和存储电容器。分别位于不同子像素中的两个晶体管连接到不同的扫描线。两个晶体管中的一个通过另一个晶体管连接到数据线。因此，在像素中形成两个不同的像素电压。

