



US007724321B2

(12) **United States Patent**
Hsieh et al.

(10) **Patent No.:** **US 7,724,321 B2**
(45) **Date of Patent:** **May 25, 2010**

- (54) **LIQUID CRYSTAL DISPLAY**
- (75) Inventors: **Min-Hsun Hsieh**, Hsinchu (TW);
Chien-Yuan Wang, Hsinchu (TW)
- (73) Assignee: **Epistar Corporation**, Hsinchu (TW)
- (*) Notice: Subject to any disclaimer, the term of this patent is extended or adjusted under 35 U.S.C. 154(b) by 1264 days.
- (21) Appl. No.: **11/233,039**
- (22) Filed: **Sep. 23, 2005**

6,255,670	B1	7/2001	Srivastava et al.
6,278,135	B1	8/2001	Srivastava et al.
6,294,800	B1	9/2001	Duggal et al.
6,679,621	B2	1/2004	West et al.
6,686,691	B1	2/2004	Mueller et al.
6,791,636	B2	9/2004	Paolini et al.
6,809,781	B2	10/2004	Setlur et al.
6,844,903	B2	1/2005	Mueller-Mach et al.
2004/0004988	A1 *	1/2004	Cok et al. 372/70
2004/0061810	A1	4/2004	Lowery et al.
2004/0218390	A1 *	11/2004	Holman et al. 362/245
2005/0001537	A1	1/2005	West et al.
2005/0073495	A1 *	4/2005	Harbers et al. 345/102

(65) **Prior Publication Data**
US 2006/0065900 A1 Mar. 30, 2006

FOREIGN PATENT DOCUMENTS

(30) **Foreign Application Priority Data**

Sep. 24, 2004	(TW)	93129157 A
Feb. 4, 2005	(TW)	94103538 A
May 6, 2005	(TW)	94114630 A
Jun. 29, 2005	(TW)	94121784 A
Aug. 22, 2005	(TW)	94128643 A

JP	06-242726	9/1994
JP	2003-40616	2/2003
TW	528910	4/2003

* cited by examiner

Primary Examiner—Dung Nguyen
Assistant Examiner—Tai Duong
(74) *Attorney, Agent, or Firm*—Rabin & Berdo, PC

- (51) **Int. Cl.**
G02F 1/1335 (2006.01)
G02F 1/13357 (2006.01)
- (52) **U.S. Cl.** **349/68**; 349/62; 349/71;
349/106; 349/113; 362/97.3
- (58) **Field of Classification Search** 349/61,
349/62, 64, 68, 71, 106, 108, 113; 362/84,
362/97.2, 97.3, 231, 249.02; 257/79, 88,
257/89
See application file for complete search history.

(57) **ABSTRACT**

A liquid crystal display having a backlight module, liquid crystal layer and a color filter layer is disclosed in the invention. An ultraviolet unit for emitting ultraviolet is disposed in the backlight module. The color filter layer is composed of a purity of pixels, and at least one of the purity of pixels is filled with a wavelength-converting material. The wavelength-converting material can convert ultraviolet into green light.

- (56) **References Cited**
U.S. PATENT DOCUMENTS
6,252,254 B1 6/2001 Soules et al.

18 Claims, 5 Drawing Sheets

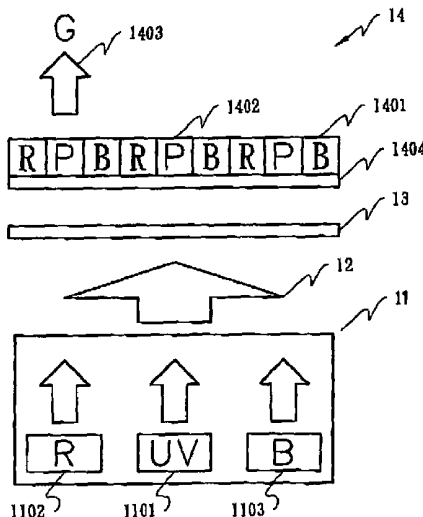

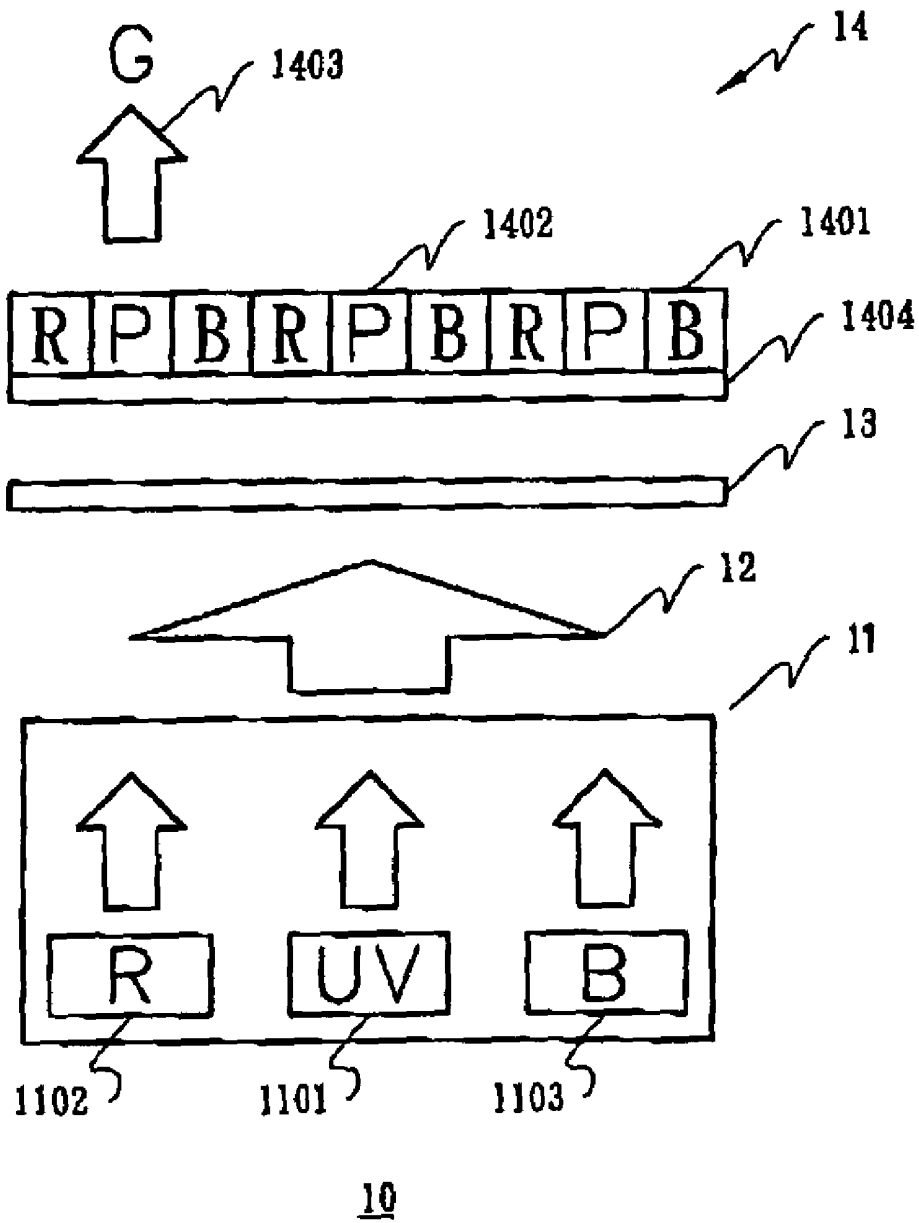

FIG. 1

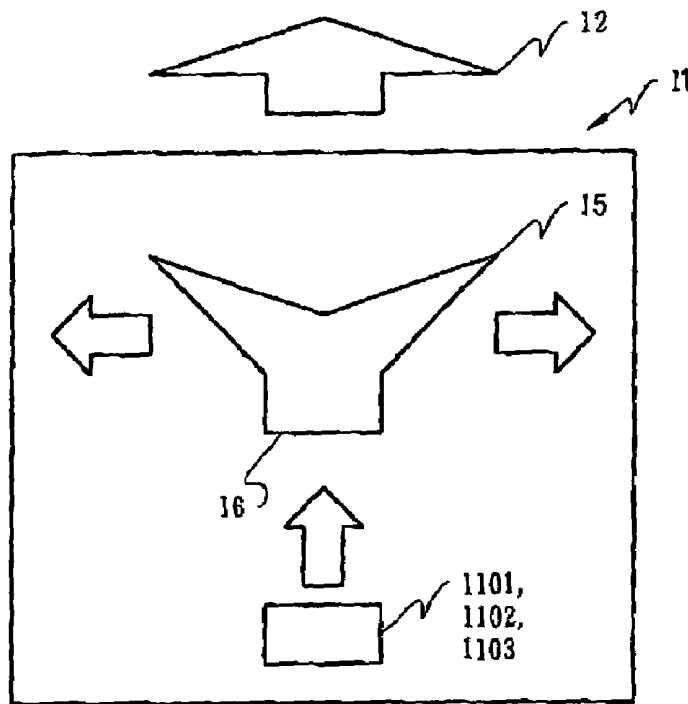

FIG. 2a

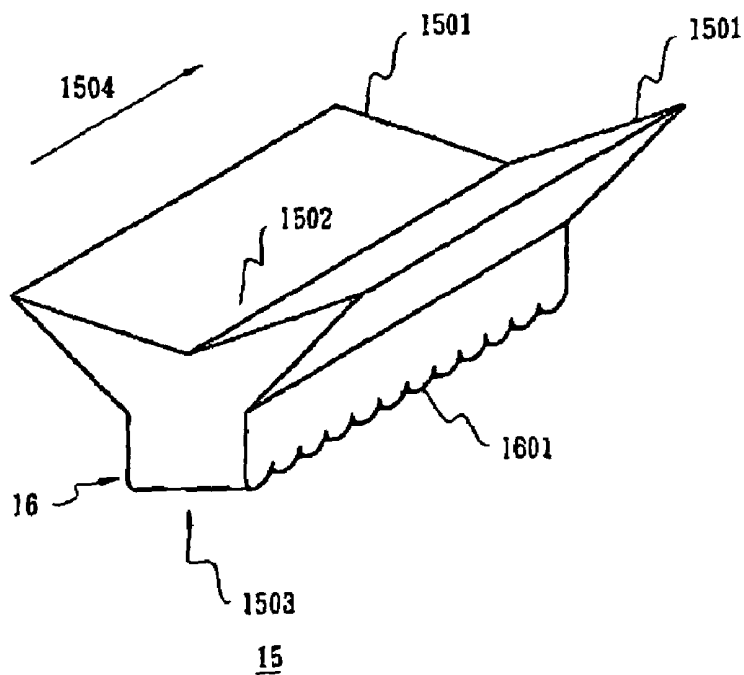

FIG. 2b

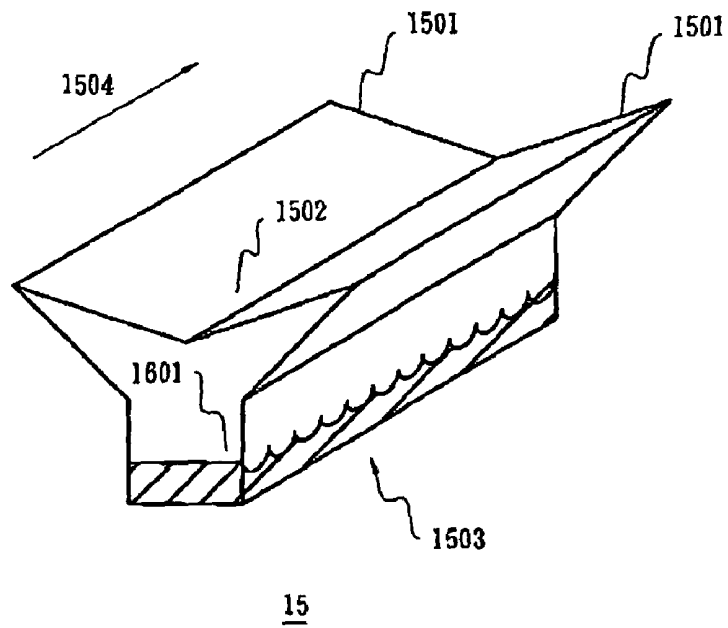

FIG. 2c

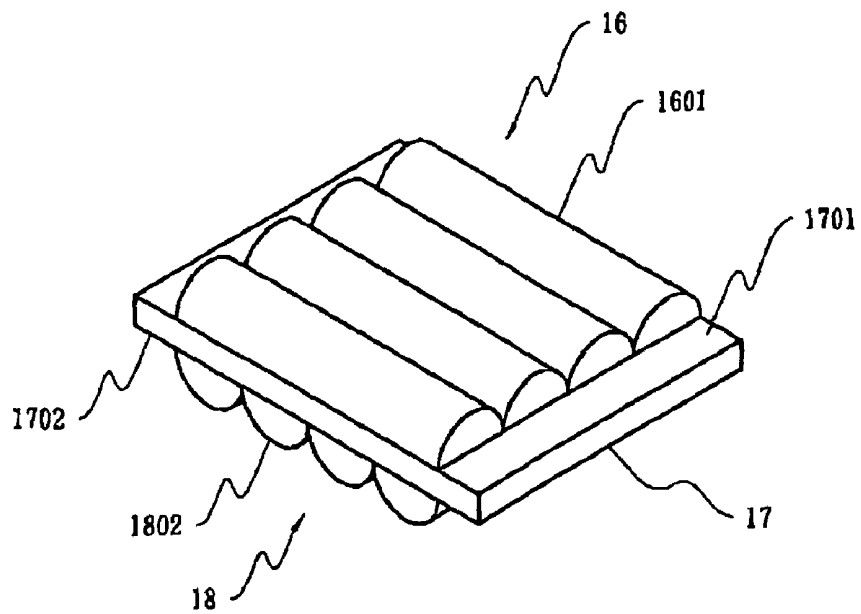

FIG. 2d

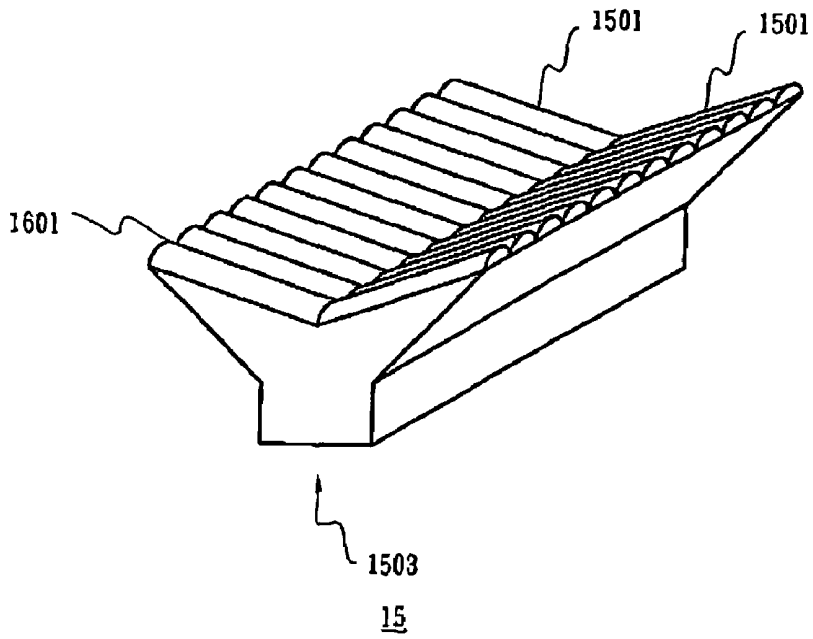

FIG. 2e

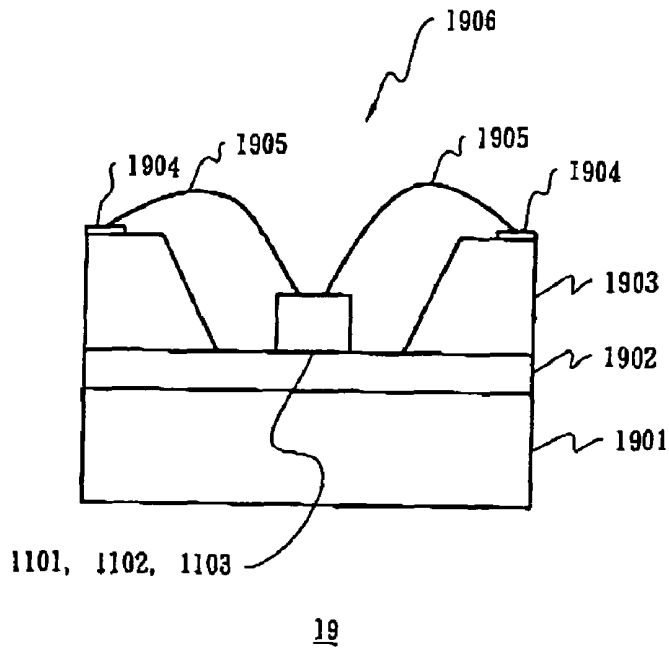

FIG. 3a

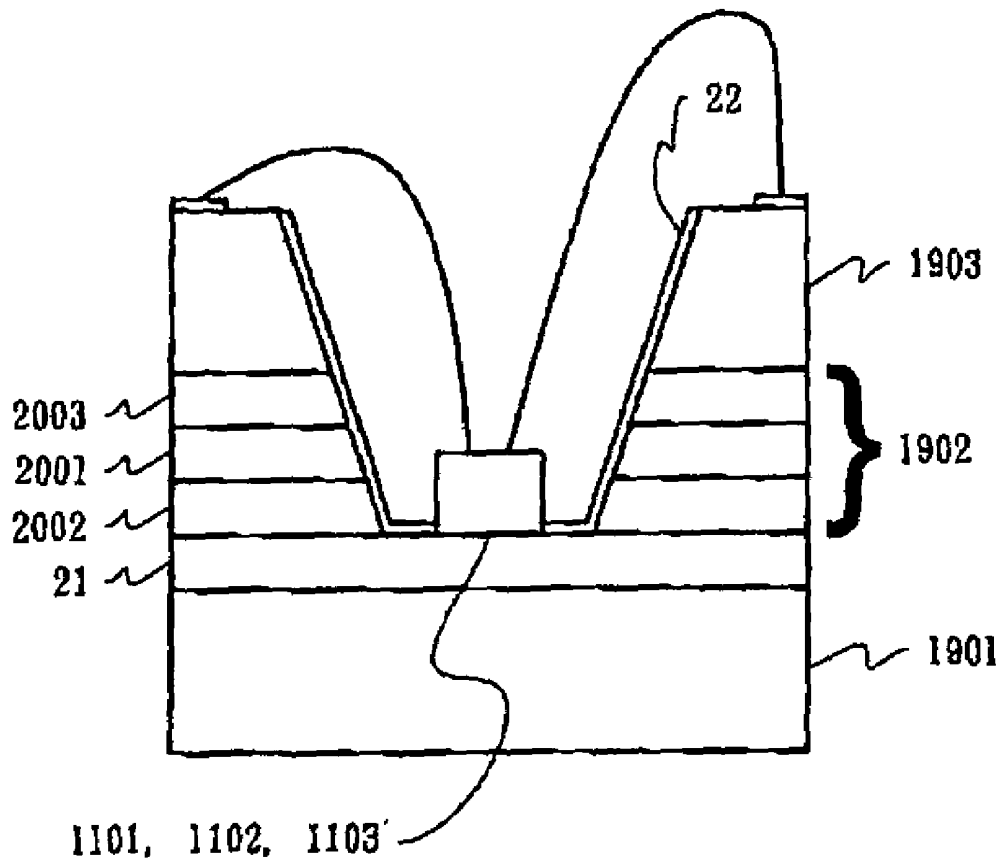

FIG. 3b

LIQUID CRYSTAL DISPLAY

RELATED APPLICATIONS

The present application claims the right of priority based on Taiwan Application Serial Number 093129157, filed Sep. 24, 2004; Taiwan Application Serial Number 094103538, filed Feb. 4, 2005; Taiwan Application Serial Number 094114630, filed May 6, 2005; Taiwan Application Serial Number 094121784, filed Jun. 29, 2005; and Taiwan Application Serial Number 094128643, filed Aug. 22, 2005, the disclosure of which is incorporated herein by reference in their entirety.

FIELD OF THE INVENTION

The present invention relates to a liquid crystal display (LCD) comprising a color filter layer and a backlight module, the backlight module comprising an ultraviolet unit, the color filter layer comprising a wavelength-converting material able to absorb the ultraviolet light emitted from the ultraviolet unit and emit green light.

BACKGROUND OF THE INVENTION

A liquid crystal display belongs to a non-self emitting display, and thus light emitting device is needed to act as a light source. Such a light emitting device is generally called a backlight module. Backlight modules are commonly divided into two types: a direct-light type and an edge-light type. The conventional backlight module uses a lamp tube such as a cold cathode fluorescent lamp (CCFL) as a light source. However, the CCFL fails to regenerate the real colors of objects due to the low color rendering index (CRI).

For better color rendering, a light-emitting diode (LED) is deemed a better solution for the light source of backlight module in the coming market. LEDs offer benefits such as small size, low power consumption, fast response time, long operating time, and durability, etc. A color filter is usually used in the LCD for separating the three primary colors, i.e. red, blue and green from the white light. Mixing the three primary colors in different percentages may create various desired colors.

There are several methods of forming white light by LEDs. (1) A blue LED used with a yellow phosphor, commonly yttrium-aluminum-garnet (YAG) phosphor, is one of the most popular measures forming white light. However, this type of white light is formed by mixing blue light with yellow light, and the spectrum thereof is mainly shown at two wavelengths of 460 nm and 550 nm, i.e. this type of white light lacks of red and green lights, and thus a LCD adopting this type of white light fails to show real color of object. (2) A blue LED is used to excite the red and green phosphors for generating red and green lights. The red light, the green light, and the blue are mixed to form white light. However, there is serious crosstalk among the red, blue and green colors generated by this method, i.e. the bandwidths of the red, blue and green colors are overlapped (3) A ultraviolet LED is used to excite three or more phosphors for generating three colors of red, blue and green. This method also causes serious crosstalk. (4) Three separate red, blue and green LEDs are used to generate white light. The white light made by this method can achieve NTSC 105% or more, which is 1.5 times higher than the conventional CCFL. However, due to the different illumination efficiencies of different colors LEDs, different numbers of the red, blue and green LEDs are required for practical application. Generally speaking, the efficiency of green LED is

poorer, and thus more green LEDs are needed to balance with the light amount generated from other colored LEDs. However, the more LEDs the higher cost rises, and more space needs for accommodating the LEDs.

SUMMARY OF THE INVENTION

A liquid crystal display (LCD) of the present invention comprises a backlight module including an ultraviolet unit; a liquid crystal layer used for controlling light flux emitted from the backlight module; and a color filter layer comprising a plurality of pixels and a wavelength-converting material formed on one of the pixels, wherein the wavelength-converting material emits green light after being irradiated by the ultraviolet unit.

The backlight module further comprises a red-light unit and a blue-light unit, and preferably, at least one of the ultraviolet unit, the red-light unit and the blue-light unit is a light-emitting diode (LED).

The filter layer preferably has a reflection layer used for reflecting the specific light from the backlight module. Preferably, the color filter layer comprises a distributed bragg reflector (DBR) used for reflecting the light from the backlight module.

BRIEF DESCRIPTION OF THE DRAWINGS

The foregoing aspects and some attendant advantages of this invention will become more readily appreciated as the same becomes better understood by reference to the following detailed description, when taken in conjunction with the accompanying drawings, wherein:

FIG. 1 is a schematic diagram illustrating an embodiment of the present invention;

FIGS. 2a to 2e are schematic diagrams respectively illustrating a light-spreading device and an optically-conditioning surface in accordance with the embodiment of the present invention; and

FIGS. 3a and 3b are schematic diagrams illustrating the compositions of a semiconductor light-emitting element assembly in accordance with the embodiment of the present invention.

DETAILED DESCRIPTION OF THE PREFERRED EMBODIMENT

First Embodiment

FIG. 1 is a schematic diagram illustrating the structure of a LCD 10 of the present invention. Some components of the LCD 10 are omitted for clarity in FIG. 1.

The LCD 10 comprises a backlight module 11 acting as a light source to the LCD 10. Since the LCD 10 shows the image displayed in the visible wavelength range to a user, the backlight module 11 generally has to a light source in the visible wavelength range. The backlight module 11 generally has to provide white light, and the white light is preferably generated by the three primary colored light emitted from red, blue and green LEDs.

To increase the illumination efficiency of green light, the backlight module 11 of the present invention uses an ultraviolet emitter, such as an ultraviolet unit 1101, preferably, an ultraviolet LED, and a wavelength-converting material 1402 (labeled as P) which can absorb ultraviolet light to generate green light. The wavelength of the ultraviolet light herein is between 10 nm-420 nm, and preferably between 200 nm-420 nm. White light can be formed by mixing red light emitted

from a red-light unit **1102**, blue light emitted from a blue-light unit **1103**, and green light emitted from the wavelength-converting material **1402** radiated by the ultraviolet unit **1101**. The red-light unit **1102** and the blue-light unit **1103** includes by not limited to LEDs, florescent lamps, incandescent lamps and halogen lamps.

The wavelength-converting material **1402** is such as a phosphor able to being excited by the ultraviolet light emitted from the ultraviolet unit **1101** to generate green light. If the wavelength of the ultraviolet light from the ultraviolet unit **1101** ranges between 200 nm and 420 nm, preferably between 360 nm and 400 nm, the wavelength-converting material **1402** can use an alkaline earth metal silicate phosphor, and preferably an europium(Eu) activated alkaline earth metal silicate phosphor. The composition of the europium(Eu) activated alkaline earth metal silicate phosphor is $(\text{SrBaMg})_2\text{SiO}_4:\text{Eu}$. The FWHM (Full Width Half Maximum) of the light generated by such a phosphor is smaller than 35 nm and that of green light emitted by InGaN LEDs. The europium (Eu) activated alkaline earth metal silicate phosphor is available from the commercial products fabricated by Intematix Corporation, CA., USA, such as G400™/G380™/G360™ series.

Other phosphors that can be excited by UV light and emits green light is such as $(\text{Ba}_{1-x-y-z}\text{Ca}_x\text{Sr}_y\text{Eu}_z)_2(\text{Mg}_{1-w}\text{Zn}_w)\text{Si}_2\text{O}_7$, wherein $x+y+z=1$, $0.05 > z > 0$ and $w > 0.05$; $\text{Ca}_8\text{Mg}(\text{SiO}_4)_4\text{Cl}_2:\text{Eu}, \text{Mn}$; $\text{Ba}_2\text{SiO}_4:\text{Eu}$; $\text{Ba}_2\text{MgSi}_2\text{O}_7:\text{Eu}$; $\text{BaAl}_2\text{O}_4:\text{Eu}$; $\text{SrAl}_2\text{O}_4:\text{Eu}$; and $\text{BaMg}_2\text{Al}_6\text{O}_{27}:\text{Eu}$, etc., wherein the excited wavelength thereof is 330 nm-420 nm.

The numbers of the ultraviolet unit **1101**, the red-light unit **1102** and the blue-light unit **1103** depends on the factors including but not limited to the size of the LCD **10**, the brightness required by the LCD **10**, the lighting intensity of each of the units **1101**, **1102** and **1103**, and the optical design inside the backlight module **11**. The red, blue, and green (violet) LEDs can be arranged in a sequence including red-blue-green (violet), red-green (violet)-blue, blue-green (violet)-red, blue-red-green (violet), green (violet)-red-blue, green (violet)-blue-red, red-blue-green (violet)-red and red-green (violet)-blue-red.

In the present embodiment, since the ultraviolet light is invisible to human eyes, the mixture light **12** emitted from the backlight module **11** merely shows the light formed by mixing the red light with the blue light, i.e. the light in purple-red series.

A liquid crystal layer **13** comprises a liquid crystal material and a thin film transistor (TFT) layer. When a bias is applied to the TFT layer, the liquid crystal molecules will be tilted or rotated and accordingly the light flux of the mixture light **12** passing through the liquid crystal layer changed.

The mixture light **12** passes through the liquid crystal layer **13** and reaches a color filter layer **14**. The color filter layer **14** generally is formed on a glass substrate and comprises a plurality of pixels **1401** (labeled as R, P, B in FIG. 1). A pixel set is usually formed by at least three single color pixels for separating red, blue, and green light from the mixture light **12**.

In the present embodiment, the wavelength-converting material **1402** is disposed inside one pixel (hereinafter is called a green pixel P) in one pixel set. The wavelength-converting material **1402** is excited by the ultraviolet light emitted from the ultraviolet unit **1101** and generates green light (G). The other two pixels in one pixel set are a red pixel (R) and a blue pixel (B). The red and blue pixels may be formed by organic material. The red pixel (R) permits only the red light of the mixture light **12** passing, while the blue pixel (B) permits only the blue light of the mixture light **12**

passing. Consequently, the red pixel (R) displays red color, and the blue pixel (B) displays blue color.

Besides organic materials, the red pixel (R) and the blue pixel (B) also can be formed from the phosphors that can be excited by UV light to emit red light and blue light. The phosphors that can be excited by UV light to emit red light are such as $\text{Y}_2\text{O}_3\text{S}:\text{Eu}, \text{Bi}$; $\text{Y}_2\text{O}_3\text{S}:\text{Eu}, \text{Bi}$; and $3.5\text{MgO}.0.5\text{MgF}_2.\text{GeO}_2:\text{Mn}^{++}$, wherein the excited wavelength thereof is 330 nm-420 nm. The phosphors that can be excited by UV light to emit blue light are such as $\text{BaMg}_2\text{Al}_{16}\text{O}_{27}:\text{Eu}; (\text{SaBaCa})_5(\text{PO}_4)_3\text{Cl}:\text{Eu}$; and $\text{Sr}_4\text{Al}_{14}\text{O}_{25}:\text{Eu}$, wherein the excited wavelength thereof is 220 nm-330 nm.

Each of the pixels permits only a portion of white light passing, in other hand, the amount of light passing exiting the pixels is less than that entering the pixels due to the other portion of light being absorbed by the pixels, and accordingly light-output efficiency decreases. In order to raise the light-output efficiency, a DBR **1404** is formed in front of the filtering layer **1401** for reflecting the light in a selected wavelength. For example, in front of the red pixel (R), a DBR layer that can reflect blue light or ultraviolet light is formed for preventing the blue light or the ultraviolet light from being absorbed by the red pixel (R) and reflecting the blue light or the ultraviolet light so as to enter the blue pixel (B) or the green pixel (P). As to the other pixels, the corresponding DBRs may be used. Besides, since ultraviolet light is reflected by the DBR **1404**, the ultraviolet light can be prevented from emitting the LCD **10**.

Further, the LCD **10** may also comprise other optical films, such as a prism sheet, a diffuser and a polarizer, etc., wherein the prism sheet and the diffuser is generally disposed in the backlight module **11** for unifying the light emitted from the light-emitting units **1101-1103** so as to generate the desired mixture light **12**. The polarizer is generally used with the liquid crystal layer **13**, so that the mixture light **12** is polarized before entering the liquid crystal **13**.

Although the method of using ultraviolet light to excite the wavelength-converting material **1402** for generating green light can increase the green light output efficiency, yet some components inside the LCD **10**, particularly the plastic components such as the prism sheet, the diffuser and the polarizer, etc., are easily deteriorated due to ultraviolet irradiation. Hence those optical films or plastic components are preferably made of ultraviolet resistant material.

Other technical references related to the present invention, such as US2005/0001537A1, US2004/0061810A1, U.S. Pat. No. 6,686,691, U.S. Pat. No. 6,791,636, U.S. 6,844,903, U.S. Pat. No. 6,809,781, U.S. Pat. No. 6,252,254, U.S. Pat. No. 6,255,670, U.S. Pat. No. 6,278,135, U.S. Pat. No. 6,294,800, EP1138747, WO0189000 and WO0189001, are listed herein for reference.

Second Embodiment

The backlight module disclosed in the present embodiment comprises a light-spreading device **15** and/or an optically-conditioning surface **16** having a wavelike array for guiding, mixing and/or spreading the light generated from each of the light-emitting units **1101-1103** towards the liquid crystal layer **13**, such as shown in FIG. 2a.

Such as shown in FIG. 2b, the light-spreading device **15** has a wing-shaped protrusion part **1501**, a recess **1502** and a light-entering surface **1503**. The light-spreading device **15** is formed in a longitudinal direction **1504**. The recess **1502** is located away from the light-entering surface **1503**, and preferably is located on the side opposite to the light-entering

surface **1503**. A first wavelike array **1601** is formed on the light-conditioning surface **16** for diffusing and/or mixing the light emitted from the ultraviolet unit **1101**, the red-light unit **1102** and/or the blue unit **1103**, thereby preventing the back-light module **11** from generating light spots or showing unmixed colored light. A portion of the light passing through the light-entering surface **1503** of the light-spreading device **15** is total-internal-reflected on the recess **1502** to both sides thereof, i.e. to the wing-shaped protrusion part **1501**, and another portion of the light passing through the recess **1502** may be refracted in compliance with the Snell's law due to the difference of the refractive indexes between the light-spreading device **15** and the ambient optical medium. Since a portion of the light is total-internal-reflected in the recess **1502** and directed to the wing-shaped protrusion part **1501**, the light flux emitting from the recess **1502** is reduced. Preferably, the shape of the recess **1502** is similar to a V-shape or U-shape. The light inside wing-shaped protrusion part **1501** may be refracted, reflected or directly exit out of the light-spreading device **15**. For example, the light entering the light-spreading device **15** at a specific angle will be gradually mixed as uniform colored light after several times of total reflection inside the wing-shaped protrusion part **1501**. The light-entering surface **1503** is not limited to a planar surface, but also can be a concave shape or other shapes able to receive light.

A first wavelike array **1601** may be formed on the optically-conditioning surface **16**, and both of the optically-conditioning surface **16** and the first wavelike array **1601** may be formed on the light-entering surface **1503** of the light-entering surface **1503**. The first wavelike array **1601** is a wave-shaped surface. The wave-shaped surface has a wave propagation direction, i.e. the array direction or wavefront direction of the first wavelike array **1601**. The wave structures formed on the first wavelike array **1601** may be a plurality of micro-lenses. Light through the micro-lenses is blurred. The diameter of each micro-lens is about 50-60 μm . If the waves of the first wavelike array **1601** are constructed consecutively, a distance between two consecutive wave peaks or troughs is about between 100 μm and 120 μm .

The optically-conditioning surface **16** may optionally be formed inside the light-spreading device **15** by combining two light-pervious materials with different refractive indexes. The wavelike array is then formed on the interface of the two light-pervious materials, such as shown in FIG. **2c**. The hatched portion has a material different from the other portion's. The first wavelike array **1601** is not limited to being disposed on the light-entering surface **1503**, but also can be disposed on the wing-shaped protrusion part **1501** or/and the recess **1502**, such as shown in FIG. **2e**.

The material forming the light-spreading device **15** is such as acrylic resin, cyclo-olefin co-polymer (COC), polymethyl-methacrylate (PMMA), polycarbonate (PC), polyetherimide, fluorocarbon polymer, silicone, the combinations thereof, or other light-pervious material.

As shown in FIG. **2d**, the optically-conditioning surface **16** may also be formed on an optical film **17** having a first surface **1701** and a second surface **1702** opposite to the first surface **1701**. The optically-conditioning surface **16** is formed on one of the first surface **1701** and the second surface **1702**. If the optically-conditioning surface **16** is formed on the first surface **1701**, the first wavelike array **1601** is then formed on the first surface **1701**. The optical film **17** can be installed above the light-spreading device **15** or the area between the light-spreading device **15** and the light-emitting units **1101-1103**. Further, a second optically-conditioning surface **18** can be formed on the second surface **1702**, and a second wavelike

array **1801** is formed on the second optically-conditioning surface **18**. The array direction of the second wavelike array **1801** is different from that of the first wavelike array **1601**. In that case, a Moiré pattern can be formed by stacking the first wavelike array **1601** and the second wavelike array **1801** having different array directions. By properly adjusting the first wavelike array **1601** and the second wavelike array **1801**, the intensity of the light passing through the Moiré pattern can be re-distributed, thereby achieving the performance of scattering the light uniformly. The optical film **17** may be available from the product manufactured by S-Light Opt Electronics Inc., Taiwan.

The optically-conditioning surface **16** or **18** is not limited to being merely disposed on one of the light-spreading device **15** and the optical film **17**, but also can be formed on both of the light-spreading device **15** and the optical film **17**. The first wavelike array **1601** and the second wavelike array **1801** can have the same or different wave sizes, wave shapes and wave frequencies.

If the arrangement direction of the light-emitting units **1101, 1102** and/or **1103** is parallel to the array direction of the first wavelike array **1601**, i.e. to the wavefront direction thereof, a light pattern substantially parallel to the wavefront direction of the first wavelike array **1601** will be generated after the light passes through the first wavelike array **1601**. When the arrangement direction of the light sources **1101, 1102** and/or **1103** and the wavefront direction of the first wavelike array **1601** are formed in straight lines, the light will be distributed as straight lines; when the arrangement direction of the light sources **1101, 1102** and/or **1103** and the wavefront direction of the first wavelike array **1601** are formed in curved or radiating patterns, the light will be distributed as curved or radiating patterns. Theoretically, when the arrangement direction of the light sources **1101, 1102** and/or **1103** is parallel or about parallel to the wavefront direction of the first wavelike array **1601**, the light emitted from the light sources **1101, 1102** and/or **1103** is distributed into the light pattern extending along the wavefront direction.

The detailed techniques of the light-spreading device and the wavelike array have been described in Taiwan Application Serial Number 093129157 and Taiwan Application Serial Number 094114630, which are listed herein for reference.

Third Embodiment

In the present embodiment, the light-emitting units are semiconductor light-emitting elements, such as LEDs, and preferably LED dies. With the power increasing, the heat generated from LEDs also increases accordingly. For providing heat dissipation for the LEDs, the present invention installs the ultraviolet unit **1101**, the red-light unit **1102** and/or the blue-light unit **1103** on a composite substrate **1901**, such as shown FIG. **3a**. **19** indicates a semiconductor light-emitting element assembly, such as a LED package; **1901** indicates a composite substrate; **1902** indicates a connecting structure; **1903** indicates a circuit layout carrier; **1904** indicates an electrical contact; and **1905** indicates a conductive wire.

The circuit layout carrier **1903** is bonded to a composite substrate **1901** through a connecting structure **1902**. The ultraviolet unit **1101**, the red-light unit **1102** and/or the blue-light unit **1103** are fixed in a recess **1906**. Conductive wires **1905** or other electrically connecting means are used to connect the ultraviolet unit **1101**, the red-light unit **1102** and/or the blue-light unit **1103** to electrical contacts **1904** formed on the circuit layout carrier **1903**. The difference between the thermal expansion coefficient of the light-emitting units

1101-1103 and that of the composite substrate **1901** is approximately smaller than or equal to $10 \times 10^{-6}/^\circ\text{C}$., thus the thermal stress between the light-emitting units **1101-1103** and the composite substrate **1901** is reduced.

The thermal expansion coefficient of the LED die generally is between $1 \times 10^{-6}/^\circ\text{C}$. and $10 \times 10^{-6}/^\circ\text{C}$. For example, the thermal expansion coefficient of GaN is about $5.4 \times 10^{-6}/^\circ\text{C}$.; that of InP is about $4.6 \times 10^{-6}/^\circ\text{C}$.; that of GaP is about $5.3 \times 10^{-6}/^\circ\text{C}$. In order to decrease excessive thermal stress formed between the light-emitting units **1101-1103** and its contact material, a composite substrate **1901** is used as the supporting base of the semiconductor light-emitting element assembly **19**. Besides, the composite substrate **1901** is also used as a heat-dissipation media. The thermal expansion coefficient of the composite substrate **1901** is preferably smaller than or equal to $10 \times 10^{-6}/^\circ\text{C}$.

The composite material is usually formed from two or more materials, and these two or more materials do not form any other molecular or atomic structures. Generally speaking, the composite material can offer the benefits of the separate materials and has physical properties better than that of the original materials. The composite material usually has the benefits of lightweight, high strength, and good thermal properties etc. The composite material includes a metal matrix composite (MMC), a polymer matrix composite (PMC), and ceramic matrix composite (CMC). These composites are respectively formed by mixing carbon fibers or ceramic fibers with metals, polymers, and ceramics. The composite substrate **1901** preferably formed by the metal matrix composite with a thermal conductivity coefficient not smaller than 150 W/mK and a thermal expansion coefficient not greater than $10 \times 10^{-6}/^\circ\text{C}$., such as aluminum matrix composite (its thermal conductivity coefficient is about 100~640 W/mK; and its thermal expansion coefficient of the composite substrate is about $5 \sim 10 \times 10^{-6}/^\circ\text{C}$.). Nonetheless, a polymer matrix composite and ceramic matrix composite may also be used as the composite substrate **1901**.

The circuit layout carrier **1903** is, for example, a printed circuit board, a flexible printed circuit, a semiconductor substrate such as a Si substrate or a ceramic substrate, etc. The semiconductor substrate used as the circuit layer carrier **1903** can use various semiconductor processes such as etching, sputtering etc. to form the desired circuits thereon, and also can be integrated with the process for forming the semiconductor light-emitting diode. The semiconductor substrate such as the Si substrate has acceptable heat transfer properties (its thermal conductivity coefficient and thermal expansion coefficient are about 150 W/mK and $4 \times 10^{-6}/^\circ\text{C}$. respectively). Since the thermal conductivity coefficients and thermal expansion coefficients of a metal matrix composite substrate are close to those of a Si substrate, the thermal stress between the two kinds of materials can be effectively reduced and the conductive efficiency can be further improved. Nonetheless, the printed circuit board or the flexible printed circuit may also be used.

The circuit layout carrier **1903** is bonded to the composite substrate **1901** through the connecting structure **1902**. The connecting structure **1902** is made of adhesive material, preferably a flexible adhesive layer. The flexible adhesive layer preferably preserves adhesion at a room temperature or a medium low temperature. The material forming the flexible adhesive layer includes but not limited to benzocyclobutene (BCB), epoxy, polyimide, SOG (Spin On Glass), silicone, solder, equivalents thereof and combinations thereof. Those flexible adhesive materials can be cured at a relatively low temperature (commonly smaller than 300°C .), thereby reducing the thermal stress between the composite substrate

1901 and the light-emitting units **1101-1103** and/or between the composite substrate **1901** and the circuit layout carrier **1903** at high temperature, also lessening the damage to the light-emitting units **1101-1103** at high temperature.

As shown in FIG. 3b, the connecting structure **1902** is composed of a flexible adhesive layer **2001**, and a reaction layer **2002** and/or a reaction layer **2003**. The flexible adhesive layer **2001** can be formed by the material described above. The reaction layers **2002** and **2003** are formed respectively between the flexible adhesive layer **2001** and the circuit layout carrier **1903**; and/or between the flexible adhesive layer **2001** and the composite substrate **1901**, for enhancing the adhesion between the flexible adhesive layer **2001** and the circuit layout carrier **1903** and/or the composite substrate **1901**. The material forming the reaction layers **2002** and **2003** includes but not limited to silicon nitride (SiN_x), epoxy, titanium (Ti), chromium (Cr), or combinations thereof. The reaction layer **2002** and/or the reaction layer **2003** can be formed on the circuit layout carrier **1903** and/or the composite substrate **1901** by the method of physical vapor deposition (PVD) or chemical vapor deposition (CVD). The flexible adhesive layer **2001** may be formed on one side of the circuit layout carrier **1903** and/or one side of the composite substrate **1901**. The circuit layout carrier **1903** is bonded to the composite substrate **1901** at certain pressure and temperature, such as 328 g/cm^2 - 658 g/cm^2 and 150°C .- 600°C ., and preferably 505 g/cm^2 and 200°C .- 300°C .

If the surface of The composite substrate **1901** is a rough surface, a planarizing layer **21** is formed on the surface of the composite substrate **1901** for flattening the rough surface of the composite substrate **1901** and improving the adhesion between the connecting structure **1902** and the composite substrate **1901**. The material forming the planarizing layer **21** is such as nickel (Ni) or any other materials adhesible to the connecting structure **1902**.

In the present embodiment, a wavelength-converting material **1402** covers the area above the light-emitting units **1101**, **1102** and/or **1103**. Furthermore, a light-pervious member, such as a lens, is capped the wavelength-converting material **1402** for securing and/or protecting the wavelength-converting material **1402**.

The wavelength-converting material **1402** may be mixed with light-pervious material or other adhesive material and then is formed on the light-emitting units **1101**, **1102** and/or **1103**. Alternatively, the wavelength-converting material **1402** may also be formed over the area above the light-emitting units **1101**, **1102** and/or **1103** by sedimentation without the mixture of the light-pervious material or any adhesive material.

A reflection layer **22** may be optionally formed inside the recess **1906** for reflecting and guiding the light emitted by the light-emitting units **1101-1103**. The reflection layer **22** is formed by a light-reflection material, such as gold, silver, aluminum, and tin etc. The reaction layer **22** is formed on the partial or whole interior surface of the recess **1906** by using various known film deposition methods. Further, if the reflection layer **22** is electrical conductive, for keeping the insulation between the light-emitting units **1101-1103** and the reflection layer **22**, the reflection layer **22** is preferably not formed on the area above the light-emitting units **1101-1103** covering the composite substrate **1901**. In addition, for enabling the reflection layer **22** to achieve better reflection efficiency, the recess **1906** is formed in a tapered shape, i.e. the inner wall of the recess **1906** has a slope that forms a funnel-shaped volume inside the recess **1906**.

The detailed techniques of the light-spreading device and the wavelike array have been described in Taiwan Application Serial Number 094103538, which is listed herein for reference.

As is understood by a person skilled in the art, the foregoing preferred embodiments of the present invention are illustrated of the present invention rather than limiting of the present invention. It is intended to cover various modifications and similar arrangements included within the spirit and scope of the appended claims, the scope of which should be accorded the broadest interpretation so as to encompass all such modifications and similar structures.

What is claimed is:

1. A liquid crystal display, comprising:
 - a backlight module comprising an ultraviolet unit, a red-light unit and a blue-light unit;
 - a liquid crystal layer for controlling light flux emitted from the backlight module; and
 - a color filter layer comprising a plurality of pixels and a wavelength-converting material formed on one of the pixels, wherein the wavelength-converting material emits green light after being irradiated by the ultraviolet unit.
2. The liquid crystal display of claim 1, wherein at least one of the ultraviolet unit, the red-light unit and the blue-light unit is a light-emitting diode.
3. The liquid crystal display of claim 1, wherein the pixels comprise a red pixel for passing through by red light, and a blue light pixel for passing through by blue light.
4. The liquid crystal display of claim 1, wherein the wavelength of the light emitted from the ultraviolet unit is between 200 nm and 420 nm.
5. The liquid crystal display of claim 1, wherein the color filter layer reflects the light from the backlight module.
6. The liquid crystal display of claim 1, wherein the color filter layer comprises a distributed bragg reflector (DBR) for reflecting the light from the backlight module.
7. The liquid crystal display of claim 1, wherein the liquid crystal layer comprises a thin film transistor (TFT) layer.

8. The liquid crystal display of claim 1, further comprising a plurality of optical films.

9. The liquid crystal display of claim 8, wherein one of the optical films is insensitive to ultraviolet.

10. The liquid crystal display of claim 8, wherein one of the optical films is selected from a group consisting of a prism sheet, a diffuser and a polarizer.

11. The liquid crystal display of claim 1, wherein the backlight module further comprises:

a light-spreading device for directing the light inside the backlight module towards the liquid crystal layer.

12. The liquid crystal display of claim 1, wherein the backlight module further comprises:

an optically-conditioning surface having a wavelike array.

13. The liquid crystal display of claim 1, wherein the wavelength-converting material comprises alkaline earth metal silicate.

14. The liquid crystal display of claim 1, wherein the wavelength-converting material comprises europium(Eu)-activated alkaline earth metal silicate.

15. The liquid crystal display of claim 1, wherein the wavelength-converting material is selected from a group consisting of $(\text{SrBaMg})_2\text{SiO}_4:\text{Eu}$; $(\text{Ba}_{1-x-y-z}\text{Ca}_x\text{Sr}_y\text{Eu}_{z/2})(\text{Mg}_{1-w}\text{Zn}_w)\text{Si}_2\text{O}_7$, wherein $x+y+z=1$, $0.05 > z > 0$ and $w < 0.05$; $\text{Ca}_8\text{Mg}(\text{SiO}_4)_4\text{Cl}:\text{Eu}, \text{Mn}$; $\text{Ba}_2\text{SiO}_4:\text{Eu}$; $\text{Ba}_2\text{MgSi}_2\text{O}_7:\text{Eu}$; $\text{BaAl}_2\text{O}_4:\text{Eu}$; $\text{SrAl}_2\text{O}_4:\text{Eu}$; and $\text{BaMg}_2\text{Al}_{16}\text{O}_{27}:\text{Eu}$.

16. The liquid crystal display of claim 1, wherein the red-light unit and the blue-light unit comprise phosphors.

17. The liquid crystal display of claim 1, wherein the red-light unit comprises a material selected from a group consisting of $\text{Y}_2\text{O}_2\text{S}:\text{Eu}, \text{Bi}$; $\text{Y}_2\text{O}_3\text{S}:\text{Eu}, \text{Bi}$; and $3.5\text{MgO}_{0.5}\text{MgF}_2\cdot\text{GeO}_2:\text{Mn}^{+4}$.

18. The liquid crystal display of claim 1, wherein the blue-light unit comprises a material selected from a group consisting of $\text{BaMg}_2\text{Al}_{16}\text{O}_{27}:\text{Eu}$; $(\text{SaBaCa})_5(\text{PO}_4)_3\text{Cl}:\text{Eu}$; and $\text{Sr}_4\text{Al}_{14}\text{O}_{25}:\text{Eu}$.

* * * * *

专利名称(译)	液晶显示器		
公开(公告)号	US7724321	公开(公告)日	2010-05-25
申请号	US11/233039	申请日	2005-09-23
[标]申请(专利权)人(译)	HSIEH MIN HSUN 王建元		
申请(专利权)人(译)	HSIEH 闵勋 王建元		
当前申请(专利权)人(译)	晶元光电股份有限公司		
[标]发明人	HSIEH MIN HSUN WANG CHIEN YUAN		
发明人	HSIEH, MIN-HSUN WANG, CHIEN-YUAN		
IPC分类号	G02F1/1335 G02F1/13357 G02F1/1368		
CPC分类号	G02B27/0927 G02B27/095 G02F1/133514 G02F1/133617 G02B19/0028 G02B19/0066 G02B19/0071 G02B19/0095 H01L33/486 H01L2224/48091 H01L2924/01322 H01L2924/00014 H01L2924/00		
审查员(译)	NGUYEN, 龚便		
优先权	094121784 2005-06-29 TW 094103538 2005-02-04 TW 094128643 2005-08-22 TW 094114630 2005-05-06 TW 093129157 2004-09-24 TW		
其他公开文献	US20060065900A1		
外部链接	Espacenet USPTO		

摘要(译)

本发明公开了一种具有背光模块，液晶层和彩色滤光层的液晶显示器。用于发射紫外线的紫外线单元设置在背光模块中。滤色器层由纯度的像素构成，并且至少一个纯度的像素填充有波长转换材料。波长转换材料可以将紫外线转换成绿光。

