



(19) **United States**

(12) **Patent Application Publication**
Kim et al.

(10) **Pub. No.: US 2008/0246906 A1**

(43) **Pub. Date: Oct. 9, 2008**

(54) **LIQUID CRYSTAL DISPLAY DEVICE AND METHOD OF FABRICATING THE SAME**

(76) Inventors: **Jin Wuk Kim**, Uiwang-si (KR);
Tae Joon Song, Suwon si (KR)

Correspondence Address:
MCKENNA LONG & ALDRIDGE LLP
Song K. Jung
1900 K Street, N.W.
Washington, DC 20006 (US)

(21) Appl. No.: **12/005,615**

(22) Filed: **Dec. 28, 2007**

(30) **Foreign Application Priority Data**

Apr. 9, 2007 (KR) 10-2007-0034743

Publication Classification

(51) **Int. Cl.**
G02F 1/1339 (2006.01)
G02F 1/1335 (2006.01)
H01L 21/02 (2006.01)
(52) **U.S. Cl.** **349/106; 438/30; 349/156**

(57) **ABSTRACT**

A liquid crystal display device and a method of fabricating the same is disclosed, to provide a liquid crystal display device to simplify the process and decrease the fabrication cost, the liquid crystal display device includes a first substrate having a color filter and a second substrate having a thin film transistor, wherein the first and second substrates face each other, a first passivation film formed on the thin film transistor, and a first column spacer formed integrally with the first passivation film.

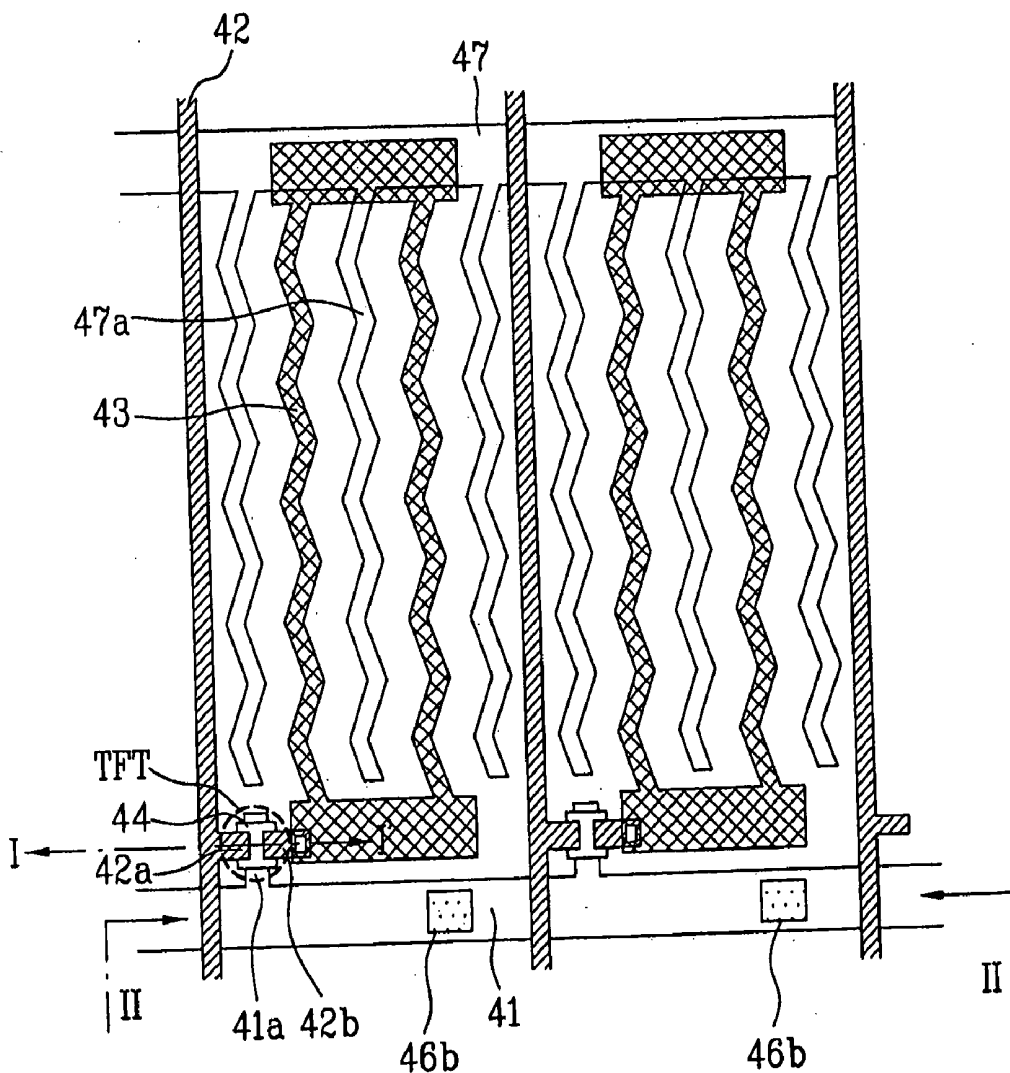

FIG. 1
Related Art

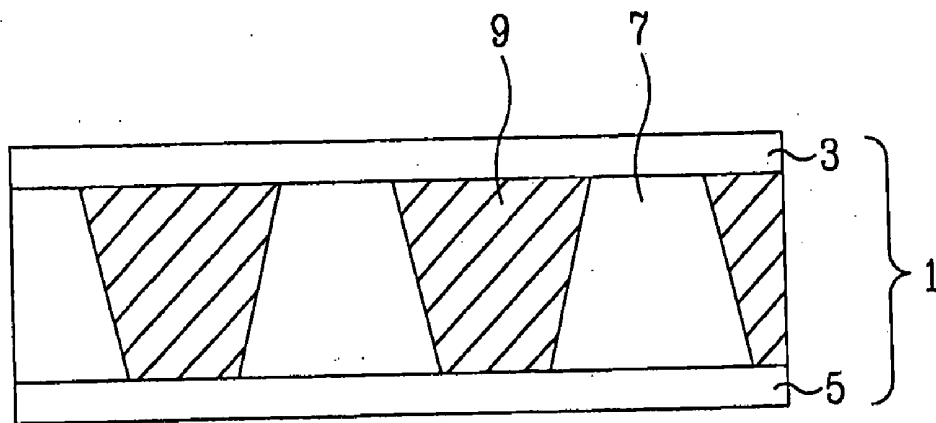

FIG. 2

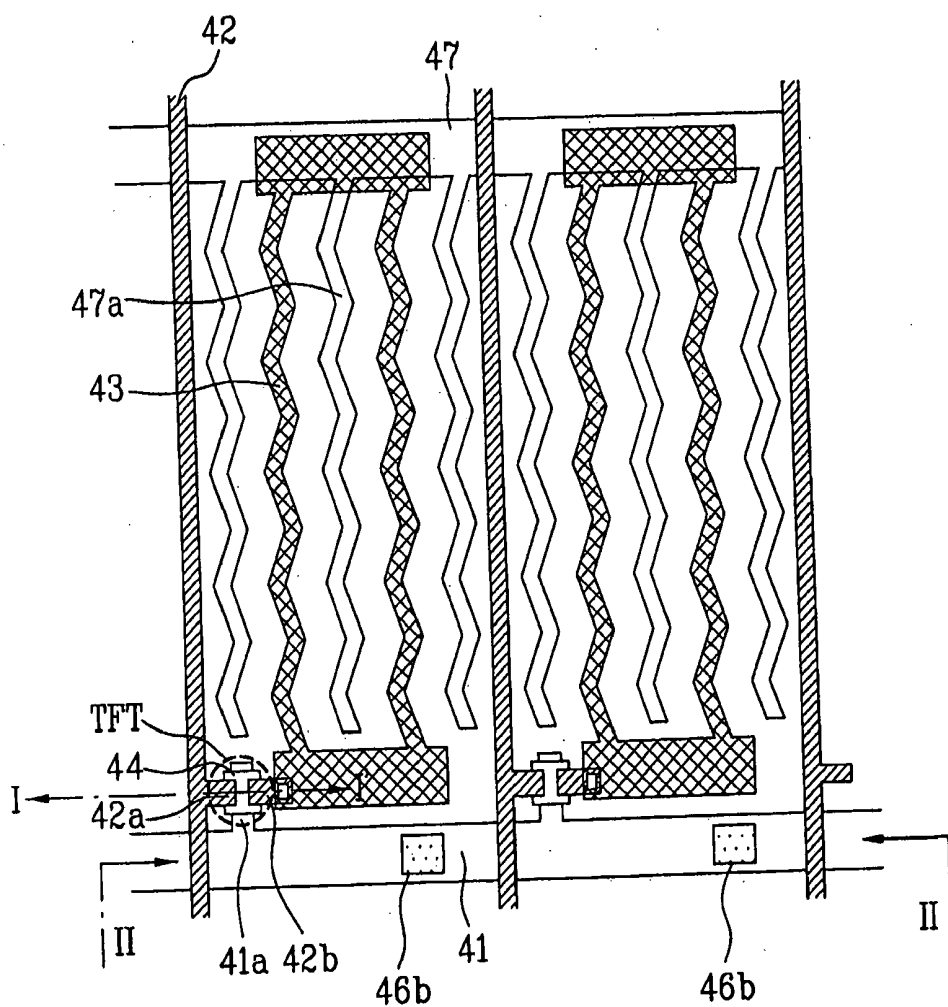

FIG. 3

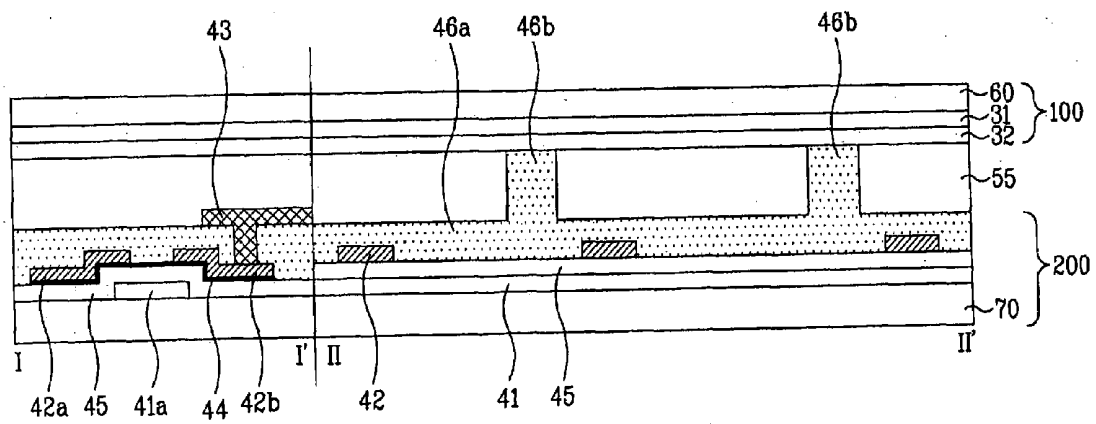

FIG. 4A

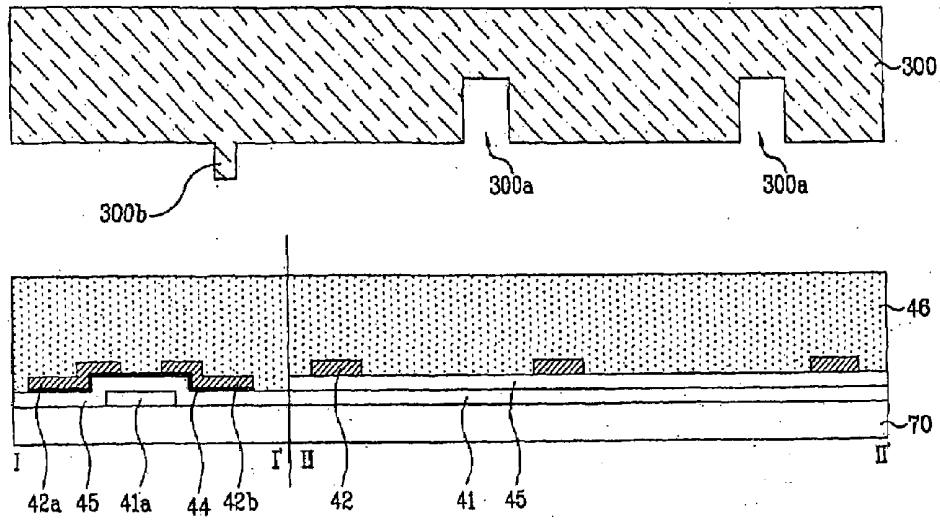

FIG. 4B

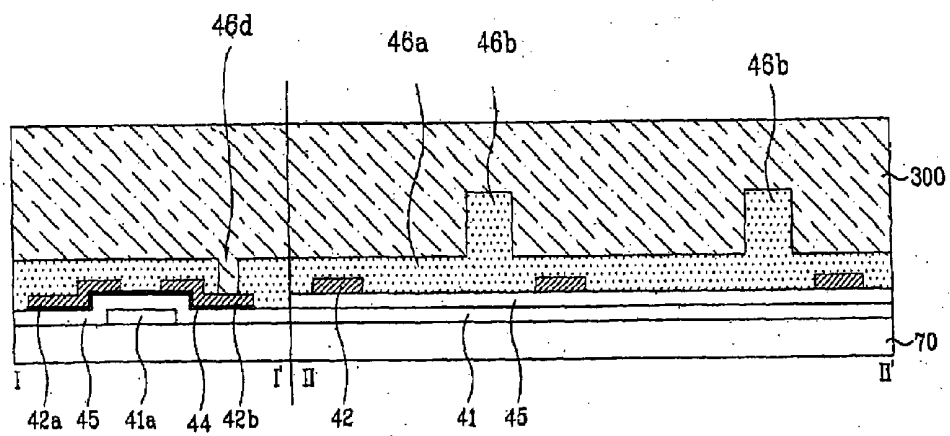

FIG. 4C

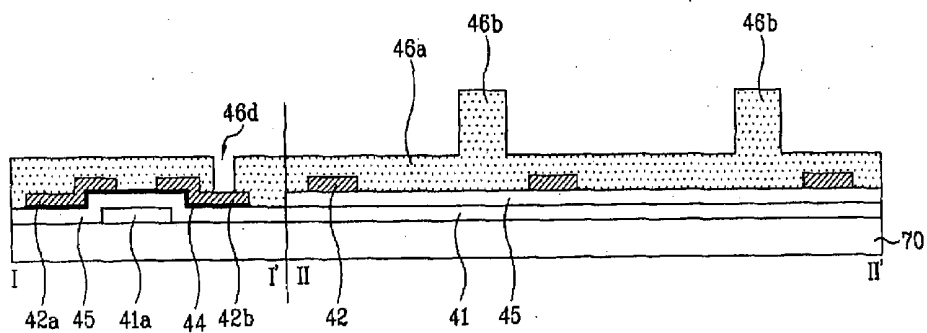

FIG. 4D

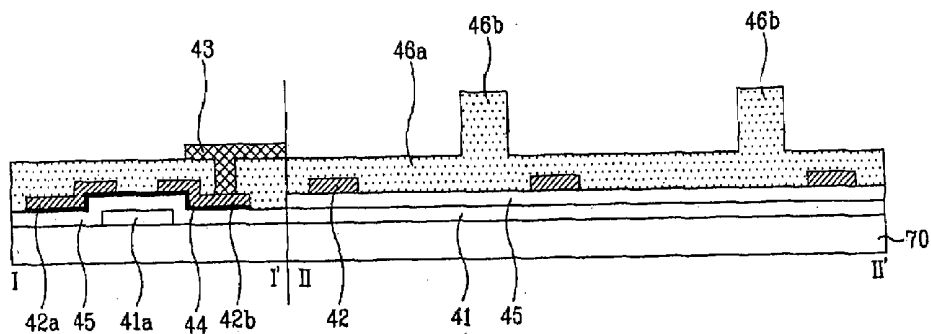

FIG. 5

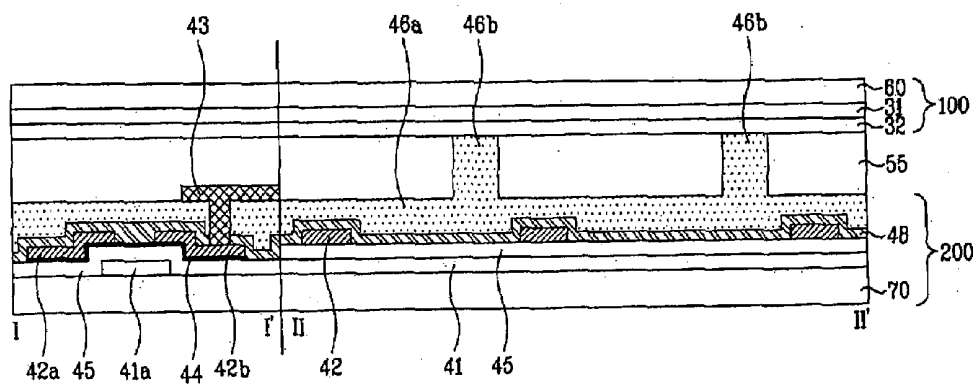

FIG. 6A

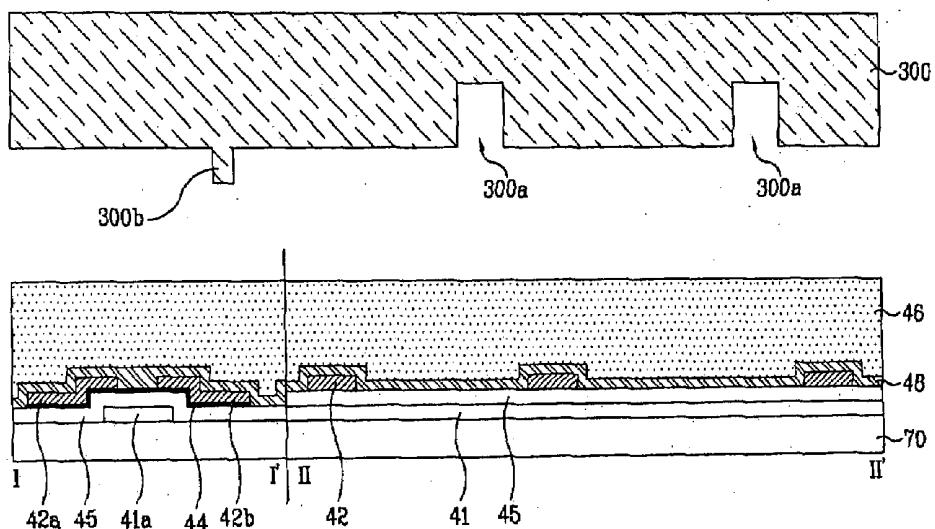

FIG. 6B

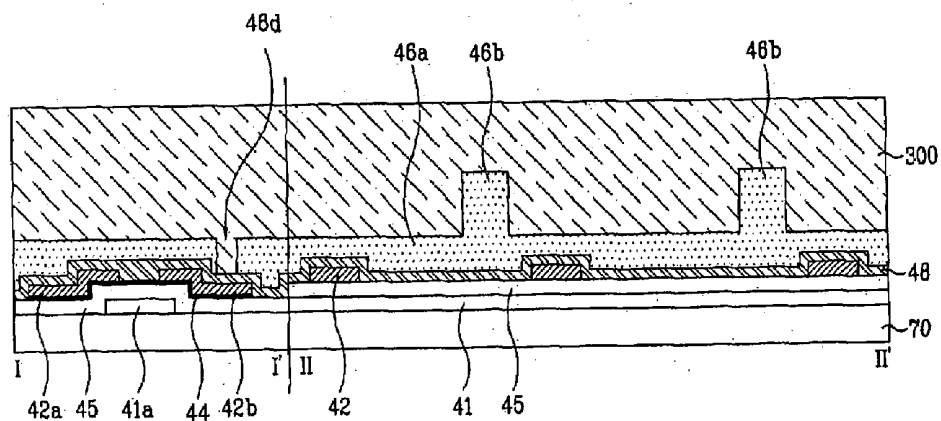

FIG. 7

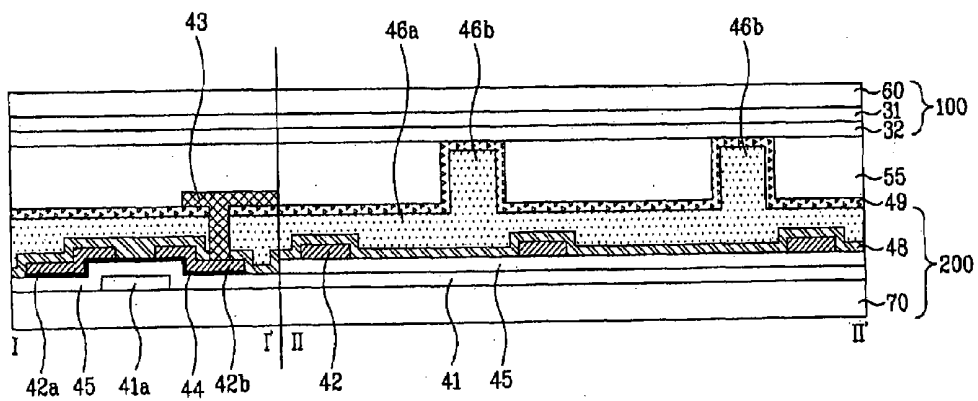

FIG. 8A

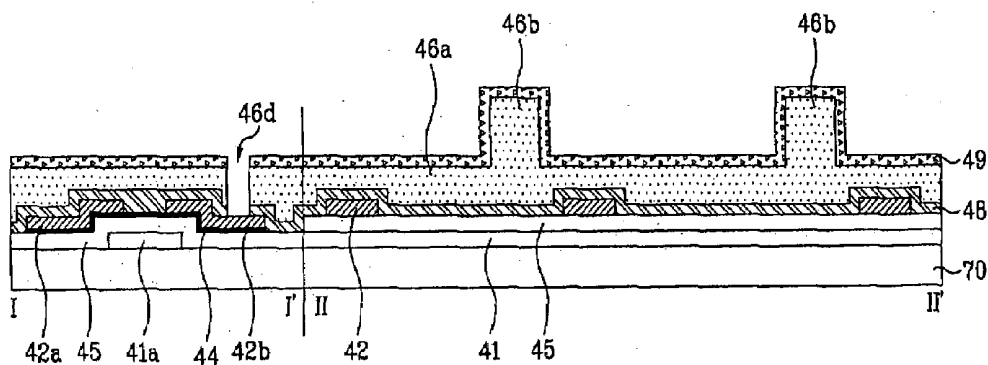

FIG. 8B

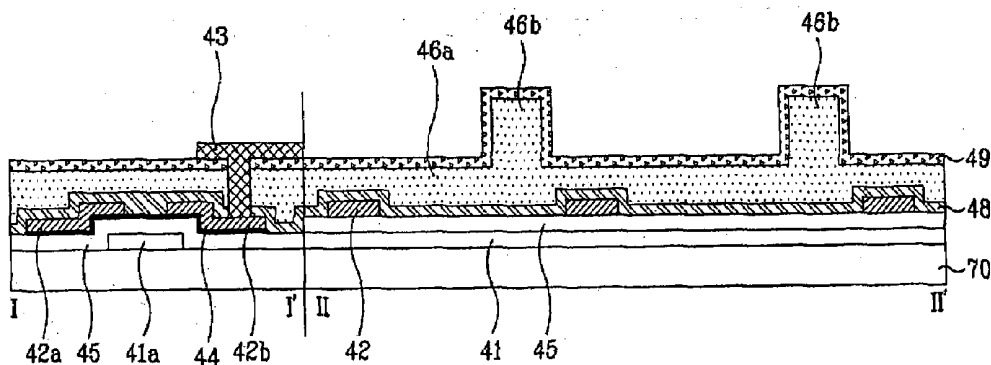

FIG. 9

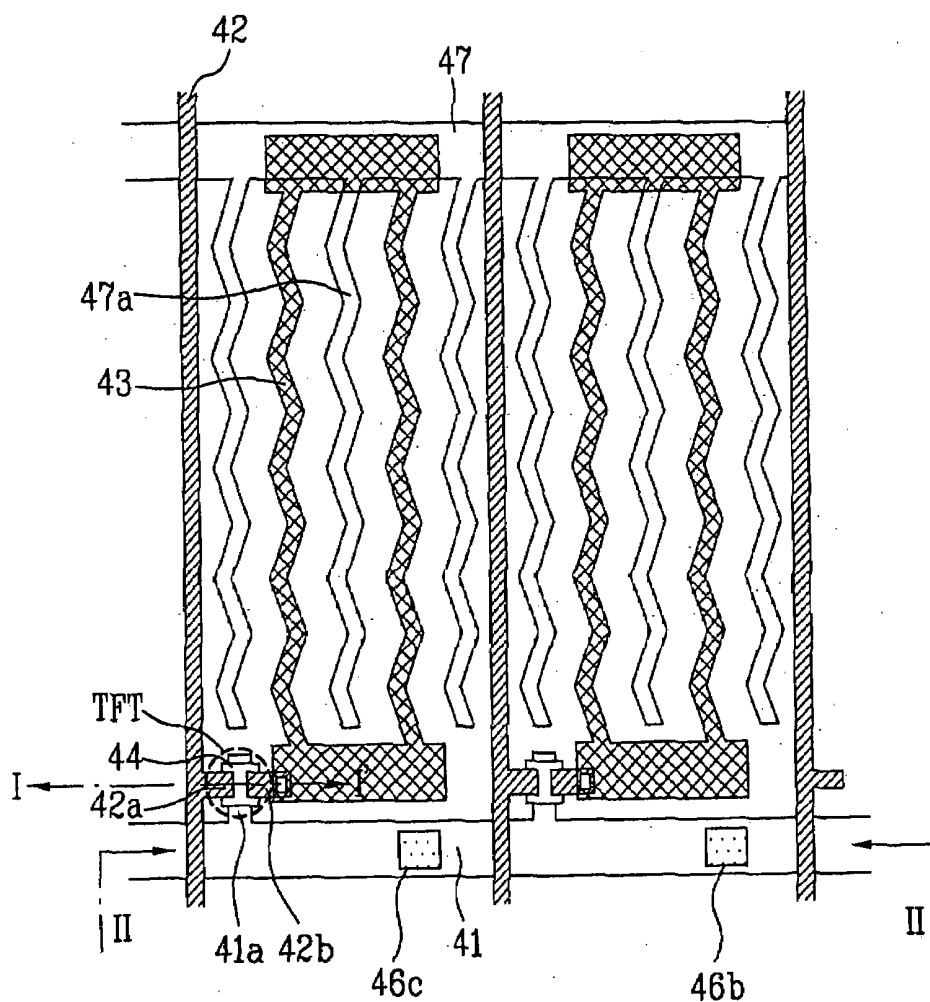

FIG. 10

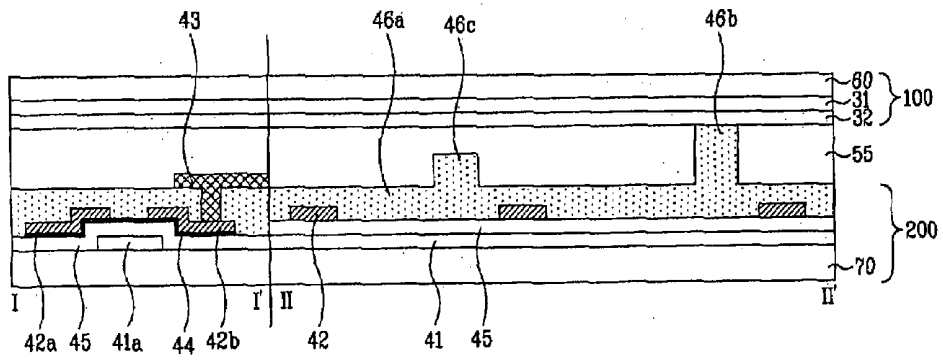

FIG. 11A

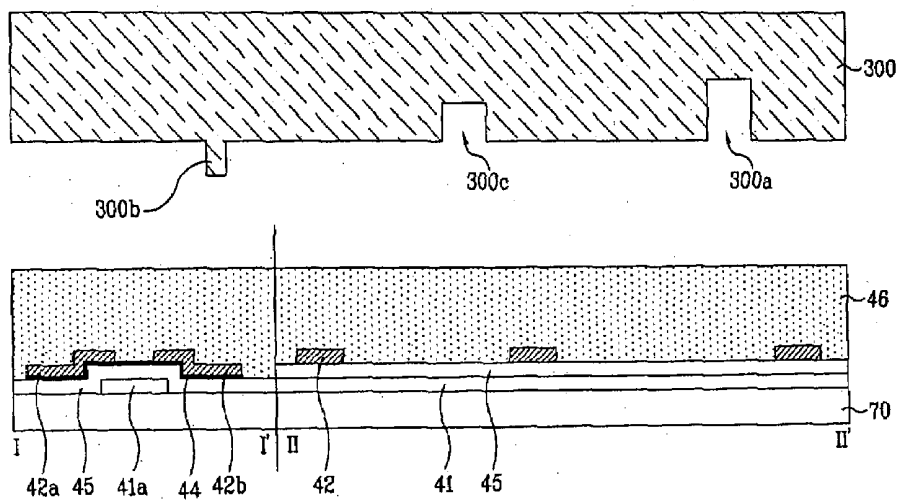

FIG. 11B

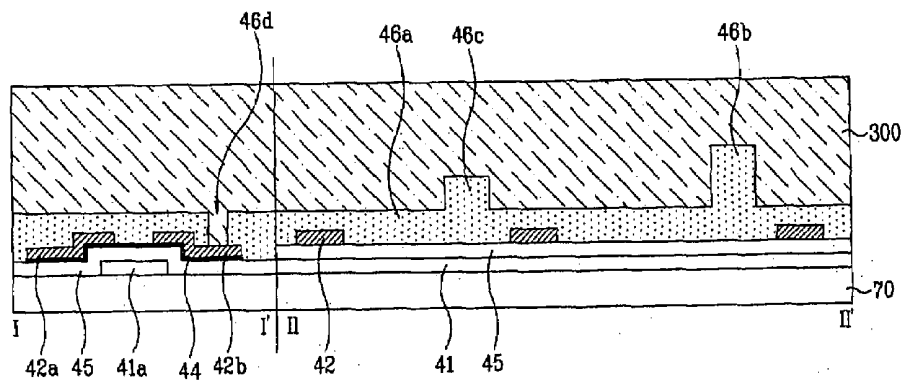

FIG. 11C

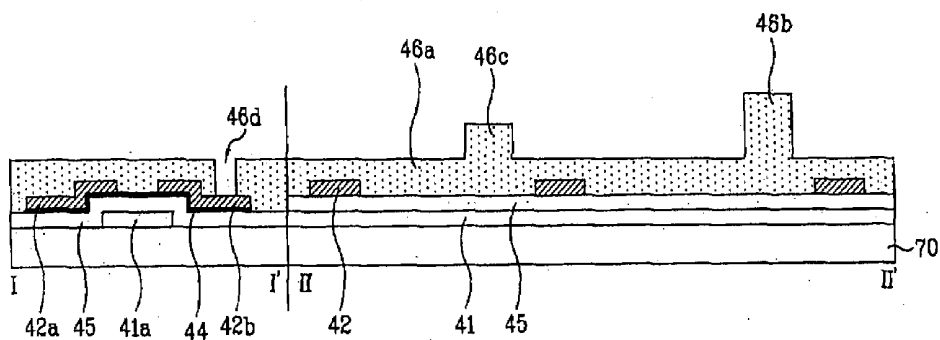

FIG. 11D

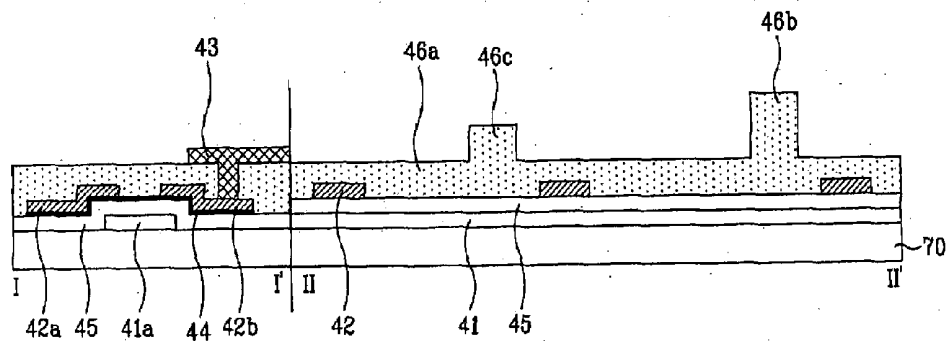

FIG. 12

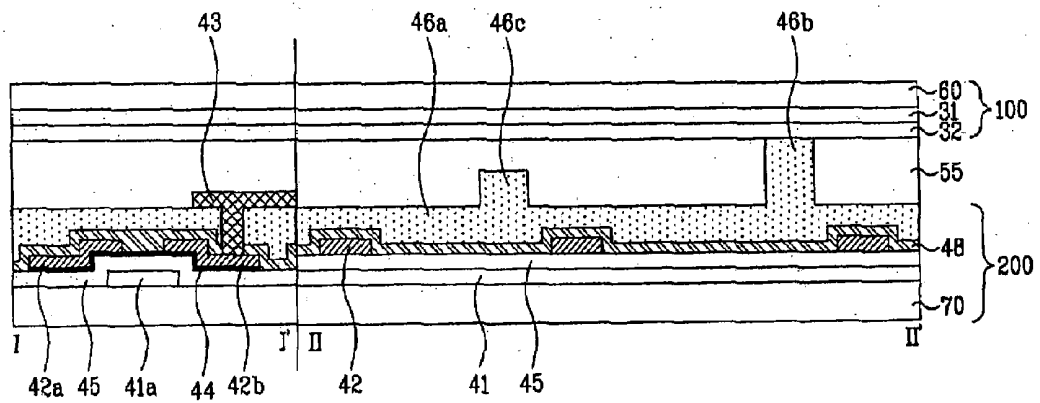

FIG. 13A

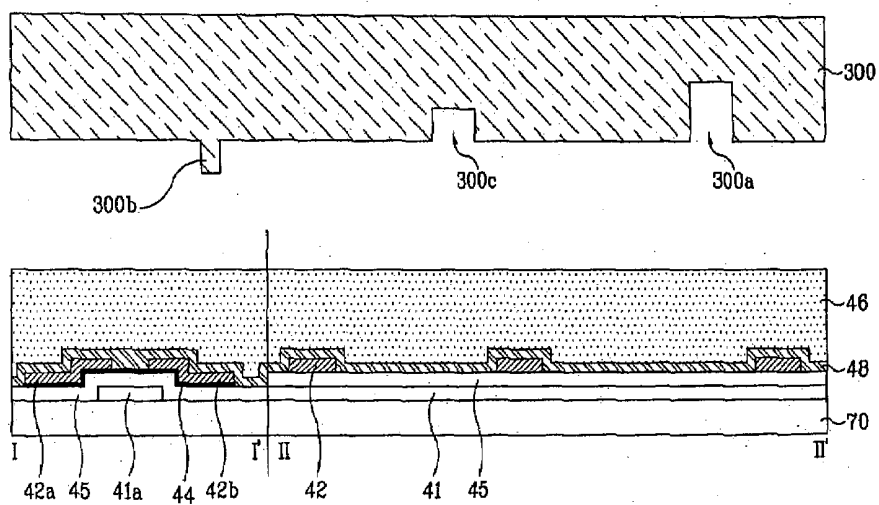

FIG. 13B

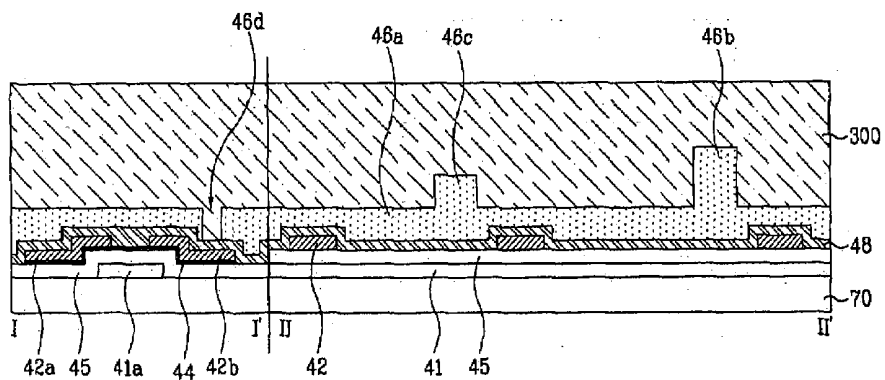

FIG. 13C

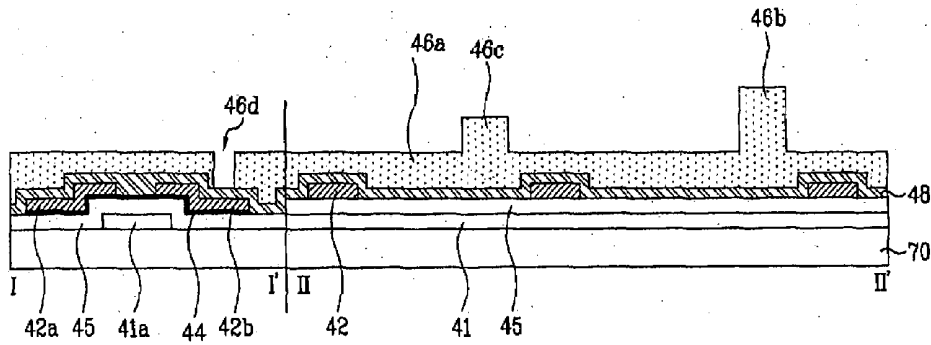

FIG. 13D

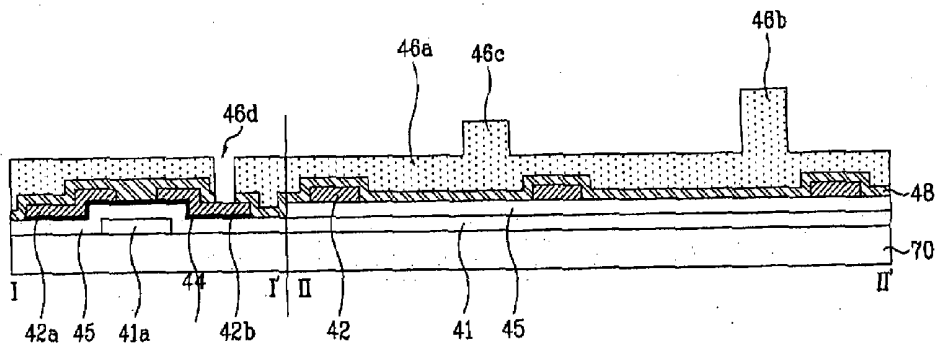

FIG. 13E

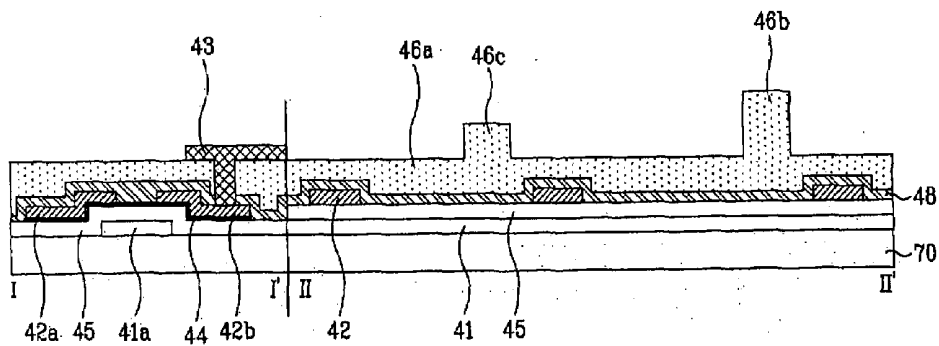

FIG. 14

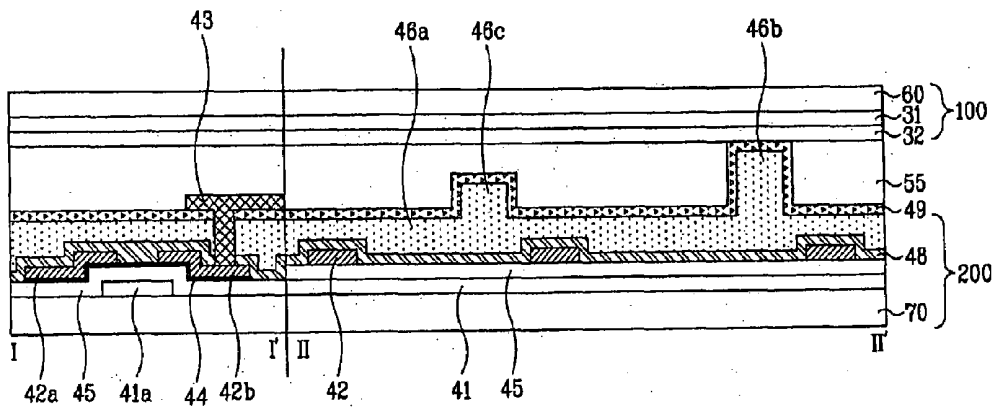

FIG. 15A

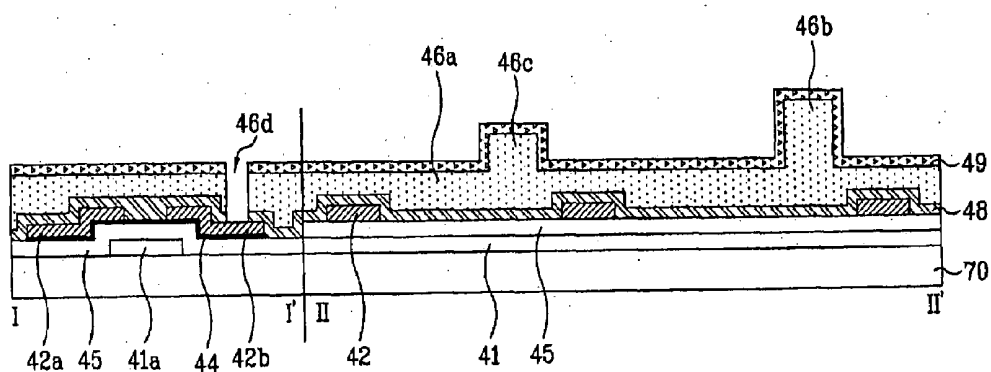
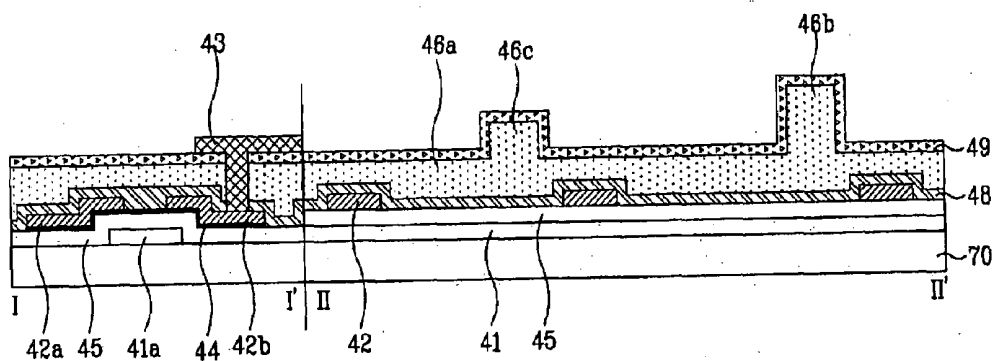

FIG. 15B



LIQUID CRYSTAL DISPLAY DEVICE AND METHOD OF FABRICATING THE SAME

[0001] This application claims the benefit of Korean Patent Application No. 2007-0034743 filed on Apr. 9, 2007, which is hereby incorporated by reference for all purposes as if fully set forth herein.

BACKGROUND OF THE INVENTION

[0002] 1. Field of the Invention

[0003] The present invention relates to display devices and more particularly to a liquid crystal display device and a method of fabricating the same.

[0004] 2. Discussion of the Related Art

[0005] Recently, various mobile-type electronic devices, such as mobile phones, PDAs, notebook computers, have become widely used, and there is increasing demand for a thin and light flat panel display device. Examples of flat panel display devices include liquid crystal display (LCD) devices, plasma display panels PDP, field emission displays FED, and vacuum fluorescent displays VFD. Among the various examples of flat panel display devices, the liquid crystal display (LCD) device has attracted great attention due to advantages such as its suitability for mass production, simple driving means, and high resolution and picture quality.

[0006] FIG. 1 is a cross section view illustrating a liquid crystal display device according to the related art. As shown in FIG. 1, the liquid crystal display device 1 according to the related art includes a lower substrate 5, an upper substrate 3, and a liquid crystal layer 7 formed between the lower substrate 5 and the upper substrate 3.

[0007] The lower substrate 5 corresponds to a thin film transistor array substrate, which includes a plurality of pixel regions, wherein a thin film transistor is formed in each of the pixel region.

[0008] The upper substrate 3 corresponds to a color filter substrate, which includes a color filter layer to realize colors.

[0009] Pixel electrodes and a common electrode are formed on the lower substrate 5 and the upper substrate 3, respectively. In addition, the lower and upper substrates 5 and 3 are coated with alignment films to align liquid crystal molecules included in the liquid crystal layer 7.

[0010] Spacers 9 are provided between the lower substrate 5 and the upper substrate 3, to maintain a cell gap therebetween. The liquid crystal layer 7 is formed between the lower substrate 5 and the upper substrate 3. Accordingly, as the liquid crystal molecules included in the liquid crystal layer 7 are driven by the thin film transistors formed on the lower substrate 5, an amount of light passing through the liquid crystal layer is controlled so that information is displayed.

[0011] The liquid crystal display device uses electro-optic effects resulting from anisotropy of the liquid crystal associated with the alignment of liquid crystal molecules. Accordingly, the display stability of a liquid crystal display device is largely affected by the control of the alignment of liquid crystal molecules.

[0012] The processes for forming the alignment film to align the liquid crystal molecules and for forming the spacers to maintain the cell gap with a seal pattern greatly affect the picture quality in the liquid crystal cell.

[0013] When the spacers are scattered by a related art method, the spacers may exist in the pixel region through which light is transmitted to display an image. The spacers in

the pixel region may disturb the alignment of liquid crystal, and may lower an aperture ratio of the liquid crystal cell. Accordingly, the density of spacers is controlled to be below a predetermined level. Additionally, it is desirable to uniformly distribute the spacers over an entire screen.

[0014] A high density of spacers is useful for maintaining the cell gap between the two substrates. Employing a high density of spacers may deteriorate the ability of the display to display black, lowering a contrast ratio of the display because the spacers cause dispersion of light and disorder of the alignment of liquid crystal in the area surrounding the spacer.

[0015] In order to overcome this problem, a method of providing column spacers has been proposed recently in which the spacers are directly patterned on the lower or upper substrate. The column spacers of the related art can be fabricated by depositing or coating organic polymer material on a substrate and carrying out photolithography to selectively remove portions of the deposited or coated organic polymer material.

[0016] Photolithography includes coating, exposure and development of photoresist, thereby requiring using an additional mask resulting in a more complex manufacturing process and in an increase in manufacturing costs.

SUMMARY OF THE INVENTION

[0017] Accordingly, the present invention is directed to a liquid crystal display device and a method of fabricating the same that substantially obviates one or more of the problems due to limitations and disadvantages of the related art.

[0018] An advantage of the present invention is to provide a liquid crystal display device to simplify the process and decrease the fabrication cost, and a method of fabricating the same.

[0019] Additional features and advantages of the invention will be set forth in the description which follows, and in part will be apparent from the description, or may be learned by practice of the invention. These and other advantages of the invention will be realized and attained by the structure particularly pointed out in the written description and claims hereof as well as the appended drawings.

[0020] To achieve and other advantages and in accordance with the purpose of the invention, as embodied and broadly described herein, a liquid crystal display device includes a first substrate having a color filter and a second substrate having a thin film transistor, wherein the first and second substrates face each other, a first passivation film formed on the thin film transistor, and a first column spacer formed integrally with the first passivation film.

[0021] In another aspect of the present invention, a method of fabricating a liquid crystal display device includes preparing a first substrate having a color filter, forming a thin film transistor on a second substrate facing the first substrate, forming a pattern material layer on the second substrate including the thin film transistor, aligning a soft mold with the second substrate including the pattern material layer, forming a contact hole, a first passivation film and a first column spacer by contacting the soft mold with the pattern material layer, separating the soft mold from the pattern material layer, and forming a pixel electrode that connects to the thin film transistor via the contact hole.

[0022] In another aspect of the present invention a method of fabricating an array substrate for a liquid crystal display device includes forming a thin film transistor on a substrate, forming a pattern material layer on the substrate including the

thin film transistor, aligning a soft mold with the substrate including the pattern material layer, forming a contact hole, a first passivation film and a first column spacer by contacting the soft mold to the pattern material layer, separating the soft mold from the pattern material layer, and forming a pixel electrode that connects to the thin film transistor via the contact hole.

[0023] It is to be understood that both the foregoing general description and the following detailed description are exemplary and explanatory and are intended to provide further explanation of the invention as claimed.

BRIEF DESCRIPTION OF THE DRAWINGS

[0024] The accompanying drawings, which are included to provide a further understanding of the invention and are incorporated in and constitute a part of this specification, illustrate embodiments of the invention and together with the description serve to explain the principles of the invention.

[0025] In the drawings:

[0026] FIG. 1 is a cross section diagram illustrating a related art liquid crystal display device;

[0027] FIG. 2 is a plan diagram illustrating one liquid crystal display device according to the present invention;

[0028] FIG. 3 is a cross section diagram illustrating a liquid crystal display device according to the first embodiment of the present invention, along I-I' and II-II' of FIG. 2;

[0029] FIGS. 4A to 4D are cross section diagrams illustrating a method of fabricating a liquid crystal display device according to the first embodiment of the present invention;

[0030] FIG. 5 is a cross section diagram illustrating a liquid crystal display device according to the second embodiment of the present invention, along I-I' and II-II' of FIG. 2;

[0031] FIGS. 6A to 6E are cross section diagrams illustrating a method of fabricating a liquid crystal display device according to the second embodiment of the present invention;

[0032] FIG. 7 is a cross section diagram illustrating a liquid crystal display device according to the third embodiment of the present invention, along I-I' and II-II' of FIG. 2;

[0033] FIGS. 8A and 8B are cross section diagrams illustrating a method of fabricating a liquid crystal display device according to the third embodiment of the present invention;

[0034] FIG. 9 is a plan diagram illustrating another liquid crystal display device according to the present invention;

[0035] FIG. 10 is a cross section diagram illustrating a liquid crystal display device according to the fourth embodiment of the present invention, along I-I' and II-II' of FIG. 9;

[0036] FIGS. 11A to 11D are cross section diagrams illustrating a method of fabricating a liquid crystal display device according to the fourth embodiment of the present invention;

[0037] FIG. 12 is a cross section diagram illustrating a liquid crystal display device according to the fifth embodiment of the present invention, along I-I' and II-II' of FIG. 9;

[0038] FIGS. 13A to 13E are cross section diagrams illustrating a method of fabricating a liquid crystal display device according to the fifth embodiment of the present invention;

[0039] FIG. 14 is a cross section diagram illustrating a liquid crystal display device according to the sixth embodiment of the present invention, along I-I' and II-II' of FIG. 9; and

[0040] FIGS. 15A and 15B are cross section diagrams illustrating a method of fabricating a liquid crystal display device according to the sixth embodiment of the present invention.

DETAILED DESCRIPTION OF THE ILLUSTRATED EMBODIMENTS

[0041] Reference will now be made in detail to embodiments of the present invention, examples of which are illustrated in the accompanying drawings. Wherever possible, the same reference numbers will be used throughout the drawings to refer to the same or like parts.

[0042] Hereinafter, a liquid crystal display device according to the present invention and a method of fabricating the same will be explained with reference to the accompanying drawings.

[0043] FIG. 2 is a plan diagram illustrating a liquid crystal display device according to the present invention. FIG. 3 is a cross section diagram illustrating a liquid crystal display device according to the first embodiment of the present invention, along I-I' and II-II' of FIG. 2.

[0044] As shown in FIGS. 2 and 3, the liquid crystal display device according to the first embodiment of the present invention includes a color filter substrate 100, a thin film transistor (TFT) substrate 200, and a liquid crystal layer 55 formed by injecting liquid crystal into a space between the color filter substrate 100 and the TFT substrate 200.

[0045] The color filter substrate 100 includes a black matrix layer 31 and a R/G/B color filter layer 32 on a substrate 60, wherein the black matrix layer 31 prevents light from leaking through regions other than the pixel regions (e.g. regions of gate line, data line and thin film transistor), and the R/G/B color filter layer 32 provided in the pixel regions to realize colors for an image. In addition, an overcoat layer (not shown) is formed on an entire surface of the black matrix layer 31 and the R/G/B color filter layer 32.

[0046] The TFT substrate 200 is disposed opposite the color filter substrate and includes a plurality of gate lines 41 and a plurality of data lines 42 on a substrate 70, wherein each gate line 41 is orthogonal to each data line 42 to thereby define each pixel region. In addition, a common line 47 is formed in parallel to the gate line 41, and common electrodes 47a are diverged from the common line 47 toward the inside of pixel region, wherein the common electrodes 47a are formed at fixed intervals. At each crossing of the gate and data lines 41 and 42, there is a thin film transistor TFT including source and drain electrodes 42a and 42b. Pixel electrodes 43 are connected to the drain electrode of the thin film transistor within the pixel region, wherein the pixel electrodes 43 alternate with and are substantially parallel to the common electrodes 47a within the pixel region.

[0047] The substrates 60 and 70 may be formed of glass or plastic. A gate insulation film 45 is formed between the gate line 41 and the data line 42. A semiconductor layer 44 is formed on the gate insulation film 45 above the gate electrode 41a. A passivation film 46a is formed between the thin film transistor TFT and the pixel electrode 43. Simultaneously with the forming of the passivation film 46a, a column spacer 46b is formed of the same material as the passivation film 46a.

[0048] The column spacer 46b maintains a cell gap between the two substrates when the column spacer 46b is brought into contact with the color filter substrate 100. The passivation film 46a and the column spacer 46b are formed as an integral body by depositing an organic insulation material of ultra-violet curable liquid pre-polymer on the substrate 70

including the thin film transistor TFT, and carrying out In-Plane Printing using a soft mold provided with a pattern having an inverted shape corresponding to the shapes of the passivation film 46a and the column spacer 46b.

[0049] Accordingly, the liquid crystal display device according to the first embodiment of the present invention includes the passivation film 46a and the column spacer 46b which are formed by the In-Plane Printing using a soft mold. In comparison to a related art process of forming a column spacer by photolithography using coating, exposure and development of photoresist, the In-Plane Printing using the soft mold process can realize a simpler process with a lower fabrication cost.

[0050] FIGS. 4A to 4D are cross section diagrams illustrating a method of fabricating the liquid crystal display device according to the first embodiment of the present invention.

[0051] Referring to FIG. 4A, after forming a gate metal layer on the substrate 70, the gate metal layer is patterned by photolithography, thereby forming gate patterns including the gate line 41 and a gate electrode 41a, as shown in FIG. 4A. The gate insulation film 45 is formed on the substrate 70 including the gate patterns.

[0052] Subsequently, a layer of n+-type amorphous silicon is formed on the substrate 70 including the gate insulation film 45, and the n+-type amorphous silicon layer is then patterned by photolithography to form the semiconductor layer 44. The semiconductor layer 44 is formed in a double-layered structure including an active layer and an ohmic contact layer. A source/drain metal layer is formed on the substrate 70 including the semiconductor layer 44, and is patterned by photolithography to form source/drain patterns including the data line 42, and the source and drain electrodes 42a and 42b. A pattern material layer 46 is formed on the substrate 70 including the source/drain patterns.

[0053] The pattern material layer 46 includes ultra-violet curable liquid pre-polymer, photo-initiator and surfactant. Typically, the ultra-violet curable liquid pre-polymer uses a ultra-violet curable acrylate pre-polymer such as, HEA (2-Hydroxyethyl acrylate), EGDMA (Ethylene glycol dimethacrylate), EGPEA (Ethylene glycol phenyletheracrylate), HPA (Hydroxypropyl acrylate), and HPPA (Hydroxyl phenoxypropyl acrylate).

[0054] A soft mold 300 is prepared. The rear surface of the soft mold 300 is provided with a backplane and the front surface is provided with embossing patterns 300b and depressed patterns 300a and positioned above the substrate including the pattern material layer 46. The soft mold 300 may be fabricated by curing an elastic polymer such as PDMS (polydimethylsiloxane). Alternatively, the soft mold 300 may be formed of polyurethane or polyimide. The soft mold 300 is provided with the embossing pattern 300b for forming a contact hole, and the depressed pattern 300a for formation of the column spacer.

[0055] As shown in FIG. 4B, after aligning the soft mold 300 and the substrate 70 having the pattern material layer 46, the surface of soft mold 300 is brought into contact with the pattern material layer 46 to thereby form the passivation film 46a, the column spacer 46b, and the contact hole 46d for exposing the drain electrode 42b in the pattern material layer 46. The column spacer 46b corresponds to the depressed pattern 300a of the soft mold 300, and the contact hole 46d corresponds to the embossing pattern 300b of the soft mold 300. While the soft mold 300 is in contact with the pattern

material layer 46, heat or light is applied thereto to thereby cure the pattern material layer 46.

[0056] As shown in FIG. 4C, the soft mold 300 is separated from the passivation film 46a including the contact hole 46d and the pattern material layer 46 having the column spacer 46b. Next, as shown in FIG. 4D, a transparent conductive film is formed on the passivation film 46a having the contact hole 46d, and a transparent conductive film is patterned by photolithography to form the pixel electrode 43 connected to the drain electrode 42b.

[0057] Accordingly, the passivation film 46a and the column spacer 46b are formed by In-Plane Printing using the soft mold. In comparison to a related art process of forming a column spacer by photolithography using coating, exposure and development of photoresist, the In-Plane Printing using the soft mold can realize a simpler process with decreased fabrication cost.

[0058] A liquid crystal display device provided with a passivation film having a double-layered structure and a cell-gap column spacer and a method of fabricating the same will be explained as follows.

[0059] FIG. 5 is a cross section diagram illustrating a liquid crystal display device according to a second embodiment of the present invention, along I-I' and II-II' of FIG. 2.

[0060] First, as shown in FIGS. 2 and 5, the liquid crystal display device according to the second embodiment of the present invention includes a color filter substrate 100, a TFT substrate 200, and a liquid crystal layer 55 formed by injecting liquid crystal into a space between the color filter substrate 100 and the TFT substrate 200.

[0061] The color filter substrate 100 includes a substrate 60, a black matrix layer 31, an R/G/B color filter layer 32, and an overcoat layer (not shown). The TFT substrate 200 positioned opposite the color filter substrate 100 includes a substrate 70, a gate line 41, a data line 42, a common line 47, a common electrode 47a, source and drain electrodes 42a and 42b, a pixel electrode 43, a gate insulation film 45, and a semiconductor layer 44. The substrates 60 and 70 may be formed of glass or plastic.

[0062] In addition, a first passivation film 48 and a second passivation film 46a are formed between the thin film transistor TFT and the pixel electrode 43. Simultaneously with forming the second passivation film 46a, a column spacer 46b is formed of the same material as the second passivation film 46a. The column spacer 46b maintains a cell gap between the two substrates when the column spacer 46b is brought into contact with the color filter substrate 100. The column spacers 57 are provided at fixed intervals on the gate line 41.

[0063] The first passivation film 48 is formed of an inorganic insulation material such as SiN_x, to thereby improve the interfacial stability between the second passivation film 46a of organic insulation material including photo ultra-violet curable liquid pre-polymer and the source and drain electrodes 42a and 42b/data line 42/gate insulation film 45. The second passivation film 46a and the column spacer 46b are formed as an integral body by depositing an organic insulation material of ultra-violet curable liquid pre-polymer on the substrate 70 including the thin film transistor TFT and the first passivation film 48, and carrying out In-Plane Printing using a soft mold provided with a pattern having an inverted shape of the second passivation film 46a and the column spacer 46b.

[0064] Accordingly, the liquid crystal display device according to the second embodiment of the present invention includes the second passivation film 46a and the column

spacer **46b** which are formed by the In-Plane Printing using the soft mold. In comparison to a related art process of forming a column spacer by photolithography using coating, exposure and development of photoresist, the In-Plane Printing using the soft mold can realize a simpler process with decreased fabrication cost. Furthermore, since the first passivation film **48** of inorganic insulation material is formed under the second passivation film **46a**, the interfacial stability is improved between the second passivation film **46a** of organic insulation material and the contacting layers.

[0065] FIGS. 6A to 6E are cross section diagrams illustrating a method of fabricating a liquid crystal display device according to the second embodiment of the present invention.

[0066] As shown in FIG. 6A, a gate pattern including the gate line **41** and a gate electrode **41a**, the gate insulation film **45**; the semiconductor layer **44**, and source/drain patterns including the data line **42** and the source and drain electrodes **42a** and **42b** are formed the substrate **70**. The first passivation film **48** of inorganic insulation material, for example, SiN_x is formed on the substrate **70**, and a pattern material layer **46** is formed on the first passivation film **48**.

[0067] Thereafter, a soft mold **300** is prepared having a rear surface provided with a backplane and a front surface provided with embossing patterns **300b** and depressed patterns **300a** and positioned above the substrate **70** including the pattern material layer **46**. The soft mold **300** is provided with the embossing pattern **300b** for forming the contact hole, and the depressed pattern **300a** for forming the column spacer.

[0068] As shown in FIG. 6B, after aligning the soft mold **300** and the substrate **70** having the pattern material layer **46**, the front surface of soft mold **300** is brought into contact with the pattern material layer **46**, thereby forming the second passivation film **46a**, the column spacer **46b** and the contact hole **46d** for exposing the drain electrode **42b** in the pattern material layer **46**, wherein the column spacer **46b** corresponds to the depressed pattern **300a** of the soft mold **300**, and the contact hole **46d** corresponds to the embossing pattern **300b** of the soft mold **300**. While the soft mold **300** is in contact with the pattern material layer **46**, heat or light is applied thereto to thereby cure the pattern material layer **46**.

[0069] Next, as shown in FIG. 6C, the soft mold **300** is separated from the second passivation film **46a** having the contact hole **46d** and the pattern material layer **46** having the column spacer **46b**.

[0070] As shown in FIG. 6D, an etching process is performed using the second passivation film **46a** having the contact hole **46d** as an etching mask to thereby form the contact hole **46d** in the first passivation layer **48** for exposing the drain electrode **42b**.

[0071] As shown in FIG. 6E, a transparent conductive film is formed on the substrate **70** including the contact hole **46d**, and the transparent conductive film is patterned by photolithography to form the pixel electrode **43** connected to the drain electrode **42b**.

[0072] Accordingly, the liquid crystal display device according to the second embodiment of the present invention includes the second passivation film **46a** and the column spacer **46b** formed by In-Plane Printing using the soft mold. In comparison to a related art process of forming a column spacer by photolithography using coating, exposure and development of photoresist, the In-Plane Printing using the soft mold can realize a simpler process with decreased fabrication cost. Furthermore, the first passivation film **48** of inorganic insulation material is formed under the second passiva-

tion film **46a** of organic insulation material to thereby improve the interfacial stability between the second passivation film **46a** of organic insulation material and the contacting layers.

[0073] A liquid crystal display device provided with a passivation film having a three-layered structure and a cell-gap column spacer and a method of fabricating the same will be explained as follows.

[0074] FIG. 7 is a cross section diagram illustrating a liquid crystal display device according to the third embodiment of the present invention, along I-I' and II-II' of FIG. 2.

[0075] As shown in FIGS. 2 and 7, the liquid crystal display device according to the third embodiment of the present invention includes a color filter substrate **100**, a TFT substrate **200**, and a liquid crystal layer **55** formed by injecting liquid crystal into a space between the color filter substrate **100** and the TFT substrate **200**.

[0076] The color filter substrate **100** includes a substrate **60**, a black matrix layer **31**, an R/G/B color filter layer **32**, and an overcoat layer (not shown). The TFT substrate **200** positioned opposite to the color filter substrate **100** includes a substrate **70**, a gate line **41**, a data line **42**, a common line **47**, a common electrode **47a**, source and drain electrodes **42a** and **42b**, a pixel electrode **43**, a gate insulation film **45**, and a semiconductor layer **44**. The substrates **60** and **70** may be formed of glass or plastic.

[0077] In addition, a first passivation film **48**, a second passivation film **46a** and a third passivation film **49** are formed between the thin film transistor TFT and the pixel electrode **43**, and simultaneously with forming the second passivation film **46a**, a column spacer **46b** is formed of the same material as the second passivation film **46a**. The column spacer **46b** maintains a cell gap between the two substrates when the column spacer **46b** is brought into contact with the color filter substrate **100**.

[0078] The first and third passivation films **48** and **49** are formed of an inorganic insulation material such as SiN_x . Thus, the first passivation film **48** is provided to improve the interfacial stability between the second passivation film **46a** of organic insulation material including photo ultra-violet curable liquid pre-polymer and the source and drain electrodes **42a** and **42b**/data line **42**/gate insulation film **45**. The third passivation film **49** is provided to improve the interfacial stability between the second passivation film **46a** and the pixel electrode **43**.

[0079] The second passivation film **46a** and the column spacer **46b** are formed as an integral body by depositing an organic insulation material of ultra-violet curable liquid pre-polymer on the substrate **70** including the thin film transistor TFT, and carrying out In-Plane Printing using a soft mold provided with a pattern having an inverted shape of the second passivation film **46a** and the column spacer **46b**.

[0080] Accordingly, the liquid crystal display device according to the third embodiment of the present invention includes the second passivation film **46a** and the column spacer **46b** which are formed by the In-Plane Printing using the soft mold. In comparison to a related art process of forming a column spacer by photolithography using coating, exposure and development of photoresist, the In-Plane Printing using the soft mold can realize a simpler process with decreased fabrication cost. Furthermore, since the first and third passivation film **48** and **49** of inorganic insulation material are respectively formed on and under the second passiva-

tion film **46a**, the interfacial stability is improved between the second passivation film **46a** of organic insulation material and the contacting layers.

[0081] A method of fabricating the liquid crystal display device according to the present invention will be explained with reference to FIGS. **8A** and **8B**.

[0082] The process up until forming the column spacer **46b**, the passivation film **46a** and the contact hole **46d** for exposing the drain electrode **42b** is same as the process of FIGS. **6A** to **6D** according to the second embodiment of the present invention. Thereafter, as shown in FIG. **8A**, the third passivation film **49** of inorganic insulation material, for example, SiN_x is formed on the second passivation film **46a**.

[0083] Then, as show in FIG. **8B**, a transparent conductive film is formed on the substrate **70** including the contact hole **46d**, and is then patterned by photolithography, thereby forming the pixel electrode **43** connected to the drain electrode **42b**, and completing the process.

[0084] Accordingly, the liquid crystal display device according to the third embodiment of the present invention includes the second passivation film **46a** and the column spacer **46b** formed by In-Plane Printing using the soft mold. In comparison to a related art process of forming a column spacer by photolithography using coating, exposure and development of photoresist, the In-Plane Printing using the soft mold can realize a simpler process with decreased fabrication cost. Furthermore, the first and third passivation films **48** and **49** of inorganic insulation material are respectively formed on and under the second passivation film of organic insulation material, thereby improving the interfacial stability between the second passivation film **46a** and the contacting layers.

[0085] A liquid crystal display device provided with a compression prevention column spacer **46c** as well as a cell-gap column spacer **46b** and a method of fabricating the same will be explained with reference to the accompanying drawings.

[0086] FIG. **9** is a plan diagram illustrating another liquid crystal display device according to the present invention. FIG. **10** is a cross section diagram illustrating a liquid crystal display device according to the fourth embodiment of the present invention, along I-I' and II-II' of FIG. **9**.

[0087] As shown in FIGS. **9** and **10**, the liquid crystal display device according to the fourth embodiment of the present invention includes a color filter substrate **100**, a TFT substrate **200**, and a liquid crystal layer **55** formed by injecting liquid crystal into a space between the color filter substrate **100** and the TFT substrate **200**.

[0088] The color filter substrate **100** includes a substrate **60**, a black matrix layer **31**, an R/G/B color filter layer **32**, and an overcoat layer (not shown). The TFT substrate **200** positioned in opposite to the color filter substrate **100** includes a substrate **70**, a gate line **41**, a data line **42**, a common line **47**, a common electrode **47a**, source and drain electrodes **42a** and **42b**, a pixel electrode **43**, a gate insulation film **45**, and a semiconductor layer **44**. The substrates **60** and **70** may be formed of glass or plastic.

[0089] In addition, a passivation film **46a** is formed between the thin film transistor TFT and the pixel electrode **43**. Simultaneously, first and second column spacers **46b** and **46c** are formed of the same material as the passivation film **46a**. The first column spacer **46b** corresponds to a cell-gap column spacer to maintain a cell gap between the two substrates, wherein the first column spacer **46b** is brought into contact with the color filter substrate **100**. The second column

spacer **46b** is provided to prevent a liquid crystal panel from being compressed, wherein the second column spacer **46b** has such a height as not to contact with the color filter substrate **100** when the liquid crystal panel is not compressed. Accordingly, the liquid crystal display device according to the fourth embodiment of the present invention is provided with dual column spacers including the first and second column spacers **46b** and **46c** to maintain the cell gap and to prevent the liquid crystal panel from being compressed.

[0090] The passivation film **46a** and the first and second column spacers **46b** and **46c** are formed as an integral body by depositing an organic insulation material of ultra-violet curable liquid pre-polymer on the substrate **70** including the thin film transistor TFT, and carrying out In-Plane Printing using a soft mold provided with a pattern having an inverted shape of the passivation film **46a** and the first and second column spacers **46b** and **46c**.

[0091] Accordingly, the liquid crystal display device according to the fourth embodiment of the present invention includes the passivation film **46a** and the first and second column spacers **46b** and **46c** which are formed by the In-Plane Printing using the soft mold. In comparison to a related art process of forming a column spacer by photolithography using coating, exposure and development of photoresist, the In-Plane Printing using the soft mold can realize a simpler process with decreased fabrication cost.

[0092] A method of fabricating the liquid crystal display device according to the fourth embodiment of the present invention will be explained with reference to FIGS. **11A** to **11D**.

[0093] As shown in FIG. **11A**, a gate pattern including the gate line **41** and a gate electrode **41a**, the gate insulation film **45**; the semiconductor layer **44**, and source/drain patterns including the data line **42** and the source and drain electrodes **42a** and **42b** are formed on the substrate **70**.

[0094] Thereafter, a soft mold **300** is prepared having a rear surface provided with a backplane and a front surface provided with embossing patterns **300b** and depressed patterns **300a** and **300c** and positioned above the substrate **70** including the pattern material layer **46**. The soft mold **300** is provided with the embossing pattern **300b** for formation of the contact hole, and the depressed pattern **300a** and **300c** for formation of the first and second column spacers **46b** and **46c**.

[0095] As shown in FIG. **11B**, after aligning the soft mold **300** and the substrate **70** having the pattern material layer **46**, the surface of soft mold **300** is brought into contact with the pattern material layer **46**, thereby forming the passivation film **46a**, the first and second column spacer **46b** and **46c**, and the contact hole **46d** for exposing the drain electrode **42b** in the pattern material layer **46**, wherein the first and second column spacer **46b** and **46c** correspond to the depressed patterns **300a** and **300c** of the soft mold **300**, and the contact hole **46d** corresponds to the embossing pattern **300b** of the soft mold **300**. While the soft mold **300** is in contact with the pattern material layer **46**, heat or light is applied thereto to thereby cure the pattern material layer **46**. The first column spacer **46b** has such a height as to contact the color filter substrate **100**. The second column spacer **46c** has such a height as not to contact with the color filter substrate **100**, wherein the second column spacer **46c** prevents the liquid crystal panel from being compressed.

[0096] As shown in FIG. **11C**, the soft mold **300** is separated from the passivation film **46a** having the contact hole

46d and the pattern material layer 46 having the first and second column spacers 46b and 46c.

[0097] Next, as shown in FIG. 11D, a transparent conductive film is formed on the passivation film 46a having the contact hole 46d, and is then patterned by photolithography, thereby forming the pixel electrode 43 connected to the drain electrode 42b.

[0098] Accordingly, the liquid crystal display device according to the fourth embodiment of the present invention includes the passivation film 46a and the first and second column spacers 46b and 46c formed by In-Plane Printing using the soft mold. In comparison to a related art process of forming a column spacer by photolithography using coating, exposure and development of photoresist, the In-Plane Printing using the soft mold can realize a simpler process with decreased fabrication cost.

[0099] A liquid crystal display device provided with a passivation film having a dual-layered structure, a cell-gap column spacer 46b and a compression prevention column spacer 46c and a method of fabricating the same will be explained with reference to the accompanying drawings.

[0100] FIG. 12 is a cross section diagram illustrating a liquid crystal display device according to the fifth embodiment of the present invention, along I-I' and II-II' of FIG. 9.

[0101] As shown in FIGS. 9 and 12, the liquid crystal display device according to the fifth embodiment of the present invention includes a color filter substrate 100, a TFT substrate 200, and a liquid crystal layer 55 formed by injecting liquid crystal into a space between the color filter substrate 100 and the TFT substrate 200.

[0102] The color filter substrate 100 includes a substrate 60, a black matrix layer 31, an R/G/B color filter layer 32, and an overcoat layer (not shown). The TFT substrate 200 positioned in opposite to the color filter substrate 100 includes a substrate 70, a gate line 41, a data line 42, a common line 47, a common electrode 47a, source and drain electrodes 42a and 42b, a pixel electrode 43, a gate insulation film 45, and a semiconductor layer 44. The substrates 60 and 70 may be formed of glass or plastic.

[0103] In addition, first and second passivation films 48 and 46a are formed between the pixel electrode 43 and the thin film transistor TFT, and simultaneously first and second column spacers 46b and 46c are formed of the same material as the second passivation film 46a. The first column spacer 46b corresponds to a cell-gap column spacer to maintain a cell gap between the two substrates, wherein the first column spacer 46b is brought into contact with the color filter substrate 100. The second column spacer 46c is provided to prevent a liquid crystal panel from being compressed, wherein the second column spacer 46c has such a height as not to contact with the color filter substrate 100. Accordingly, the liquid crystal display device according to the fifth embodiment of the present invention is provided with dual column spacers including the first and second column spacers 46b and 46c to maintain the cell gap and to prevent the liquid crystal panel from being compressed.

[0104] The first passivation film 48 is formed of an inorganic insulation material such as SiN_x, to thereby improve the interfacial stability between the second passivation film 46a of organic insulation material including photo ultra-violet curable liquid pre-polymer and the source and drain electrodes 42a and 42b/data line 42/gate insulation film 45. Additionally the second passivation film 46a and the first and second column spacers 46b and 46c are formed as an integral

body by depositing an organic insulation material of ultra-violet curable liquid pre-polymer on the substrate 70 including the thin film transistor TFT, and carrying out In-Plane Printing using a soft mold provided with a pattern having an inverted shape of the second passivation film 46a and the first and second column spacers 46b and 46c.

[0105] Accordingly, the liquid crystal display device according to the fifth embodiment of the present invention includes the second passivation film 46a and the first and second column spacers 46b and 46c which are formed by the In-Plane Printing using the soft mold. In comparison to a related art process of forming a column spacer by photolithography using coating, exposure and development of photoresist, the In-Plane Printing using the soft mold can realize a simpler process with decreased fabrication cost. Furthermore, the first passivation film 48 of inorganic insulation material is formed under the second passivation film 46a of organic insulation material, thereby improving the interfacial stability between the second passivation film 46a and the contacting layers.

[0106] A method of fabricating the liquid crystal display device according to the fifth embodiment of the present invention will be explained with reference to FIGS. 13A to 13E.

[0107] As shown in FIG. 13A, there are a gate pattern including the gate line 41 and a gate electrode 41a; the gate insulation film 45; the semiconductor layer 44; and source/drain patterns including the data line 42 and the source and drain electrodes 42a and 42b on the substrate 70. The first passivation film 48 of inorganic insulation material, for example, SiN_x is formed on the substrate 70 including the source/drain patterns, and a pattern material layer 46 is formed on the first passivation film 48.

[0108] Thereafter, a soft mold 300 is prepared having a rear surface provided with a backplane and a front surface provided with embossing patterns 300b and depressed patterns 300a and 300c and positioned above the substrate 70 including the pattern material layer 46. The soft mold 300 is provided with the embossing pattern 300b for formation of the contact hole, and the depressed pattern 300a and 300c for formation of the first and second column spacers.

[0109] As shown in FIG. 13B, after aligning the soft mold 300 and the substrate 70 having the pattern material layer 46, the surface of soft mold 300 is brought into contact with the pattern material layer 46, thereby forming the second passivation film 46a, the first and second column spacer 46b and 46c, and the contact hole 46d for exposing the drain electrode 42b in the pattern material layer 46, wherein the first and second column spacers 46b and 46c correspond to the depressed patterns 300a and 300c of the soft mold 300, and the contact hole 46d corresponds to the embossing pattern 300b of the soft mold 300. While the soft mold 300 is in contact with the pattern material layer 46, heat or light is applied thereto to thereby cure the pattern material layer 46.

[0110] The first column spacer 46b corresponds to the cell-gap column spacer to maintain the cell gap between the two substrates, wherein the first column spacer 46b is brought into contact with the color filter substrate 100. The second column spacer 46c is provided to prevent the liquid crystal panel from being compressed, wherein the second column spacer 46c has such a height as not to contact with the color filter substrate 100.

[0111] Next, as shown in FIG. 13C, the soft mold 300 is separated from the second passivation film 46a having a hole

46e corresponding to the contact hole and the pattern material layer 46 having the first and second column spacers 46b and 46c.

[0112] As shown in FIG. 13D, an etching process is performed using the second passivation film 46a having the hole 46e corresponding to the contact hole as an etching mask, thereby forming the contact hole 46d for exposing the drain electrode 42b.

[0113] As shown in FIG. 13E, a transparent conductive film is formed on the second passivation film 46a including the contact hole 46d, and is then patterned by photolithography, thereby forming the pixel electrode 43 connected to the drain electrode 42b and completing the process.

[0114] Accordingly, the liquid crystal display device according to the fifth embodiment of the present invention includes the second passivation film 46a and the first and second column spacers 46b and 46c formed by In-Plane Printing using the soft mold. In comparison to a related art process of forming a column spacer by photolithography using coating, exposure and development of photoresist, the In-Plane Printing using the soft mold can realize a simpler process with decreased fabrication cost. Furthermore, the first passivation film 48 of inorganic insulation material is formed under the second passivation film 46a of organic insulation material, whereby the interfacial stability improves between the second passivation film 46a of organic insulation material and the contacting layers.

[0115] A liquid crystal display device provided with a passivation film having a three-layered structure, a cell-gap column spacer 46b and a compression prevention column spacer 46c and a method of fabricating the same will be explained as follows.

[0116] FIG. 14 is a cross section diagram illustrating a liquid crystal display device according to the sixth embodiment of the present invention, along I-I' and II-II' of FIG. 9.

[0117] As shown in FIGS. 9 and 14, the liquid crystal display device according to the sixth embodiment of the present invention includes a color filter substrate 100, a TFT substrate 200, and a liquid crystal layer 55 formed by injecting liquid crystal into a space between the color filter substrate 100 and the TFT substrate 200.

[0118] The color filter substrate 100 includes a substrate 60, a black matrix layer 31, an R/G/B color filter layer 32, and an overcoat layer (not shown). The TFT substrate 200 positioned in opposite to the color filter substrate 100 includes a substrate 70, a gate line 41, a data line 42, a common line 47, a common electrode 47a, source and drain electrodes 42a and 42b, a pixel electrode 43, a gate insulation film 45, and a semiconductor layer 44. The substrates 60 and 70 may be formed of glass or plastic.

[0119] In addition, a first passivation film 48, a second passivation film 46a and a third passivation film 49 are formed between the pixel electrode 43 and the thin film transistor TFT, and simultaneously with forming the second passivation film 46a, first and second column spacers 46b and 46c are formed of the same material as the second passivation film 46a. The first column spacer 46b corresponds to a cell-gap column spacer to maintain a cell gap between the two substrates, wherein the first column spacer 46b is brought into contact with the color filter substrate 100. The second column spacer 46c is provided to prevent a liquid crystal panel from being compressed, wherein the second column spacer 46c has such a height as not to contact the color filter substrate 100.

[0120] The first and third passivation films 48 and 49 are formed of an inorganic insulation material such as SiN_x . The first passivation film 48 improves the interfacial stability between the second passivation film 46a of organic insulation material including photo ultra-violet curable liquid pre-polymer and the source and drain electrodes 42a and 42b/data line 42/gate insulation film 45. In addition, the third passivation film 49 improves the interfacial stability between the pixel electrode 43 and the second passivation film 46a.

[0121] The second passivation film 46a and the first and second column spacers 46b and 46c are formed as an integral body by depositing an organic insulation material of ultra-violet curable liquid pre-polymer on the substrate 70 including the thin film transistor TFT, and carrying out In-Plane Printing using a soft mold provided with a pattern having an inverted shape of the second passivation film 46a and the first and second column spacers 46b and 46c.

[0122] Accordingly, the liquid crystal display device according to the sixth embodiment of the present invention includes the second passivation film 46a and the first and second column spacers 46b and 46c which are formed by the In-Plane Printing using the soft mold. In comparison to a related art process of forming a column spacer by photolithography using coating, exposure and development of photoresist, the In-Plane Printing using the soft mold can realize a simpler process with decreased fabrication cost. Furthermore, the first and third passivation films 48 and 49 of inorganic insulation material are respectively formed on and under the second passivation film 46a of organic insulation material, thereby improving the interfacial stability between the second passivation film 46a and the contacting layers.

[0123] FIGS. 15A and 15B are cross section diagrams illustrating a method of fabricating a liquid crystal display device according to the sixth embodiment of the present invention.

[0124] The process until forming the column spacer 46b, the passivation film 46a, the first and second column spacers 46b and 46c and the contact hole 46d for exposing the drain electrode 42b is same as the process of FIGS. 13A to 13D according to the fifth embodiment of the present invention. Thereafter, as shown in FIG. 15A, the third passivation film 49 of inorganic insulation material, for example, SiN_x is formed on the second passivation film 46a.

[0125] Then, as shown in FIG. 15B, a transparent conductive film is formed on the substrate 70 including the contact hole 46d, and is then patterned by photolithography, thereby forming the pixel electrode 43 connected to the drain electrode 42b.

[0126] Accordingly, the liquid crystal display device according to the sixth embodiment of the present invention includes the second passivation film 46a and the first and second column spacers 46b and 46c formed by In-Plane Printing using the soft mold. In comparison to a related art process of forming a column spacer by photolithography using coating, exposure and development of photoresist, the In-Plane Printing using the soft mold can realize a simpler process with decreased fabrication cost. Furthermore, the first and third passivation films 48 and 49 of inorganic insulation material are respectively formed above and below the second passivation film 46a of organic insulation material, whereby the interfacial stability is improved between the second passivation film 46a of organic insulation material and the contacting layers.

[0127] As mentioned above, liquid crystal display devices according to the present invention and the method of fabricating the same may have the following advantages.

[0128] The liquid crystal display device according to the present invention includes the passivation film and the column spacer which are formed by In-Plane Printing using the soft mold. In comparison to a related art process of forming a column spacer by photolithography using coating, exposure and development of photoresist, the In-Plane Printing using the soft mold can realize a simpler process with decreased fabrication cost.

[0129] In the liquid crystal display device according to the present invention, one or more passivation films of inorganic insulation material may be formed between the passivation film of organic insulation material and the contacting layers, thereby improving the interfacial stability between the passivation film of organic insulation material and the contacting layers.

[0130] It will be apparent to those skilled in the art that various modifications and variation can be made in the present invention without departing from the spirit or scope of the invention. Thus, it is intended that the present invention cover the modifications and variations of this invention provided they come within the scope of the appended claims and their equivalents.

What is claimed is:

1. A liquid crystal display device comprising:
 - a first substrate having a color filter and a second substrate having a thin film transistor, wherein the first and second substrates face each other;
 - a first passivation film formed on the thin film transistor; and
 - a first column spacer formed integrally with the first passivation film.
2. The liquid crystal display device of claim 1, wherein the first column spacer contacts the first substrate to maintain a predetermined spacing between the first substrate and the second substrate.
3. The liquid crystal display device of claim 1, further comprising a second column spacer formed integrally with the first passivation film.
4. The liquid crystal display device of claim 3, wherein a height of the first column spacer is different from a height of the second column spacer.
5. The liquid crystal display device of claim 4, wherein the height of the first column spacer is greater than the height of the second column spacer whereby the second spacer does not contact the first substrate.
6. The liquid crystal display device of claim 1, wherein the first passivation film and the first column spacer are formed of an organic insulation material including an ultra-violet curable liquid pre-polymer, a photo-initiator and a surfactant.
7. The liquid crystal display device of claim 3, wherein the first passivation film, the first column spacer, and the second column spacer are formed of an organic insulation material including ultra-violet curable liquid pre-polymer, photo-initiator and surfactant.
8. The liquid crystal display device of claim 1, further comprising a second passivation film between the thin film transistor and the first passivation film.
9. The liquid crystal display device of claim 8, further comprising a third passivation film on the first passivation film.

10. The liquid crystal display device of claim 9, wherein the second and third passivation films are formed of an inorganic insulation material.

11. The liquid crystal display device of claim 8, wherein the second passivation film is formed of an inorganic insulation material.

12. The liquid crystal display device of claim 1, wherein the second substrate includes:

- a gate line and data line crossing each other to define a pixel region on the second substrate; and
- a pixel electrode connected to a predetermined portion of the thin film transistor and formed in the pixel region, and a liquid crystal layer formed between the first and second substrates.

13. A method of fabricating a liquid crystal display device comprising:

- preparing a first substrate having a color filter;
- forming a thin film transistor on a second substrate facing the first substrate;
- forming a pattern material layer on the second substrate including the thin film transistor;
- aligning a soft mold with the second substrate including the pattern material layer;
- forming a contact hole, a first passivation film and a first column spacer by contacting the soft mold with the pattern material layer;
- separating the soft mold from the pattern material layer; and
- forming a pixel electrode that connects to the thin film transistor via the contact hole.

14. The method of claim 13, wherein the pattern material layer is formed of an organic insulation material including ultra-violet curable liquid pre-polymer, photo-initiator and surfactant.

15. The method of claim 13, wherein the soft mold is provided with embossing patterns for formation of the contact hole, and depressed patterns for formation of the first column spacer.

16. The method of claim 15, wherein the soft mold is formed of any one of polydimethylsiloxane, polyurethane and polyimide.

17. The method of claim 13, further comprising curing the pattern material layer by applying one of heat and light to the substrate while contacting the soft mold with the pattern material layer.

18. The method of claim 13, further comprising forming a second column spacer concurrently with forming the contact hole, the first passivation film and the first column spacer by contacting the soft mold with the pattern material layer.

19. The method of claim 18, wherein the first column spacer a height above the second substrate to contact the first substrate, and the second column spacer has a height different from the height of the first column spacer.

20. The method of claim 18, wherein the soft mold includes depressed patterns for forming the second column spacer.

21. The method of claim 13, further comprising forming a second passivation film between the pattern material layer and the substrate including the thin film transistor.

22. The method of claim 21, wherein forming a contact hole, a first passivation film and a first column spacer by contacting the soft mold with the pattern material layer includes exposing a portion of the second passivation film in the contact hole.

23. The method of claim 22, further comprising etching the second passivation film within the contact hole using the first passivation film as a mask to expose a portion of the drain electrode within the contact hole.

24. The method of claim 21, further comprising forming a third passivation film between the first passivation film and the pixel electrode.

25. A method of fabricating an array substrate for a liquid crystal display device comprising:

- forming a thin film transistor on a substrate;
- forming a pattern material layer on the substrate including the thin film transistor;

aligning a soft mold with the substrate including the pattern material layer;

forming a contact hole, a first passivation film and a first column spacer by contacting the soft mold to the pattern material layer;

separating the soft mold from the pattern material layer; and

forming a pixel electrode that connects to the thin film transistor via the contact hole.

* * * * *

专利名称(译)	液晶显示装置及其制造方法		
公开(公告)号	US20080246906A1	公开(公告)日	2008-10-09
申请号	US12/005615	申请日	2007-12-28
[标]申请(专利权)人(译)	金珍WUK 宋TAE JOON		
申请(专利权)人(译)	金珍WUK 宋TAE JOON		
当前申请(专利权)人(译)	金珍WUK 宋TAE JOON		
[标]发明人	KIM JIN WUK SONG TAE JOON		
发明人	KIM, JIN WUK SONG, TAE JOON		
IPC分类号	G02F1/1339 G02F1/1335 H01L21/02		
CPC分类号	G02F1/13394 G02F1/136227 G02F2001/13396 G02F2201/50		
优先权	1020070034743 2007-04-09 KR		
其他公开文献	US8107048		
外部链接	Espacenet USPTO		

摘要(译)

公开了一种液晶显示装置及其制造方法，以提供一种液晶显示装置，以简化工艺并降低制造成本，该液晶显示装置包括具有滤色器的第一基板和具有第二基板的第二基板。薄膜晶体管，其中第一和第二基板彼此面对，第一钝化膜形成在薄膜晶体管上，第一柱状隔离物与第一钝化膜一体形成。

