



(19) **United States**

(12) **Patent Application Publication**
Lin

(10) **Pub. No.: US 2004/0075799 A1**

(43) **Pub. Date: Apr. 22, 2004**

(54) **LIQUID CRYSTAL DISPLAY**

(52) **U.S. Cl. 349/130**

(75) **Inventor: Bi Ly Lin, Tainan (TW)**

(57) **ABSTRACT**

Correspondence Address:
**Finnegan, Henderson, Farabow,
Garrett & Dunner, L.L.P.**
1300 I Street, N.W.
Washington, DC 20005-3315 (US)

(73) **Assignee: CHI MEI OPTOELECTRONICS
CORP.**

A liquid crystal display mainly includes two substrates processed for vertical alignment and a liquid crystal having a negative dielectric constant anisotropy sealed between the two substrates. An array of slits is provided on pixel electrodes formed on one substrate. A light-shielding matrix and an array of protrusions is provided on the other substrate. Each of the first protrusions has a main body being arranged substantially in a zigzag pattern and in parallel to one another. The slits and the main bodies of the first protrusions are arranged alternately. The liquid crystal display is characterized in that the first protrusions have a plurality of breaks formed within the area of the light-shielding matrix.

(21) **Appl. No.: 10/270,496**

(22) **Filed: Oct. 16, 2002**

Publication Classification

(51) **Int. Cl.⁷ G02F 1/1337**

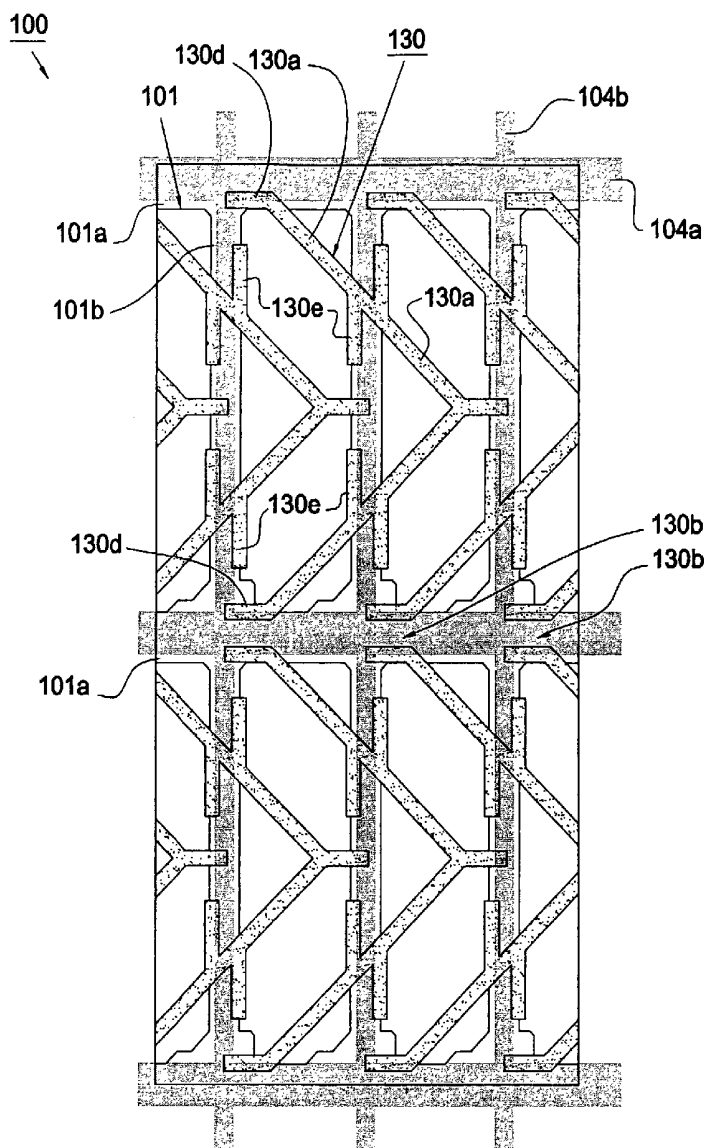

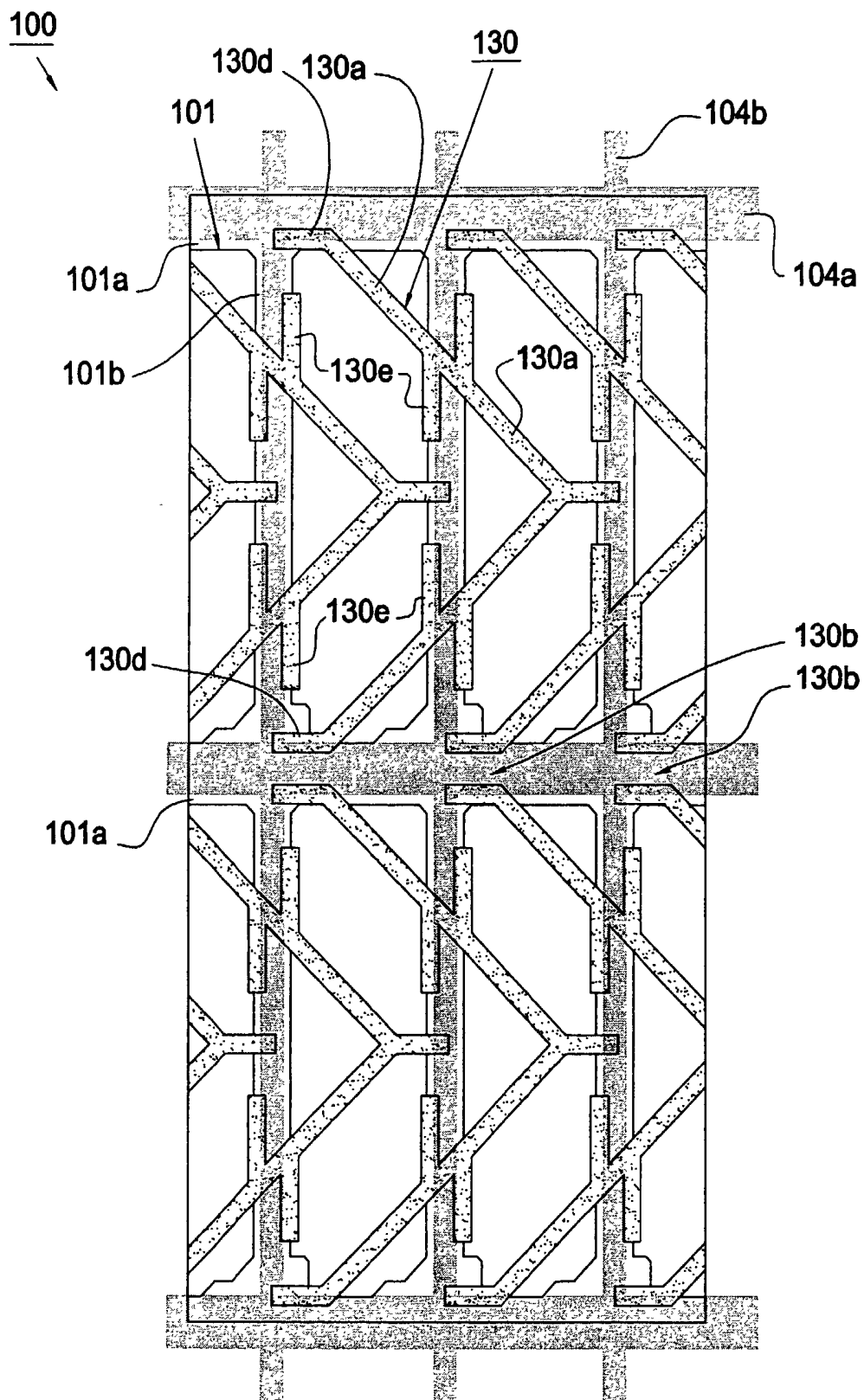

FIG. 1a

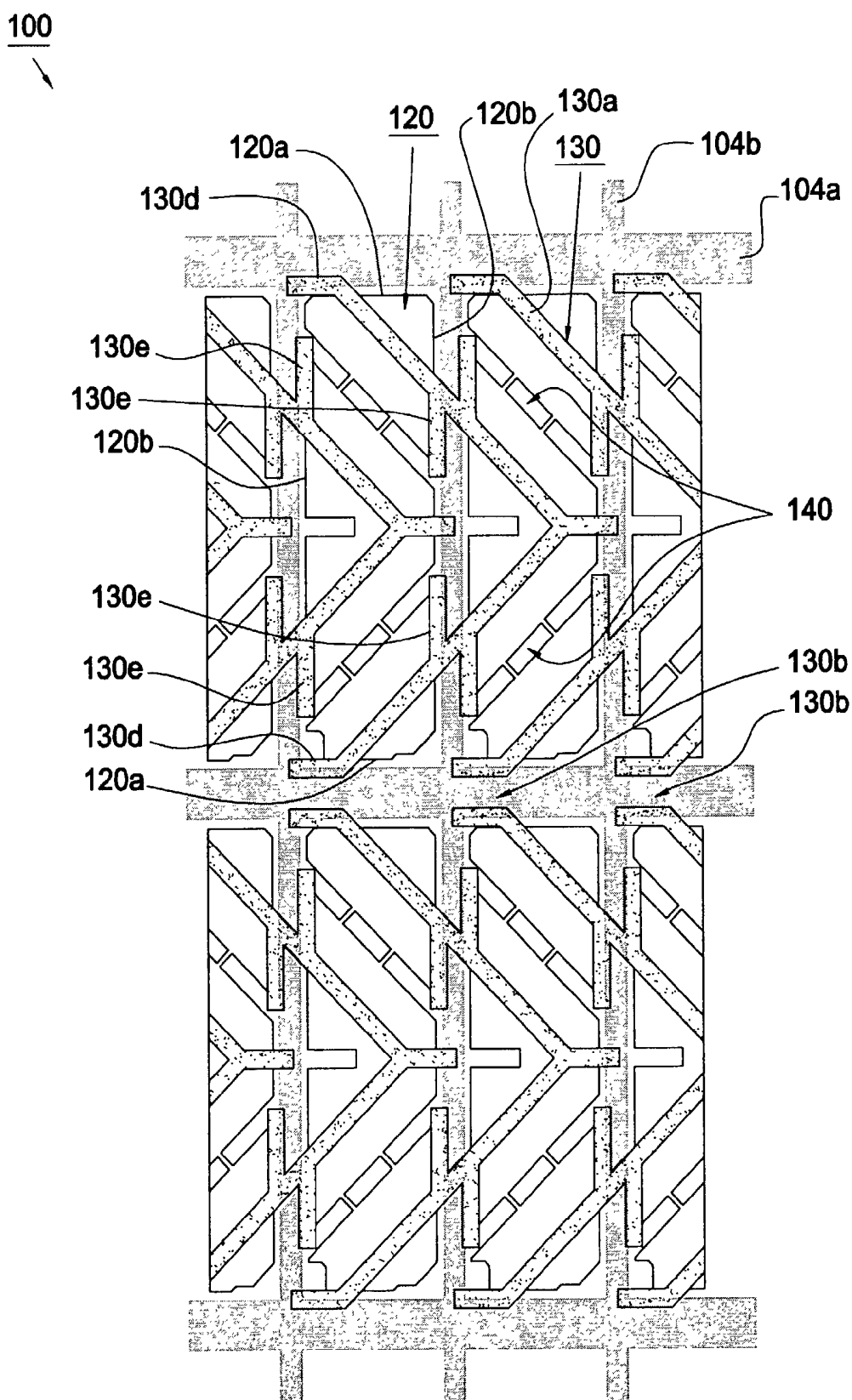

FIG. 1b

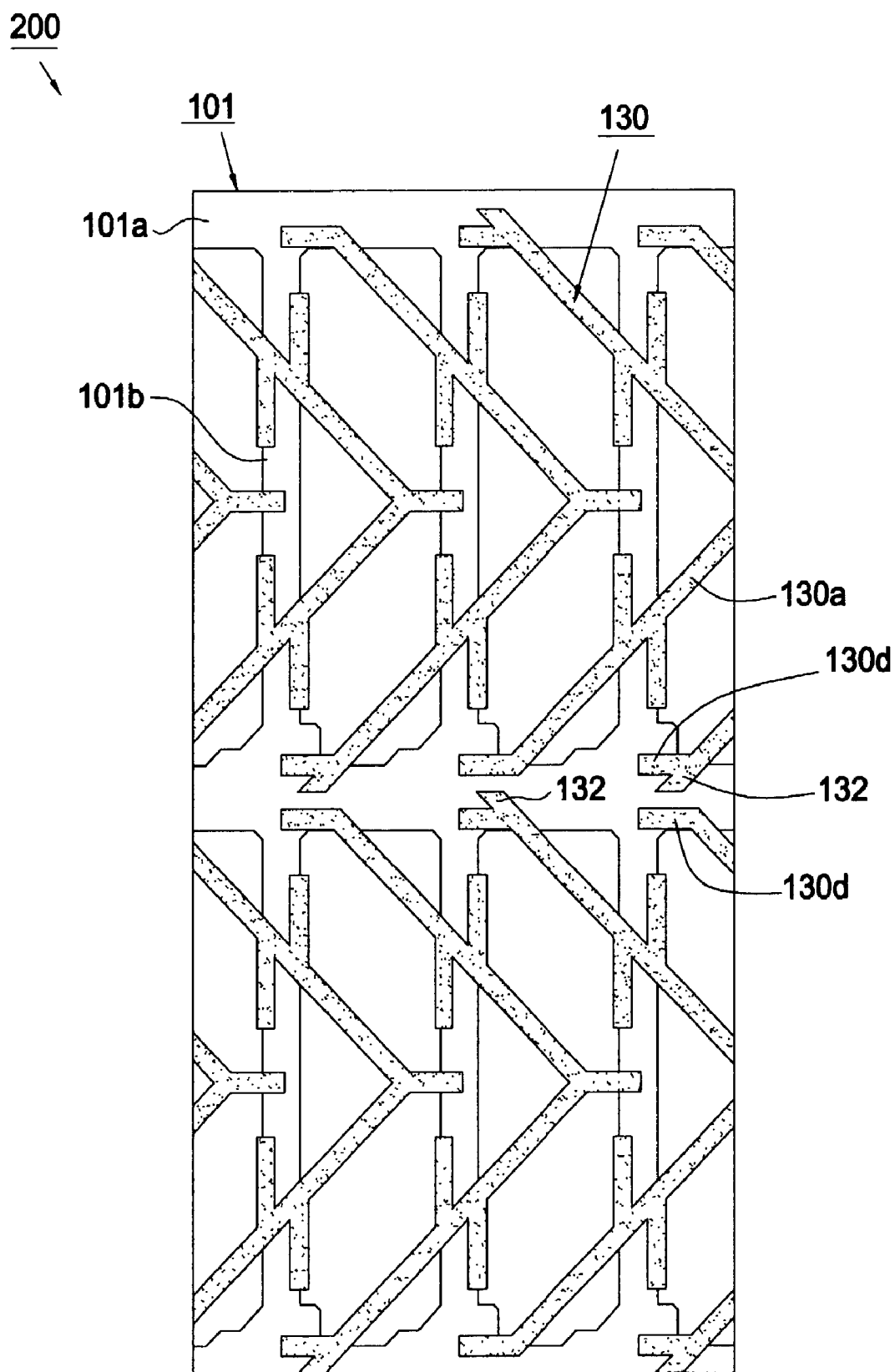

FIG. 2

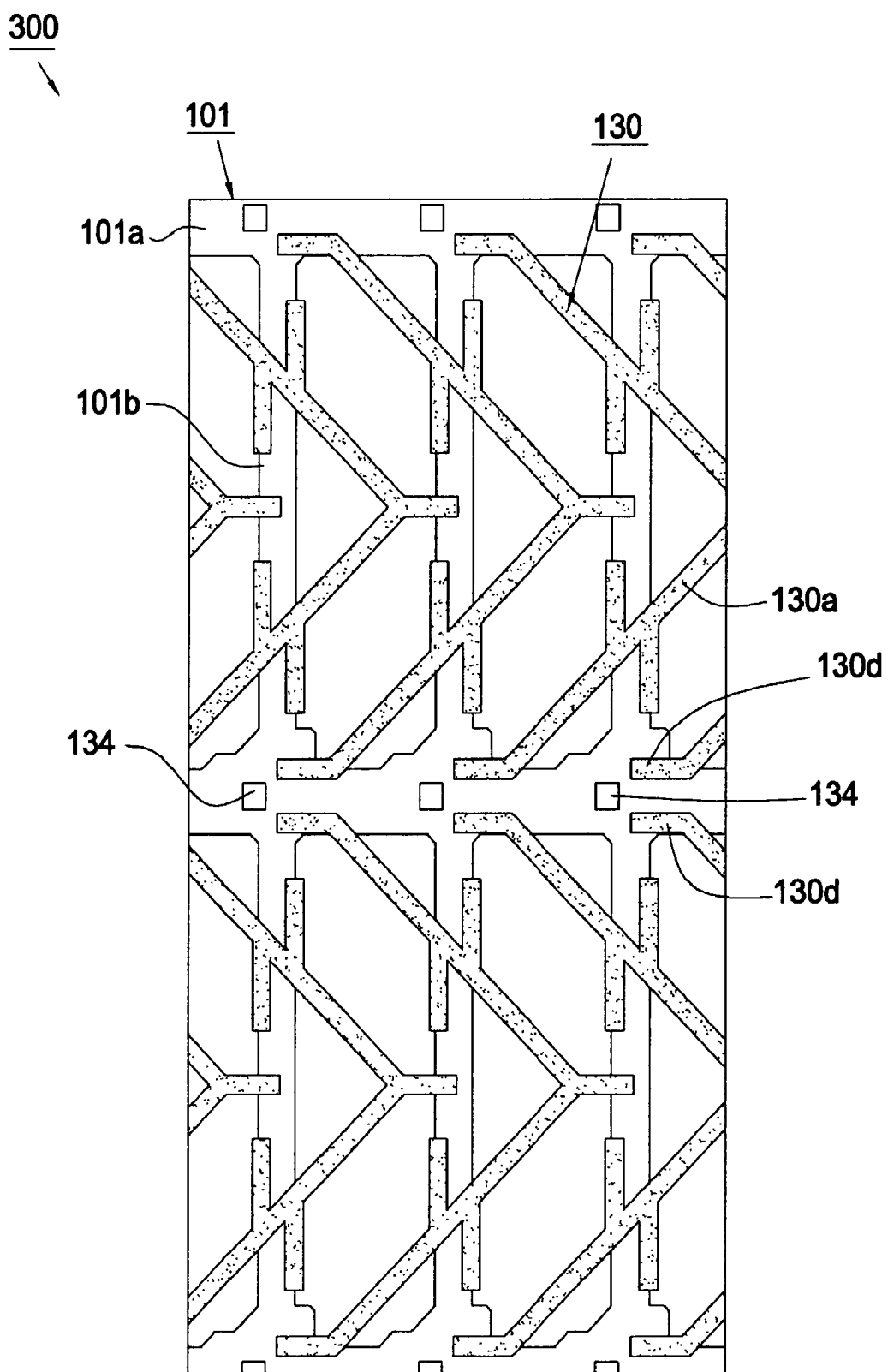

FIG. 3

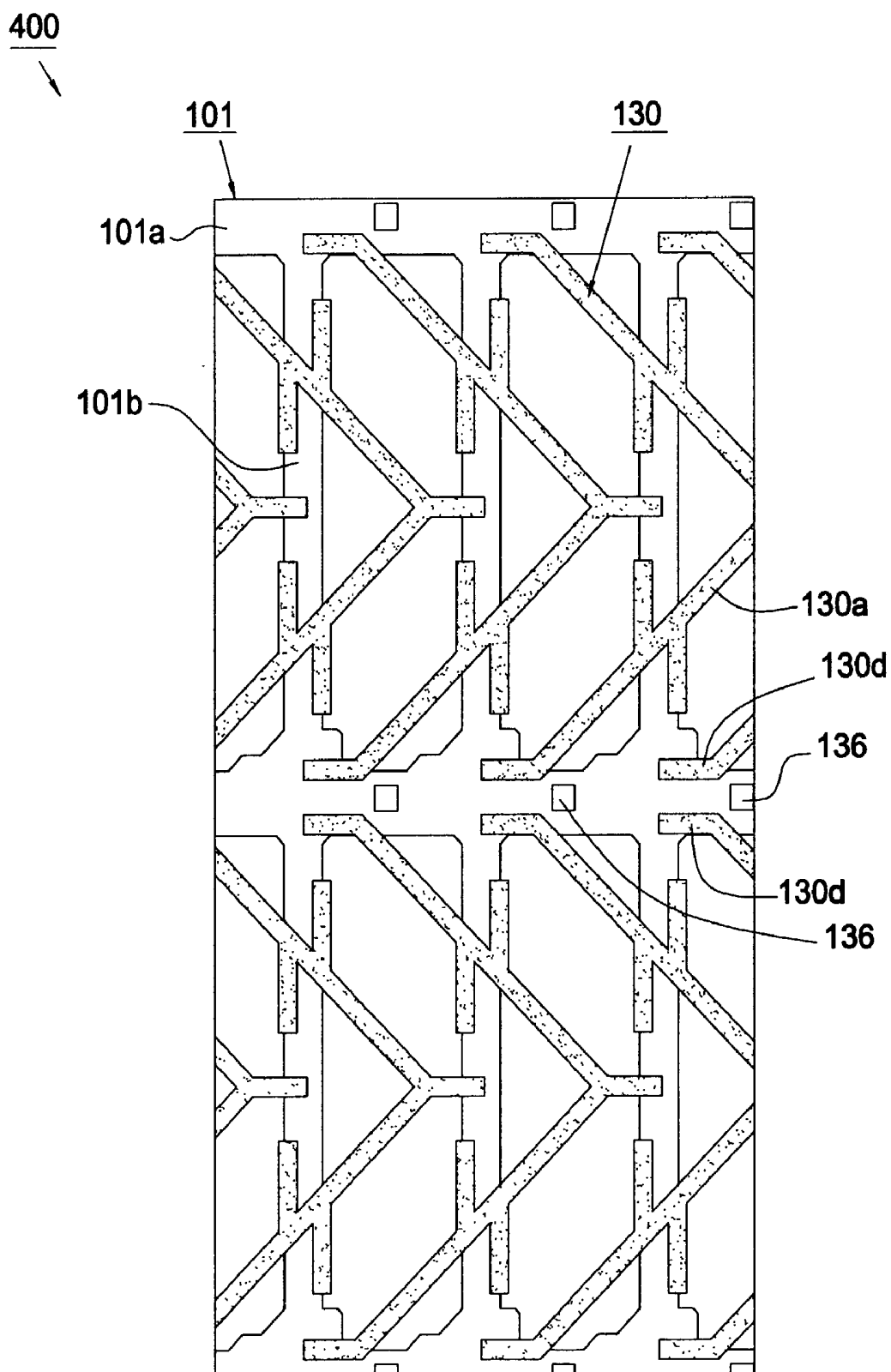

FIG. 4

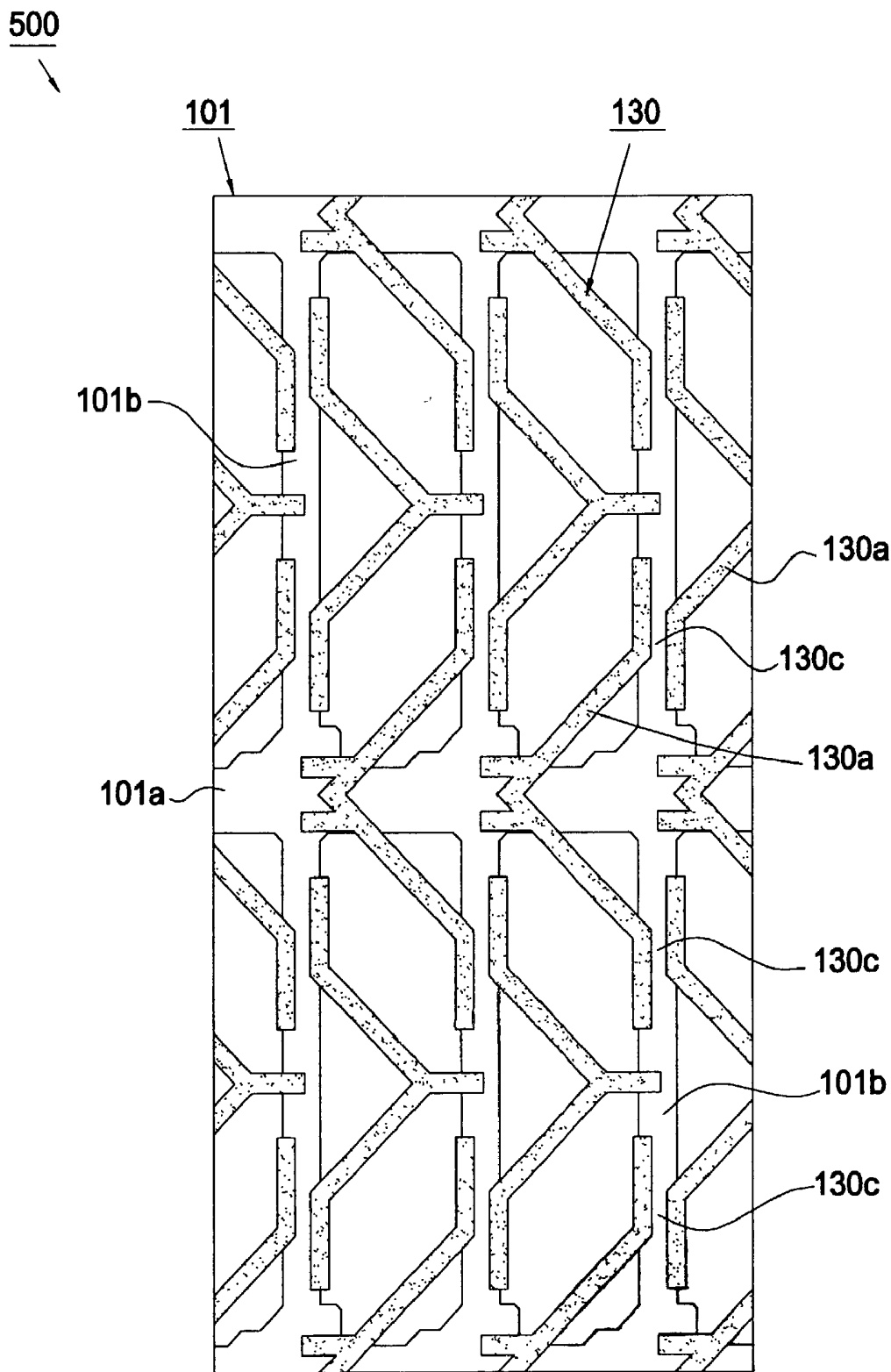

FIG. 5

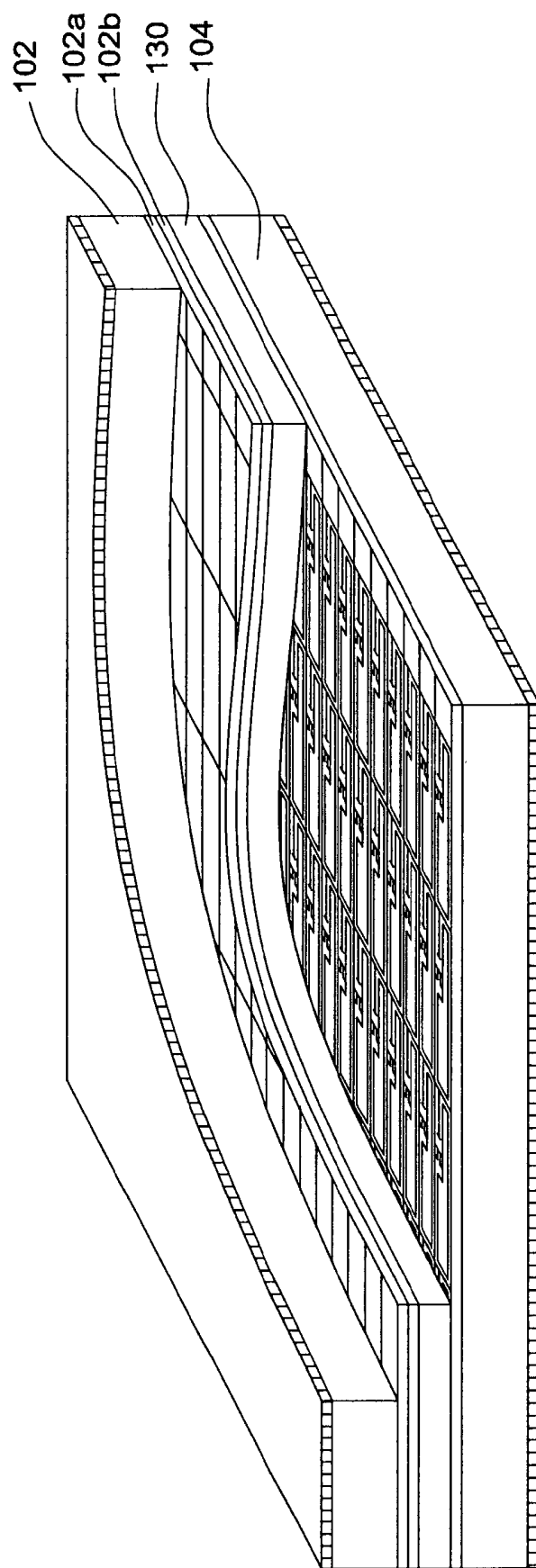

FIG. 6

LIQUID CRYSTAL DISPLAY

BACKGROUND OF THE INVENTION

[0001] 1 Field of the Invention

[0002] The present invention generally relates to a liquid crystal display (LCD), and more particularly to a multi-domain vertically aligned (MVA) LCD having specific protrusion pattern for use in a one drop fill (ODF) process.

[0003] 2. Description of the Related Art

[0004] Liquid crystal display mainly comprises two oppositely positioned first and second substrates and a liquid crystal layer interposed therebetween. U.S. Pat. No. 5,263,888 discloses a one drop fill (ODF) process comprising the steps of applying an adhesive onto the entire periphery of the first substrate, dropping the liquid crystal material to the first substrate, superposing the second substrate upon the first substrate and pressing the substrates until a gap between the substrates reaches a predetermined value (typically 3-10 micrometers), and curing the adhesive. In the step of pressing the substrates, the liquid crystal material spreads to fill the space between the substrates thereby forming the liquid crystal layer.

[0005] Vertically-aligned (VA) LCD is a mode using a negative liquid crystal material and vertical alignment films. Comparing with the twisted nematic (TN) LCD, the vertically-aligned (VA) LCD provides higher contrast, higher response speed, and excellent viewing angle characteristics for white display and black display. However, the VA LCD still has a critical drawback of a narrow viewing angle. This poses a problem that the application of the VA LCD is limited.

[0006] European Patent Publication Number 0884626-A2 discloses a multi-domain vertically aligned (MVA) LCD having domain regulating means for improving viewing angle performance thereof. Typically, the domain regulating means is realized by providing slits on the pixel electrodes of the TFT substrate and providing protrusions on the common electrode of the CF (color filter) substrate. The pattern of the protrusions is continuous and the protrusions are arranged in substantially the same way in all pixels. The protrusions typically have a height of around 1-2 μ . For an MVA LCD with a smaller cell gap (3-3.9 μ m) design, the spacing between the protrusions and the TFT substrate is about 2-2.9 μ m. If the MVA LCD is manufactured by the aforementioned ODF process, bubble is prone to be entrapped between the protrusions in a continuous pattern. In such a case, it may be found that an insufficient degree of spreading of the liquid crystal material will occur during the step of pressing the substrates thereby creating bubbles between the protrusions.

SUMMARY OF THE INVENTION

[0007] It is an object of the present invention to provide a multi-domain vertically aligned (MVA) LCD having discontinuous regulating means that overcomes or at least reduces the above-mentioned problems of the prior art.

[0008] To achieve the above listed and other objects, the LCD according to the present invention comprises a first substrate and a second substrate processed for vertical alignment, a liquid crystal being sandwiched between the

first and second substrates, and discontinuous regulating means provided on at least one of the first and second substrates. The liquid crystal layer includes liquid crystal molecules aligning in a direction generally perpendicular to a principal surface of said first substrate when no substantial electric field is applied to said liquid crystal layer. The discontinuous regulating means regulates orientation of the liquid crystal layer such that the liquid crystal molecules are aligned obliquely when a voltage is applied so that the orientation will include a plurality of directions within each pixel. Since the regulating means is formed in a discontinuous pattern, air trapped between the first and second substrates can be easily vented through the regulating means, thereby significantly reducing the occurring rate of bubbles.

[0009] According to one embodiment of the present invention, the discontinuous regulating means is realized by providing an array of first protrusions and slits wherein each of the first protrusions has a plurality of breaks formed therein. The first protrusions are formed on the second substrate wherein each of the first protrusions has a main body being arranged substantially in a zigzag pattern and in parallel to one another. The slits are provided on the pixel electrodes provided on the first substrate in a manner that the slits and the main bodies of the first protrusions are arranged alternately. The breaks of the first protrusions allow air trapped between the first protrusions to be easily vented therethrough, thereby significantly reducing the occurring rate of bubbles. Furthermore, during the step of pressing the substrates in the ODF process, the breaks of the first protrusions allows the dropped liquid crystal material to be spread more evenly such that the liquid crystal material will completely fill the cavity formed between the two substrates. However, since the pattern of the first protrusions is discontinuous, the orientation of the liquid crystal molecules is disordered at the edges of the breaks. This results in disclination generating around the edges of the breaks. Therefore, all of the breaks may be designed to have a predetermined size in order to achieve good air ventilation while minimizing disclination. Alternatively, all of the breaks may be formed within the area of the light-shielding matrix formed on the second substrate thereby significantly masking the deteriorated display quality such as light leakage due to disclination.

[0010] Typically, the second substrate may have a plurality of gate lines formed parallel to one another and a plurality of data lines formed parallel to one another vertically to the gate lines. The pixel electrodes have first edges parallel to the gate lines and second edges parallel to the data lines. The light-shielding matrix has a plurality of columns extending along the data lines and a plurality of rows extending along the gate lines. Therefore, all of the breaks may be designed to be located within the area of the rows and/or the columns of the light-shielding matrix such that none of the first protrusions extends across the rows and/or the columns of the light-shielding matrix.

[0011] Preferably, the first protrusions may have a plurality of first branches formed at positions facing the first edges of the pixel electrodes and a plurality of second branches formed at positions facing the second edges of the pixel electrodes. In this embodiment, the difference between the directors (i.e., the average direction of the long axes of the LC molecules) of the LC molecules around the branches and slits is significantly reduced down to at most 45 degrees.

This significantly suppresses disclination occurring at the border between the slits and the pixel electrode edges, thereby avoiding display defects due to the disclination.

[0012] According to another embodiment of the present invention, the second substrate further comprises a plurality of second protrusions formed inside one channel defined by two first branches extending from the main bodies of adjacent first protrusions and the first and second substrates.

[0013] According to still another embodiment of the present invention, the second substrate further comprises a plurality of third protrusions each formed at a location close to one channel defined by two first branches extending from the main bodies of adjacent first protrusions and the first and second substrates.

BRIEF DESCRIPTION OF THE DRAWINGS

[0014] Other objects, advantages, and novel features of the invention will become more apparent from the following detailed description when taken in conjunction with the accompanying drawings.

[0015] FIG. 1a is a plan view of a portion of an MVALCD showing specific protrusion pattern according to a first embodiment of the present invention;

[0016] FIG. 1b is a plan view of the MVA LCD of FIG. 1a showing specific protrusion and slit pattern;

[0017] FIG. 2 is a plan view of a portion of an MVALCD showing specific protrusion pattern according to a second embodiment of the present invention;

[0018] FIG. 3 is a plan view of a portion of an MVALCD showing specific protrusion pattern according to a third embodiment of the present invention;

[0019] FIG. 4 is a plan view of a portion of an MVALCD showing specific protrusion pattern according to a fourth embodiment of the present invention;

[0020] FIG. 5 is a plan view of a portion of an MVALCD showing specific protrusion pattern according to a fifth embodiment of the present invention; and

[0021] FIG. 6 is a partial cutaway view of a vertically-aligned (VA) LCD according to one embodiment of the present invention.

DETAILED DESCRIPTION OF THE PREFERRED EMBODIMENT

[0022] The present invention provides a multi-domain vertically aligned (MVA) LCD having discontinuous regulating means for use in liquid crystal injecting process such as one drop fill (ODF) process. The LCD according to the present invention comprises a first substrate and a second substrate processed for vertical alignment and a liquid crystal being sandwiched between the first and second substrates. The discontinuous regulating means is provided on at least one of the first and second substrates. The liquid crystal layer includes liquid crystal molecules aligning in a direction generally perpendicular to a principal surface of said first substrate when no substantial electric field is applied to said liquid crystal layer. The discontinuous regulating means regulates orientation of the liquid crystal layer such that the liquid crystal molecules are aligned obliquely when a voltage is applied so that the orientation will include

a plurality of directions within each pixel thereby improving viewing angle performance. Since the regulating means is formed in a discontinuous pattern, air trapped between the first and second substrates can be easily vented through the regulating means, thereby significantly reducing the occurring rate of bubbles.

[0023] As shown in FIG. 6, the LCD mainly comprises a first substrate 102 and a second substrate 104. The surfaces of the substrates are processed for vertical alignment. A liquid crystal 130 having a negative dielectric constant anisotropy is sealed between the two substrates. The MVA LCD of the present invention is preferably a thin-film transistor LCD. Typically, the first substrate 102 is referred to as a color filter (CF) substrate because color filters 102a are formed, while the second substrate 104 is referred to as a TFT substrate. Usually, spacers (not shown) are formed between the substrates for defining a cell gap between the substrates.

[0024] FIGS. 1a and 1b show a portion of an MVA LCD 100 with discontinuous regulating means realized by providing specific protrusion and slit pattern according to a first embodiment of the present invention. The first substrate 102 has a light-shielding matrix 101 (not shown in FIG. 1b), for example a black matrix, formed thereon. The second substrate 104 is provided with a plurality of parallel gate lines 104a, a plurality of parallel data lines 104b perpendicular to the gate lines 104a, and a plurality of thin film transistors (TFTs) and pixel electrodes 120 (not shown in FIG. 1a) formed like a matrix at the intersections between the gate lines 104a and data lines 104b. The pixel electrode 120 has first edges 120a parallel to the gate lines 104a and second edges 120b parallel to the data lines 104b. The LCD 100 is formed with a plurality of protrusions 130 and slits 140 (not shown in FIG. 1a) for regulating the orientation of the liquid crystal such that the alignment of liquid crystal molecules is induced by application of a voltage to include a plurality of directions. By virtue of orientating the liquid crystal molecules into a plurality of mutually different directions, the viewing angle the LCD 100 can be greatly increased. The protrusions 130 are arranged in parallel to one another on the first substrate. Each protrusion 130 has a main body 130a being bent substantially in a zigzag pattern. The slits 140 are provided on the pixel electrodes 120. As shown in FIG. 1b, the slits 140 and the main bodies 130a of the protrusions are arranged alternately.

[0025] The protrusions 130 of the MVA LCD 100 have a plurality of breaks 130b such that air trapped between the protrusions 130 can be easily vented through the breaks 130b, thereby significantly reducing the occurring rate of bubbles. Furthermore, during the step of pressing the substrates in the ODF process, the breaks 130b of the protrusions 130 allows the dropped liquid crystal material to be spread more evenly such that the liquid crystal material will completely fill the cavity formed between the two substrates. However, since the pattern of the protrusions 130 is discontinuous, the tilting direction of the liquid crystal molecules due to the protrusions 130 becomes disordered at the edges of the breaks 130b. This results in disclination generating around the edges of the breaks 130b. Therefore, all of the breaks 130b may be designed to have a predetermined size in order to achieve good air ventilation while minimizing disclination. Alternatively, all of the breaks 130b may be formed within the area of the light-shielding matrix 101

thereby significantly masking the deteriorated display quality such as light leakage due to disclination.

[0026] As shown in FIG. 1a, the light-shielding matrix 101 has a plurality of rows 101a extending along the gate lines 104a and a plurality of columns 101b extending along the data lines 104b. All of the breaks 130b are designed to be located within the area of the rows 111a of the light-shielding matrix such that none of the protrusions 130 extends across the rows 101a. Alternatively, the protrusions of the present invention may have breaks 130c (see FIG. 5) all located within the area of the columns 101b of the light-shielding matrix such that none of the protrusions extends across the columns 101b of the light-shielding matrix. All of the breaks may be designed to be located within the area of the rows and the columns of the light-shielding matrix such that none of the protrusions extends across the rows and the columns of the light-shielding matrix.

[0027] Generally speaking, when the liquid crystal display is only provided with the slits 140 and the main bodies 130a of the protrusions bent in zigzag, some particular area within the pixel appear darkened. The change of the orientation of the liquid crystal in the darkening area turns to become slow in response to the voltage applied. This reduces the contrast and the response speed, thereby deteriorating the display quality. This is due to the fact that the inclination of liquid crystal molecules influenced by the electric field near the edges 120a, 120b of the pixel electrode 120 (see FIG. 1b) is considerably different from that caused by the slits 140 in the darkening area. Therefore, as shown in FIG. 1b, the protrusions 130 preferably have a plurality of first branches 130d formed at positions facing the first edges 120a of the pixel electrodes 120 and a plurality of second branches 130e formed at positions facing the second edges 120b of the pixel electrodes 120. In this embodiment, the difference between the directors (i.e., the average direction of the long axes of the liquid crystal molecules) of the liquid crystal molecules around the branches 130d, 130e and the slits 140 is significantly reduced down to at most 45 degrees. This significantly suppresses disclination occurring at the border between the domain formed by the edges of the pixel electrode 120 and the domain formed by the slits 140, thereby avoiding display defects due to the disclination.

[0028] FIG. 2 shows the pixel region of an MVALCD 200 according to a second embodiment of the present invention wherein the pixel electrodes 120 and the slits 140 are not shown. This LCD 200 includes a plurality of protrusions 132 formed inside one channel defined by two first branches 130d extending from the main bodies 130a of adjacent protrusions 130 and the substrates 102, 104 (not shown). During the step of pressing the substrates in the ODF process, the protrusions 132 slow down the flow rate of the dropped liquid crystal material through the aforementioned channel defined by the first branches 130d.

[0029] FIG. 3 shows the pixel region of an MVALCD 300 according to a third embodiment of the present invention wherein the pixel electrodes 120 and the slits 140 are not shown. This LCD 300 includes a plurality of protrusions 134 formed at a location close to the left opening of the aforementioned channel. During the step of pressing the substrates in the ODF process, the protrusions 134 slow down the flow rate of the dropped liquid crystal material through the aforementioned channel.

[0030] FIG. 4 shows the pixel region of an MVALCD 400 according to a fourth embodiment of the present invention wherein the pixel electrodes 120 and the slits 140 are not shown. This LCD 400 includes a plurality of protrusions 136 formed at a location close to the right opening of the aforementioned channel. During the step of pressing the substrates in the ODF process, the protrusions 136 slow down the flow rate of the dropped liquid crystal material through the aforementioned channel.

[0031] Next, the process for forming the aforementioned protrusions will be described as follows. A photoresist is coated on the surface thereof, transferred a predetermined pattern (referring to the protrusion pattern shown in FIGS. 1-5), and then developed to form the protrusions 130, 132, 134, 136. This process is easily carried out by using conventional techniques. Additionally, the slits 140 can be formed simultaneously with the pixel electrodes 120 by utilizing conventional process.

[0032] Although the invention has been explained in relation to its preferred embodiment, it is to be understood that many other possible modifications and variations can be made without departing from the spirit and scope of the invention as hereinafter claimed.

What is claimed is:

1. A liquid crystal display, comprising:

a first substrate and a second substrate processed for vertical alignment;

a liquid crystal being sandwiched between the first and second substrates, the liquid crystal layer including liquid crystal molecules aligning in a direction generally perpendicular to a principal surface of said first substrate when no substantial electric field is applied to said liquid crystal layer; and

discontinuous means provided on at least one of the first and second substrates for regulating orientation of the liquid crystal layer such that the liquid crystal molecules are aligned obliquely when a voltage is applied so that the orientation will include a plurality of directions.

2. The liquid crystal display as claimed in claim 1, wherein the first substrate is provided with a plurality of pixel electrodes, and the discontinuous means comprising:

an array of slits provided on the pixel electrodes; and

an array of first protrusions provided on the second substrate, each of the first protrusions having a main body being arranged substantially in a zigzag pattern and in parallel to one another,

wherein the slits and the main bodies of the first protrusions are arranged alternately, and each of the first protrusions has a plurality of breaks formed therein.

3. The liquid crystal display as claimed in claim 2, wherein the second substrate is provided with a light-shielding matrix and the breaks of the first protrusions are all formed within the area of the light-shielding matrix.

4. The liquid crystal display as claimed in claim 3, wherein:

the first substrate has a plurality of parallel gate lines and a plurality of parallel data lines perpendicular to the gate lines; and

the light-shielding matrix has a plurality of columns extending along the data lines and a plurality of rows extending along the gate lines,

wherein none of the first protrusions extends across the rows of the light-shielding matrix.

5. The liquid crystal display as claimed in claim 3, wherein:

the first substrate has a plurality of parallel gate lines and a plurality of parallel data lines perpendicular to the gate lines; and

the light-shielding matrix has a plurality of columns extending along the data lines and a plurality of rows extending along the gate lines,

wherein none of the first protrusions extends across the columns of the light-shielding matrix.

6. The liquid crystal display as claimed in claim 3, wherein:

the first substrate has a plurality of parallel gate lines and a plurality of parallel data lines perpendicular to the gate lines; and

the light-shielding matrix has a plurality of columns extending along the data lines and a plurality of rows extending along the gate lines,

wherein none of the first protrusions extends across the columns and the rows of the light-shielding matrix.

7. The liquid crystal display as claimed in claim 3, wherein:

the first substrate has a plurality of parallel gate lines and a plurality of parallel data lines perpendicular to the gate lines;

each pixel electrode has first edges parallel to the gate lines and second edges parallel to the data lines;

the first protrusions have a plurality of first branches formed at positions facing the first edges of the pixel electrodes and a plurality of second branches formed at positions facing the second edges of the pixel electrodes, and

the second substrate further comprises a plurality of second protrusions formed inside one channel defined by two first branches extending from the main bodies of adjacent first protrusions and the first and second substrates.

8. The liquid crystal display as claimed in claim 3, wherein:

the first substrate has a plurality of parallel gate lines and a plurality of parallel data lines perpendicular to the gate lines;

each pixel electrode has first edges parallel to the gate lines and second edges parallel to the data lines;

the first protrusions have a plurality of first branches formed at positions facing the first edges of the pixel electrodes and a plurality of second branches formed at positions facing the second edges of the pixel electrodes, and

the second substrate further comprises a plurality of third protrusions each formed at a location close to one

channel defined by two first branches extending from the main bodies of adjacent first protrusions and the first and second substrates.

9. A color filter substrate for use in forming a liquid crystal display with a thin film transistor substrate having a plurality of pixel electrodes and an array of slits provided on the pixel electrodes, the color filter substrate comprising:

an array of first protrusions each having a main body being arranged substantially in a zigzag pattern and in parallel to one another, the slits of the thin film transistor and the main bodies of the first protrusions being arranged alternately,

wherein each of the first protrusions has a plurality of breaks formed therein.

10. The color filter substrate as claimed in claim 9, further comprising a light-shielding matrix wherein the breaks of the first protrusions are all formed within the area of the light-shielding matrix.

11. The color filter substrate as claimed in claim 10, wherein:

the thin film transistor substrate has a plurality of parallel gate lines and a plurality of parallel data lines perpendicular to the gate lines; and

the light-shielding matrix has a plurality of columns extending along the data lines and a plurality of rows extending along the gate lines when the color filter substrate is disposed on the thin film transistor substrate,

wherein none of the first protrusions extends across the rows of the light-shielding matrix.

12. The color filter substrate as claimed in claim 10, wherein:

the thin film transistor substrate has a plurality of parallel gate lines and a plurality of parallel data lines perpendicular to the gate lines; and

the light-shielding matrix has a plurality of columns extending along the data lines and a plurality of rows extending along the gate lines when the color filter substrate is disposed on the thin film transistor substrate,

wherein none of the first protrusions extends across the columns of the light-shielding matrix.

13. The color filter substrate as claimed in claim 10, wherein:

the thin film transistor substrate has a plurality of parallel gate lines and a plurality of parallel data lines perpendicular to the gate lines; and

the light-shielding matrix has a plurality of columns extending along the data lines and a plurality of rows extending along the gate lines when the color filter substrate is disposed on the thin film transistor substrate,

wherein none of the first protrusions extends across the columns and the rows of the light-shielding matrix.

14. The color filter substrate as claimed in claim 10, wherein:

the thin film transistor has a plurality of parallel gate lines and a plurality of parallel data lines perpendicular to the gate lines;

each pixel electrode has first edges parallel to the gate lines and second edges parallel to the data lines;

the first protrusions have a plurality of first branches formed at positions facing the first edges of the pixel electrodes and a plurality of second branches formed at positions facing the second edges of the pixel electrodes when the color filter substrate is disposed on the thin film transistor substrate, and

the second substrate further comprises a plurality of second protrusions formed inside one channel defined by two first branches extending from the main bodies of adjacent first protrusions and the first and second substrates.

15. The color filter substrate as claimed in claim 10, wherein:

the thin film transistor has a plurality of parallel gate lines and a plurality of parallel data lines perpendicular to the gate lines;

each pixel electrode has first edges parallel to the gate lines and second edges parallel to the data lines;

the first protrusions have a plurality of first branches formed at positions facing the first edges of the pixel electrodes and a plurality of second branches formed at positions facing the second edges of the pixel electrodes when the color filter substrate is disposed on the thin film transistor substrate, and

the second substrate further comprises a plurality of third protrusions each formed at a location close to one channel defined by two first branches extending from the main bodies of adjacent first protrusions and the first and second substrates.

* * * * *

专利名称(译)	液晶显示器		
公开(公告)号	US20040075799A1	公开(公告)日	2004-04-22
申请号	US10/270496	申请日	2002-10-16
[标]申请(专利权)人(译)	群创光电股份有限公司		
申请(专利权)人(译)	奇美电子股份有限公司.		
当前申请(专利权)人(译)	群创光电		
[标]发明人	LIN BI LY		
发明人	LIN, BI LY		
IPC分类号	G02F1/1333 G02F1/139 G02F1/1337		
CPC分类号	G02F1/1393 G02F1/133707		
其他公开文献	US7133098		
外部链接	Espacenet USPTO		

摘要(译)

液晶显示器主要包括两个处理用于垂直对准的基板和一个密封在两个基板之间的具有负介电常数各向异性的液晶。在一个衬底上形成的像素电极上提供一排狭缝。在另一个基板上提供遮光基质和突起阵列。每个第一突起具有主体，主体基本上以Z字形图案布置并且彼此平行。第一突起的狭缝和主体交替排列。液晶显示器的特征在于，第一突起具有在遮光基质的区域内形成的多个断裂。

