



(19) **United States**

(12) **Patent Application Publication**

(10) **Pub. No.: US 2002/0109811 A1**

**Park et al.**

(43) **Pub. Date:**

**Aug. 15, 2002**

(54) **ARRAY SUBSTRATE FOR REFLECTIVE AND TRANSFLECTIVE LIQUID CRYSTAL DISPLAY DEVICES AND MANUFACTURING METHOD FOR THE SAME**

**Publication Classification**

(51) **Int. Cl.<sup>7</sup>** ..... **G02F 1/136**

(52) **U.S. Cl.** ..... **349/113**

(76) **Inventors:** **June-Ho Park**, Gyeongsangnam-do (KR); **Jae-Sik Choi**, Busan (KR)

Correspondence Address:  
**BIRCH STEWART KOLASCH & BIRCH**  
**PO BOX 747**  
**FALLS CHURCH, VA 22040-0747 (US)**

(57) **ABSTRACT**

An array substrate for a reflective liquid crystal display device, including a gate line and a data line defining a pixel region by crossing each other; a switching element at a crossing portion of the gate line and the data line; a first passivation layer covering the switching element and the data line; and formed of an inorganic insulating material; a reflective electrode on the first passivation layer, and connected to the switching element; and a second passivation layer on the reflective electrode. The second passivation layer being formed of an organic insulating material.

(21) **Appl. No.:** **10/028,759**

(22) **Filed:** **Dec. 28, 2001**

(30) **Foreign Application Priority Data**

Feb. 13, 2001 (KR) ..... 2001-7097

Jun. 1, 2001 (KR) ..... 2001-30699

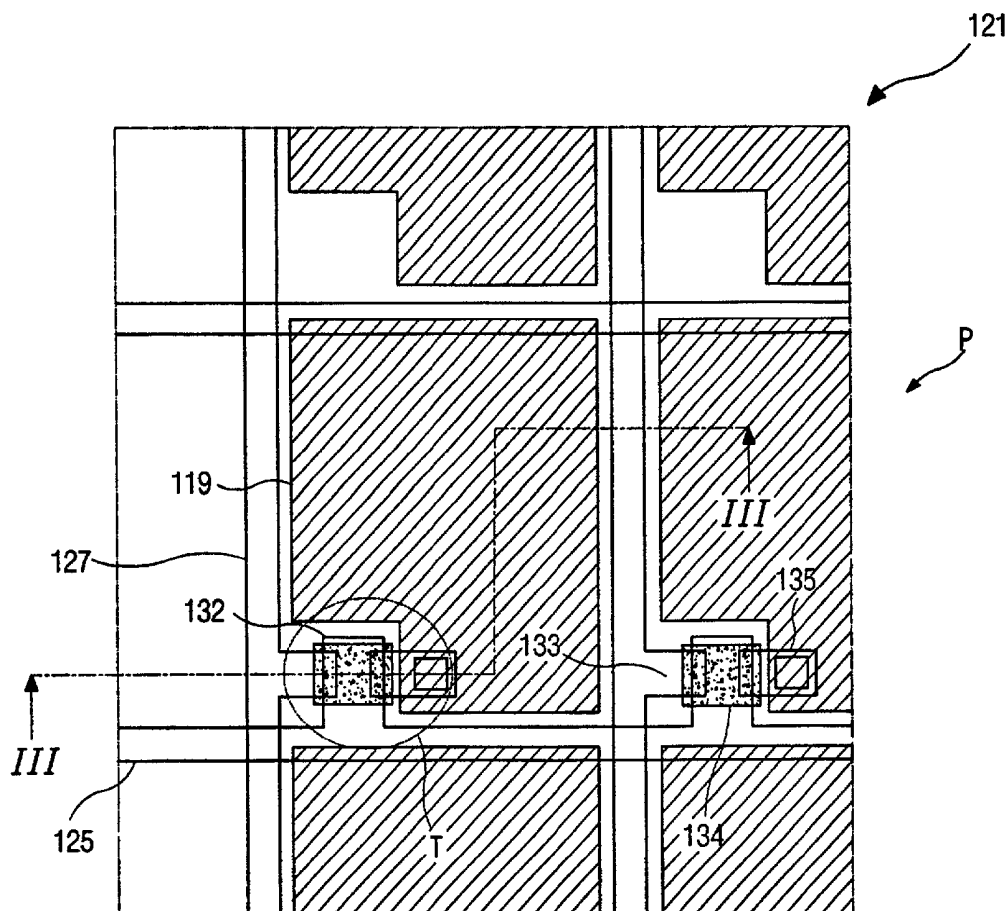

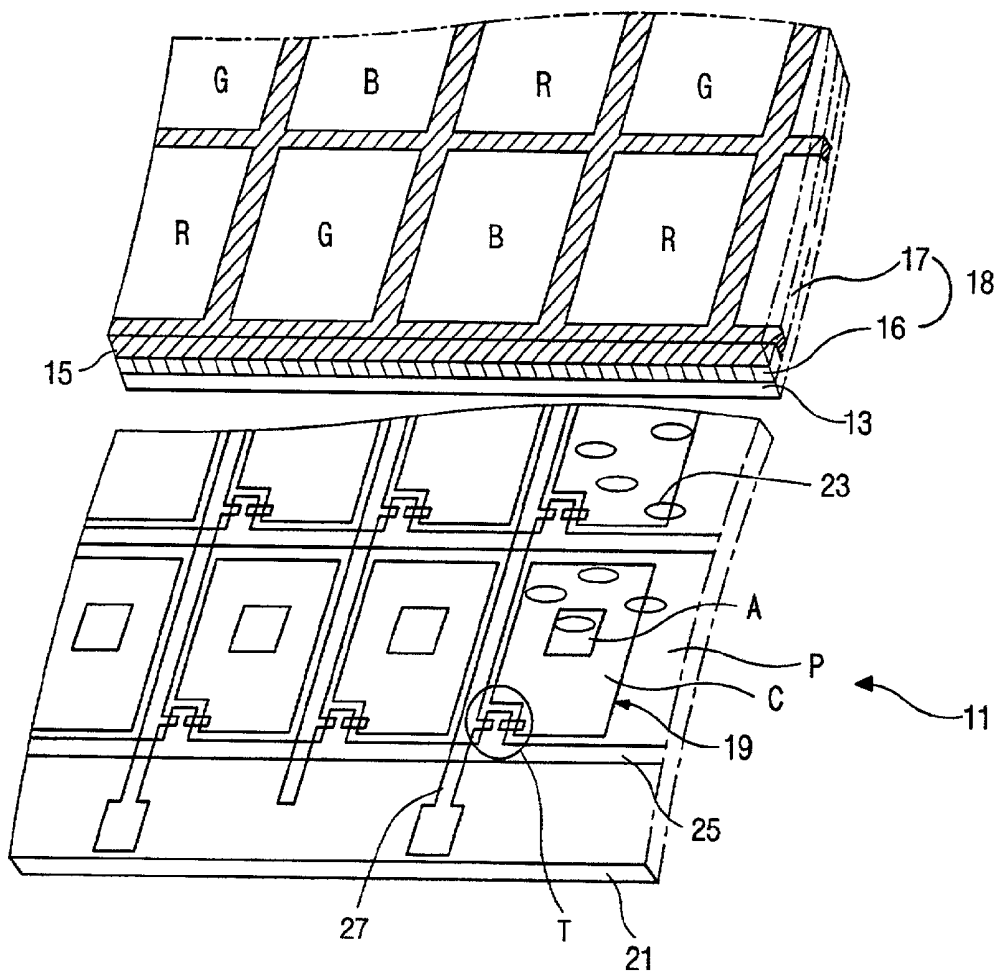

FIG. 1  
(CONVENTIONAL ART)

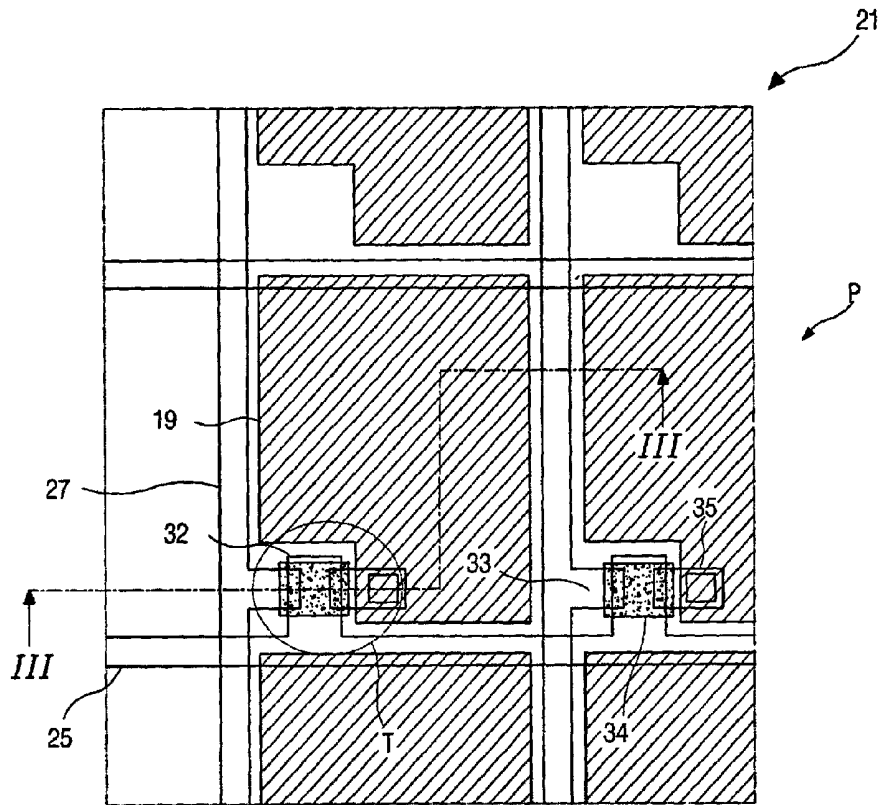

FIG. 2  
(CONVENTIONAL ART)

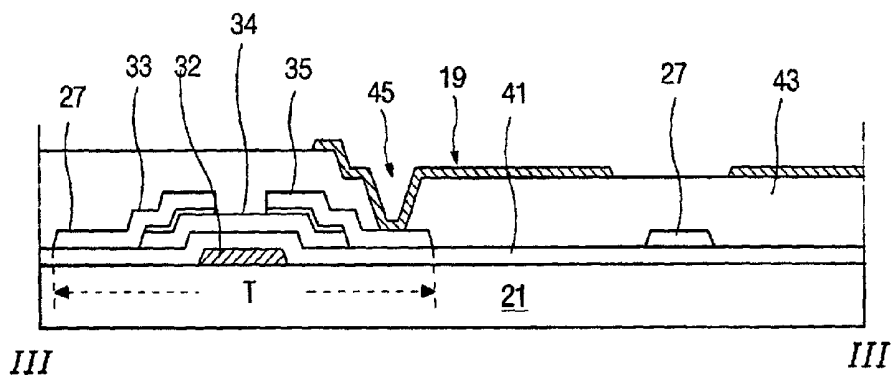

FIG. 3  
(CONVENTIONAL ART)

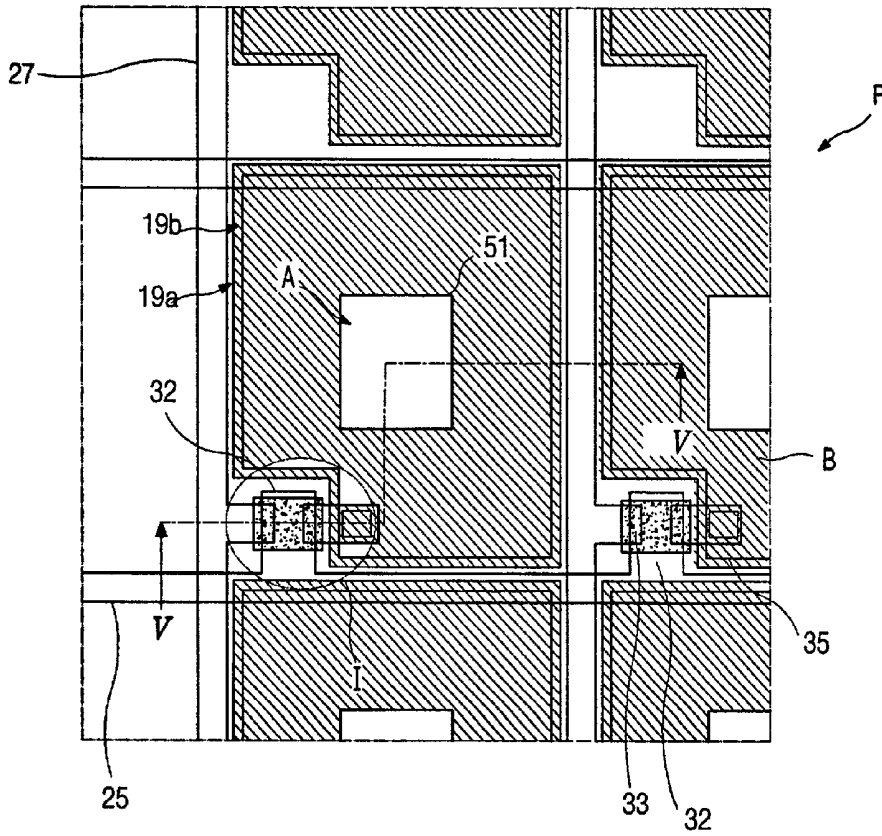

FIG. 4  
(CONVENTIONAL ART)

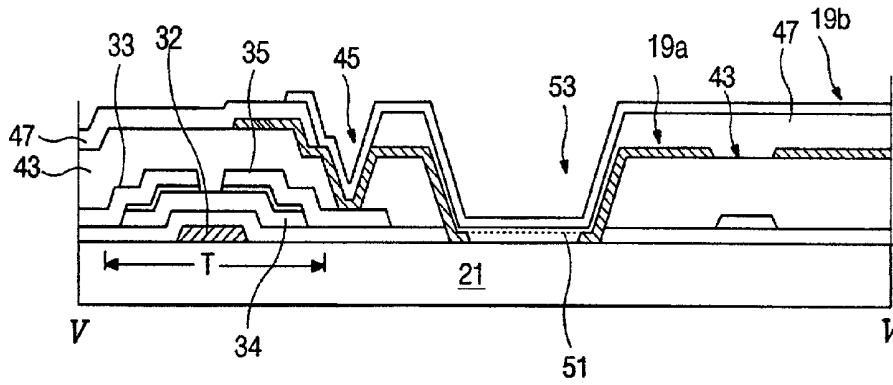

FIG. 5  
(CONVENTIONAL ART)

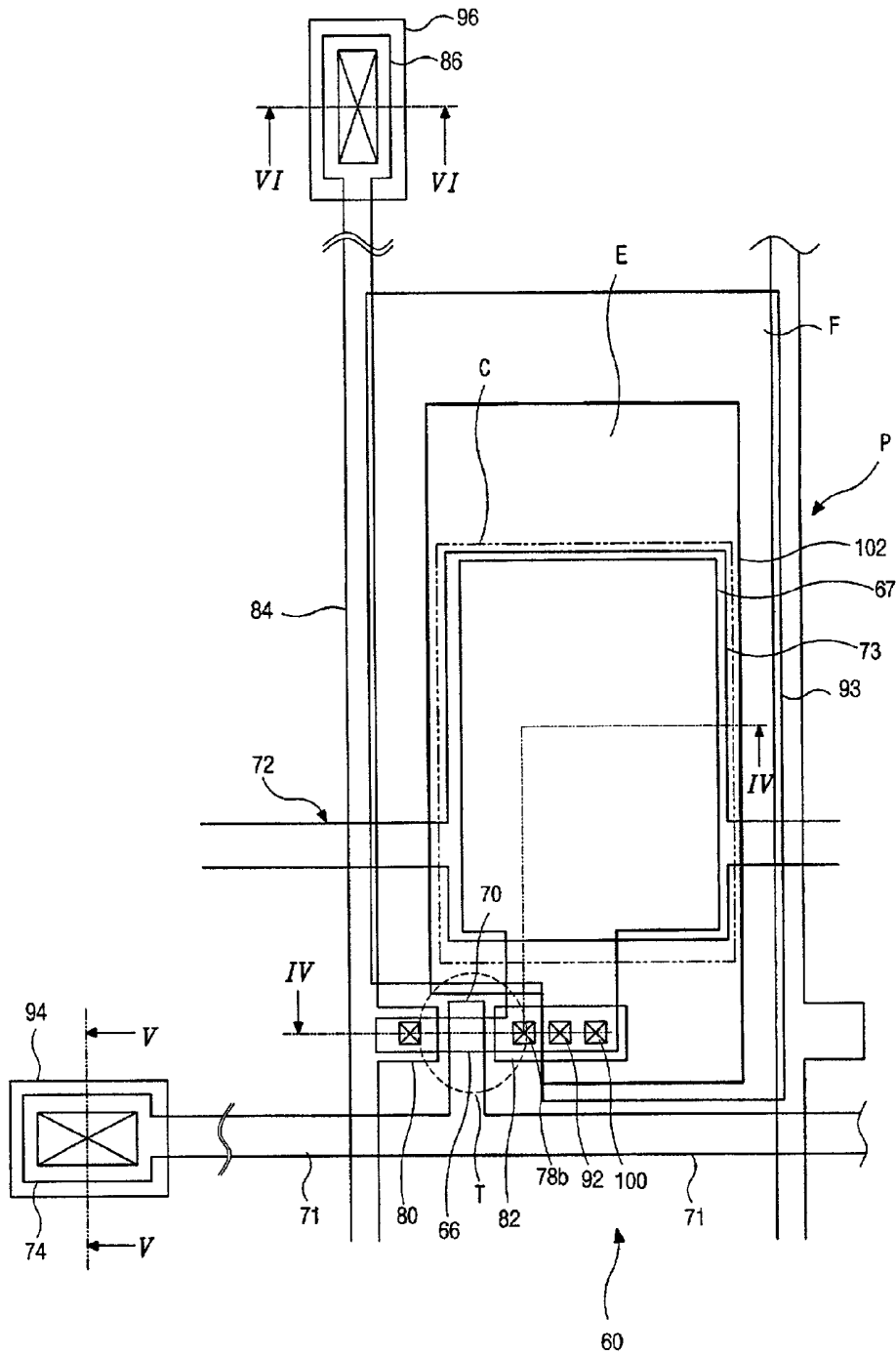

FIG. 6  
(CONVENTIONAL ART)

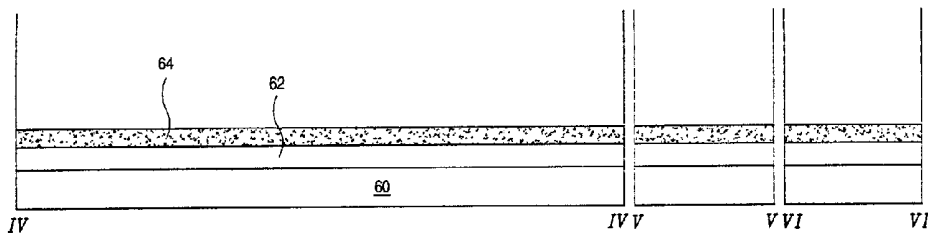

FIG. 7A  
(CONVENTIONAL ART)

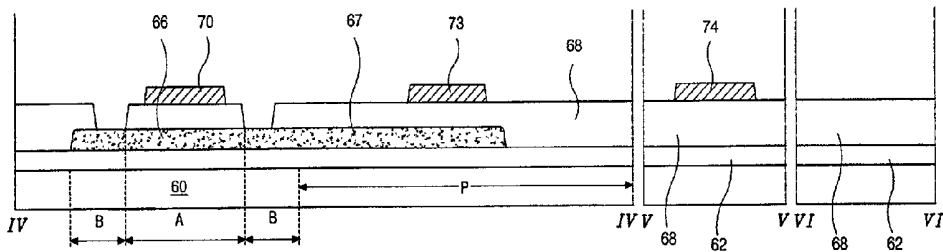

FIG. 7B  
(CONVENTIONAL ART)

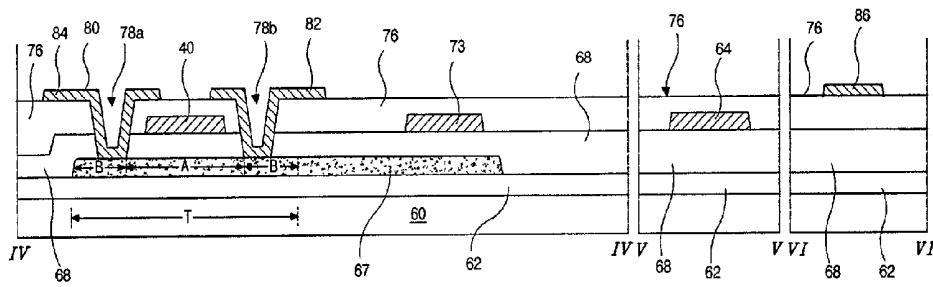

FIG. 7C  
(CONVENTIONAL ART)



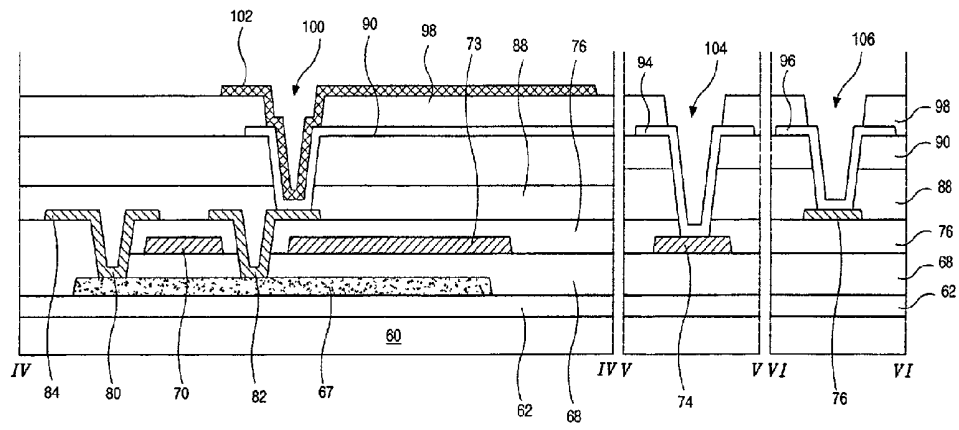

FIG. 7F  
(CONVENTIONAL ART)



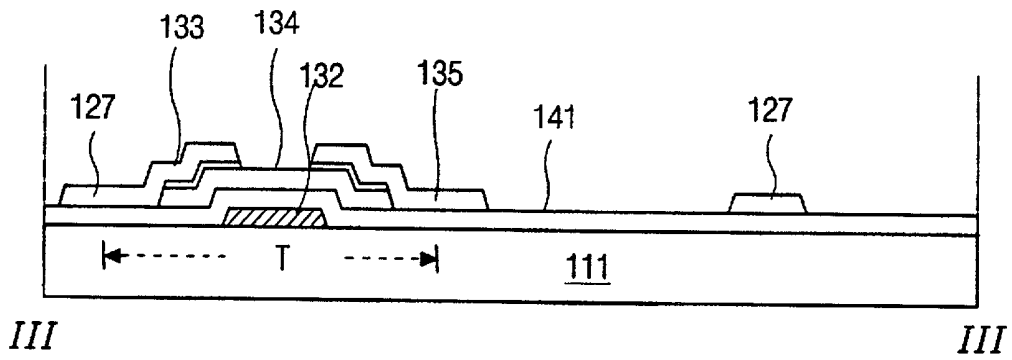

FIG. 9A

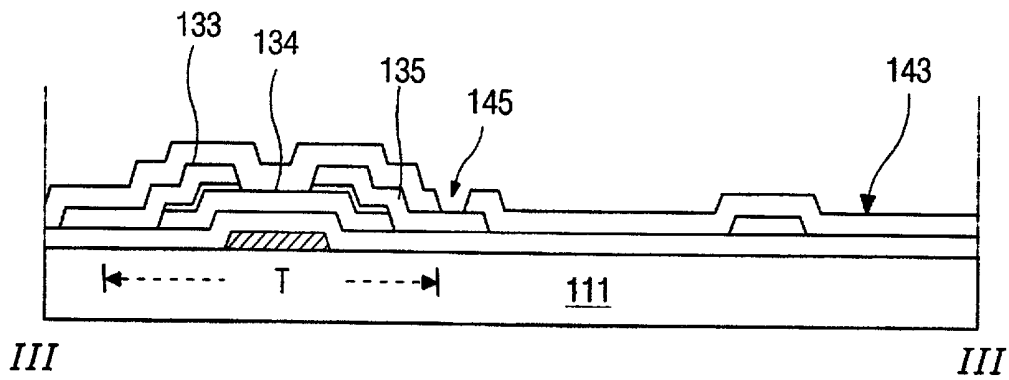

FIG. 9B

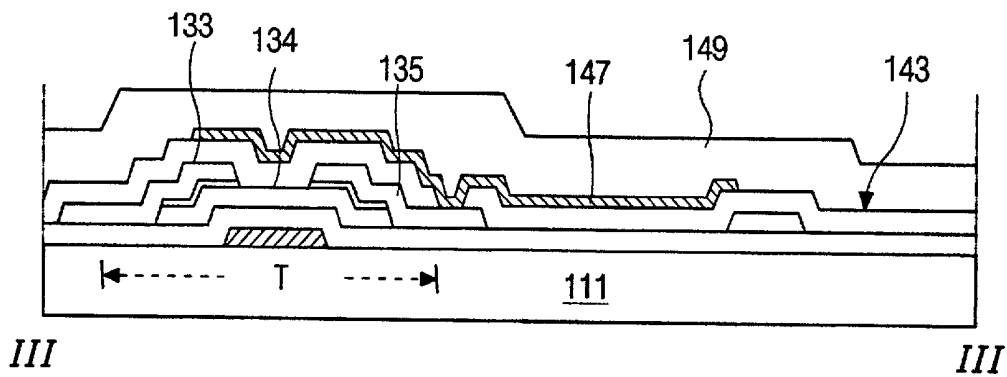

FIG. 9C



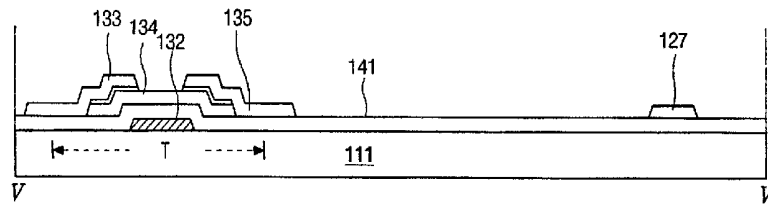

FIG. 11A

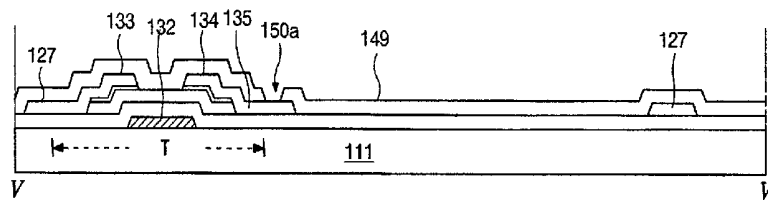

FIG. 11B

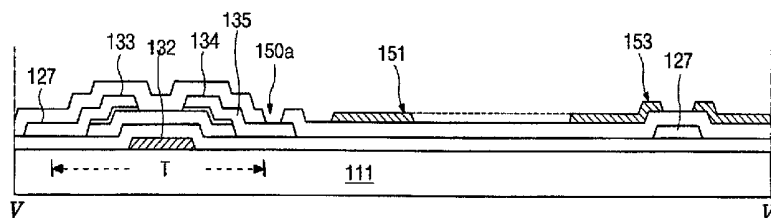

FIG. 11C

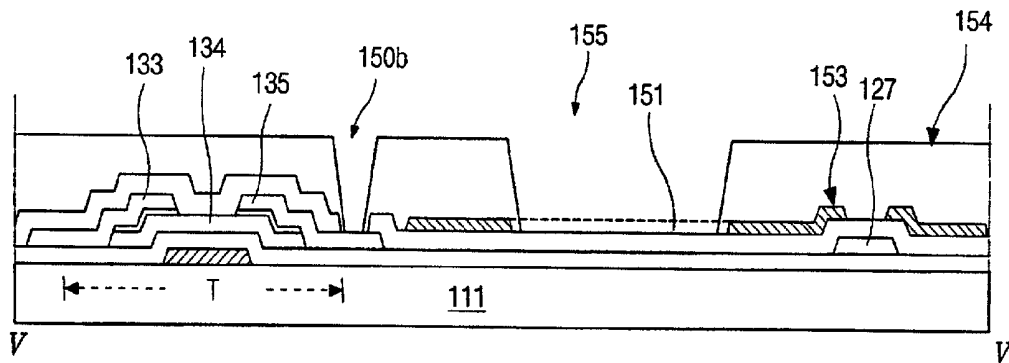

FIG. 11D

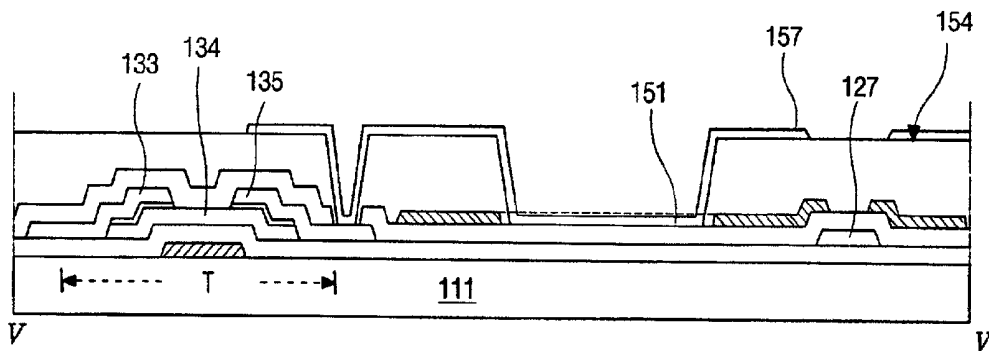

FIG. 11E



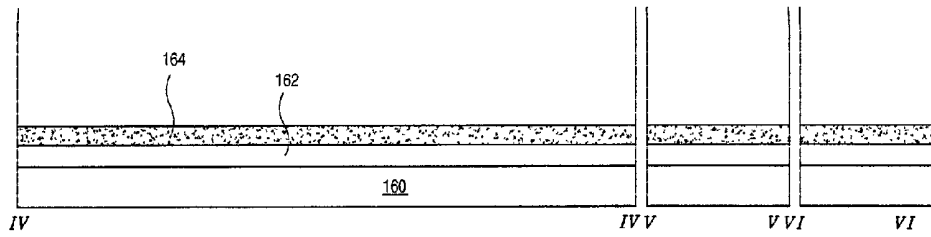

FIG. 13A

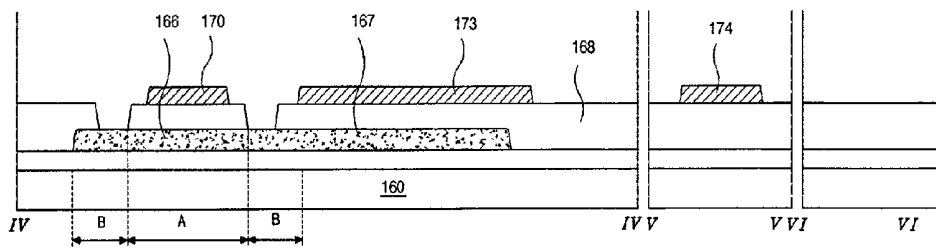

FIG. 13B

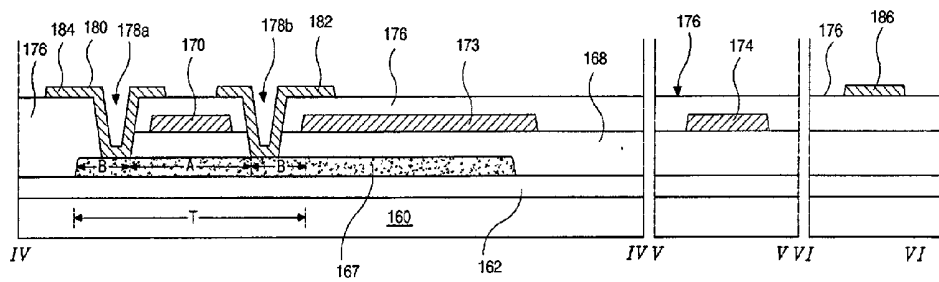

FIG. 13C

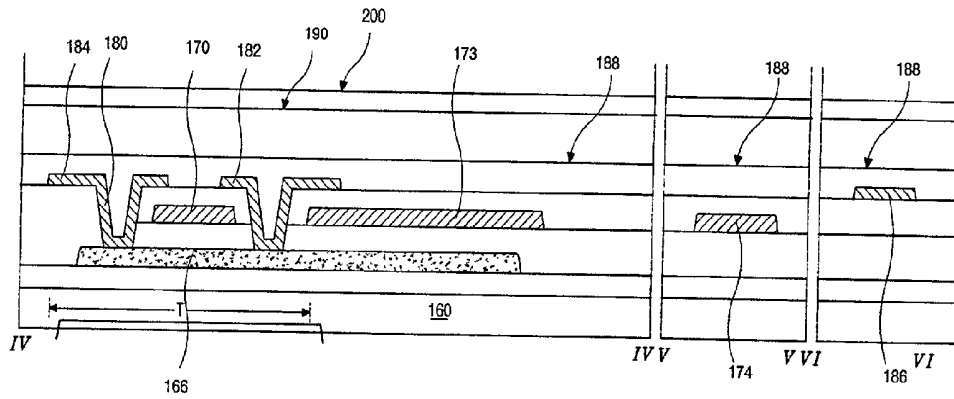

FIG. 13D

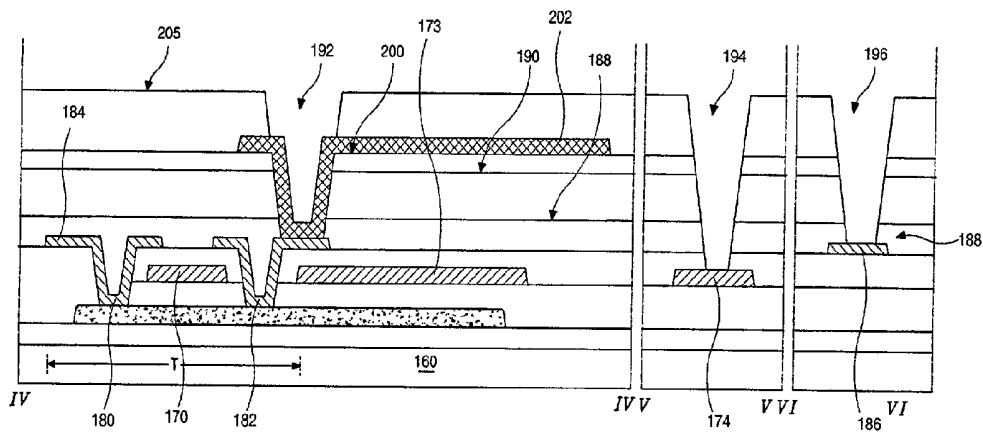

FIG. 13E

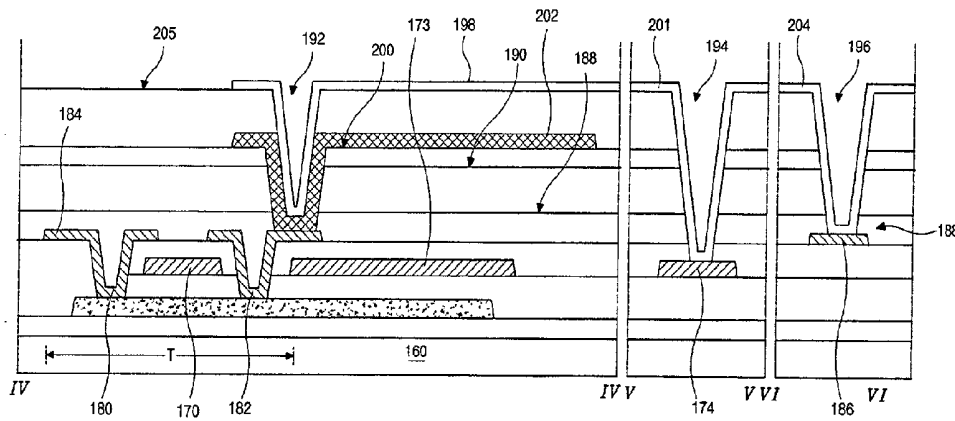

FIG. 13F

**ARRAY SUBSTRATE FOR REFLECTIVE AND  
TRANSFLECTIVE LIQUID CRYSTAL DISPLAY  
DEVICES AND MANUFACTURING METHOD FOR  
THE SAME**

BACKGROUND OF THE INVENTION

[0001] 1. Field of the Invention

[0002] The present invention relates to liquid crystal display devices, and more particularly, to an array substrate for reflective and transflective liquid crystal display devices.

[0003] 2. Description of the Background Art

[0004] Generally, a reflective liquid crystal display device does not need to equip an additional light source such as a back light because it can substitute an external light source for the back light. A transflective liquid crystal display device has both properties of the reflective liquid crystal display device and a transmissive liquid crystal display device. Because the transflective liquid crystal display device utilizes both of the back light and the external light source, it can save power consumption.

[0005] FIG. 1 illustrates a liquid crystal panel for a conventional transflective liquid crystal display device. The conventional transflective liquid crystal display device 11 has an upper substrate 15 that includes a color filter 18 a transparent common electrode 13 and a lower substrate 21 that includes a pixel region "P", a pixel electrode 19, thin film transistor and an array of gate lines 25 and data lines 27. The color filter 18 includes a black matrix 16 and sub-color filters R, G and B. The pixel electrode 19 has a transmission portion "A" and a reflection portion "C". Liquid crystal 23 is interposed between the upper substrate 15 and the lower substrate 21. The lower substrate 21 is also referred to as an array substrate with thin film transistors "T", switching elements, arranged in a matrix on the array substrate 21. A plurality of horizontal gate lines 25 and a plurality of vertical data lines 27 cross each other defining the pixel region "P". If the transparent pixel electrode 19 and the transmission portion "A" are omitted from the transflective liquid crystal display device, it becomes a reflective liquid crystal display device.

[0006] FIG. 2 is a plan view illustrating a partial array substrate for a conventional reflective liquid crystal display device. As shown in the figure, a plurality of gate lines 25 and a plurality of data lines 27 cross each other defining a pixel region "P". A thin film transistor "T" is formed at a crossing portion of the gate line 25 and the data line 27. The thin film transistor "T" usually includes a gate electrode 32, a source electrode 33, a drain electrode 35 and an active layer 34. A pixel electrode 19 is formed in the pixel region "P" and the thin film transistor "T" connected to the drain electrode 35 drives the liquid crystal 23 of FIG. 1. A reflective electrode, which is formed of opaque conductive metal having a high reflexivity, is substituted for the pixel electrode 19 in the reflective liquid crystal display device. The opaque conductive metal is selected from a group consisting of aluminum (Al) and aluminum alloys (AlNd, for example), for example.

[0007] Because the reflective liquid crystal display device uses an external light source, incident light from the external light source passes through the upper substrate (not shown) and is then reflected at the reflective electrode 10 on the

array substrate 21. The reflected light subsequently passes through the liquid crystal and thereby polarization properties of the light are changed according to birefringence properties of the liquid crystal. Color images can be displayed when the light passing through the liquid crystal colors the color filter.

[0008] FIG. 3 is a cross-sectional view taken along III-III of FIG. 2 according to the conventional art. As shown in the figure, a gate electrode 32 and a gate line 25 of FIG. 2 are formed on a substrate 21. A gate insulating layer 41 is formed on the substrate 21 and on the gate electrode 32. An active layer 34 is formed on the gate insulating layer 41 and partially overlapped with a source electrode 33 and a drain electrode 35. The source electrode 33, the drain electrode 35 and the data line 27 are formed on the active layer 34. A thin film transistor includes the gate electrode 32, the source electrode 33, the drain electrode 35 and the active layer 34. A passivation layer 43 made of insulating material is formed on the thin film transistor. The passivation layer 43 is subsequently patterned to form a drain contact hole 45 exposing a part of the drain electrode 35. A reflective electrode 19 contacts the drain electrode 35 through the drain contact hole 45. The material for the reflective electrode 19 is selected from a group including aluminum (Al) and aluminum alloy (AlNd, for example), etc.

[0009] FIG. 5 is a cross-sectional view taken along line V-V of FIG. 4 according to the conventional art. A thin film transistor "T" including a gate electrode 32, a source electrode 33, a drain electrode 35 and an active layer 34 is formed and a first passivation layer 43 is formed on the thin film transistor "T". The first passivation layer 43 is formed by depositing a transparent organic insulating material such as benzocyclobutene (BCB) and acrylic resin. A drain contact hole 45 that exposes a part of the drain electrode 35 is formed and an etching hole 53 is formed by etching the first passivation layer 43 corresponding to the transmission hole 53 in the pixel region "P". A reflective electrode 19a that contacts the drain electrode 35 through the drain contact hole 45 is formed in the pixel region "P". The reflective electrode 19a is formed of aluminum (Al) and aluminum alloys (AlNd, for example), etc. A second passivation layer 47 is formed on the reflective electrode 19a and patterned to expose the reflective electrode 19a corresponding to the drain contact hole 45. The second passivation layer 47 is formed of insulating material such as silicon oxide (SiO<sub>2</sub>) or silicon nitride (SiN<sub>x</sub>), for example. A transparent pixel electrode 19b that contacts the exposed reflective electrode 19a through the patterned second passivation layer 47 is formed on the second passivation layer 47.

[0010] Several masks for patterning array elements of the array substrate are used in the manufacturing of the conventional reflective and transflective liquid crystal display device. An align key for accurate aligning of the mask and the substrate is formed on the corner of the substrate simultaneously with the gate line or the data line forming process. The shape of the align key has unevenness. Accordingly, a detector aligns the mask and the substrate by irradiating light onto the uneven surface of the align key and sensing the light reflected from the surface of the align key.

[0011] FIG. 6 is a plan view illustrating a partial array substrate having a coplanar type polysilicon thin film transistor for a conventional transflective liquid crystal display

device. A gate line **71** and a data line **84** cross each other defining a pixel region "P" and a thin film transistor "T" is formed at a crossing portion of the gate line **71** and the data line **84**. The thin film transistor "T" is a polysilicon thin film transistor that includes a polysilicon active layer and has a coplanar structure in which a gate electrode **70** is formed under a source electrode **80** and a drain electrode **82**. A gate pad **74** and a data pad **86**, which receive an external signal, are formed respectively at one end of the gate line **71** and the data line **84**. The gate pad **74** and the data pad **86** respectively contact a gate pad terminal **94** and a data pad terminal **96** that are formed of transparent conductive material. The thin film transistor "T" includes the gate electrode **70**, the source electrode **80**, the drain electrode **82** and an active layer **66**. The active layer **66** has an active layer expanded portion **67** in the pixel region "P". A storage line **72** is formed parallel to the gate line **71** with a same material as that of the gate line **71** and has a storage line expanded portion **73** in the pixel region "P". The pixel electrode **63** contacts the drain electrode **82**. A storage capacitor portion "C" and a reflection portion "E" are formed in the pixel region "P". A reflector **102** is formed on the storage capacitor portion "C". The rest portion of the pixel region "P" except the reflector **102** is a transmission portion "F".

[0012] FIGS. 7A to 7F are cross-sectional views taken along IV-IV, V-V, VI-VI of FIG. 6 illustrating a fabricating sequence of an array substrate according to the related art. In FIG. 7A, a first insulating layer **62** is formed on a substrate **60** by depositing inorganic insulating material such as silicon oxide (SiO<sub>2</sub>) or silicon nitride (SiN<sub>x</sub>) and an amorphous silicon layer **64** is formed on the first insulating layer by depositing amorphous silicon (a-Si:H). The first insulating layer **62**, referred to as a buffer layer, is for preventing an expansion of alkaline substances from the substrate **60**. The amorphous silicon layer **64** is crystallized into polysilicon by introducing a solid phase crystallization (SPC) method, a metal induced crystallization (MIC) method, a laser annealing method and a field effect metal induced crystallization (FEMIC) method.

[0013] In FIG. 7B, a semi-conductor layer **66** is formed by patterning the crystallized layer and a gate insulating layer **68**, a second insulating layer, is formed on the semi-conductor layer **66**. A conductive metal layer is subsequently formed on the gate insulating layer **68**. A gate electrode **70** and a gate line **71** of FIG. 6 are formed by patterning the deposited conductive metal layer. The semi-conductor layer **66** has a semiconductor layer expanded portion **67** in the pixel region "P". The gate pad **74** is formed at one end of the gate line **71**. The storage line **72** is simultaneously formed parallel to the gate line **71** and the storage line **72** has the storage line expanded portion **73** on the pixel region "P".

[0014] The semi-conductor layer **66** can be divided into two regions, one is a first active region "A" and the other is a second active region "B". The first active region "A" is a pure silicon region and the second active region "B" is an impure silicon region. The second active regions "B" are positioned at both sides of the first active region "A". The gate insulating layer **68** and the gate electrode **70** are formed on the first active region "A". After forming of the gate electrode **70**, ion doping is performed onto the second active region "B" to form a resistant contact layer. The gate electrode **70** serves as an ion stopper that prevents dopants from penetrating into the first active region "A". After the

ion doping is finished, the semi-conductor layer **66**, the polysilicon island, implements a specific electric characteristic, which varies with types of the dopants. If the dopant is, for example, B<sub>2</sub>H<sub>6</sub> that includes a Group III element, a doped portion of the polysilicon island **66** becomes a p-type semiconductor. Whereas, if the dopant is PH<sub>3</sub> that includes a Group VI element, the doped portion of the polysilicon island **66** becomes an n-type semiconductor. A proper dopant should be selected to satisfy the use of a device. After the dopant is applied onto the polysilicon island **66**, the dopant is activated.

[0015] In FIG. 7C, a third insulating layer **76**, i.e., an interlayer insulator, is formed over the whole area of the substrate **60** and is patterned to form a source contact hole **78a** and a drain contact hole **78b**. A source electrode **80** and a drain electrode **82**, which contact the second active region "B" through the source contact hole **78a** and the drain contact hole **78b**, respectively, are formed by depositing and then patterning conductive metals such as aluminum (Al), aluminum alloys, tungsten (W), copper (Cu), chromium (Cr) and molybdenum (Mo), etc. A data line **84** that contacts the source electrode **80** is simultaneously formed and a data pad **86** is formed at one end of the data line **84**. The polysilicon thin film transistor "T" is formed through the above processes.

[0016] In FIG. 7D, a fourth insulating layer **88** is formed on the whole area of the substrate **60** and then the thin film transistor undergoes a hydrogenation process. The hydrogenation process is for removing defects that occurred on the surface of the active layer **66**. A fifth insulating layer **90** is formed on the fourth insulating layer **88** using transparent organic insulating material such as benzocyclobutene (BCB) or acrylic resin. A first drain contact hole **92** exposing the drain electrode **82**, a gate pad contact hole **91** exposing the gate pad **74** and a data pad contact hole **95** exposing the data pad **86** are formed by patterning simultaneously the laminated layers.

[0017] In FIG. 7E, a pixel electrode **93** that contacts the exposed drain electrode **82** and is extended to the pixel region, a gate pad terminal **94** that contacts the exposed gate pad and a data pad terminal **96** that contacts the exposed data pad are formed on the fifth insulating layer **90** using transparent conductive material such as indium tin oxide (ITO) or indium zinc oxide (IZO), for example.

[0018] In FIG. 7F, a sixth insulating layer **98** is formed on the whole area of the substrate **60** using silicon oxide (SiO<sub>2</sub>) or silicon nitride (SiN<sub>x</sub>), for example. A second drain contact hole **100** that exposes the pixel electrode **93** contacting the drain electrode **82** is formed by patterning the sixth insulating layer **98**. A reflective electrode **102**, which contacts the exposed pixel electrode **93**, is formed on the sixth insulating layer **98** using conductive metal such as aluminum (Al) or aluminum alloys, for example. A first etching hole **104** that exposes the gate pad terminal **94** and a second etching hole **106** that exposes the data pad terminal **96** are formed by patterning the sixth insulating layer **98**. The reason for exposing the gate pad terminal **94** and the data pad terminal **96** in the last process is to prevent the pixel electrode **93** and the reflective electrode **102** from being etched together in etching solution during an etching process for the reflective electrode **102**.

[0019] Conventional reflective or transmissive liquid crystal display devices have some problems described as fol-

lows. First, because a reflective electrode is formed on an organic insulating layer such as benzocyclobutene (BCB) and the contact property of the reflective electrode and the benzocyclobutene (BCB) layer is not good, the reflective electrode may not be stably deposited on the organic insulating layer. This lack of stability lowers electric properties of a liquid crystal panel. Second, when a sputtering process is used for forming the reflective electrode on the benzocyclobutene (BCB), accelerated electrons collide into the surface of the benzocyclobutene (BCB) and separate the benzocyclobutene (BCB) particles from the surface, which produces benzocyclobutene (BCB) particles in a deposition chamber. The benzocyclobutene (BCB) particles in the deposition chamber contaminate the deposition chamber. Lastly, an align key may not be detected by a detecting apparatus if the benzocyclobutene (BCB) is deposited on the substrate and covers the align key. Accordingly, alignment error of a mask and the substrate may be occurred during a light exposing process for patterning the reflective electrode.

#### SUMMARY OF THE INVENTION

[0020] Accordingly, the present invention is directed to an array substrate for reflective and transreflective liquid crystal display devices and a manufacturing method of the array substrate for reflective and transreflective liquid crystal display devices that substantially obviates one or more of problems due to limitations and disadvantages of the related art.

[0021] An object of the present invention is to provide an array substrate for a reflective liquid crystal display device, wherein a reflective electrode is not formed on organic insulating material such as benzocyclobutene (BCB), but formed on inorganic insulating material such as silicon nitride ( $\text{SiN}_x$ ) to improve contact property of the reflective electrode and to prevent a deposition chamber from being contaminated with particles of the organic insulating material.

[0022] Another object of the present invention is to provide a manufacturing method of an array substrate for a reflective liquid crystal display device.

[0023] Another object of the present invention is to provide an array substrate for a transreflective liquid crystal display device, wherein a reflective electrode is not formed on organic insulating material such as benzocyclobutene (BCB), but formed on inorganic insulating material such as silicon nitride ( $\text{SiN}_x$ ) to improve contact property of the reflective electrode and to prevent a deposition chamber from being contaminated with particles of the organic insulating material.

[0024] Another object of the present invention is to provide a manufacturing method of an array substrate for a transreflective liquid crystal display device.

[0025] Another object of the present invention is to provide an array substrate for a transreflective liquid crystal display device having a barrier layer between an organic insulating layer and a reflector to improve contact property of the reflective electrode and to prevent a deposition chamber from being contaminated with particles of the organic insulating material.

[0026] Another object of the present invention is to provide a manufacturing method of an array substrate for a

transreflective liquid crystal display device having a barrier layer between an organic insulating layer and a reflector.

[0027] To achieve these and other advantages, one embodiment of the present invention, an array substrate for a reflective liquid crystal display device includes a gate line and a data line defining a pixel region by crossing each other, a switching element at a crossing portion of the gate line and the data line, a first passivation layer covering the switching element and the data line, the first passivation layer being formed of inorganic insulating material, a reflective electrode on the first passivation layer, the reflective electrode being connected to the switching element, and a second passivation layer on the reflective electrode, the second passivation layer being formed of organic insulating material. The reflective electrode is formed of conductive metal material such as aluminum (Al) or aluminum alloys, for example. The switching element is a thin film transistor including a gate electrode, a source electrode, a drain electrode and an active layer. The first passivation layer is desirably formed of silicon nitride ( $\text{SiN}_x$ ). The second passivation layer is formed of organic insulating material such as benzocyclobutene (BCB) or acrylic resin, for example.

[0028] In another aspect, a preferred embodiment of a manufacturing method of an array substrate for a reflective liquid crystal display device includes the steps of forming a gate line and a data line that define a pixel region by crossing each other; forming a switching element at a crossing portion of the gate line and the data line; forming a first passivation layer covering the switching element and the data line; the first passivation layer being formed of inorganic insulating material; forming a reflective electrode on the first passivation layer, the reflective electrode being connected to the switching element; and, forming a second passivation layer on the reflective electrode. The second passivation layer being formed of organic insulating material.

[0029] The reflective electrode may be formed of conductive metal material such as aluminum (Al) or aluminum alloys, for example. The switching element is a thin film transistor including a gate electrode, a source electrode, a drain electrode and an active layer. The first passivation layer is preferably formed of silicon nitride ( $\text{SiN}_x$ ). The second passivation layer is formed of organic insulating material such as benzocyclobutene (BCB) or acrylic resin, for example.

[0030] In another embodiment, an array substrate for a transreflective liquid crystal display device includes a gate line and a data line defining a pixel region by crossing each other; a switching element at a crossing portion of the gate line and the data line; a first passivation layer covering the switching element and the data line and being formed of inorganic insulating material; a reflective electrode on the first passivation layer, connected to the switching element and including a transmission hole; a second passivation layer on the reflective electrode, formed of organic insulating material and patterned to expose a part of the switching element; and a transparent pixel electrode on the second passivation layer, formed in the pixel region and contacting the exposed part of the switching element.

[0031] The reflective electrode is formed of conductive metal material such as aluminum (Al) or aluminum alloys,

for example. The switching element is a thin film transistor including a gate electrode, a source electrode, a drain electrode and an active layer. The first passivation layer is desirably formed of silicon nitride ( $\text{SiN}_x$ ). The second passivation layer is formed of organic insulating material such as benzocyclobutene (BCB) or acrylic resin, for example.

[0032] In another embodiment, a manufacturing method of an array substrate for a transfective liquid crystal display device includes the steps of forming a gate line and a data line defining a pixel region by crossing each other; forming a switching element at a crossing portion of the gate line and the data line; forming a first passivation layer covering the switching element and the data line, the first passivation layer being formed of inorganic insulating material; forming a reflective electrode on the first passivation layer, the reflective electrode being connected to the switching element and including a transmission hole; forming a second passivation layer on the reflective electrode, the second passivation layer being formed of organic insulating material and patterned to expose a part of the switching element; and forming a transparent pixel electrode on the second passivation layer. The pixel electrode being formed in the pixel region and contacting the exposed part of the switching element. The reflective electrode is formed of conductive metal material such as aluminum (Al) or aluminum alloys, for example. The switching element is a thin film transistor including a gate electrode, a source electrode, a drain electrode and an active layer. The first passivation layer is desirably formed of silicon nitride ( $\text{SiN}_x$ ). The second passivation layer is formed of organic insulating material such as benzocyclobutene (BCB) or acrylic resin, for example.

[0033] In another embodiment, an array substrate for a transfective liquid crystal display device includes a thin film transistor including an active layer a gate electrode and source and drain electrodes, being formed on a substrate in sequence; a gate line including a gate pad at one end of it, the gate line being connected to the gate electrode; a storage line being formed parallel to the gate line and being spaced apart from the gate line; a data line defining a pixel region by crossing the gate line, including a data pad at one end of it and being connected to the source electrode; an organic insulating layer over the thin film transistor and the data line; a barrier layer on the organic insulating layer and formed of inorganic insulating material; a reflector on the barrier layer, and a transparent pixel electrode on an inorganic insulating layer. The pixel electrode contacting the drain electrode, and the inorganic insulating layer being formed between the reflector and the pixel electrode. The array substrate for a transfective liquid crystal display device may further include a buffer layer beneath the active layer using inorganic insulating material such as silicon oxide ( $\text{SiO}_2$ ) or silicon nitride ( $\text{SiN}_x$ ), for example. The active layer is formed of polysilicon. The storage line is desirably formed with a same material as that of the gate line on a same layer as that of the gate line. The reflector is formed of conductive metal material such as aluminum (Al) or aluminum alloys, for example. The pixel electrode is formed of transparent conductive material such as indium tin oxide (ITO) or indium zinc oxide (IZO), for example. The reflector may desirably be extended to the data line and simultaneously cover the thin film transistor. The reflector may be partially overlapped with the gate line and the gate line. The barrier

layer is formed using inorganic insulating material such as silicon oxide ( $\text{SiO}_2$ ) or silicon nitride ( $\text{SiN}_x$ ), for example. The array substrate further may include an insulating layer beneath the organic insulating layer to perform a hydrogenation process of the thin film transistor. The barrier layer is desirably formed of silicon nitride ( $\text{SiN}_x$ ).

[0034] In another embodiment, a manufacturing method of an array substrate for a transfective liquid crystal display device includes the steps of forming a thin film transistor including an active layer, a first insulating layer, a gate electrode, a second insulating layer being formed on a substrate in sequence; forming a gate line and a storage line such that, the gate line includes a gate pad at one end of it and being connected to the gate electrode; and the storage line is formed parallel to the gate line and spaced apart from the gate line; forming a data line defining a pixel region by crossing the gate line including a data pad at one end of it and being connected to the source electrode, forming a third insulating layer over the thin film transistor and the data line, the third insulating layer being formed of transparent organic insulating material; forming a fourth insulating layer on the third insulating layer, the third insulating layer being a barrier layer and being formed of inorganic insulating material; forming a reflector on the barrier layer; forming a drain contact hole over the drain electrode by depositing and patterning a fifth insulating layer on the reflector; and forming a transparent pixel electrode on an inorganic insulating layer, the pixel electrode contacting the drain electrode. The inorganic insulating layer being formed between the reflector and the pixel electrode. The array substrate for a transfective liquid crystal display device may further include a buffer layer beneath the active layer using inorganic insulating material such as silicon oxide ( $\text{SiO}_2$ ) or silicon nitride ( $\text{SiN}_x$ ), for example. The active layer is formed of polysilicon. The storage line is desirably formed with a same material as that of the gate line on a same layer as that of the gate line. The reflector is formed of conductive metal material such as aluminum (Al) or aluminum alloys, for example. The pixel electrode is formed of transparent conductive material such as indium tin oxide (ITO) or indium zinc oxide (IZO). The reflector may desirably be extended to the data line and cover the thin film transistor. The reflector may be partially overlapped with the gate line and the gate line. The barrier layer is formed using inorganic insulating material such as silicon oxide ( $\text{SiO}_2$ ) or silicon nitride ( $\text{SiN}_x$ ), for example. The manufacturing method of the array substrate according to the present invention further includes forming an insulating layer beneath the organic insulating layer to perform a hydrogenation process of the thin film transistor. The barrier layer is desirably formed of silicon nitride ( $\text{SiN}_x$ ).

[0035] These and other objects of the present application will become more readily apparent from the detailed description given hereinafter. However, it should be understood that the detailed description and specific examples, while indicating preferred embodiments of the invention, are given by way of illustration only, since various changes and modifications within the spirit and scope of the invention will become apparent to those skilled in the art from this detailed description.

#### BRIEF DESCRIPTION OF THE DRAWINGS

[0036] The present invention will become more fully understood from the detailed description given hereinbelow

and the accompanying drawings which are given by way of illustration only, and thus are not limitative of the present invention and wherein:

[0037] FIG. 1 is an exploded perspective view illustrating a liquid crystal panel for a conventional transmissive liquid crystal display device;

[0038] FIG. 2 is a plan view illustrating a partial array substrate for a conventional reflective liquid crystal display device;

[0039] FIG. 3 is a cross-sectional view taken along line III-III of FIG. 2 according to the conventional art;

[0040] FIG. 4 is a plan view illustrating a partial array substrate having an inverted stagger type thin film transistor for a conventional transmissive liquid crystal display device;

[0041] FIG. 5 is a cross-sectional view taken along line V-V of FIG. 4 according to the conventional art;

[0042] FIG. 6 is a plan view illustrating a partial array substrate having a coplanar type polysilicon thin film transistor for a conventional transmissive liquid crystal display device;

[0043] FIGS. 7A to 7F are cross-sectional views taken along lines IV-IV, V-V, VI-VI of FIG. 6 illustrating a fabricating sequence of an array substrate according to the conventional art;

[0044] FIG. 8 is a plan view illustrating a partial array substrate for a reflective liquid crystal display device according to a first embodiment of the present invention;

[0045] FIGS. 9A to 9C are cross-sectional views taken along III-III of FIG. 8 illustrating a method of manufacturing an array substrate according to the first embodiment of the present invention;

[0046] FIG. 10 is a plan view illustrating a partial array substrate having an inverted stagger type thin film transistor for a transmissive liquid crystal display device according to a second embodiment of the present invention;

[0047] FIGS. 11A to 11E are cross-sectional views taken along line V-V of FIG. 10 illustrating a fabricating sequence of an array substrate according to the second embodiment of the present invention;

[0048] FIG. 12 is a plan view illustrating a partial array substrate having a coplanar type polysilicon thin film transistor for a transmissive liquid crystal display device according to a third embodiment of the present invention; and

[0049] FIGS. 13A to 13F are cross-sectional views taken along lines IV-IV, V-V, VI-VI of FIG. 12 illustrating a fabricating sequence of an array substrate according to the third embodiment of the present invention.

#### DETAILED DESCRIPTION OF THE PREFERRED EMBODIMENTS

[0050] Reference will now be made in detail to the preferred embodiment of the present invention, which is illustrated in the accompanying drawings.

[0051] A first embodiment of the present invention will be described hereinafter with reference to FIG. 8 and FIGS. 9A to 9C. FIG. 8 is a plan view illustrating a partial array substrate for a reflective liquid crystal display device accord-

ing to the first embodiment of the present invention. FIGS. 9A to 9C are cross-sectional views taken along III-III of FIG. 8 illustrating a fabricating sequence of an array substrate according to the first embodiment of the present invention. In FIG. 9A, a gate line 125 and a gate electrode 132 are formed on the substrate 111 by depositing conductive metal such as aluminum (Al), aluminum alloys, molybdenum (Mo), copper (Cu), tungsten (W) and chromium (Cr), for example, and patterning it. If the gate electrode 132 and the gate line 125 are formed of aluminum (Al), an additional conductive metal layer for protecting the gate electrode 132 and the gate line 125 may be formed. A gate insulating layer 141 is formed on the substrate 111 and on the gate electrode 132 by depositing or coating organic insulating material or inorganic insulating material. The organic insulating material for the gate insulating layer 141 is selected from a group including benzocyclobutene (BCB) and acrylic resin. The inorganic insulating material for the gate insulating layer 141 is selected from a group including silicon oxide ( $\text{SiO}_2$ ) and silicon nitride ( $\text{SiN}_x$ ). A semi-conductor layer 134 is formed on the gate insulating layer 141 by depositing an amorphous silicon layer and impure amorphous silicon layer on the gate insulating layer 141 and patterning it. A data line 127 crossing the gate line 125, a source electrode 133 connected to the data line 127 and a drain electrode 135 being spaced apart from the source electrode 133 are formed by depositing conductive metal material on the whole area of the substrate 111 and patterning it. Though it is not shown in the figure, an align key is formed on the corner of the substrate 111 during the gate line 125 of FIG. 8 forming process or the data line 127 forming process.

[0052] In FIG. 9B, a first passivation layer 143 is formed on the substrate by depositing an inorganic insulating material such as silicon oxide ( $\text{SiO}_2$ ) or silicon nitride ( $\text{SiN}_x$ ) and then patterning it to form a drain contact hole 145 exposing a part of the drain electrode 135. The first passivation layer 143 is formed thin. As a result, it can be formed thin on the align key allowing an uneven shape of the align key be remained.

[0053] In FIG. 9C, a reflective electrode 147 that contacts the drain electrode 135 through the drain contact hole 145 is formed on the first passivation layer 143 by depositing and patterning a conductive metal material such as aluminum (Al) or aluminum alloys that has a low electric resistance and high reflexivity. At this time, a detection of the align key can be performed well during the depositing and etching process for the reflective electrode 147. Accordingly, a process error caused by an alignment error of the mask and the substrate does not occur during the reflective electrode forming process. A second passivation layer 149 is formed on the substrate 111 by depositing organic insulating material.

[0054] If silicon nitride ( $\text{SiN}_x$ ) is formed beneath the reflective electrode 147, the electrical conduction property of the liquid crystal panel can be improved and contact property between the reflective electrode 147 and the first passivation layer 143 can be improved, which results in an improvement of electric properties of a liquid crystal panel.

[0055] A second embodiment of the present invention will be described hereinafter with reference to FIG. 10 and FIGS. 11A to 11E. FIG. 10 is a plan view illustrating a partial array substrate having an inverted stagger type thin

film transistor for a transmissive liquid crystal display device according to the second embodiment of the present invention. FIGS. 11A to 11E are cross-sectional views taken along line V-V of FIG. 10 illustrating a fabricating sequence of an array substrate according to the second embodiment of the present invention. In FIG. 11A, because a thin film transistor forming process is the same as that of the first embodiment, i.e., a reflective liquid crystal display device, it will not be described in detail herein.

[0056] As shown in FIG. 11A, a gate electrode 132, a source electrode 133, a drain electrode 135, an active layer 134 and a data line 127 are formed on a substrate 111 in sequence. Though it is not shown in the Figures, an align key for accurate aligning of the mask and the substrate is formed on the corner of the substrate simultaneously with the gate line or the data line forming process. The shape of the align key is uneven. Accordingly, a detector aligns the mask and the substrate by irradiating light onto the uneven surface of the align key and sensing the light reflected from the surface of the align key.

[0057] In FIG. 11B, a first passivation layer 149 is formed on the substrate 111 and on the thin film transistor "T" by depositing inorganic insulating material such as silicon nitride ( $\text{SiN}_x$ ), for example, on the substrate 111. Because the first passivation layer 149 is formed thin on the substrate 111 compared with organic insulating material such as benzocyclobutene (BCB), for example, the uneven shape of the align key may remain. A first drain contact hole 150a for exposing a part of the drain electrode 135 is formed by patterning the first passivation layer 149.

[0058] In FIG. 11C, a reflector 153 that includes a transmission hole 151 in the pixel region is formed by depositing and patterning a metal such as aluminum (Al) and aluminum alloys, for example, on the first passivation layer 149. At this time, a detection of the align key can be achieved well during the depositing and etching process for the reflector 153. Accordingly, a process error caused by an alignment error of the mask and the substrate is not occurred during the reflective electrode forming process.

[0059] In FIG. 11D, a second passivation layer 154 is formed on the substrate 111 by depositing transparent organic insulating material such as benzocyclobutene (BCB) and acrylic resin. A second drain contact hole 150b that exposes a part of the drain electrode 135 is formed by etching the second passivation layer 154 corresponding to the first drain contact hole 150a of FIG. 11C and an etching hole 155 is formed by etching the second passivation layer 154 corresponding to the transmission hole 151. At this time, the first passivation layer 149 may be etched simultaneously with the second passivation layer 154.

[0060] In FIG. 11E, a transparent pixel electrode 157 that contacts the drain electrode 135 through the drain contact hole is formed by depositing and patterning transparent conductive material such as indium tin oxide (ITO) or indium zinc oxide (IZO), for example, on the second passivation layer 154.

[0061] Whereas the drain electrode is exposed by etching the first passivation layer 149 and the second passivation layer 154 respectively in a different process as in FIG. 11B and FIG. 11D, the drain contact hole can be formed by etching the first passivation layer 149 and the second passivation layer 154, simultaneously in a single process.

[0062] A third embodiment of the present invention will be described hereinafter with reference to FIG. 12 and FIGS. 13A to 13F. FIG. 12 is a plan view illustrating a partial array substrate having a coplanar type polysilicon thin film transistor for a transmissive liquid crystal display device according to the third embodiment of the present invention. FIGS. 13A to 13F are cross-sectional views taken along lines IV-IV, V-V and VI-VI of FIG. 12 illustrating a fabricating sequence of an array substrate according to the third embodiment of the present invention.

[0063] In FIG. 13A, a first insulating layer 162, i.e., a buffer layer, is formed on the transparent insulating substrate 160 by depositing inorganic insulating material such as silicon oxide ( $\text{SiO}_2$ ) or silicon nitride ( $\text{SiN}_x$ ). The buffer layer 162 is optional. A polysilicon layer 164 is formed by depositing amorphous silicon (a-Si:H) on the buffer layer 162 and crystallizing the amorphous silicon.

[0064] In FIG. 13B, a semi-conductor layer 166 is formed by patterning the polysilicon layer 164. The semi-conductor layer 166 has a semi-conductor layer expanded portion 167 corresponding to a pixel region "P" of FIG. 12. The semi-conductor layer 166 can be divided into a first active region "A" that serves as an active channel and a second active region "B" that is ion doped. A second insulating layer 168, i.e., a gate insulating layer, is formed on the substrate 160 and on the semi-conductor layer 166 by depositing inorganic insulating material such as silicon oxide ( $\text{SiO}_2$ ) or silicon nitride ( $\text{SiN}_x$ ), for example, on the substrate 160. A gate electrode 170 over the first active region "A", a gate line 171 connected to the gate electrode 170 and a gate pad 174 connected to one end of the gate line 171 are formed by depositing and patterning conductive metal material on the second insulating layer 168. A storage line 172 is simultaneously formed parallel to the gate line 171 and the storage line 171 has a storage line expanded portion 173.

[0065] In FIG. 13C, a third insulating layer 176, i.e., interlayer insulating layer, is formed by depositing insulating material on the whole area of the substrate 160. A first contact hole 178a and a second contact hole 178b, which expose the second active region "B" of the semi-conductor layer 167 are formed. A source electrode 180 and a drain electrode 182, which contact the exposed second active region "B" are formed by depositing and patterning conductive metal such as aluminum (Al), aluminum alloys, chromium (Cr), tungsten (W), molybdenum (Mo) and niobium (Nb), for example, on the third insulating layer 176. A data line 184, which is connected to the source electrode 180 and vertically extended from the source electrode 180 is formed on the third insulating layer 176. A data pad is formed at one end of the data line 184. The data line 184 defines a pixel region "P" by crossing the gate line 171. A polysilicon thin film transistor is formed through the above processes.

[0066] In FIG. 13D, a fourth insulating layer 188 is formed by depositing inorganic insulating material such as silicon oxide ( $\text{SiO}_2$ ) or silicon nitride ( $\text{SiN}_x$ ), for example, on the substrate 160. The thin film transistor then undergoes a hydrogenation process. The hydrogenation process is for removing defects occurred on the surface of the active layer 166 and the fourth insulating layer 188 may be formed of silicon nitride ( $\text{SiN}_x$ ) that includes hydrogen. A fifth insulating layer 190 is formed by depositing transparent organic

insulating material such as benzocyclobutene (BCB) or acrylic resin, for example, on the fourth insulating layer 188. A sixth insulating layer 200, i.e., a barrier layer, is formed by depositing inorganic insulating material such as silicon oxide ( $\text{SiO}_2$ ) or silicon nitride ( $\text{SiN}_x$ ), for example, on the fifth insulating layer 190.

[0067] In FIG. 13E, a reflector 202 is formed in the pixel region "P" by depositing and patterning conductive metal material such as aluminum (Al) or aluminum alloys, for example, on the barrier layer 200. As shown in the figure, the reflector 202 is formed over the storage line expanded portion 173. However, the reflector 202 may be formed over the thin film transistor and extended to cover the gate line 171 and the data line 184. The reflector and the storage line expansion portion 173 constitute a reflection portion "E" of FIG. 12 in the pixel region "P" of FIG. 12 and the remaining portion of the pixel region "P" of FIG. 12 is a transmission portion "F" of FIG. 12. Accordingly, an area ratio between the reflection portion and the transmission portion can be controlled by varying the reflector 202 and the storage line expansion portion 173. A seventh insulating layer 205 is formed by depositing inorganic insulating material such as silicon oxide ( $\text{SiO}_2$ ) or silicon nitride ( $\text{SiN}_x$ ), for example, on the substrate 130 and on the reflector 202. A drain contact hole 192 that exposes a part of the drain electrode 182 is formed by etching the fourth insulating layer 188, the fifth insulating layer 190, the sixth insulating layer 200, i.e., the barrier layer and the seventh insulating layer 205 over the drain electrode 182. A gate pad contact hole 194 that exposes the gate pad 174 is formed by etching laminated insulating layers from the third insulating layer 176 to the seventh insulating layer 205 over the gate pad 174. A data pad contact hole 196 that exposes the data pad is formed by etching laminated layers from the fourth insulating layer 188 to the seventh insulating layer 205 over the data pad 186.

[0068] An under-cut and an inversed taper, which occurs in the wall of the plurality of the contact holes can be prevented by equalizing an etching speed of the transparent organic insulating layers with the etching speed of the plurality of inorganic insulating layers. The equalizing of the etching speeds of the laminated layers is performed by adding about 65~80% of oxygen gas to etching gas ( $\text{SF}_6$ ,  $\text{CF}_4$ ).

[0069] In FIG. 13F, a pixel electrode 198 contacts the exposed drain electrode 182 through the drain contact hole 192. A gate pad terminal 201 contacts the gate pad 174 through the gate pad contact hole 194. A data pad terminal 204 contacts the data pad 186 through the data pad contact hole 196. The pixel electrode 198, gate pad terminal 201 and data pad terminal 204 are formed by depositing and patterning transparent conductive metal material such as indium tin oxide (ITO) or indium zinc oxide (IZO), for example, on the seventh insulating layer 205 and in the respective contact holes 192, 194 and 196.

[0070] The transfective liquid crystal display device of the present invention having a high aperture ratio can be manufactured through the manufacturing process described above.

[0071] As described above, an array substrate for reflective and transfective liquid crystal display devices includes a reflective electrode that avoids being formed directly on an organic insulating layer such as benzocyclobutene (BCB) by

exchanging a forming order of the organic insulating layer and an inorganic insulating layer such as silicon nitride ( $\text{SiN}_x$ ) or by introducing a barrier layer between the organic insulating layer and the reflective electrode. Accordingly, the array substrate with reflective electrode formed in this matter avoids the problems of the conventional art discussed above.

[0072] The invention being thus described, it will be obvious that the same may be varied in many ways. Such variations are not to be regarded as a departure from the spirit and scope of the invention, and all such modifications as would be obvious to one skilled in the art are intended to be included within the scope of the following claims.

What is claimed is:

1. An array substrate for a reflective liquid crystal display device, the substrate comprising:

a gate line and a data line defining a pixel region by crossing each other;

a switching element at a crossing portion of the gate line and the data line;

a first passivation layer covering the switching element and the data line, the first passivation layer being formed of an inorganic insulating material;

a reflective electrode on the first passivation layer, the reflective electrode being connected to the switching element; and

a second passivation layer on the reflective electrode, the second passivation layer being formed of an organic insulating material.

2. The device according to claim 1, wherein

the reflective electrode includes conductive metal material such as aluminum (Al) or aluminum alloys.

3. The device according to claim 1, wherein

the switching element is a thin film transistor including a gate electrode, a source electrode, a drain electrode and an active layer.

4. The device according to claim 1, wherein

the first passivation layer includes silicon nitride ( $\text{SiN}_x$ ).

5. The device according to claim 1, wherein

the second passivation layer is an organic insulating material including benzocyclobutene (BCB) or an acrylic resin.

6. A manufacturing method of an array substrate for a reflective liquid crystal display device, the method comprising the steps of:

forming a gate line and a data line such that the gate line and data line define a pixel region by crossing each other;

forming a switching element at a crossing portion of the gate line and the data line;

forming a first passivation layer covering the switching element and the data line, the first passivation layer being formed of an inorganic insulating material;

forming a reflective electrode on the first passivation layer, the reflective electrode being connected to the switching element; and

- forming a second passivation layer on the reflective electrode, the second passivation layer being formed of an organic insulating material.
- 7.** The method according to claim 6, wherein the reflective electrode is formed of conductive metal material including aluminum (Al) or an aluminum alloys.
- 8.** The method according to claim 6, wherein the switching element is a thin film transistor including a gate electrode, a source electrode, a drain electrode and an active layer.
- 9.** The method according to claim 6, wherein the first passivation layer is formed of silicon nitride ( $\text{SiN}_x$ ).
- 10.** The method according to claim 6, wherein the second passivation layer is formed of an organic insulating material including benzocyclobutene (BCB) or an acrylic resin.
- 11.** An array substrate for a transfective liquid crystal display device, the substrate comprising;
- a gate line and a data line defining a pixel region by crossing each other;
  - a switching element at a crossing portion of the gate line and the data line;
  - a first passivation layer covering the switching element and the data line, the first passivation layer being formed of an inorganic insulating material;
  - a reflective electrode on the first passivation layer, the reflective electrode being connected to the switching element and including a transmission hole;
  - a second passivation layer on the reflective electrode, the second passivation layer being formed of organic insulating material and patterned to expose a part of the switching element; and
  - a transparent pixel electrode on the second passivation layer, the pixel electrode being formed in the pixel region and contacting the exposed part of the switching element.
- 12.** The device according to claim 11, wherein the reflective electrode is formed of a conductive metal material including aluminum (Al) or aluminum alloys.
- 13.** The device according to claim 11, wherein the switching element is a thin film transistor including a gate electrode, a source electrode, a drain electrode and an active layer.
- 14.** The device according to claim 11, wherein the first passivation layer is formed of silicon nitride ( $\text{SiN}_x$ ).
- 15.** The device according to claim 11, wherein the second passivation layer is formed of an organic insulating material including benzocyclobutene (BCB) or an acrylic resin.
- 16.** A manufacturing method of an array substrate for a transfective liquid crystal display device, the method comprising the steps of:
- forming a gate line and a data line defining a pixel region by crossing each other;
  - forming a switching element at a crossing portion of the gate line and the data line;
  - forming a first passivation layer covering the switching element and the data line, the first passivation layer being formed of an inorganic insulating material;
  - forming a reflective electrode on the first passivation layer, the reflective electrode being connected to the switching element and including a transmission hole;
  - forming a second passivation layer on the reflective electrode, the second passivation layer being formed of an organic insulating material and patterned to expose a part of the switching element; and
  - forming a transparent pixel electrode on the second passivation layer, the pixel electrode being formed in the pixel region and contacting the exposed part of the switching element.
- 17.** The method according to claim 16, wherein the reflective electrode is formed of a conductive metal material including aluminum (Al) or an aluminum alloy.
- 18.** The method according to claim 16, wherein the switching element is a thin film transistor including a gate electrode, a source electrode, a drain electrode and an active layer.
- 19.** The method according to claim 16, wherein the first passivation layer is formed of silicon nitride ( $\text{SiN}_x$ ).
- 20.** The method according to claim 16, wherein the second passivation layer is formed of an organic insulating material including benzocyclobutene (BCB) or acrylic resin.
- 21.** An array substrate for a transfective liquid crystal display device, the substrate comprising;
- a thin film transistor including an active layer, a gate electrode and source and drain electrodes, formed sequentially on a substrate;
  - a gate line including connected to the gate electrode;
  - a gate pad at a first end of the gate line;
  - a storage line parallel to the gate line and spaced apart from the gate line;
  - a data line defining a pixel region by crossing the gate line, the data line being connected to the source electrode;
  - a data pad at one end of the data line;
  - an organic insulating layer over the thin film transistor and the data line;
  - a barrier layer on the organic insulating layer, the barrier layer being formed of an inorganic insulating material;
  - a reflector on the barrier layer;
  - an inorganic insulating layer between the reflector and the pixel electrode; and
  - a transparent pixel electrode on the inorganic insulating layer, the pixel electrode contacting the drain electrode.

**22.** The substrate according to claim 21, further comprising:

an insulating layer beneath the organic insulating layer for performing a hydrogenation process of the thin film transistor.

**23.** The substrate according to claim 21, further comprising:

a buffer layer beneath the active layer, the buffer layer including an inorganic insulating material such as silicon oxide ( $\text{SiO}_2$ ) or silicon nitride ( $\text{SiN}_x$ ).

**24.** The substrate according to claim 21, wherein

the active layer is formed of polysilicon.

**25.** The substrate according to claim 21, wherein

the storage line and gate line are formed of a same material and on a same layer.

**26.** The substrate according to claim 21, wherein

the reflector is formed of a conductive metal material including aluminum (Al) or an aluminum alloys.

**27.** The substrate according to claim 21, wherein

the pixel electrode is formed of a transparent conductive material including indium tin oxide (ITO) or indium zinc oxide (IZO).

**28.** The substrate according to claim 21, wherein

the reflector extends to the data line and covers the thin film transistor.

**29.** The substrate according to claim 21, wherein

the reflector is partially overlapped with the gate line or the data line.

**30.** The substrate according to claim 21, wherein

the reflector covers the thin film transistor.

**31.** The substrate according to claim 21, wherein

the barrier layer is formed using inorganic insulating material including silicon oxide ( $\text{SiO}_2$ ) or silicon nitride ( $\text{SiN}_x$ ), for example.

**32.** A method of forming an array substrate for a transmissive liquid crystal display device, the method comprising the steps of:

forming a thin film transistor including a substrate and sequentially forming an active layer, a first insulating layer, a gate electrode, a second insulating layer and source and drain electrodes on the substrate;

forming a gate line and a storage line, the storage line being formed parallel to the gate line and being spaced apart from the gate line;

forming a gate pad at a first end of the gate line;

forming a data line defining a pixel region by crossing the gate line, the data line being connected to the source electrode;

forming a data pad at a first end of the data line;

forming a third insulating layer over the thin film transistor and the data line, the third insulating layer being formed of transparent organic insulating material;

forming a fourth insulating layer on the third insulating layer, the fourth insulating layer being a barrier layer and being formed of inorganic insulating material;

forming a reflector on the barrier layer;

forming a drain contact hole over the drain electrode by depositing and patterning a fifth insulating layer on the reflector;

forming an inorganic insulating layer between the reflector and the pixel electrode; and

forming a transparent pixel electrode on the inorganic insulating layer, the pixel electrode contacting the drain electrode.

**33.** The method according to claim 32, further comprising:

forming an insulating layer beneath the organic insulating layer to perform a hydrogenation process of the thin film transistor

**34.** The method according to claim 32, further comprising:

forming a buffer layer beneath the active layer using an inorganic insulating material including silicon oxide ( $\text{SiO}_2$ ) or silicon nitride ( $\text{SiN}_x$ ).

**35.** The method according to claim 32, wherein

the active layer is formed of polysilicon.

**36.** The method according to claim 32, wherein

the storage line and gate line are formed with a same material and on a same layer.

**37.** The method according to claim 32, wherein

the reflector is formed of a conductive metal material including aluminum (Al) or an aluminum alloy.

**38.** The method according to claim 32, wherein

the pixel electrode is formed of transparent conductive material including indium tin oxide (ITO) or indium zinc oxide (IZO).

**39.** The method according to claim 32, wherein

the reflector is extended to the data line and covers the thin film transistor.

**40.** The method according to claim 32, wherein

the reflector is partially overlapped with the gate line or the data line.

**41.** The method according to claim 32, wherein

the reflector covers the thin film transistor.

**42.** The method according to claim 32, wherein

the barrier layer is formed using an inorganic insulating material including silicon oxide ( $\text{SiO}_2$ ) or silicon nitride ( $\text{SiN}_x$ ).

**43.** The method according to claim 32, wherein

the drain contact hole is formed by etching the third insulating layer, the fourth insulating layer and the fifth insulating layer simultaneously with an etching gas including about 65-80% of oxygen gas.

\* \* \* \* \*

专利名称(译)	用于反射和半透半反液晶显示装置的阵列基板及其制造方法		
公开(公告)号	<a href="#">US20020109811A1</a>	公开(公告)日	2002-08-15
申请号	US10/028759	申请日	2001-12-28
[标]申请(专利权)人(译)	PARK JUNE HO 崔在SIK		
申请(专利权)人(译)	PARK JUNE-HO 崔在植		
当前申请(专利权)人(译)	PARK JUNE-HO 崔在植		
[标]发明人	PARK JUNE HO CHOI JAE SIK		
发明人	PARK, JUNE-HO CHOI, JAE-SIK		
IPC分类号	G02F1/1335 G02F1/1362 G02F1/136		
CPC分类号	G02F1/133553 G02F1/133555 G02F1/136227 G02F2202/02		
优先权	1020010030699 2001-06-01 KR 1020010007097 2001-02-13 KR		
其他公开文献	US6833883		
外部链接	<a href="#">Espacenet</a> <a href="#">USPTO</a>		

摘要(译)

一种用于反射型液晶显示装置的阵列基板，包括栅极线和通过相互交叉限定像素区域的数据线；栅极线和数据线的交叉部分处的开关元件；第一钝化层，覆盖开关元件和数据线；并由无机绝缘材料制成；第一钝化层上的反射电极，连接到开关元件；和反射电极上的第二钝化层。第二钝化层由有机绝缘材料形成。

