

(19)



(11)

EP 2 122 410 B1

(12)

EUROPEAN PATENT SPECIFICATION

(45) Date of publication and mention of the grant of the patent:
07.03.2018 Bulletin 2018/10

(51) Int Cl.:
G02F 1/1333 (2006.01)

(21) Application number: **08753436.8**

(86) International application number:
PCT/KR2008/002640

(22) Date of filing: **09.05.2008**

(87) International publication number:
WO 2008/143418 (27.11.2008 Gazette 2008/48)

(54) **DISPLAY DEVICE**

ANZEIGEVORRICHTUNG

DISPOSITIF D’AFFICHAGE

(84) Designated Contracting States:
AT BE BG CH CY CZ DE DK EE ES FI FR GB GR HR HU IE IS IT LI LT LU LV MC MT NL NO PL PT RO SE SI SK TR

(30) Priority: **23.05.2007 KR 20070050367**
20.06.2007 KR 20070060230

(43) Date of publication of application:
25.11.2009 Bulletin 2009/48

(73) Proprietor: **LG Display Co., Ltd.**
Seoul 07336 (KR)

(72) Inventor: **LEE, Jung Mok**
Seoul 150-721 (KR)

(74) Representative: **Ter Meer Steinmeister & Partner**
Patentanwälte mbB
Nymphenburger Straße 4
80335 München (DE)

(56) References cited:
JP-A- 2000 147 469 KR-A- 20040 097 467
KR-A- 20050 068 198 KR-A- 20060 083 262
US-A1- 2004 212 754 US-A1- 2006 066 769
US-B2- 6 734 928

EP 2 122 410 B1

Note: Within nine months of the publication of the mention of the grant of the European patent in the European Patent Bulletin, any person may give notice to the European Patent Office of opposition to that patent, in accordance with the Implementing Regulations. Notice of opposition shall not be deemed to have been filed until the opposition fee has been paid. (Art. 99(1) European Patent Convention).

Description**Technical Field**

[0001] The present embodiment relates to a display device.

[0002] A liquid crystal display(LCD) that is one of display devices represent low power consumption, a light weight, and a small volume.

Background Art

[0003] A display device includes a liquid crystal panel that displays image information, and a backlight unit that provides light to the liquid crystal panel.

[0004] Since such a liquid crystal panel is a light receiving device that does not emit light by itself, the liquid crystal panel requires a backlight unit. Accordingly, the performance of a liquid crystal display mainly depends on the performance of a backlight unit as well as the liquid crystal panel.

[0005] The backlight unit comprises a backlight assembly, which includes a reflective sheet, a light guide plate, a prism sheet, a diffusion sheet, a protective sheet, and a light source, and a frame receiving the backlight unit.

[0006] The liquid crystal display is provided by coupling the backlight assembly and the liquid crystal panel to the frame.

Disclosure of Invention**Technical Problem**

[0007] The embodiment provides a display device.

Technical Solution

[0008] According to the embodiment, a display device comprises a display part comprising at least one of a liquid crystal panel and a backlight assembly, a frame receiving the display part, and a fixing member disposed between the display part and the frame.

[0009] According to the embodiment, a display device comprises a backlight assembly comprising a light guide plate, an optical sheet, and a reflective sheet, and a frame formed with a sidewall to receive and fix the backlight assembly, in which at least one portion of the backlight assembly is fixed to the frame by using a fixing member.

Advantageous Effects

[0010] According to the present embodiment, a display device can be realized by fixing the display device to a frame using a fixing member including resin.

[0011] In addition, since the fixing member comprises synthetic resin or polymer resin, the display device can be protected from an external shock.

[0012] Further, the coupling force between the frame and the display device can be enhanced due to the fixing member.

[0013] US 6 734 928 B2 describes a liquid crystal display device, wherein a resilient spacer is arranged inside of a metal frame and a liquid crystal display panel is fixed by utilizing a resiliency of protrusions of the spacer.

[0014] JP 2000147469 A describes a liquid crystal device. A frame member has a receiving space, in which a liquid crystal panel is disposed. The liquid crystal panel comprises two glass substrates with liquid crystal being disposed therebetween. Between inner sidewalls of the frame member and outer sidewalls of the liquid crystal panel, a resin is disposed.

Brief Description of the Drawings**[0015]**

FIG. 1 is an exploded perspective view showing a display device according to the first embodiment; FIG. 2 is a plan view showing the coupling of a frame and a light guide plate of a backlight assembly;

FIG. 3 is an enlarged view showing a portion of a display device shown in FIG. 2;

FIGS. 4 and 5 are enlarged views showing portions of a frame and a light guide plate having another shape according to the first embodiment;

FIGS. 6 and 7 are sectional views showing the coupling of a light guide plate and a reflective sheet to a frame according to the first embodiment;

FIG. 8 is a plan view showing a display device according to the second embodiment;

FIG. 9 is an exploded perspective view of a liquid crystal panel and a frame shown in FIG. 8;

FIG. 10 is an enlarged view of an A area shown in FIG. 8;

FIGS 11 and 12 are views showing the fixing member that is located in various positions different from the position shown in FIG. 9; and

FIGS. 13 and 14 are views showing a frame and a fixing member having another shape according to the second embodiment.

Mode for the Invention

[0016] FIG. 1 is an exploded perspective view showing a display device according to the first embodiment. FIG. 2 is a plan view showing the coupling of a frame and a light guide plate of a backlight assembly.

[0017] Referring to FIGS. 1 and 2, the display device comprises a liquid crystal panel 10, a backlight assembly 60, and a frame 100.

[0018] The liquid crystal panel 10, which displays image information, is formed by interposing a liquid crystal layer between a TFT substrate and a color filter substrate.

[0019] The backlight assembly 60 is installed at the

rear surface of the liquid crystal panel 10 so that light can be supplied to the liquid crystal panel 10. The backlight assembly 60 includes a light emitting part 30, a light guide plate 20, an optical sheet 50, and a reflective sheet 40.

[0020] The light emitting part 30 includes a light emitting diode (LED) or a cold cathode fluorescent lamp (CCFL) to emit light to the light guide plate 20.

[0021] The light guide plate 20 receives the light emitted from the light emitting part 30 to uniformly disperse the light over the entire light emission area of a backlight. The light guide plate 20 is provided at the side surface with at least one protrusion 25 such that the light guide plate 20 is received in the frame 100.

[0022] The optical sheet 50 is attached onto the top surface of the light guide plate 20, and includes a lens sheet, a diffusion sheet, or a protective sheet.

[0023] The reflective sheet 40 is attached onto the bottom surface of the light guide plate 20. The reflective sheet 40 reflects light, which is leaked from the light guide plate 20 downward, toward the light emission area of the backlight.

[0024] The frame 100 receives or fixes at least one of the liquid crystal panel and the backlight assembly 60 therein or thereto. For example, the frame 100 includes polycarbonate resin, styrene resin, or synthetic resin such as poly(vinyl chloride) or polypropylene.

[0025] The frame 100 includes sidewalls 110, 120, 130, and 140. For example, the frame 100 employs four sidewalls such that the sidewalls form a square-type frame. Hereinafter, the four sidewalls are referred to as the first sidewall 110, the second sidewall 120, the third sidewall 130, and the fourth sidewall 140.

[0026] The first sidewall 110 faces the third sidewall 130. The second sidewall 120 faces the fourth sidewall 140. Accordingly, the first to the fourth sidewalls 110 to 140 are connected to each other in a closed loop shape. The first to fourth sidewalls 110 to 140 form a square-shape frame when viewed in a plan view.

[0027] The first and third sidewalls 110 and 130 may have grooves 115 and 135 in a position corresponding to protrusions 25 formed at the side surface of the light guide plate 20.

[0028] Accordingly, when the light guide plate 20 is coupled to the frame 100, the protrusions 25 of the light guide plate 20 are inserted into the grooves 115 and 135 of the frame 100 so that the light guide plate 20 may be fixed to the frame 100.

[0029] Referring to FIGS. 2 and 3, the light guide plate 20 may be fixed to the frame 100 by using a fixing member 80. The fixing member 80 may be resin. For example, the fixing member 80 may be a liquid adhesive agent such as synthetic resin or silicon resin.

[0030] Reference number 90 represents an injector of a liquid adhesive agent.

[0031] In order to fix the light guide plate 20 to the frame 100, the light guide plate 20 is positioned on the frame 100. Then, the protrusions 25 of the light guide plate 20 are inserted into the grooves 115 and 135 of the first and

third sidewalls 110 and 130 of the frame 100 such that the light guide plate 20 is fixed to the frame 100.

[0032] A liquid adhesive agent including silicon resin is injected into a contact area between the frame 100 and the light guide plate 20. Then, the liquid adhesive agent is hardened so that the fixing member 80 is formed between the light guide plate 20 and the frame 100. In this case, the light guide plate 20 adheres to the frame 100.

[0033] Since the light guide plate 20 is fixed to the frame 100 by using the fixing member 80, the light guide plate 20 can be fixed to the frame 100 regardless of the thicknesses of the light guide plate 20 and the frame 100.

[0034] Accordingly, since the light guide plate 20 is coupled to the frame 100 by the fixing member 80, the light guide plate 20 can be stably coupled to the frame 100 even if the light guide plate 20 is thin.

[0035] In addition, even if the protrusions 25 and the grooves 115 and 135 are not formed in the light guide plate 20 and the frame 100, the light guide plate 20 is fixedly coupled to the frame 100 by using the fixing member 80.

[0036] FIGS. 4 and 5 are views showing a frame and a light guide plate having another shape.

[0037] Referring to FIG. 4, a zigzag protrusion part 237 may be formed on one of sidewalls of a frame 200.

[0038] If the zigzag protrusion part 237 is formed on sidewalls 220 and 230 of the frame 200, a contact area between the frame 200 and the fixing member 80 is widened when the frame 200 is coupled to the light guide plate 20, so that the coupling force between the fixing member 80 and the frame 200 can be more enhanced.

[0039] Referring to FIG. 5, a protrusion part 27 is formed on the side surface of the light guide plate 20. In addition, the zigzag protrusion part 237 may be formed on at least one among the sidewalls of the frame 200.

[0040] If the zigzag protrusion parts 27 and 237 are formed on the side surface of the light guide plate 20 and the sidewall of the frame 200, a coating area of the fixing member 80 is widened when the light guide plate 20 is coupled to the frame 200. Accordingly, the coupling force between the light guide plate 20 and the frame 200.

[0041] FIGS. 6 and 7 are a sectional view showing a reflective sheet when a light guide plate is coupled to a frame.

[0042] Referring to FIG. 6, when the light guide plate 20 is coupled to the frame 100, the reflective sheet 40 is fixedly coupled to the light guide plate 20 and the frame 200.

[0043] After the frame 100 is rested on the reflective sheet 40, the light guide plate 20 is coupled into the frame 100.

[0044] Thereafter, a liquid adhesive agent including resin is injected into the contact area between the frame 100 and the light guide plate 20. The liquid adhesive agent is injected into a space between the frame 100 and the light guide plate 20 so that the liquid adhesive agent is penetrated into the reflective sheet 40 positioned in the lower portion of the frame 100.

[0045] Then, the liquid adhesive is hardened so that the fixing member 80 is formed between the light guide plate 20 and the frame 100. The fixing member 80 makes contact with the reflective sheet 40 so that the reflective sheet 40 can be fixed to the frame 100.

[0046] Accordingly, when the light guide plate 20 makes contact with the frame 100, the reflective sheet 40 is simultaneously fixed to the light guide plate 20 and the frame 100.

[0047] Meanwhile, since an additional fixing unit such as an adhesive tape is not required in order to fix the reflective sheet 40 to the frame 100, a manufacturing process can be simplified, and the manufacturing cost can be reduced.

[0048] In addition, since the additional fixing unit such as the adhesive tape is not required, a slim and small-sized backlight unit can be realized.

[0049] Referring to FIG. 7, when the light guide plate 20 is coupled to the frame 100, the reflective sheet 41 is fixedly coupled to the light guide plate 20 and the frame 100 at the same time.

[0050] In particular, the reflective sheet 41 may be formed more widely than the frame 100. If the reflective sheet 41 is formed more widely than the frame 100, the reflective sheet 41 may be fixed onto the sidewalls 110 and 130 of the frame 100 while surrounding the lower portion of the frame 100.

[0051] In other words, the reflective sheet 41 may be fixed to the frame 100 by the fixing member 80 formed in the contact area between the light guide plate 20 and the frame 100.

[0052] Further, a portion of the reflective sheet 41 positioned on the sidewalls 110 and 130 of the frame 100, which is the outer peripheral surfaces of the frame 100, may be bonded to the frame 100 by using an adhesive member 70 such as an adhesive tape.

[0053] Accordingly, when the light guide plate 20 is bonded to the frame 100 by using the fixing member 80, the reflective sheet 41 is simultaneously fixed to the light guide plate 20 and the frame 100. At this time, the reflective sheet is additionally bonded to the sidewall of the frame 100, so that the adhesive strength of the reflective sheet 41 may be enhanced.

[0054] In the display device and a method for manufacturing the same according to the first embodiment, a backlight assembly is fixed to a frame by using a fixing member including resin. Accordingly, the coupling force between the backlight assembly and the frame is enhanced so that the reliability of the display device can be improved.

[0055] Further, when a thin backlight assembly is employed, since the thin backlight assembly is coupled to a frame by using a fixing member including resin, a slim and small-sized backlight unit can be realized.

[0056] In addition, according to the first embodiment, although a fixing member is used when a frame is coupled to a backlight assembly, the fixing member may be used even when a liquid crystal panel is coupled to the frame

with the backlight assembly.

[0057] Hereinafter, a display device and a method for manufacturing the same according to the second embodiment will be described with reference to FIGS. 8 to 14.

[0058] FIG. 8 is a front view showing a display device according to the second embodiment, and FIG. 9 is an exploded perspective view of the display device shown in FIG. 8.

5 **[0059]** Referring to FIGS. 8 and 9, the display device comprises a liquid crystal panel 10, a backlight assembly 60, a frame 400, and a fixing member 500. The liquid crystal panel 10 and the backlight assembly 60 are identical to those of the first embodiment, and details thereof will be omitted.

[0060] The liquid crystal panel 10 and the backlight assembly 60 must be received and fixed. To this end, the frame 400 and the fixing member 500 are used.

[0061] The frame 400 is a square-type frame having opened front and rear portions so that the liquid crystal panel 10 and the backlight assembly 60 can be received and fixed. Although it is not shown in drawings, the frame 400 may be a square-type frame, only a front portion of which is opened. In the following description, the frame 400 having opened front and rear portions will be described as an example.

[0062] Since the liquid crystal panel 10 and the backlight assembly 60 have a square structure, the frame 400 according to the embodiment may be a square-type frame. However, according to the embodiment, the structure of the frame 400 is not limited to one shape.

[0063] The frame 400 includes a side surface support part 410 for supporting the side surfaces of the liquid crystal panel 10 and the backlight assembly 60, and a rear surface support part 420 vertically bent from the side surface support part 410 in order to support the rear surfaces of the liquid crystal panel 10 and the backlight assembly 60.

[0064] Since the frame 400 includes metal such as steel or alloy steel, the frame 400 may be formed thin.

[0065] If the liquid crystal panel 10 and the backlight assembly 60 are rested into the frame 400, the side surface support part 410 of the frame 400 makes contact with the side surfaces of the liquid crystal panel 10 and the backlight assembly 60, and the rear surface support part 420 makes contact with the boundary of the rear surface of the backlight assembly 60.

[0066] In this case, the frame 400 may be slightly larger than the liquid crystal panel 10 and the backlight assembly 60. Accordingly, a space may be created in the contact area between the frame 400 and the liquid crystal panel 10 and the backlight assembly 60. In order to enhance the coupling strength between the frame 400 and the liquid crystal panel 10 and the backlight assembly 60, the fixing member 500 is formed in the space.

[0067] The fixing member 500 is used to fix the liquid crystal panel 10 and the backlight assembly 60 onto the frame 400, and includes resin. For example, the fixing

member 500 includes synthetic resin or silicon resin.

[0068] In particular, the silicon resin has superior heat resistance, water resistance, weather-resistance, and fouling resistance, and has superior elasticity even after the silicon resin is hardened.

[0069] Hereinafter, a scheme of coupling the frame 400 and the liquid crystal panel 10 and the backlight assembly 60 will be described.

[0070] The liquid crystal panel 10 and the backlight assembly 60 are rested into the frame 400. In addition, liquid-phase resin is injected into the space between the frame 400 and the liquid crystal panel 10 and the backlight assembly 60.

[0071] If the resin is hardened after predetermined time lapses, the side surface support part 410 and the rear surface support part 420 of the frame 400 adhere to the side surfaces and the rear surfaces of at least one of the liquid crystal panel 10 and the backlight assembly 60. Accordingly, the frame 400 can be coupled to the liquid crystal panel 10 and the backlight assembly 60 by the fixing member 500.

[0072] FIG. 10 is an enlarged view of an A area shown in FIG. 8, and FIGS 11 and 12 are views showing the fixing member of FIG. 10 that is selectively formed.

[0073] Referring to FIG. 10, the fixing member 500 may be formed by injecting silicon resin into the entire side surfaces of the liquid crystal panel 10 after the liquid crystal panel 10 is mounted on the frame 400. Then, the liquid crystal panel 10 may be fixedly coupled to the frame 400 by using the fixing member 500.

[0074] Although it is not shown in the drawings, the backlight assembly 60 may be provided at the lower portion of the liquid crystal panel 10. Accordingly, the backlight assembly 60 may be fixed to the frame 400 together with the liquid crystal panel 10 by using the fixing member 500.

[0075] Referring to FIG. 11, a fixing member 520 can be formed in a corner area in which the liquid crystal panel 10 makes contact with the frame 400.

[0076] Silicon resin may be injected only into the corner area of the frame 400 after the liquid crystal panel 10 is mounted on the frame 400, thereby forming the fixing member 520.

[0077] Accordingly, the liquid crystal panel 10 can be fixedly coupled to the frame 400 by the fixing member 520.

[0078] Referring to FIG. 12, a fixing member 530 is selectively formed at the side surfaces except for the corner area of the liquid crystal panel 10 and the frame 400.

[0079] Silicon resin may be selectively injected into the side surfaces except for the corner area of the frame 400 after the liquid crystal panel 10 is mounted on the frame 400, thereby forming the fixing member 530.

[0080] Accordingly, the liquid crystal panel 10 can be fixedly coupled to the frame 400 by the fixing member 530.

[0081] Referring to FIGS. 13 and 14, a frame 450 is formed as a square-shape frame, and may be formed

with an opened corner area.

[0082] Referring to FIG. 13, silicon resin may be injected into the corner area of the liquid crystal panel 10 after the liquid crystal panel 10 is mounted on the frame 450, thereby forming a fixing member 550 to fill the opened corner area of the frame 450.

[0083] Accordingly, the fixing member 550 bonds the liquid crystal panel 10 with the frame 450. In addition, the fixing member 550 fills the opened corner area of the frame 450, so that the strength of the frame 450 can be more enhanced.

[0084] Referring to FIG. 14, silicon resin is injected into a corner area of the liquid crystal panel 10 after the liquid crystal panel 10 is mounted on the frame 450, thereby forming a fixing member 570. In this case, the fixing member 570 may protrude out of the opened corner area of the frame 450.

[0085] Accordingly, the fixing member 570 bonds the liquid crystal panel 10 with the frame 450. In addition, the fixing member 570 protrudes out of the opened corner area of the frame 450 to protect the liquid crystal panel 10 when an external structure such as a case 600 is mounted outside the frame 450.

[0086] In other words, the fixing member 570 protrudes outward the frame 450 to absorb the shock occurring when the frame 450 makes contact with the case 600, so that the fixing member 570 can protect the liquid crystal panel 10.

[0087] Although the fixing member 570 is formed in the corner area of the frame 450 and the liquid crystal panel 10 as an example in the drawings, the fixing member 570 may be entirely or selectively formed at the side surfaces of the liquid crystal panel 10 and the frame 450.

[0088] In a display device and a method for manufacturing the same according to the second embodiment, since a frame, into which a liquid crystal panel and a backlight assembly are received and fixed, includes a chassis, which is coupled to an existing mold frame in order to enhance the strength of the mold frame, the thickness of the display device can be reduced by the thickness of the mold frame.

[0089] Further, in the display device, silicon resin is injected into the frame on which the liquid crystal panel and the backlight assembly are mounted, so that the frame can be coupled to the liquid crystal panel and the backlight assembly. Accordingly, since a conventional mold frame forming process and a conventional chassis coupling process, or a conventional chassis insertion process are omitted, a manufacturing process is simplified so that the manufacturing time can be saved, and the manufacturing cost can be reduced.

[0090] In addition, the display device can be protected from an external shock by a fixing member interposed between the frame and the backlight assembly and the liquid crystal panel. This is because the fixing member includes silicon resin having an elastic force. Accordingly, even if the liquid crystal panel and the backlight assembly are shocked, the liquid crystal panel and the backlight

assembly are primarily protected by the frame, and secondarily protected by the elastic force of the fixing member positioned inside the frame. Especially, the fixing member formed between a steel frame and the liquid crystal panel and the backlight assembly serves as a cushion, so that the display device can be more safely protected.

[0091] In addition, since the backlight assembly and the liquid crystal panel are coupled to the frame by the fixing member including resin, the manufacturing time can be saved, and the manufacturing cost can be reduced. In detail, since a conventional taping process, which is employed to fix a liquid crystal panel onto a mold frame on which a backlight assembly is mounted, is omitted, the manufacturing process is simplified so that the manufacturing cost can be reduced.

[0092] Any reference in this specification to "one embodiment", "an embodiment," "example embodiment," etc., means that a particular feature, structure, or characteristic described in connection with the embodiment is included in at least one embodiment of the invention. The appearances of such phrases in various places in the specification are not necessarily all referring to the same embodiment. Further, when a particular feature, structure, or characteristic is described in connection with any embodiment, it is submitted that it is within the purview of one skilled in the art to effect such feature, structure, or characteristic in connection with other ones of the embodiments.

[0093] Although embodiments have been described with reference to a number of illustrative embodiments thereof, it should be understood that numerous other modifications and embodiments can be devised by those skilled in the art that will fall within the scope of the principles of this disclosure. More particularly, various variations and modifications are possible in the component parts and/or arrangements of the subject combination arrangement within the scope of the disclosure, the drawings and the appended claims. In addition to variations and modifications in the component parts and/or arrangements, alternative uses will also be apparent to those skilled in the art.

Industrial Applicability

[0094] The embodiment relates to a display module.

Claims

1. A display device comprising:

a display part comprising at least one of a liquid crystal panel (10) and a backlight assembly (60); a frame (100, 400, 450) receiving the display part; and a fixing member (80, 500, 520, 530, 550, 570) disposed between the display part and the frame

(100, 400, 450);

wherein the fixing member (80, 500, 520, 530, 550, 570) is entirely or selectively formed between the frame (100, 400, 450) and the display part by injection of a liquid adhesive agent, wherein the frame (100, 400, 450) has a central opening and an inner sidewall (110, 130) which receives a light guide plate (20) of the backlight assembly (60) the backlight assembly (60) comprises a reflective sheet (40, 41),

characterized in that

the reflective sheet (40, 41) is formed at the outer surface of the frame (100, 400, 450) and is positioned at a lower-most portion of the backlight assembly (60)

wherein the fixing member (80, 500, 520, 530, 550, 570) is formed between the inner side wall (110, 130) of the frame (100, 400, 450), an edge of the light guide plate (20) and the reflective sheet (40, 41).

2. The display device as claimed in claim 1, wherein the frame (100, 400, 450) comprises metal or synthetic resin, and the fixing member (80, 500, 520, 530, 550, 570) comprises resin.
3. The display device as claimed in claim 1, wherein the frame (100, 400, 450) is formed as a square frame having an opened corner part, and the fixing member (80, 500, 520, 530, 550, 570) is formed in a corner area formed between the frame (100, 400, 450) and the display part.
4. The display device as claimed in claim 1, wherein the fixing member (80, 500, 520, 550, 570) is formed at a corner area or a side portion of the frame (100, 400, 450) and the display part.
5. The display device as claimed in claim 1, comprising a zigzag protrusion (27, 237) formed in at least one of an inner peripheral surface of a sidewall (110, 120, 130, 140; 410, 420, 430, 440) of the frame (100, 400, 450) and a portion of an outer peripheral surface of the backlight assembly (60).
6. The display device as claimed in claim 3, wherein the fixing member (80, 500, 520, 530, 550, 570) formed at the corner area of the frame (100, 400, 450) protrudes beyond a sidewall (110, 120, 130, 140; 410, 420, 430, 440) of the frame (100, 400, 450).
7. The display device as claimed in claim 1, wherein:
 - the backlight assembly (60) comprises the light guide plate (20), an optical sheet (50), and the reflective sheet (40, 41); and
 - the frame (100, 400, 450) is formed with a sidewall to receive the backlight assembly (60),

wherein at least one portion of the backlight assembly (60) is fixed to the frame (100, 400, 450) by using the fixing member (80, 500, 520, 530, 550, 570).

8. The display device as claimed in claim 7, wherein at least one protrusion (25) is formed at a side surface of the light guide plate (20), wherein a groove (115, 135) is formed at an inner peripheral surface of a sidewall of the frame (100, 400, 450) corresponding to the protrusion of the light guide plate.
9. The display device as claimed in claim 7, comprising a zigzag protrusion (27, 237) formed at least one of an inner peripheral surface of a sidewall (110, 120, 130, 140; 410, 420, 430, 440) of the frame (100, 400, 450) and an outer peripheral surface of the light guide plate (20).
10. The display device as claimed in claim 7, wherein the reflective sheet (41) is provided to surround a bottom surface and an outer peripheral surface of a sidewall (110, 120, 130, 140; 410, 420, 430, 440) of the frame (100, 400, 450), and is fixed to the outer peripheral surface of the sidewall of the frame (100, 400, 450) by using an adhesive tape.

Patentansprüche

1. Anzeigevorrichtung, die Folgendes umfasst:

einen Anzeigeteil, der eine Flüssigkristalltafel (10) und/oder eine Hintergrundbeleuchtungsanordnung (60) enthält;
 einen Rahmen (100, 400, 450), der den Anzeigeteil aufnimmt, und
 ein Befestigungselement (80, 500, 520, 530, 550, 570), das zwischen dem Anzeigeteil und dem Rahmen (100, 400, 450) angeordnet ist; wobei das Befestigungselement (80, 500, 520, 530, 550, 570) vollständig oder selektiv durch Einspritzen eines flüssigen Klebstoffs zwischen den Rahmen (100, 400, 450) und den Anzeigeteil gebildet ist,
 wobei der Rahmen (100, 400, 450) eine mittige Öffnung und eine innere Seitenwand (110, 130), die die Lichtleiterplatte (20) der Hintergrundbeleuchtungsanordnung (60) aufnimmt, aufweist und
 die Hintergrundbeleuchtungsanordnung (60) eine reflektierende Schicht (40, 41) umfasst,
dadurch gekennzeichnet, dass
 die reflektierende Schicht (40, 41) an der äußeren Oberfläche des Rahmens (100, 400, 450) gebildet und am untersten Abschnitt der Hintergrundbeleuchtungsanordnung (60) positioniert

ist,

wobei das Befestigungselement (80, 500, 520, 530, 550, 570) zwischen der inneren Seitenwand (110, 130) des Rahmens (100, 400, 450), einer Kante der Lichtleiterplatte (20) und der reflektierenden Schicht (40, 41) gebildet ist.

2. Anzeigevorrichtung nach Anspruch 1, wobei der Rahmen (100, 400, 450) Metall oder ein synthetisches Harz enthält und das Befestigungselement (80, 500, 520, 530, 550, 570) Harz enthält.
3. Anzeigevorrichtung nach Anspruch 1, wobei der Rahmen (100, 400, 450) als ein quadratischer Rahmen gebildet ist, der einen offenen Eckabschnitt aufweist und das Befestigungselement (80, 500, 520, 530, 550, 570) in einem Eckbereich gebildet ist, der zwischen dem Rahmen (100, 400, 450) und dem Anzeigeteil gebildet ist.
4. Anzeigevorrichtung nach Anspruch 1, wobei das Befestigungselement (80, 500, 520, 550, 570) an einem Eckbereich oder einem Seitenabschnitt des Rahmens (100, 400, 450) und des Anzeigeteils gebildet ist.
5. Anzeigevorrichtung nach Anspruch 1, die einen Zickzacküberstand (27, 237) umfasst, der in einer inneren Umfangsoberfläche einer Seitenwand (110, 120, 130, 140; 410, 420, 430, 440) des Rahmens (100, 400, 450) und/oder einem Abschnitt einer äußeren Umfangsoberfläche der Hintergrundbeleuchtungsanordnung (60) gebildet ist.
6. Anzeigevorrichtung nach Anspruch 3, wobei das Befestigungselement (80, 500, 520, 530, 550, 570), das an dem Eckbereich des Rahmens (100, 400, 450) gebildet ist, über eine Seitenwand (110, 120, 130, 140; 410, 420, 430, 440) des Rahmens (100, 400, 450) übersteht.
7. Anzeigevorrichtung nach Anspruch 1, wobei:
 - die Hintergrundbeleuchtungsanordnung (60) die Lichtleiterplatte (20), eine optische Schicht (50) und die reflektierende Schicht (40, 41) umfasst und
 - der Rahmen (100, 400, 450) mit einer Seitenwand gebildet ist, um die Hintergrundbeleuchtungsanordnung (60) aufzunehmen, wobei mindestens ein Abschnitt der Hintergrundbeleuchtungsanordnung (60) unter Verwendung des Befestigungselements (80, 500, 520, 530, 550, 570) an dem Rahmen (100, 400, 450) befestigt ist.
8. Anzeigevorrichtung nach Anspruch 7, wobei mindestens ein Überstand (25) an einer Sei-

tenoberfläche der Lichtleiterplatte (20) gebildet ist, wobei eine Nut (115, 135) an einer inneren Umfangsoberfläche einer Seitenwand des Rahmens (100, 400, 450) gebildet ist, die dem Überstand der Lichtleiterplatte entspricht.

9. Anzeigevorrichtung nach Anspruch 7, die einen Zickzacküberstand (27, 237) umfasst, der in einer inneren Umfangsoberfläche einer Seitenwand (110, 120, 130, 140; 410, 420, 430, 440) des Rahmens (100, 400, 450) und/oder einer äußeren Umfangsoberfläche der Lichtleiterplatte (20) gebildet ist.
10. Anzeigevorrichtung nach Anspruch 7, wobei die reflektierende Schicht (41) vorgesehen ist, eine untere Oberfläche und eine äußere Umfangsoberfläche einer Seitenwand (110, 120, 130, 140; 410, 420, 430, 440) des Rahmens (100, 400, 450) zu umgeben, und unter Verwendung eines Klebebandes an der äußeren Umfangsoberfläche der Seitenwand des Rahmens (100, 400, 450) befestigt ist.

Revendications

1. Dispositif d'affichage comprenant :

une partie d'affichage comprenant au moins l'un d'un panneau à cristaux liquides (10) et d'un ensemble de rétroéclairage (60) ;

un cadre (100, 400, 450) recevant la partie d'affichage ; et

un organe de fixation (80, 500, 520, 530, 550, 570) disposé entre la partie d'affichage et le cadre (100, 400, 450) ;

dans lequel l'organe de fixation (80, 500, 520, 530, 550, 570) est entièrement ou sélectivement formé entre le cadre (100, 400, 450) et la partie d'affichage par injection d'un agent adhésif liquide,

dans lequel le cadre (100, 400, 450) comporte une ouverture centrale et une paroi latérale intérieure (110, 130) qui reçoit une plaque de guidage de lumière (20) de l'ensemble de rétroéclairage (60),

l'ensemble de rétroéclairage (60) comprend une feuille réfléchissante (40, 41),

caractérisé en ce que

la feuille réfléchissante (40, 41) est formée à la surface extérieure du cadre (100, 400, 450) et est positionnée à la plus basse portion de l'ensemble de rétroéclairage (60),

dans lequel l'organe de fixation (80, 500, 520, 530, 550, 570) est formé entre la paroi latérale intérieure (110, 130) du cadre (100, 400, 450), un bord de la plaque de guidage de lumière (20) et la feuille réfléchissante (40, 41).

2. Dispositif d'affichage selon la revendication 1, dans lequel le cadre (100, 400, 450) comprend un métal ou une résine synthétique, et l'organe de fixation (80, 500, 520, 530, 550, 570) comprend une résine.

3. Dispositif d'affichage selon la revendication 1, dans lequel le cadre (100, 400, 450) est formé en tant que cadre carré comportant une partie de coin ouverte, et l'organe de fixation (80, 500, 520, 530, 550, 570) est formé dans une zone de coin formée entre le cadre (100, 400, 450) et la partie d'affichage.

4. Dispositif d'affichage selon la revendication 1, dans lequel l'organe de fixation (80, 500, 520, 550, 570) est formé à une zone de coin ou à une portion latérale du cadre (100, 400, 450) et la partie d'affichage.

5. Dispositif d'affichage selon la revendication 1, comprenant une protubérance en zigzag (27, 237) formée dans au moins l'une d'une surface périphérique intérieure d'une paroi latérale (110, 120, 130, 140 ; 410, 420, 430, 440) du cadre (100, 400, 450) et d'une portion d'une surface périphérique extérieure de l'ensemble de rétroéclairage (60).

6. Dispositif d'affichage selon la revendication 3, dans lequel l'organe de fixation (80, 500, 520, 530, 550, 570) formé à la zone de coin du cadre (100, 400, 450) fait saillie au-delà d'une paroi latérale (110, 120, 130, 140 ; 410, 420, 430, 440) du cadre (100, 400, 450) .

7. Dispositif d'affichage selon la revendication 1, dans lequel :

l'ensemble de rétroéclairage (60) comprend la plaque de guidage de lumière (20), une feuille optique (50) et la feuille réfléchissante (40, 41) ; et

le cadre (100, 400, 450) est constitué d'une paroi latérale pour recevoir l'ensemble de rétroéclairage (60), dans lequel au moins une portion de l'ensemble de rétroéclairage (60) est fixée au cadre (100, 400, 450) par l'utilisation de l'organe de fixation (80, 500, 520, 530, 550, 570).

8. Dispositif d'affichage selon la revendication 7, dans lequel au moins une protubérance (25) est formée à une surface latérale de la plaque de guidage de lumière (20), dans lequel une rainure (115, 135) est formée à une surface périphérique intérieure d'une paroi latérale du cadre (100, 400, 450) correspondant à la protubérance de la plaque de guidage de lumière.

9. Dispositif d'affichage selon la revendication 7, comprenant une protubérance en zigzag (27, 237) formée dans au moins l'une d'une surface périphérique

intérieure d'une paroi latérale (110, 120, 130, 140 ; 410, 420, 430, 440) du cadre (100, 400, 450) et d'une surface périphérique extérieure de la plaque de guidage de lumière (20).

5

- 10.** Dispositif d'affichage selon la revendication 7, dans lequel la feuille réfléchissante (41) est prévue pour entourer une surface inférieure et une surface périphérique extérieure d'une paroi latérale (110, 120, 130, 140 ; 410, 420, 430, 440) du cadre (100, 400, 450), et est fixée à la surface périphérique extérieure de la paroi latérale du cadre (100, 400, 450) par l'utilisation d'un ruban adhésif.

10

15

20

25

30

35

40

45

50

55

[Fig. 1]

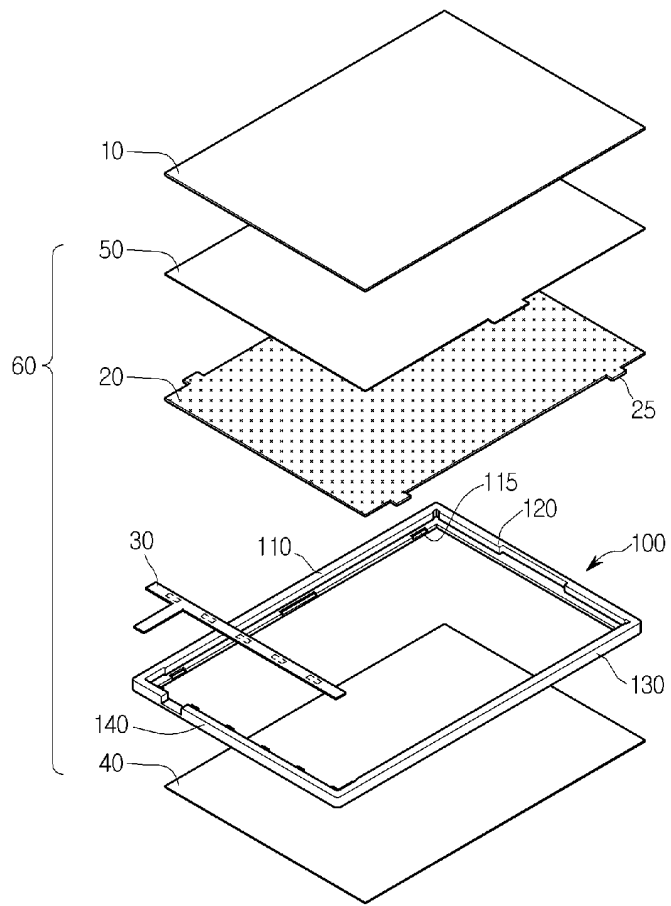

[Fig. 2]

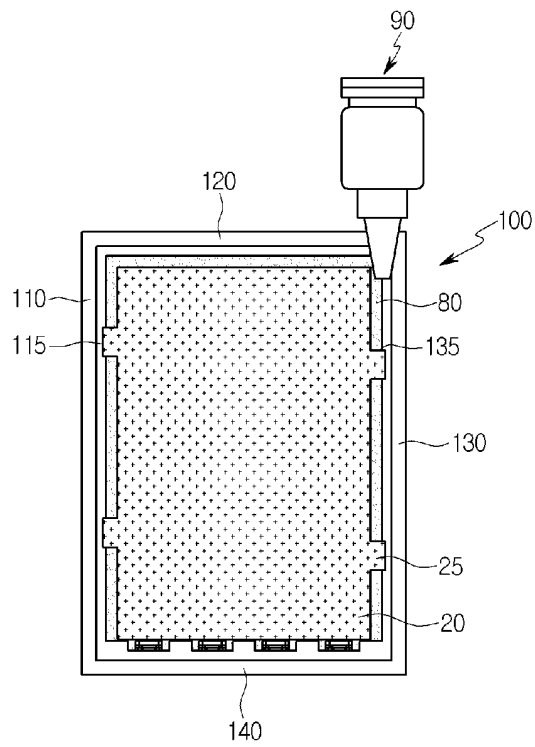

[Fig. 3]

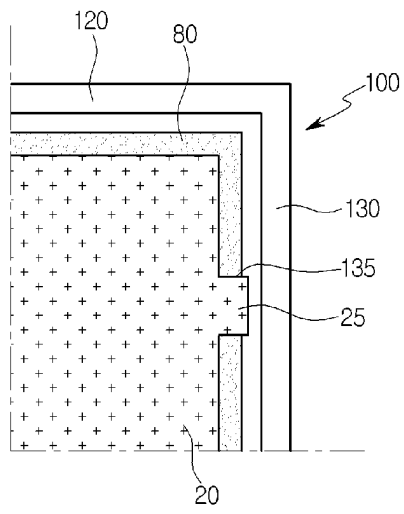

[Fig. 4]

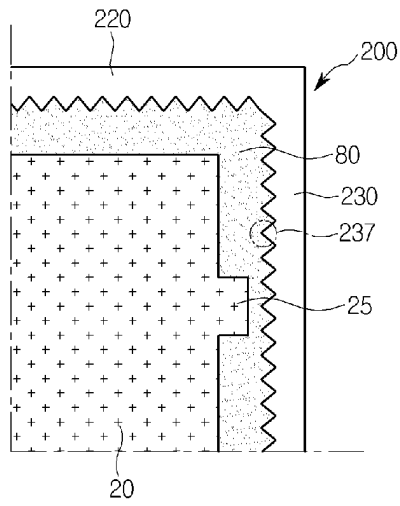

[Fig. 5]

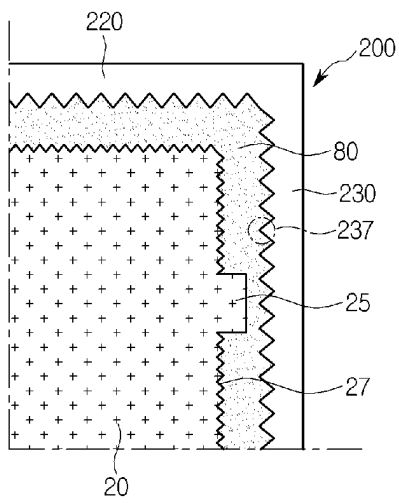

[Fig. 6]

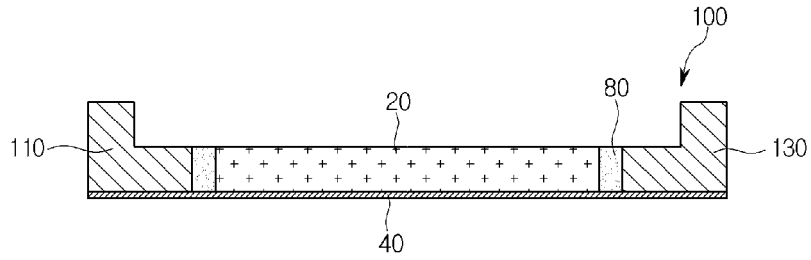

[Fig. 7]

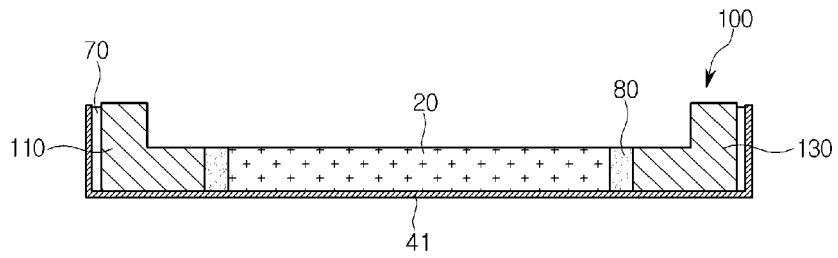

[Fig. 8]

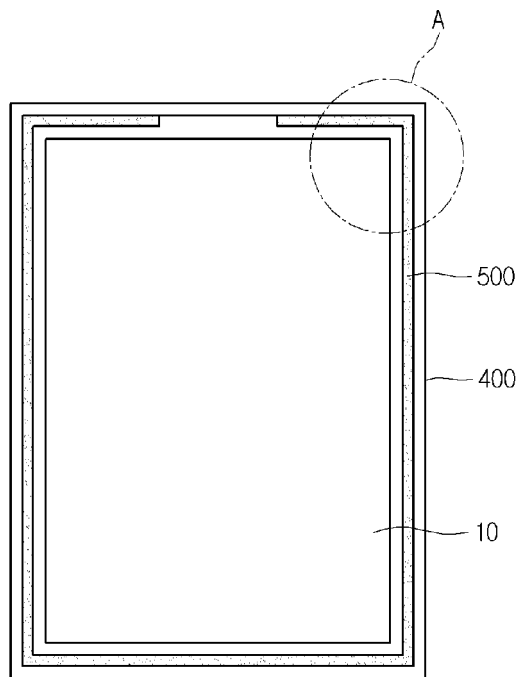

[Fig. 9]

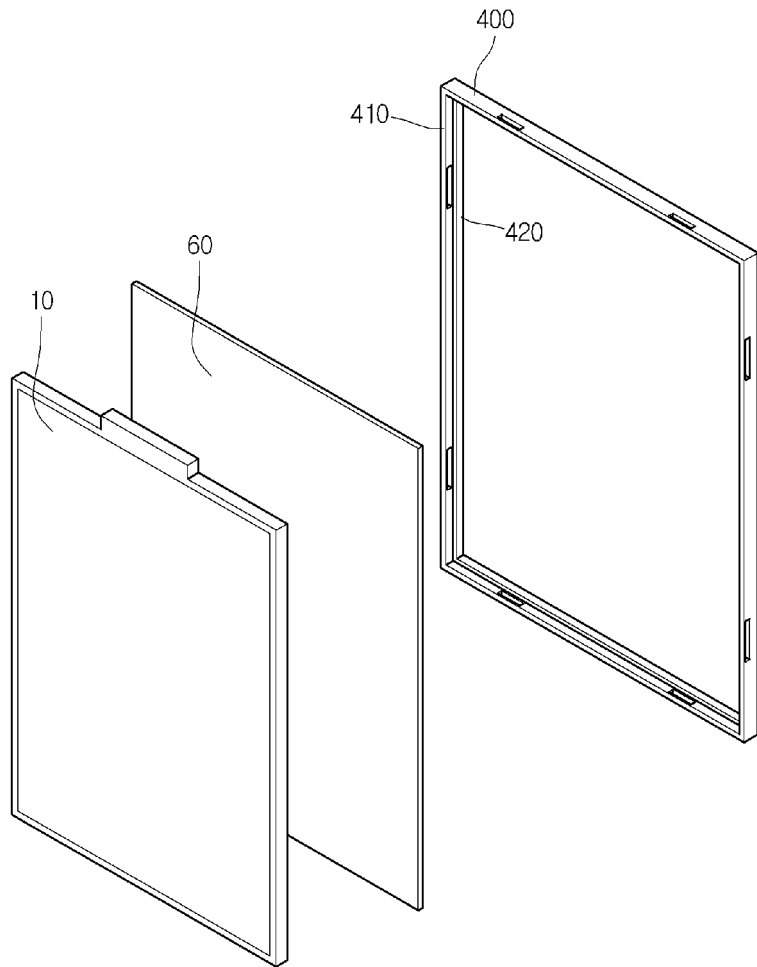

[Fig. 10]

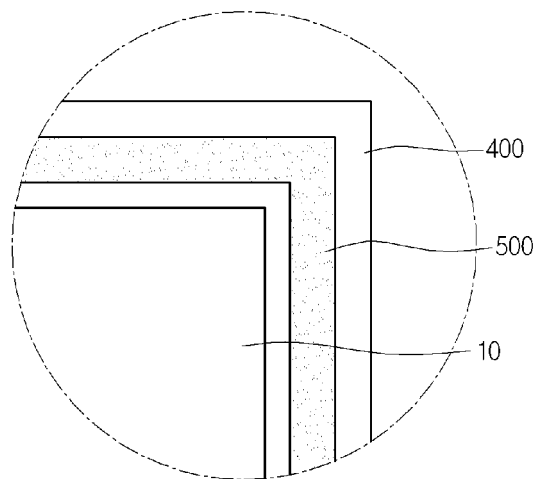

[Fig. 11]

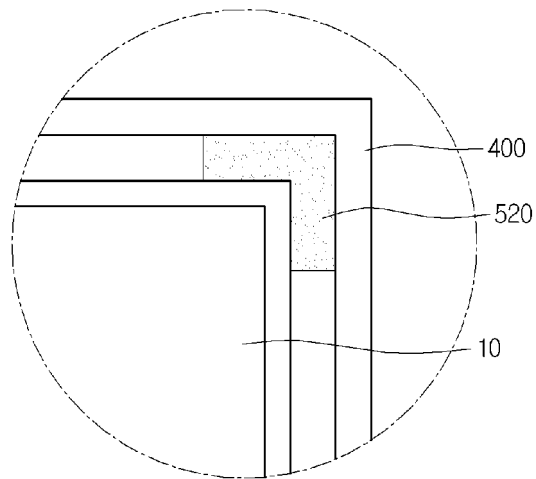

[Fig. 12]

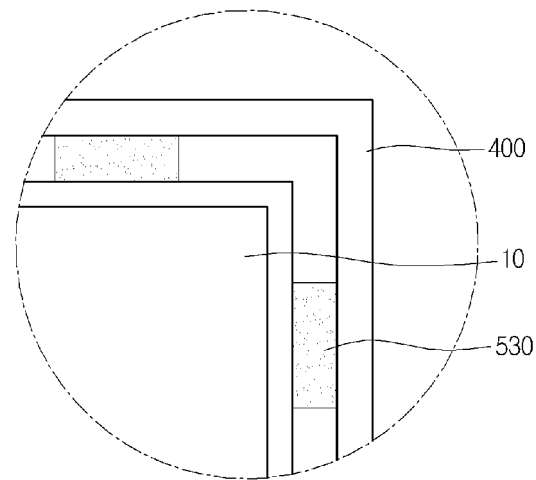

[Fig. 13]

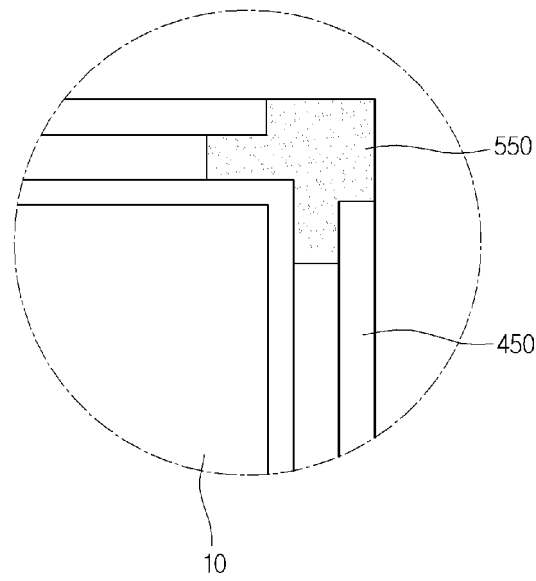

[Fig. 14]

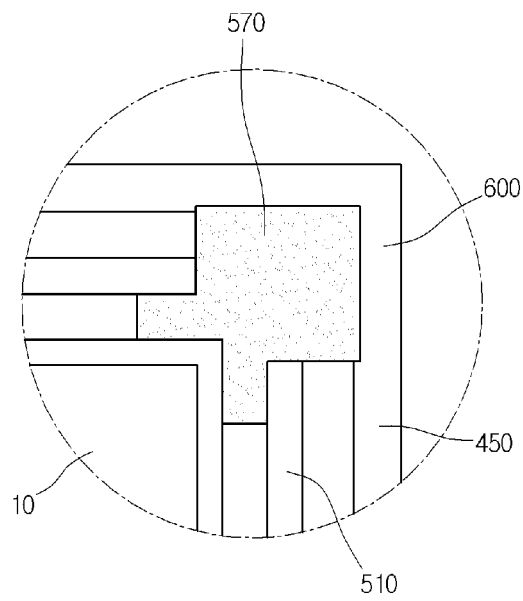

REFERENCES CITED IN THE DESCRIPTION

This list of references cited by the applicant is for the reader's convenience only. It does not form part of the European patent document. Even though great care has been taken in compiling the references, errors or omissions cannot be excluded and the EPO disclaims all liability in this regard.

Patent documents cited in the description

- US 6734928 B2 [0013]
- JP 2000147469 A [0014]

专利名称(译)	显示设备		
公开(公告)号	EP2122410B1	公开(公告)日	2018-03-07
申请号	EP2008753436	申请日	2008-05-09
[标]申请(专利权)人(译)	印诺泰克公司		
申请(专利权)人(译)	LG INNOTEK CO. , LTD.		
当前申请(专利权)人(译)	LG DISPLAY CO. , LTD.		
[标]发明人	LEE JUNG MOK		
发明人	LEE, JUNG MOK		
IPC分类号	G02F1/1333		
CPC分类号	G02B6/0088 G02B6/0093 G02F1/133308 G02F2201/503 G02F2202/28		
优先权	1020070050367 2007-05-23 KR 1020070060230 2007-06-20 KR		
其他公开文献	EP2122410A4 EP2122410A1		
外部链接	Espacenet		

摘要(译)

公开了一种显示装置。通过使用诸如硅的树脂将液晶面板和背光组件固定到框架，从而实现纤薄和小尺寸的显示装置。

[Fig. 1]

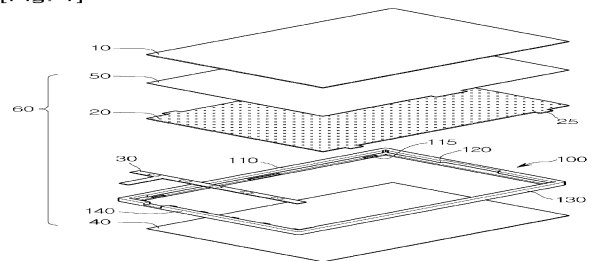

[Fig. 2]

