

(19) World Intellectual Property Organization
International Bureau



(43) International Publication Date
25 May 2001 (25.05.2001)

PCT

(10) International Publication Number
WO 01/37251 A1

- (51) International Patent Classification⁷: **G09G 3/36** [JP/NL]; Prof. Holstlaan 6, NL-5656 AA Eindhoven (NL).
YASUI, Masaru [JP/NL]; Prof. Holstlaan 6, NL-5656 AA Eindhoven (NL). **KAMIYA, Takeo** [JP/NL]; Prof. Holstlaan 6, NL-5656 AA Eindhoven (NL). **SHUJI, Hagino** [JP/NL]; Prof. Holstlaan 6, NL-5656 AA Eindhoven (NL).
- (21) International Application Number: PCT/EP00/11288
- (22) International Filing Date:
10 November 2000 (10.11.2000)
- (25) Filing Language: English
- (26) Publication Language: English
- (30) Priority Data:
9/321902 12 November 1999 (12.11.1999) JP
2000-330859 30 October 2000 (30.10.2000) JP
- (71) Applicant (for all designated States except US): **KONINKLIJKE PHILIPS ELECTRONICS N.V.** [NL/NL]; Groenewoudseweg 1, NL-5621 BA Eindhoven (NL).
- (72) Inventors; and
- (75) Inventors/Applicants (for US only): **HIRANO, Satoshi**
- (74) Agent: **BAELE, Ingrid, A., F., M.**; Internationaal Octrooibureau B.V., Prof. Holstlaan 6, NL-5656 AA Eindhoven (NL).
- (81) Designated States (national): CN, KR, US.
- (84) Designated States (regional): European patent (AT, BE, CH, CY, DE, DK, ES, FI, FR, GB, GR, IE, IT, LU, MC, NL, PT, SE, TR).
- Published:**
— With international search report.

For two-letter codes and other abbreviations, refer to the "Guidance Notes on Codes and Abbreviations" appearing at the beginning of each regular issue of the PCT Gazette.

(54) Title: LIQUID CRYSTAL DISPLAY DEVICE WITH HIGH BRIGHTNESS

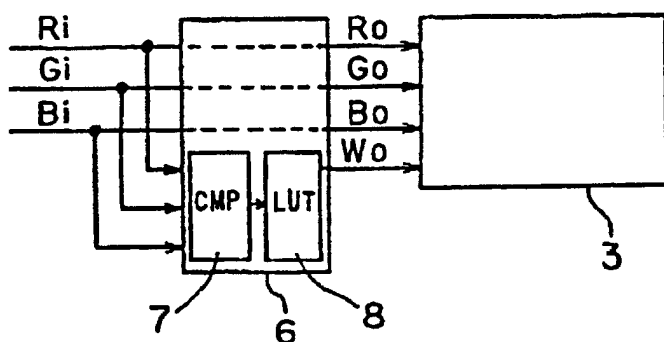

(57) Abstract: This invention relates to an RGBW-typed LCD wherein a proper luminous image can be displayed according to a predetermined calculation with a decoder where some predetermined calculation formulas are embedded. Further, not only RGBW image display but also RGB image display can be used by a predetermined controlling signal.

WO 01/37251 A1

LIQUID CRYSTAL DISPLAY DEVICE WITH HIGH BRIGHTNESS

This invention relates to a liquid crystal display apparatus capable of color displaying.

In recent years, a liquid crystal display apparatus capable of color displaying is widely used as a display apparatus, for example, for a personal computer, a video camera and a car navigation system.

A Liquid crystal display apparatus of RGBW type (hereinafter referred to as a RGBW type liquid crystal display apparatus) in which a transparent filter (W) is arranged in addition to a RGB filter of the conventional RGB type has been proposed in Japanese Patent Application Laid-open No.10998/1998, which relates to a method for improving luminance of a pixel of a liquid crystal panel of this liquid crystal display apparatus.

However, even though attempting improvement of luminance of the liquid crystal panel by merely adding the transparent filter, a white color is mixed in all display colors if luminance of a part of pixels of the transparent filter is not controlled in an independent manner appropriately, so that color purity (saturation) is degraded, and the image with a display color which is not intended, which is different from an original image is destined to be displayed.

Accordingly, the first object of the invention is to provide a RGBW type liquid crystal display apparatus capable of properly improving luminance of the image output from the liquid crystal panel by controlling luminance of the pixel of the transparent filter in an independent manner appropriately under a predetermined calculation when establishing luminance of the liquid crystal panel.

According to the liquid crystal display apparatus described in claim 1, said predetermined calculation processing by said data calculating means obtains said digital value for driving said luminance-intensifying subpixel by a function of $W=f(Y_{min}, Y_{max})$ in case where said digital value of said luminance-intensifying pixel is defined as W and Y_{min}

and Y_{max} of said digital values of each of said red inputting subpixel, said green inputting subpixel and said blue inputting subpixel are respectively defined as a minimum value and a maximum value, whereby said first object can be achieved.

According to the liquid crystal display apparatus described in claim 2, said
5 function of $W=f(Y_{min}, Y_{max})$ is directed to a function which is monotonously increased as said Y_{min} value or said Y_{max} value becomes larger, whereby said first object can be achieved.

According to the liquid crystal display apparatus described in claim 3, said
10 function of $W=f(Y_{min}, Y_{max})$ is directed to a function where said Y_{min} is a variable value and said Y_{max} is a constant value and a function which is monotonously increased as said Y_{min} value becomes larger, whereby said first object can be achieved.

According to the liquid crystal display apparatus described in claim 4, in a
15 case where α , β and n are predetermined real numbers and a maximum value which can be adopted regarding as said red inputting subpixel, said green inputting subpixel and said blue inputting subpixel, is defined as MAX , said function of $w=f(Y_{min}, Y_{max})$ being represented by a function of $W=Max*\{(Y_{min}+\alpha)+(MAX+\beta)\}^n$ by which a digital value for driving said luminance intensifying subpixel is obtained, whereby said first object can be achieved.

According to the liquid crystal display apparatus according to any of claims 1
20 and 4, in a case where a digital value of any of said red inputting subpixel, said green inputting subpixel and said blue inputting subpixel is directed to zero value, a value of said W is directed to zero value, whereby said first object can be achieved.

According to the liquid crystal display apparatus described in claim 6, said
apparatus comprises:

25 storing means for storing a plurality of kinds of functions represented by said function of $W=f(Y_{min}, Y_{max})$; and

selecting means for selecting any of said plurality of kinds of functions represented by said function of $W=f(Y_{min}, Y_{max})$ stored by said storing means, whereby said first object can be achieved.

According to the liquid crystal display apparatus described in claim 7, wherein
30 said red outputting subpixel, said green outputting subpixel and said blue outputting subpixel are constituted as a main pixel unit without using said subpixel for luminance, thereby to be able to use as a liquid crystal display apparatus capable of color-displaying, whereby the second object can be achieved.

According to the liquid crystal display apparatus described in claim 8, wherein it is made possible to perform an image display which said red outputting subpixel, said green outputting subpixel and said blue outputting subpixel are constituted as a main pixel unit without using said subpixel for luminance, and an image display which said red outputting subpixel, said green outputting subpixel and said blue outputting subpixel are constituted as a main pixel unit using said subpixel for luminance at same time, whereby the second object can be achieved.

These and other aspects of the invention are apparent from and will be elucidated with reference to the embodiments described hereinafter.

10

In the drawings:

Fig. 1 is a block diagram showing a constitution of a liquid crystal display apparatus 100 of a preferred embodiment according to the invention;

15

Fig. 2 is a top plane view for illustrating an arrangement of a subpixel, a gate bus, and a source bus of a liquid crystal panel 1 shown in Fig.1;

Fig. 3 is a block diagram schematically representing a source driver 3 and a decoder 6 shown in Fig.1;

20

Fig. 4 is a chromaticity diaphragm using to illustrate a mathematical formula 2;

Fig. 5 is a graph of a calculated result obtained by using a mathematical formula 3;

Fig. 6 is a top plane view showing a modification of an embodiment shown in Fig. 2;

25

Fig. 7 is a top plane view showing a modification of an embodiment shown in Fig. 2; and

Fig. 8 is a block diagram representing a modification of an embodiment shown in Fig. 3.

30

Fig. 1 is a block diagram showing a constitution of a liquid crystal display apparatus 100 of one first embodiment according to this invention. This liquid crystal display apparatus 100 is provided with a liquid crystal panel 1. Fig. 2 is a top plane view schematically showing a horizontal portion of this liquid crystal panel 1. This liquid crystal

panel 1 is provided with row-like gate buses G1 to Gm (m: a natural number) and column-like source buses S1 to Sn (n: a natural number) as shown in Fig. 2. Moreover, the gate buses G1 to Gm are connected with the gate driver 2, and the source buses S1 to Sm are connected with the source driver 3.

5 Moreover, subpixels Lij of R (red), G (green), B (blue) or W (white (for reinforcement of luminance)) are arranged in meshes which the gate bus Gi and G_{i+1} (i=1 to m) and the source bus Sj and S_{j+1} (j=1 to m) form.

10 Moreover, TFTs (thin film transistors) Qij are arranged in the vicinity of the intersections of the gate buses Gi and the source buses Sj. Furthermore, the gate bus Gi is connected with the gate of the TFT Qij, the source bus Sj with the source of TFTQij, and the display electrode of each subpixel Lij with the drain of the TFT Qij. Moreover, the electrode opposed to the display electrode of each subpixel Lij is a common electrode 12, and this common electrode 12 is connected with a voltage supply circuit (not shown).

15 Moreover, the color filter for the RGBW is arranged for each the subpixel Lij as follows, when the subpixels are arranged in a longitudinal stripe form as shown in Fig. 2 and one pixel is constituted from four subpixels of the RGBW.

R:Lij (i=1, 2, 3, ..., m-1, j=1, 5, 9, ..., n-3)

G:Lij (i=1, 2, 3, ..., m, j=2, 6, 10, ..., n-2)

B:Lij (i=1, 2, 3, ..., m, j=3, 7, 11, ..., n-1)

20 W:Lij (i=1, 2, 3, ..., m-1, j=4, 8, 12, ..., n)

In this liquid crystal panel 1, these subpixels form a longitudinal stripe arrangement.

25 Moreover, a TFT substrate on which the subpixel electrode is formed, a color filter substrate on which the common electrode is formed and a glass substrate or the like, which are not shown, are arranged in a direction perpendicular to a panel surface of the liquid crystal panel 1, and a liquid crystal is filled in such a manner as to be sandwiched between these substrates. In the color filter substrate, although the red, green and blue semitransparent color filters are arranged respectively at a part corresponding to the above-described subpixel RGB, the color filter is not arranged at a part corresponding to the subpixel W, or the
30 transparent filter is arranged.

Returning to Fig.1, the description of the liquid crystal display apparatus 100 will be continued. The Gate driver 2 and eight source drivers 3 are arranged around the liquid crystal panel 1. An amplifier, a DAC (a DA converter) and a latch, which are not shown, are arranged in each source driver 3. Moreover, this liquid crystal display apparatus 100 has a

signal control section 4. This signal control section 4 supplies a power supply voltage, as well as supplies control signals to the gate driver 2, the source driver 3, an image data holding section 5, and a decoder 6. The decoder 6 is connected with each source driver 3. Moreover, the image data holding section 5 in which each subpixel input data R_i , G_i , and B_i with eight bits of the red, green and blue colors of the image acquired in digitalized form are held is connected with this decoder 6.

Moreover, the liquid crystal display apparatus 100 comprises a reference potential generating circuit applying reference potential on the basis of a predetermined clock frequency to each source driver 3 (not shown).

10 The operation of the liquid crystal display apparatus 100 shown in Fig. 1 will be described below.

The control signal is supplied from the signal control section 4 to the gate driver 2 and each source driver 3. The gate driver 2 transmits a signal for turning TFTQ_{ij} into the on condition to each of gate buses (refer to Fig. 2) based on the control signal.

15 Moreover, subpixel outputting luminance data R_o , G_o , B_o and W_o of eight bits are latched in the latch portion (not shown) of each source driver 3 based on the control signal, when the control signal is supplied to each source driver 3.

Moreover, these subpixel outputting luminance data R_o , G_o , B_o and W_o of eight bits can be obtained as a result of performing the predetermined calculation (will be described later) by the decoder 6 for subpixel inputting data R_i , G_i , and B_i constituting the digital image which is held on the image data holding section 5.

Subpixel outputting luminance data R_o , G_o , B_o and W_o latched in the above-description latch portion are output in order and are input to the DAC portion (not shown). Moreover, the control power supply 4 outputs a polarity control signal for controlling whether the DAC portion selects potential from positive polarity reference potential generated from the reference potential generating circuit or selects potential from negative polarity reference potential, and this polarity control signal is input to the DAC portion. The DAC portion selects potential corresponding to these W subpixels outputting luminance data R_o , G_o , B_o and W_o from potential which is generated by the reference potential generating circuit based on the input polarity control signal and subpixel outputting luminance data R_o , G_o , B_o and W_o .

When potential is selected by the DAC portion, the DAC portion divides a voltage of the selected potential by resistance division into several steps appropriately so as to obtain a desired gradation. The divided voltage is current-amplified by an amplifier and

transmitted to a corresponding one of the source buses S1 to Sn (refer to Fig. 2). When the TFT becomes on by the signal transmitted to one of the gate buses G1 to Gm, this signal of the potential transmitted to this source bus is transmitted to each subpixel electrode by way of this TFT.

5 According to this operation, potential corresponding to subpixel outputting luminance data is added to each subpixel electrode. Therefore, a voltage is supplied to the liquid crystal layer which is sandwiched between a common electrode and each subpixel electrode, and the liquid crystal layer is driven in response to potential added to each subpixel electrode, so that the image is displayed on the liquid crystal panel 1 by principle of additive
10 color mixing.

 The preferred embodiment in relation to calculation processing of the decoder 6 mentioned above will be described with reference to Fig.3 in further detail below. The decoder 6 acquires each input subpixel digital data Ri, Gi, and Bi of the red, green and blue colors of eight bits from the image data holding section 5 to output RGBW subpixel
15 outputting luminance data Ro, Go, Bo and Wo from these Ri, Gi, and Bi to the source driver 3 as shown in Fig. 3.

 On the other hand, the following processing is required in order to obtain W subpixel outputting luminance data Wo.

 The decoder 6 is provided with a comparator 7 and a look-up table 8. The
20 comparator 7 converts this value into dimensions of luminance data after comparing values of input subpixel digital data Ri, Gi, and Bi acquired as described above to select a minimum value Ymin of the values of these Ri, Gi, and Bi.

 Next, the look-up table 8 converts the Ymin value thus selected and converted it into W subpixel outputting luminance data Wo by this comparator 7.

25 The conversion to W subpixel outputting luminance data Wo of the Ymin value described above can be realized easily by using PROM in which the calculated result of a mathematical formula 1 which is mentioned later, for each value of Ymin which changes from zero to 255 (in the case of 256-step gradation) is stored in a Ymin address. Furthermore, the control signal from the signal control section 4 to decoder 6 and memory or the like in
30 which data is stored are not required if being a circuit constitution for only this object.

 However, since a delay by some number of clocks is caused while the comparator and the look-up table outputs W subpixel outputting luminance data Wo after input subpixel data Ri, Gi, and Bi are input in the decoder 6, the long time can be required. At that time, output of RGB subpixel outputting luminance data Ro, Go and Bo is required to

be delayed within decoder 6 in synchronization with outputting of W subpixel outputting luminance data W_o .

As described above, the decoder 6 determines W subpixel outputting luminance data W_o from input subpixel data R_i , G_i , and B_i obtained from an input original image.

Furthermore, the above-mentioned mathematical formula 1 will be described. The mathematical formula 1 is an optional function which is represented by $W_o=f(Y_{min}, Y_{max})$, when W subpixel outputting luminance data is taken as W_o , and a minimum value is taken as Y_{min} , a maximum value is taken as Y_{max} of the digital values respectively for each of a red inputting pixel, a green inputting pixel, and a blue inputting pixel.

A function which is monotonously increased as said Y_{min} value or said Y_{max} value becomes larger can be adopted as the function which is represented by this mathematical formula 1. For example, it is the function of $W_o=(Y_{max} * Y_{min})/MAX^2$. Here, MAX is the largest value which can be taken, of the values of input luminance data of R_i , G_i and B_i .

Furthermore, $W_o=MAX*\{(MINRGB+\alpha)/(MAX+\beta)\}^n$ (hereinafter referred to this mathematical formula simply as a mathematical formula 2) is given as the other preferred examples of the mathematical formula 1. This mathematical formula 2 will be described in detail below. This mathematical formula 2 is the function in which a minimum value of RGB subpixel inputting luminance data which is output in the decoder 6 is defined as a variable, thereby to determine W subpixel outputting luminance data W_o .

In this mathematical formula 2, W_o is output luminance data for W subpixel, MAX is the largest value which can be taken, of the input luminance data value of R_i , G_i and B_i as is described above, and MINRGB is the minimum value which can be taken, of the input luminance data value of R_i , G_i and B_i . Moreover, α , β and n are optional real numbers.

The values of α , β and n are determined by optical characteristics such as luminance which is set as the target of the liquid crystal display apparatus 100. For example, the condition in which $\beta=0$ is obtained can be introduced from the condition in which W_o is made into MAX, that is, the condition that gives the largest luminance to the liquid crystal panel 1 of the liquid crystal display 100, when the minimum value MINRGB (Y_{min}) of input luminance data of R_i , G_i and B_i is MAX.

Moreover, the condition in which $\alpha=0$ and $\beta=0$ is obtained can be introduced from the condition that the contrast can not be degraded, which is concomitant with the liquid crystal display 100 inherently, since the condition in which W_o is made zero when the

minimum value MINRGB (Y_{min}) of input luminance data of R_i , G_i and B_i is zero, and the condition in which $W_o=MAX$ is obtained when the minimum value MINRGB (Y_{min}) of input luminance data of R_i , G_i and B_i is MAX, under this condition.

Optionally, when the color to be displayed for the liquid crystal display apparatus 100 is 256 step gradation, MAX value is MAX=255.

The calculation by the mathematical formula 2 also can be realized using the look-up table (LUT) which the decoder 6 comprises as described above. Such look-up table can be built-in ASIC of the decoder 6 easily, and can be realized easily with PROM and EEPROM which have a storage capacity of 256 byte when each input of RGBW and luminance data are of eight bits, such a look-up table. The values of α and β described above are set in the look-up table in advance in accordance with the optical characteristics (luminance) which are desired in the liquid crystal display apparatus.

Here, the theory which is founded at determining the mathematical formula 2 will be described with reference to a chromaticity diaphragm in Fig. 4 complementarily below.

Now, when R_i , G_i , and B_i and each point in R, G, B and W on the chromaticity diaphragm in Fig. 4 are in the following relationship, that is, the relationship that it corresponds to the point R when being $R_i=MAX$ and $G=B=0$, the point G when being $G=MAX$ and $R=B=0$, the point B when being $B=MAX$ and $R=G=0$, and furthermore, the point W when being $R_i=MAX$ and $R=G=B$ are satisfied, the following conclusion can be obtained. "When either of value of R, G and B is larger than zero, the chromaticity is inside the triangle RGB in Fig. 4." "Namely, the color is provided with a white (gray)-colored component, approaching the point W."

Furthermore, the following conclusion can be obtained with regard to W from the conclusion described above.

(1)"In the case of $R=G=B$, only luminance can be increased without change in chromaticity even though adding W thereto."

(2) "Since the triangle RGW represents the range of the color which the liquid crystal display apparatus can be expressed, $W=0$ is set, when at least any one of R, G and B is zero in order not to make this range narrow."

(3) "The chromaticity where either of R, G and B is larger approaches the point W as the minimum value of R, G and B becomes larger." "That is to say, the minimum value of R, G and B represents how the color is white." "Therefore, if W is given as the function of the minimum value of R, G and B, luminance can be increased without

excessively large changing the chromaticity where one pixel is constituted by three pieces of subpixel of R, G and B.”

Accordingly, the mathematical formula 2 which can give W as the function of the minimum value (MINRGB) of R, G and B could be derived in view of the conclusions of items (1), (2) and (3) described above.

Next, some embodiments (example 1 to 3) that the decoder 6 determines W_0 using this mathematical formula 2 will be described with reference to a graph of the mathematical formula 2 in Fig. 5 below.

Fig. 5 is a graph of the mathematical formula 2 in the case where the above-mentioned MINRGB value determined by the decoder 6 is taken as a variable of X axis, and W_0 value being determined by substituting the MINRGB value into the mathematical formula 2 is taken as a variable of Y axis, when the number of maximum gradation of each pixel of the display image is 256-step gradation.

As example 1, the case where any one of the values of luminance data of R_i , G_i and B_i is zero will be described. In this case, since MINRGB=0, $W_0=0$ is obtained from calculation of the mathematical formula 2 (on X axis of the graph in Fig. 5). Namely, $W_0=0$ can be designed to realize, whereby color purity (saturation) can not be reduced in this case.

As example 2, the case which $\alpha=\beta=0$ and $n=1$ are set in the mathematical formula 2 will be described. In this case, since the mathematical formula 2 is transformed into $W_0 = \text{MINRGB}$, the result which is represented by the straight line in Fig. 5 (example 2) can be obtained. Therefore, gamma(γ) characteristic of the original image before being input in the image data holding portion 5 can be held in this case. Moreover, the constitution of a circuit to be added is simple, and the scale of the constitution constituting the circuit also is needed in a small size.

As example 3, the case which “n” value is set larger than numerical value “1” in the mathematical formula 2 will be described. In this example 3, $n=2$ and $\alpha=\beta=0$ are set. Moreover, MAX=255 is set. From this setting, the mathematical formula 2 is represented with $W_0=255 * (\text{MINRGB}/255)^n$ (hereinafter referred to this mathematical formula as “a mathematical formula 3”), and this mathematical formula 3 is represented with the graph of Fig. 5 (example 3).

As understood from the graph of this (example 3), the W_0 value becomes larger suddenly as the MINRGB value is larger. That is to say, according to the calculation processing by this mathematical formula 2, a white display of approximately 100% to other display color can be realized in a glaring manner, since luminance (W_0) for W subpixel

becomes high suddenly, as MINRGB value approaches the maximum step number of gradation. As a result, radiance of a white cloud irradiated with the solar light which heretofore, has been realized by only CRT and, a display of a glittering luster of a metallic surface has come to be able to display.

5 Moreover, as understood from the graph of this (example 3), the graph of W_o is noticeable in the curved shape protruded downwardly (monotonously increased) in a variable region of the middle value which MINRGB value can take. As a result, luminance (W_o) for W subpixel can be suppressed in a halftone such as MINRGB=64 to 192, for example, and the original chromaticity (saturation) in the halftone can be held in the display
10 image.

As described above, various images becomes possible by defining a constant of the mathematical formula 2 as required according to said embodiments. It may be designed to select such that the image which an user desires can be obtained from the exterior by storing the functions such as examples 1 to 3 described above for determining W_o in a
15 plurality of pieces in the look-up table provided on the decoder 6 in advance.

As described above, according to said embodiments, appropriate W subpixel outputting luminance data can be determined in response to the image to be displayed by performing the calculation processing based on the mathematical formula 1 by the decoder 6. Moreover, the optical characteristics with various luminance desired in the liquid crystal
20 display apparatus 100 can be provided by setting various functions in the look-up table provided on the decoder 6 in advance.

Next, as mentioned above, the constitution that the liquid crystal panel 100 can be used also as the RGBW type liquid crystal display and also as the RGB type liquid crystal display will be described with reference to a block diagram in Fig. 6 in which the constitution
25 according to a block diagram in Fig. 3 is noted as a main part as a further embodiment.

A control signal C_i functioning as further one bit of switching control signal is added in addition to input signals R_i , G_i , and B_i in order to achieve this further embodiment, as shown in Fig. 6. This C_i signal is synchronized with clock frequency of the described-
above input signals R_i , G_i , and B_i , and all the circuit in Fig. 6 performing a function for
30 displaying RGBW is enabled, when this C_i signal is HIGH. On the other hand, CMP7 and LUT6 are skipped, $W_o=0$ is set, and the input signals R_i , G_i , and B_i are output as output signals R_o , G_o , and B_o as it is, when this C_i signal is LOW.

According to this operation, displaying of either of RGB display or RGBW display becomes possible by switching HIGH and LOW of the Ci signal. Moreover, it may be designed to set such that $W_o=0$ is set merely in LUT8, when RGB display is desired.

Switching of the Ci signal may be performed through software by the PC
5 which the liquid crystal display apparatus 100 is provided, or the switching may be designed to perform when pushing a short-cut-key or the like in a key board of the PC.

According to this operation, it can be used as the RGB type liquid crystal display apparatus since there is no necessity to brighten a white color in particular when preparing a text in an office work, on the other hand, it can be used as the RGBW type liquid
10 crystal display apparatus, when it is desired to highlight a snow scene, brightness of a car polished with a wax sufficiently, and a cloud, or a white-colored text such a telop for an advertisement.

A part thereof can display the screen for RGBW, and another part can display the screen for RGB by using a window of the screen of the PC. In this case, it is constituted
15 such that a pixel according to the Ci signal gives characterization on a pixel according to the input signals R_i , G_i , and B_i by each pixel unit, that is, the Ci signal can display the RGBW display at the pixel in the window screen of High and the Ci signal can display the RGB display at the pixel in the window screen of Low, for example. According to this constitution, for example, the screen which a luster obtained from a metallic surface of the car is
20 highlighted can be displayed at the window screen of the half of the right side and a text document which a profile or the like of the car is written can be displayed at the window screen of the half of the left side by providing the liquid crystal display apparatus according to the invention on the PC at a sales office and an exhibition of the car for the advertisement. The text document can be displayed on the other side by weakening the white color and to
25 make easy to read for observers rather than without highlighting a white color (luminance) so much, while taking advantage of a merit comprised in the RGBW screen.

Moreover, in the RGBW type liquid crystal display, an apparent difference in luminance of the white color where comparing with the RGB type liquid crystal display is recognized when observing the screen from a slightly distant position, whereby the RGBW
30 type liquid crystal display apparatus according to the invention can show noticeable effects in the case that the observer observes a white-colored character such as a telop with the RGBW type liquid crystal display apparatus from a distant position, at the crowded exhibition, and the case or the like that the observer should observe the RGBW type liquid crystal display

from a distant position inevitably, which is provided on a wall surface or the like of a building.

Moreover, the inventions described in each claim should not be limited to each embodiment mentioned above, and various modifications can be adopted within the scope described in each claim as described below.

Some modifications will be described below.

(1) Modification 1: although in a preferred embodiment, subpixel RGBW has been aligned in the form of longitudinal stripe arrangement as shown in Fig. 2, it may be aligned in a form of a mosaic-shape as shown in Fig. 6. In this case, an individual form of the subpixel is approximately square.

(2) Modification 2: although in the described-above modifications 1, meshes of a net are formed by the source buses and the gate buses and, the individual subpixel is made to arrange in the meshes of the net one by one as shown in Fig.7, the gate bus may be wired by one piece every two steps of the subpixel, the source bus may be wired by two pieces between one step of subpixel as shown in Fig.7. According to such constitution, the number of the gate bus is the same as the prior RGB type, and a writing characteristic of the TFT would remain as it is the prior art. Moreover, according to the constitution, it has become unnecessary to sort a source signal every one row in the source driver 3, since a color of the subpixel which is connected with a piece of source bus becomes one kind.

(3) Modification 3: although the decoder 6 and the source driver 3 are formed as separated bodies as shown in Fig.3 in the described-above preferred embodiment, these may be arranged as an integrated structure of the decoder and the source driver by arranging the decoder in an entrance portion of the inside of the source driver, as shown in Fig.9. According to such constitution, an increase by the amount corresponding to luminance data for W subpixel in the number of data wiring in the printed circuit board can be avoided.

As described above, according to the liquid crystal display apparatus of this invention, luminance of the image displayed with the liquid crystal panel can be improved appropriately.

CLAIMS:

1. A liquid crystal display apparatus capable of color-displaying provided with crystal panel having, in each main pixel unit, a red outputting subpixel, a green outputting subpixel, a blue outputting subpixel and a luminance-intensifying subpixel characterized by comprising:

5 data calculating means for obtaining a digital value for driving a luminance-intensifying subpixel by carrying out a predetermined calculation processing using digital values respectively for a red inputting pixel, a green inputting pixel, and a blue inputting pixel which are obtained from an input image,

wherein said liquid crystal displaying apparatus driving the luminance-intensifying subpixel, the red outputting subpixel, the green outputting subpixel and the blue outputting subpixel by using said digital value for driving said luminance-intensifying subpixel obtained by said data calculating means and said digital values of said red, green and blue inputting subpixels, characterized in that: said predetermined calculation processing by said data calculating means obtains said digital value for driving said luminance-intensifying subpixel by a function of $W=f(Y_{\min}, Y_{\max})$ where said digital value of said luminance-intensifying pixel is defined as W , and a minimum value and a maximum value of said digital values of said red inputting subpixel, said green inputting subpixel and said blue inputting subpixel are respectively defined as Y_{\min} and Y_{\max} .

20 2. A liquid crystal display apparatus according to Claim 2, wherein said function of $W=f(Y_{\min}, Y_{\max})$ is directed to a function which is monotonously increased as said Y_{\min} value or said Y_{\max} value becomes larger.

3. A liquid crystal displaying apparatus according to Claim 1 characterized in that: said function of $W=f(Y_{\min}, Y_{\max})$ is directed to a function in which said Y_{\min} is a variable value and said Y_{\max} is a constant value and which is monotonously increased as said Y_{\min} value becomes larger.

4. A liquid crystal display apparatus according to any of Claims 1 and 3 characterized in that: when α , β and n are predetermined real numbers and when a maximum value which digital values of said red inputting subpixel, said green inputting subpixel and said blue inputting subpixel can take is defined as MAX, said function of $w=f(Y_{\min}, Y_{\max})$ is represented by a function of $W=\text{Max}*\{(Y_{\text{miu}}+\alpha)+(MAX+\beta)\}^n$ by which a digital value for driving said luminance intensifying subpixel is obtained.
5. A liquid crystal displaying apparatus according to any one of Claims 1 to 4 characterized in that: when a digital value of any of said red inputting subpixel, said green inputting subpixel and said blue inputting subpixel is a zero value, a value of said W is zero.
6. A liquid crystal display apparatus according to any one of Claims 1 to 5 characterized in that: said apparatus comprises:
storing means for storing a plurality of kinds of functions each represented by said function of $W=f(Y_{\min}, Y_{\max})$; and
selecting means for selecting any of said plurality of kinds of functions represented by said function of $W=f(Y_{\min}, Y_{\max})$ stored by said storing means.
7. A liquid crystal display apparatus according to any one of claims 1 to 6, wherein said red outputting subpixel, said green outputting subpixel and said blue outputting subpixel are arranged to form a main pixel unit without using said subpixel for luminance in accordance with a predetermined control signal, thereby to enable the apparatus to be used as a liquid crystal display apparatus capable of color-displaying.
8. A liquid crystal display apparatus according to any one of claims 1 to 6, wherein it is made possible based on a predetermined control signal to perform an image display in which said red outputting subpixel, said green outputting subpixel and said blue outputting subpixel are arranged as a main pixel unit without using said subpixel for luminance, and at the same time an image display in which said red outputting subpixel, said green outputting subpixel and said blue outputting subpixel are arranged as a main pixel unit using said subpixel for luminance.

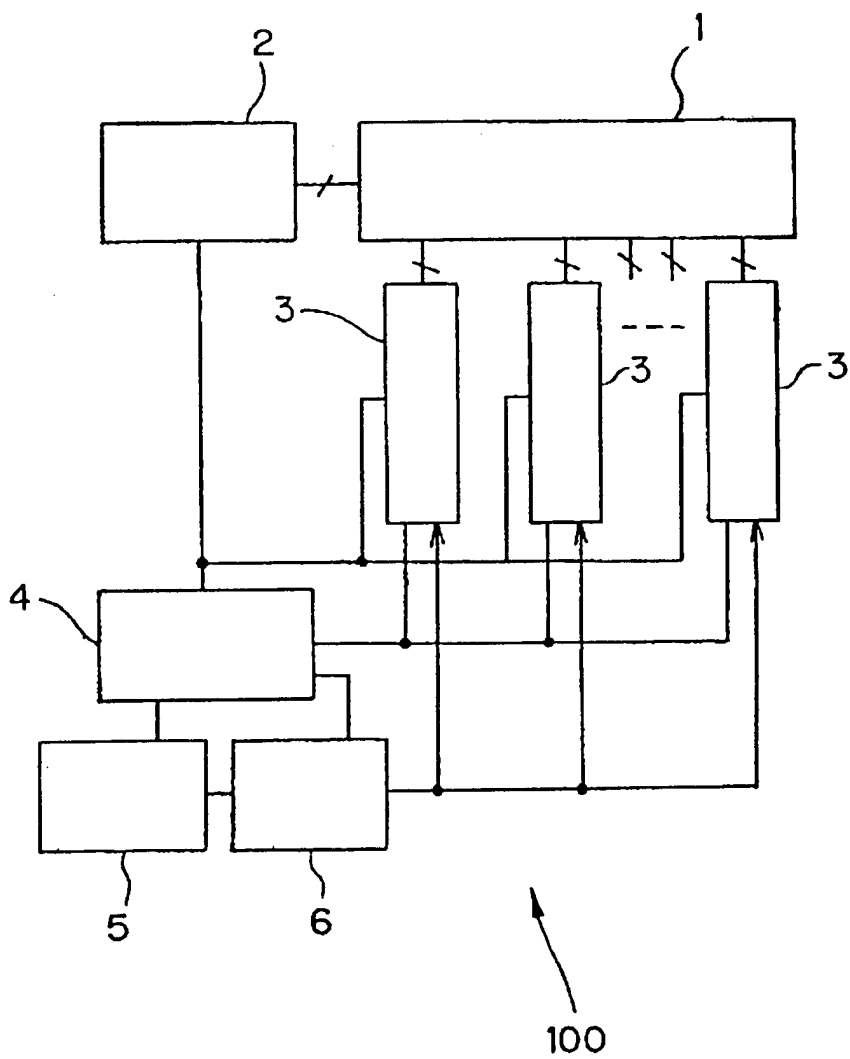

FIG. 1

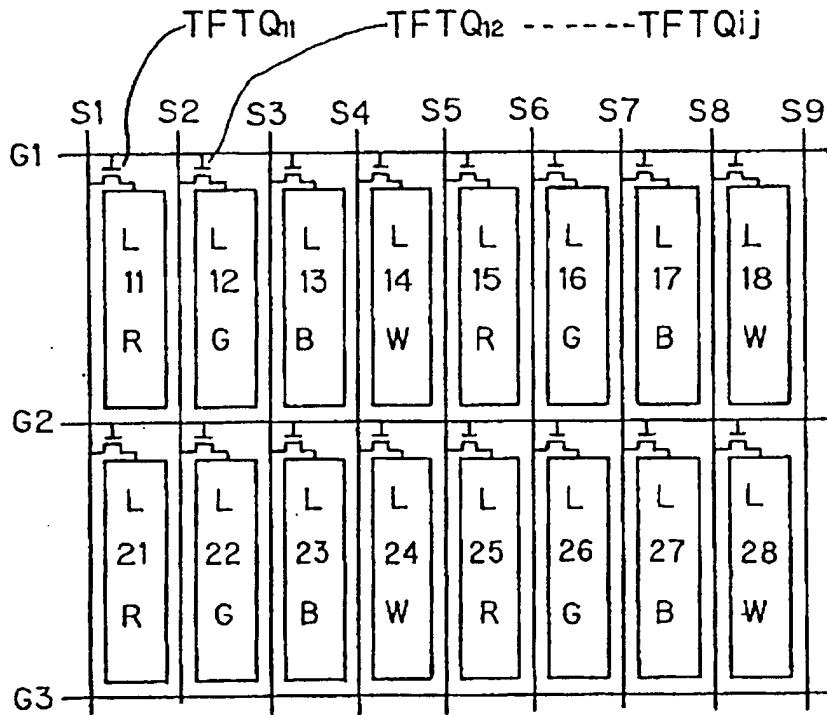

FIG. 2

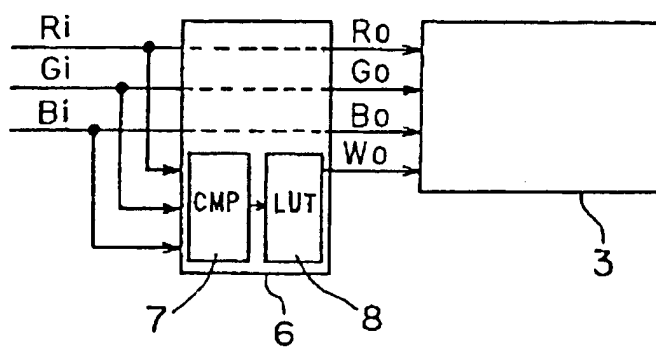

FIG. 3

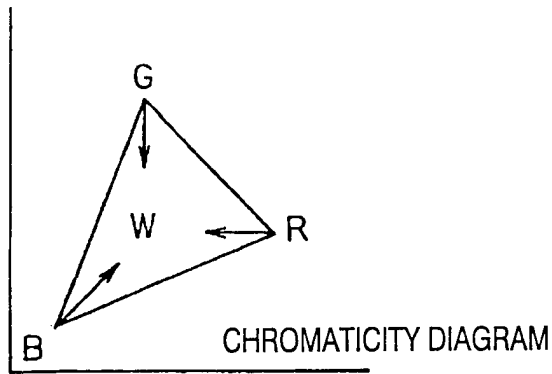

Fig. 4

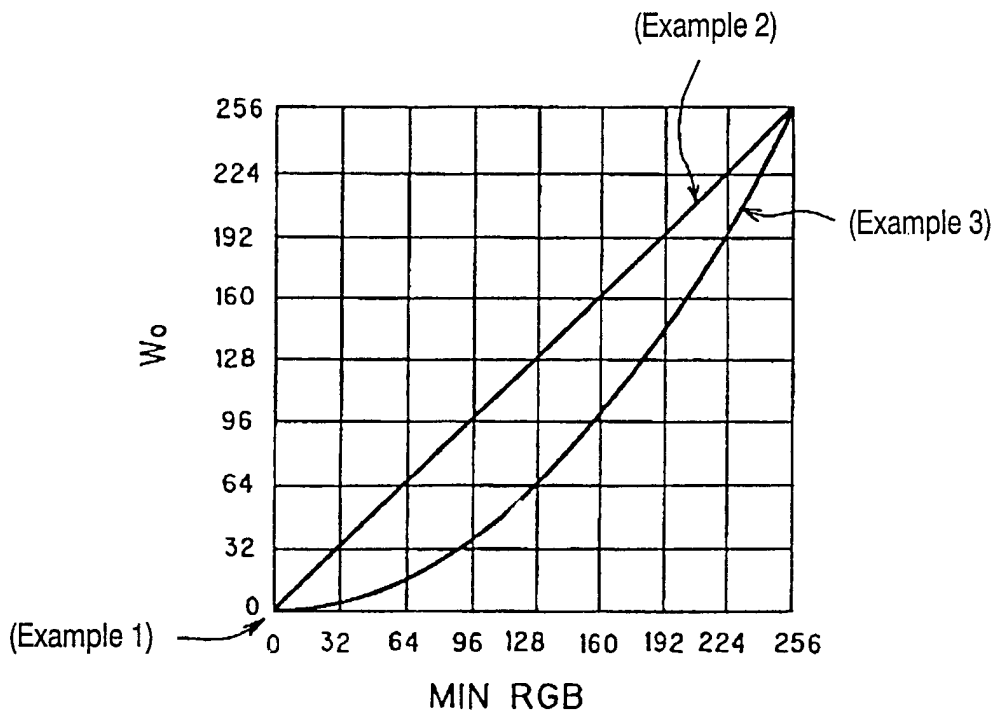

Fig. 5

4/5

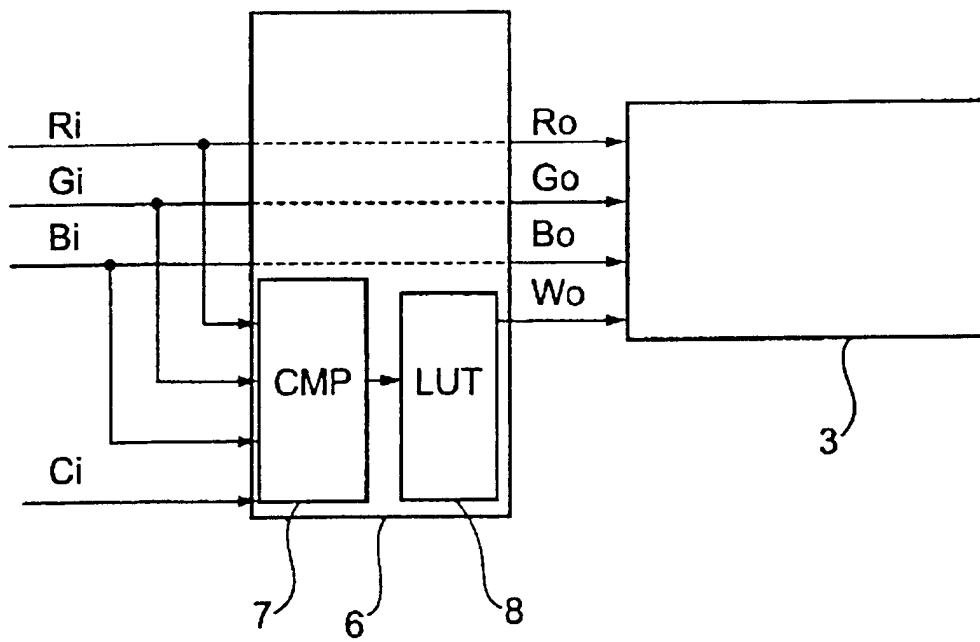

FIG. 6

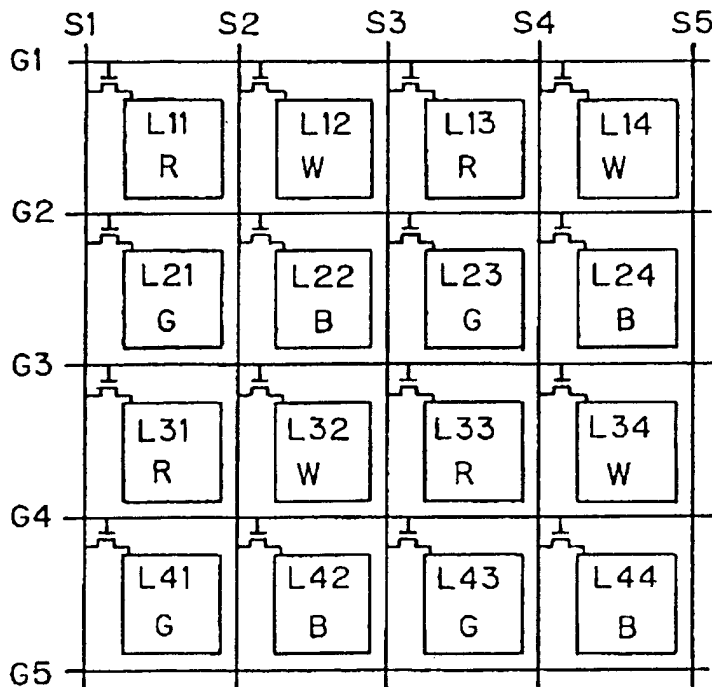

FIG. 7

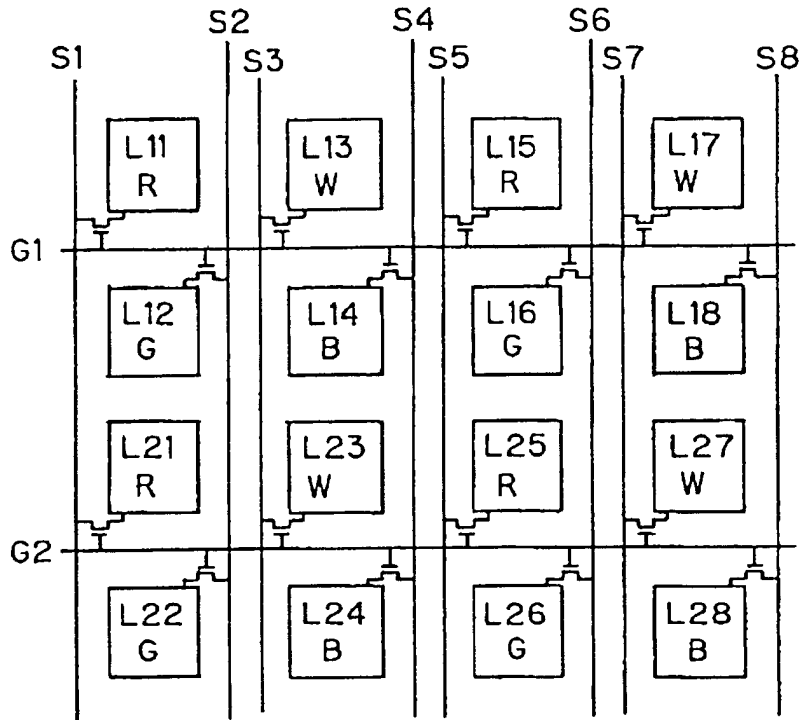

FIG. 8

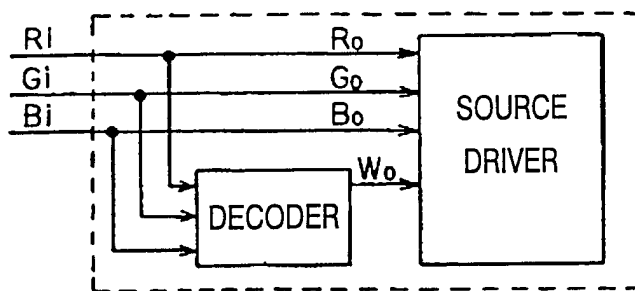

FIG. 9

INTERNATIONAL SEARCH REPORT

International Application No

PCT/EP 00/11288

A. CLASSIFICATION OF SUBJECT MATTER

IPC 7 G09G3/36

According to International Patent Classification (IPC) or to both national classification and IPC

B. FIELDS SEARCHED

Minimum documentation searched (classification system followed by classification symbols)

IPC 7 G09G

Documentation searched other than minimum documentation to the extent that such documents are included in the fields searched

Electronic data base consulted during the international search (name of data base and, where practical, search terms used)

EPO-Internal, WPI Data, PAJ

C. DOCUMENTS CONSIDERED TO BE RELEVANT

Category °	Citation of document, with indication, where appropriate, of the relevant passages	Relevant to claim No.
X A	EP 0 541 295 A (CANON KK) 12 May 1993 (1993-05-12) page 6, line 16 -page 9, line 45 -----	1-3,5,6 4

Further documents are listed in the continuation of box C.

Patent family members are listed in annex.

° Special categories of cited documents :

- *A* document defining the general state of the art which is not considered to be of particular relevance
- *E* earlier document but published on or after the international filing date
- *L* document which may throw doubts on priority claim(s) or which is cited to establish the publication date of another citation or other special reason (as specified)
- *O* document referring to an oral disclosure, use, exhibition or other means
- *P* document published prior to the international filing date but later than the priority date claimed

- *T* later document published after the international filing date or priority date and not in conflict with the application but cited to understand the principle or theory underlying the invention
- *X* document of particular relevance; the claimed invention cannot be considered novel or cannot be considered to involve an inventive step when the document is taken alone
- *Y* document of particular relevance; the claimed invention cannot be considered to involve an inventive step when the document is combined with one or more other such documents, such combination being obvious to a person skilled in the art.
- * & * document member of the same patent family

Date of the actual completion of the international search

26 February 2001

Date of mailing of the international search report

05/03/2001

Name and mailing address of the ISA

European Patent Office, P.B. 5818 Patentlaan 2
NL - 2280 HV Rijswijk
Tel. (+31-70) 340-2040, Tx. 31 651 epo nl,
Fax: (+31-70) 340-3016

Authorized officer

Amian, D

INTERNATIONAL SEARCH REPORT

Information on patent family members

International Application No

PCT/EP 00/11288

Patent document cited in search report	Publication date	Patent family member(s)	Publication date
EP 0541295 A	12-05-1993	CA 2081643 A	08-05-1993
		DE 69226689 D	24-09-1998
		DE 69226689 T	28-01-1999
		JP 5241551 A	21-09-1993
		US 5929843 A	27-07-1999

专利名称(译)	具有高亮度的液晶显示装置		
公开(公告)号	EP1147509A1	公开(公告)日	2001-10-24
申请号	EP2000974538	申请日	2000-11-10
[标]申请(专利权)人(译)	皇家飞利浦电子股份有限公司		
申请(专利权)人(译)	皇家飞利浦电子N.V.		
当前申请(专利权)人(译)	皇家飞利浦电子N.V.		
[标]发明人	HIRANO SATOSHI YASUI MASARU KAMIYA TAKEO SHUJI HAGINO		
发明人	HIRANO, SATOSHI YASUI, MASARU KAMIYA, TAKEO SHUJI, HAGINO		
IPC分类号	G09G3/36		
CPC分类号	G09G3/3607 G09G2300/0452		
优先权	1999321902 1999-11-12 JP 2000330859 2000-10-30 JP		
外部链接	Espacenet		

摘要(译)

RGBW型LCD本发明涉及一种RGBW型LCD，其中可以利用解码器根据预定的计算显示适当的发光图像，其中嵌入了一些预定的计算公式。此外，不仅RGBW图像显示而且RGB图像显示可以由预定的控制信号使用。