



(11) **EP 2 234 099 A1**

(12) **EUROPEAN PATENT APPLICATION**

(43) Date of publication:
29.09.2010 Bulletin 2010/39

(51) Int Cl.:
G09G 3/36^(2006.01)

(21) Application number: **09166227.0**

(22) Date of filing: **23.07.2009**

(84) Designated Contracting States:
AT BE BG CH CY CZ DE DK EE ES FI FR GB GR HR HU IE IS IT LI LT LU LV MC MK MT NL NO PL PT RO SE SI SK SM TR
 Designated Extension States:
AL BA RS

(71) Applicant: **Hannstar Display Corp.**
Taipei City 114, Taiwan (CN)

(72) Inventor: **Cheng, Chien-Yung**
Taipei City 114 (TW)

(30) Priority: **27.03.2009 TW 98110246**

(74) Representative: **Viering, Jentschura & Partner**
Grillparzerstrasse 14
81675 München (DE)

(54) **Liquid crystal display and power saving method thereof**

(57) The embodiments of the present invention disclose Liquid Crystal Display having low power consumption. Under the normal operation, a plurality of data voltages are inputted to a display panel having a constant frame rate, and an idle detecting step is performed to determine whether changes occur in the frame data voltages. When a percentage of the plurality of data voltages are unvaried after a specific period of time, the frame rate is reduced.

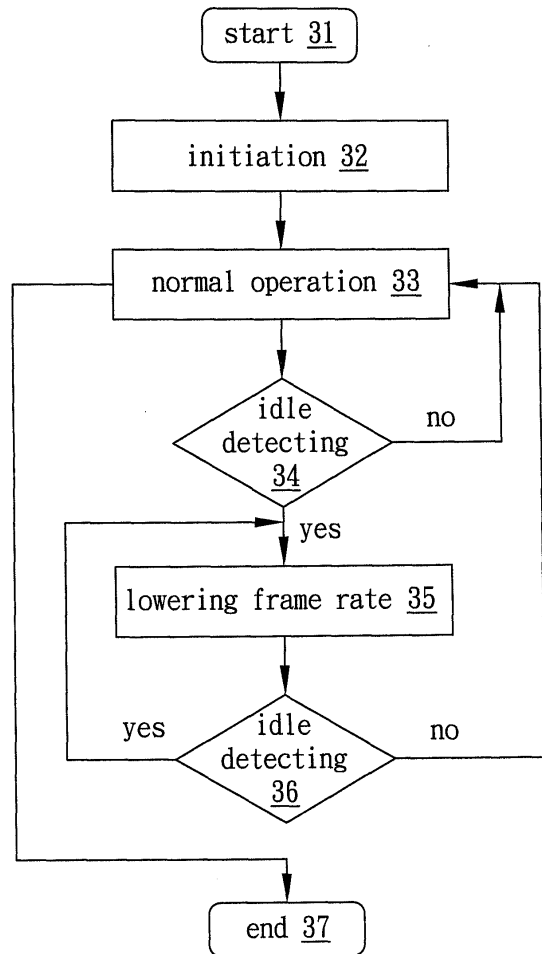

FIG. 3

EP 2 234 099 A1

Description**FIELD OF THE INVENTION**

[0001] The present invention relates to a Liquid Crystal Display, and more particularly, to a Liquid Crystal Display capable of lowering power consumption under the normal operation.

DESCRIPTION OF THE PRIOR ART

[0002] Lowering power consumption is always an important issue for Liquid Crystal Displays (LCD) such as LCD Television, LCD monitor, digital photo frame, and the likes. The power-conserving methods may comprise turning off the power of the screen, the power of the back-light module, and the power of idle devices of the Liquid Crystal Display.

[0003] Altering the driving method or driving structure of Liquid Crystal Displays may also achieve the purpose of low power consumption. Figure 1 shows a conventional driving structure of Liquid Crystal Display, which comprises a display panel 10 having a pixel array, a gate driver 12 for driving gate lines G0-Gn, a data driver 14 for driving data lines D1-Dm, and a timing controller 16 for driving the gate driver 12 and the data driver 14. In addition, each pixel of the pixel array comprises a transistor 18, a storage capacitor C_{st} , and a liquid crystal capacitor C_{LC} .

[0004] Although many power-conserving methods by altering the driving method or driving structure of Liquid Crystal Displays are practicable, the power consumption is still high when the Liquid Crystal Display is under non-power-conserving mode, i.e. under normal operation. For example, the Liquid Crystal Display typically has a constant frame rate under normal operation. The frame rate is typically shown by unit of fps (frames per second) or Hz (hertz) and in general, the liquid crystal display usually has a constant frame rate at 60 Hz or 180 HZ. Figure 2 illustrates two data voltages having different polarity being written to two pixels for displaying a frame. Under normal operation, gate line G0 provides a voltage to open a transistor 18, so that a positive or a negative data voltage is written to a pixel of a specific position via a data line. For example, a positive data voltage is written to the left pixel via the data line D1 and a negative data voltage is written to the right pixel via the data line D2 as shown in figure 2. The value of the voltage written to the pixel depends on the video content of the frame. If a Liquid Crystal Display has a constant frame rate at 60 Hz, the period of one frame will be $1/60=16.67$ ms. Hence each pixel of each row of the pixel array must be charged once per 16.67 ms, and each pixel must be charged 60 times per second. The charging frequency is high and the written data voltages cannot be altered because it relate to the video content of the frame; therefore, the power consumption is high when the Liquid Crystal Display is under normal operation according to the prior arts.

[0005] Therefore, it would be advantageous to provide a better power-conserving method and device to improve the deficiencies of prior art.

5 SUMMARY OF THE INVENTION

[0006] The object of the present invention is to provide a better power-conserving method and device that is capable of lowering power consumption under the normal operation.

[0007] According to the object, the embodiments of the present invention provide a Liquid Crystal Display and its driving method. The Liquid Crystal Display comprises a display panel and a timing controller, the timing controller controlling the display panel and executing the driving method. The method comprises: executing a normal operation, the processor outputting a plurality of control signals to a data driver, the data driver outputting a plurality of data voltages to the display panel via a plurality of data lines, the Liquid Crystal Display being displayed at a constant initial frame rate; and executing an idle detecting step to check whether an idle event is met or executing a first manipulation detecting step to check whether a manipulation event is met, when a percentage or more of the plurality of data voltages are unchanged after a period of time, or when a manipulation event is met and the manipulation event selects a specific display mode, the initial frame rate is decreased to a first frame.

30 BRIEF DESCRIPTION OF THE DRAWINGS**[0008]**

Figure 1 shows a conventional driving structure of Liquid Crystal Display according to the prior art.

Figure 2 illustrates two data voltages having different polarity being written to two pixels for displaying a frame according to the prior art.

Figure 3 discloses a driving method of a Liquid Crystal Display according to an embodiment of the present invention.

Figure 4 shows a driving method according to another embodiment of the present invention.

Figure 5 shows a driving method according to another embodiment of the present invention.

Figure 6 illustrates the operation of the driving method according to an embodiment of the present invention.

Figure 7 shows a block diagram of a Liquid Crystal Display according to one embodiment of the present invention.

Figure 8 shows a Liquid Crystal Display according to another embodiment of the present invention.

Figure 9 shows the frequency of the control signal will be decreased as well when the frame rate is decreased as in figure 7 or figure 8.

Figure 10 and Figure 11 illustrate that when the frame rate is decreased, the adapted adjustments of the control signal according two embodiments of the present invention.

DESCRIPTION OF THE PREFERRED EMBODIMENT

[0009] Reference will now be made in detail to specific embodiments of the invention. Examples of these embodiments are illustrated in accompanying drawings. While the invention will be described in conjunction with these specific embodiments, it will be understood that it is not intended to limit the invention to these embodiments. On the contrary, it is intended to cover alternatives, modifications, and equivalents as may be included within the spirit and scope of the invention as defined by the appended claims. In the following description, numerous specific details are set forth in order to provide a through understanding of the present invention. The present invention may be practiced without some or all of these specific details. In other instances, well-known process operations are not been described in detail in order not to unnecessarily obscure the present invention. While drawings are illustrated in details, it is appreciated that the quantity of the disclosed components may be greater or less than that disclosed, except expressly restricting the amount of the components. Wherever possible, the same or similar reference numbers are used in drawings and the description to refer to the same or like parts.

[0010] In the field of displays, displaying the video signal in a high frame rate is increasingly necessary for present displays such as Liquid Crystal Display; however, the inventor of the present invention observes that a lower frame rate will be satisfied in some situations under the normal operation, and the constant high frame rate may be unnecessary.

[0011] Accordingly, the present invention discloses methods and devices that are capable of dynamically changing the frame rate, in which the frame rate is changed according the video content or the user's operation; hence the objective of low power consumption can be achieved.

[0012] Figure 3 discloses a driving method of a Liquid Crystal Display according to an embodiment of the present invention. The Liquid Crystal Display comprises a processor (not shown) for outputting control signals and controlling the frame rate. The processor executes the driving method for determining the time that the frame rate will be changed. At step 31, the method is started. At step 32, the Liquid Crystal Display is initiated. For ex-

ample, but not limited, before the normal operation an Optically Compensated Birefringence Liquid Crystal Display must transform some of the liquid crystal molecules from the splay state to the bend state at the initiation step.

At step 33, a normal operation is started. In this step, the Liquid Crystal Display may be displayed at a constant frame rate, for example, a predetermined initial frame rate at 60 Hz or 120 Hz. At step 34, an "idle detecting" step is performed to check whether an "idle" event is happened, wherein the idle is defined as when a percentage (for example, 55%) or more of the plurality of data voltages written to the pixel array by the plurality of data lines are unchanged after a predetermined or automatically set up period of time. For, example, a Liquid Crystal Display has 1024×768 pixels, therefore having $1024 \times 3 = 3072$ data lines. Under the normal operation, if 1689 data voltages (about 55% of 3072) of the 3072 data voltages are unchanged after a period of time T, an idle event is met. According to the embodiment of the present invention, the period of time T is longer than the period of one frame. Preferably, the period of time T may be ranged from 1 to 5 seconds, but this should not be limited. At step 35, if an idle event is met, the initial frame rate is decreased to a first frame rate to lower the power consumption. If an idle event is not met, the frame rate is kept the same as the initial frame rate. At step 36, the "idle detecting" step is performed again to check whether another "idle" event is happened. If another idle event is met, the first frame rate may be changed to a second frame rate, wherein the second frame rate may be equal to, larger than, or smaller than the first frame rate according to the extent of the idle or according to the video content. That is, if the current video content needs a higher frame rate, the second frame rate may be larger than the first frame rate. If a lower frame rate satisfies the current video content, the second frame rate may be smaller than the first frame rate. If another idle event is not met, back to the normal operation 33, that is, the frame rate is increased to the initial frame rate. At step 37, the driving method is ended. Typically the driving method is ended by receiving an ending demand at the normal operation 33, but this should not be limited.

[0013] In the above-mentioned steps, the initial frame rate may be decreased to the first frame rate or even decreased to the second frame rate. The value of first frame rate and second frame rate is not limited, and they may be minimized to an condition that the Liquid Crystal Display has no flicker; otherwise the viewer will aware it. Hence the frame rate may be decreased to a lower limit value that is the minimized value under the condition that the Liquid Crystal Display has no flicker. The lower limit value regards with the manufacturing method, process capability, and kinds of the Liquid Crystal Display. In addition, in one embodiment, the idle percentage of the plurality of data voltages is preferably defined as 50%, 55% or more of the data voltages.

[0014] Many situations may satisfy the idle event. For example, when the Liquid Crystal Display is employed in

a department store for displaying an advertisement, the update frequency of the image of the advertisement may be low. Hence the frame rate may be decreased when the advertisement is displaying and an idle event is met. For example, when the Liquid Crystal Display is employed for displaying television news, the lips of the anchor is the only varied portion of the television news in a period of time; therefore this situation may satisfy the definition of idle event. For example, when the Liquid Crystal Display is employed as a photo digital frame, the update frequency of photo may be low, and the period of time that the current photo is not yet changed probably meets the definition of idle event. In summary, the inventive concept of the embodiments of the present invention determine whether the frame rate is changed according to whether the current video content meet the definition of idle event.

[0015] Figure 4 shows a driving method according to another embodiment of the present invention. This embodiment is a modification of the embodiment shown in figure 3; the difference is that the driving method further comprises a "manipulation detecting" step 38 before the idle detecting step 33. The manipulation detecting step 38 checks whether a manipulation event is induced by the user. If a manipulation event is met, then backs to step 35 or step 33 according to the manipulation event. If a manipulation event is not met, then performs the idle detecting step 36. This embodiment may be applied to a Liquid Crystal Display having variant manipulative display mode, such as photo mode, video mode, MP3 mode, TV game mode, and the like. Each display mode may be corresponding to a predetermined frame rate, and these frame rates may be equal to or smaller than the frame rate under normal operation, i.e., the initial frame rate. Therefore when the user selects a display mode, the current frame rate will be changed to the initial frame rate (step 33) or kept at lower frame rate (step 35) according to the video content of the display mode that the user selected. In another embodiment, when the user selects a display mode, the current frame rate will be changed to the initial frame rate (step 33) or kept at lower frame rate (step 35) according to the display mode that the user selected. In another embodiment of the present invention, if a manipulation event is met, then backs to the normal operation 33 and the frame rate is dominated by the user. For example, the user selects a specific display mode and determines a specific frame rate or the display actively adopts a specific frame rate which is set up inside the display mode. When the user controls the frame rate, the steps 34, 35, 36, and 37 are standby until a predetermined time has passed and the user has no further action or the user actively makes a demand to request the idle detecting step 34 to be restarted again. In addition, the embodiment of figure 4 may omit the idle detecting step 36; at this case, when a manipulation event is not event, the Liquid Crystal Display will display at the first frame rate or the second frame rate until the process end 37.

[0016] Figure 5 shows another embodiment of the present invention in which a manipulation detecting step 39 and a "whether the manipulation event is a specific mode" step 40 have replaced the idle detecting step 34 mentioned above. In this embodiment, the steps after the "lowering frame rate" step 35 may be the same as embodiment of figure 3, figure 4, and modification of them; therefore the description is omitted for simplicity. At step 39, if a manipulation event is met under the normal operation 33, it indicates that the user may select a display mode. At step 40, the processor checks whether the manipulation event is a specific display mode. The specific display mode is defined as the video content of which can be displayed in a lower frame rate, such as the photo mode and the MP3 mode. If the user selects one specific display mode, then the step 35 "lowering the frame rate" is performed, otherwise backing to normal operation 33. It is appreciated that the "manipulation detecting" step 38/39 of figures 4 and 5 are not limited in situation that the user selects or alters the display mode; any event induced by the user, for example, in an embodiment, touching the screen of the display and pressing a specific key, may be corresponding to specific frame rate respectively, and then the processor changes the frame rate accordingly.

[0017] Figure 6 illustrates the operation of the driving method according to an embodiment of the present invention. This exemplary embodiment is shown for purpose of illustration; it should not be limited. Under the normal operation, the frame rate of Liquid Crystal Display may be fixed at 60 Hz. When the current video content satisfies the definition of idle event, the frame rate may be lowered to 50 Hz or 40 Hz; when a higher frame rate is necessary for the current video content, the frame rate is increased to back to the normal operation. According to the driving method of the present invention, the frame rate can be dynamically decreased, hence the charging frequency (no matter positive or negative voltage) of liquid crystal capacitor C_{LC} and thus the power consumption being decreased as well.

[0018] Figure 7 shows a block diagram of a Liquid Crystal Display according to one embodiment of the present invention. The Liquid Crystal Display 61 comprises a timing controller 62, a display panel 63, a first memory 64, and a second memory 65. The first memory 64 and the second memory 65 are employed for storing image data. In one embodiment, the first memory 64 comprises NAND flash, and the second memory comprises Synchronous Dynamic Random Access Memory (SDRAM). The timing controller 62 may correspond to the processor as mentioned in description of figure 3.; it is employed for executing the driving method of the present invention and outputting control signal for controlling the display panel 63. The timing controller 62 respectively access image data via Clock 1, Clock 2, and Data Bus. It is appreciated that this exemplary embodiment includes two memories, but it should not be limited. In another embodiment, the Liquid Crystal Display may

comprise only one memory, for example, only a SDRAM, and the timing controller 62 access the image data from the SDRAM. In another embodiment, the Liquid Crystal Display may connect to an external data-storing device, such as a DVD-ROM, and access image data from the external data-storing device. According to the driving method of the embodiments of the present invention, the frame rate can be dynamically adjusted. When the frame rate is decreased, it means that the updating frequency of the plurality data voltages of the data lines are decreased as well; therefore, the accessing frequency of the timing controller 66 accessing the memory or external data-storing device through the signal Clock 1, Clock 2, and Data Bus can be decreased as well. Hence the power consumption for accessing the image data can also be correspondingly decreased and the objective of low power consumption can be achieved.

[0019] In addition, the timing controller 62 may control the display panel 63 by any well-known method, such as the method described in figure 1. For example, the timing controller 65 outputs control signal to a gate driver and a data driver for controlling the display panel 63. The gate driver and source driver may comprise a plurality of gate driving chips and a plurality of data driving chips respectively. In another embodiment of the present invention, the timing controller 62 may provide control signal to the source driver only, and then the source driver outputs control signal to the gate driver. In another embodiment, the driving system comprises two gate drivers, that is, a double gate driver design is also acceptable in the present invention.

[0020] Figure 8 shows a Liquid Crystal Display according to another embodiment of the present invention. This embodiment differs from the embodiment of figure 7 in that the duty of the first memory 64 and the second memory 65 are incorporated into the timing controller 72 or a processor 73, and the processor 73 is responsible for executing the driving method of the present invention and controlling the display panel 63 by the timing controller 72. Although variant modifications are adapted in the present invention, the principle of lowering the power consumption is the same. As embodiments described above, the timing controller, the independent processor, or any other controllers of the display may execute the driving method of the present invention.

[0021] Figure 9 shows the frequency of the control signal will be decreased as well when the frame rate is decreased as in figure 7 or figure 8. In other words, the charging frequency of liquid crystal capacitor C_{LC} is also decreased, hence the charging numbers being reduced in a same period of time; therefore, the objective of low power consumption can be achieved. For example, suppose that one Liquid Crystal Display has 1024×600 pixels, when the frame rate is 60 Hz, the frequency of the Driving Clock (Dclock) and Data are 43.75 MHz. When the frame rate is decreased to 50 Hz, the frequency of the DClock and Data are adaptively decreased to 36.5 MHz. Because the frame rate is decreased, the updating

frequency of the DClock and Data are unnecessary to be maintained at high frequency, so that the frequency is decreased from 43.75 MHz to 36.5 MHz, and therefore the frequency of Clock and Clock 2 shown in figure 7 may be decreased in a correspond manner. Accordingly, the power consumption of the accessing activities can be significantly reduced. Similarly, when the frame rate is decreased to 40 Hz, the DClock and Data is adaptively decreased to 29.25 MHz, and the control signal Clock 1/Clock 2 (as shown in FIG.7) can be adaptively decreased as well; therefore the objective of the low power consumption can be achieved.

[0022] Figure 10 and Figure 11 illustrate the detail of that when the frame rate is decreased, the adapted adjustments of the control signal according two embodiments of the present invention. These two figures illustrate that how the charging frequency of the liquid crystal capacitor C_{LC} is affected by the driving method of the present invention. Generally, the control signals for controlling the display panel are divided into gate control signals and source control signals. The gate control signals may comprises, but not be limited, Gate Driver Start Signal (STV), Gate Clock Signal (GCK), and Gate Driver Output Enable Signal (OE). The source control signals may comprise Source Driver Start Signal (STH), Data Enable Signal (DE), and Load Signal (Load). Other signals not being shown may comprise Data Clock Signal (having same wave as the DE signal) and Polarity Control Signal. The functions of the above control signals are well known in the field of display device; therefore the description of which are omitted for simplicity. Referring to figure 10 first, which shows the additional adaptive adjustment of the data control signals and the source control signals in addition to the frequency change shown in figure 9. As shown in figure 10, each control signal includes a predetermined number of activity periods (an activity period is denoted by 1H) during one frame, where one activity period may comprise a pull high event and a pull low event. According to embodiment of figure 10, when frame rate is decreased, the period of one frame is adaptively increased, for example, the period of one frame being increased from 16.67ms to 20 ms or 25 ms; however, the number of activity periods during one frame, i.e., the charging numbers of the liquid crystal capacitor C_{LC} during one frame, is not altered. For example, for frame rate 60 Hz, 50 Hz, and 40Hz, a same control signal includes a same predetermined number of activity periods during one frame. In addition, because the predetermined activity periods are evenly distributed in one frame according the embodiment of figure 10, the period of each activity period is adaptively increased for example the activity period at the frame rate 50 Hz or 40Hz is longer than that at frame rate 60Hz. The period of each activity period being increased means that the charging time is adaptively increased, i.e., the charging frequency is decreased during a same period of time, so that the objective of low power consumption can be achieved. In other words, the principle of embodiment of figure 10 is that

when the period of one frame is increased in responsive to the frame rate being decreased, the period of one activity period of each control signal is increased, i.e., the charging time of the liquid crystal capacitor is increased, but the number of the activity periods during one frame is not altered, so that the objective of low power consumption can be achieved.

[0023] Referring to figure 11, which shows the adaptive adjustment of the control signals according to another embodiment of the present invention. In this embodiment, when the period of one frame is increased in responsive to the frame rate being decreased, the period of one activity period of each control signal is not altered, the number of the activity periods of one frame is also not altered, and after all the activity periods are completed, the control signal are kept inactive until the end of current frame. For example, when the frame rate is decreased to 50 Hz or 40 Hz, the period of one frame is increased to 20 ms or 25 ms. In addition, the period of the activity period (1H) of the frame rate 50 Hz and 40 Hz are same as which of the frame rate 60 Hz for the same control signal (such as DE), the number of the activity periods of one frame is not altered, and after all the activity periods are completed, the control signal are kept inactive, i.e., "signal low," until the end of current frame. Accordingly, the average power consumption of lower frame rate (such as 40 Hz or 50 Hz) is lower than that of the unchanged frame rate (such as 60Hz); therefore, the objective of low power consumption can be achieved.

[0024] According to the driving method and Liquid Crystal Display of the present invention, the frame rate of the Liquid Crystal Display can be dynamically changed under the normal operation. In addition, incorporating other power-conserving methods as well known may further decrease the power consumption.

[0025] Although specific embodiments have been illustrated and described, it will be appreciated by those skilled in the art that various modifications may be made without departing from the scope of the present invention, which is intended to be limited solely by the appended claims.

Claims

1. A driving method of a Liquid Crystal Display, the Liquid Crystal Display comprising a processor and a display panel, said processor controlling said display panel, the method comprising the steps of:

executing a normal operation, said processor outputting a plurality of control signals to a data driver, said data driver outputting a plurality of data voltages to said display panel via a plurality of data lines, said Liquid Crystal Display being displayed at a constant initial frame rate; and executing a idle detecting step to check whether an idle event is met or executing a first manip-

ulation detecting step to check whether a manipulation event is met, when a percentage or more of the plurality of data voltages are unchanged after a period of time, or when a manipulation event is met and the manipulation event selects a specific display mode, the initial frame rate is decreased to a first frame rate.

2. The driving method as recited in claim 1, wherein the percentage of the plurality of data voltages is defined as 50% or more of the plurality of data voltages.
3. The driving method as recited in claim 1, after the initial frame rate is decreased to the first frame rate, the idle detecting step is performed again to check whether the idle event is met; when the percentage or more of the plurality of data voltages are unchanged after the period of time, the first frame rate is decreased to a second frame rate; when the percentage or more of the plurality of data voltages are changed after the period of time, the first frame rate is increased to the initial frame rate.
4. The driving method as recited in claim 3, wherein the second frame rate is smaller than, larger than, or equal to the first frame rate, and both the first and second frame rate are smaller than the initial frame rate.
5. The driving method as recited in claim 4, wherein the first frame rate and the second frame rate have a lower limit value that is the minimized value under the condition that the Liquid Crystal Display has no flicker.
6. The driving method as recited in claim 1, after the frame rate is decreased to the first frame rate, a second manipulation detecting step is performed to check whether a manipulation event is met; when the manipulation event is met, the first frame rate is recovered to the initial frame rate or decreased to a second frame rate according to the manipulation event, wherein the second frame rate is larger than, smaller than, or equal to the first frame rate.
7. The driving method as recited in claim 1, wherein said processor further outputs a plurality of control signals to a gate driver; when the percentage or more of the plurality of data voltages are unchanged after the period of time, the period of each frame is increased, the number of activity periods of each control signal is unchanged, and the activity periods of each control signal is evenly distributed in each frame so that the period of activity period of each control signal is increased.
8. The driving method as recited in claim 1, wherein

said processor further outputs a plurality of control signals to a gate driver; when the percentage or more of the plurality of data voltages are unchanged after the period of time, the period of each frame is increased, the number of activity periods of each control signal during one frame is unchanged, the period of activity period of each control signal is unchanged, and after all the activity periods during one frame are completed, the control signal are kept inactive until the end of the frame for each control signal.

9. A Liquid Crystal Display, comprising:

a display panel;
a timing controller, for outputting a plurality of control signals; and
a data driver, for receiving said plurality of control signals and outputting a plurality of data voltages to said display panel via a plurality of data lines, said Liquid Crystal Display being displayed at a constant initial frame rate under a normal operation;
wherein the timing controller executes a idle detecting step to check whether an idle event is met or executes a first manipulation detecting step to check whether a manipulation event is met, when a percentage or more of the plurality of data voltages are unchanged after a period of time, or when a manipulation event is met and the manipulation event selects a specific display mode, the initial frame rate is decreased to a first frame.

10. The Liquid Crystal Display as recited in claim 9, wherein the percentage of the plurality of data voltages is defined as 50% or more of the plurality of data voltages.

40

45

50

55

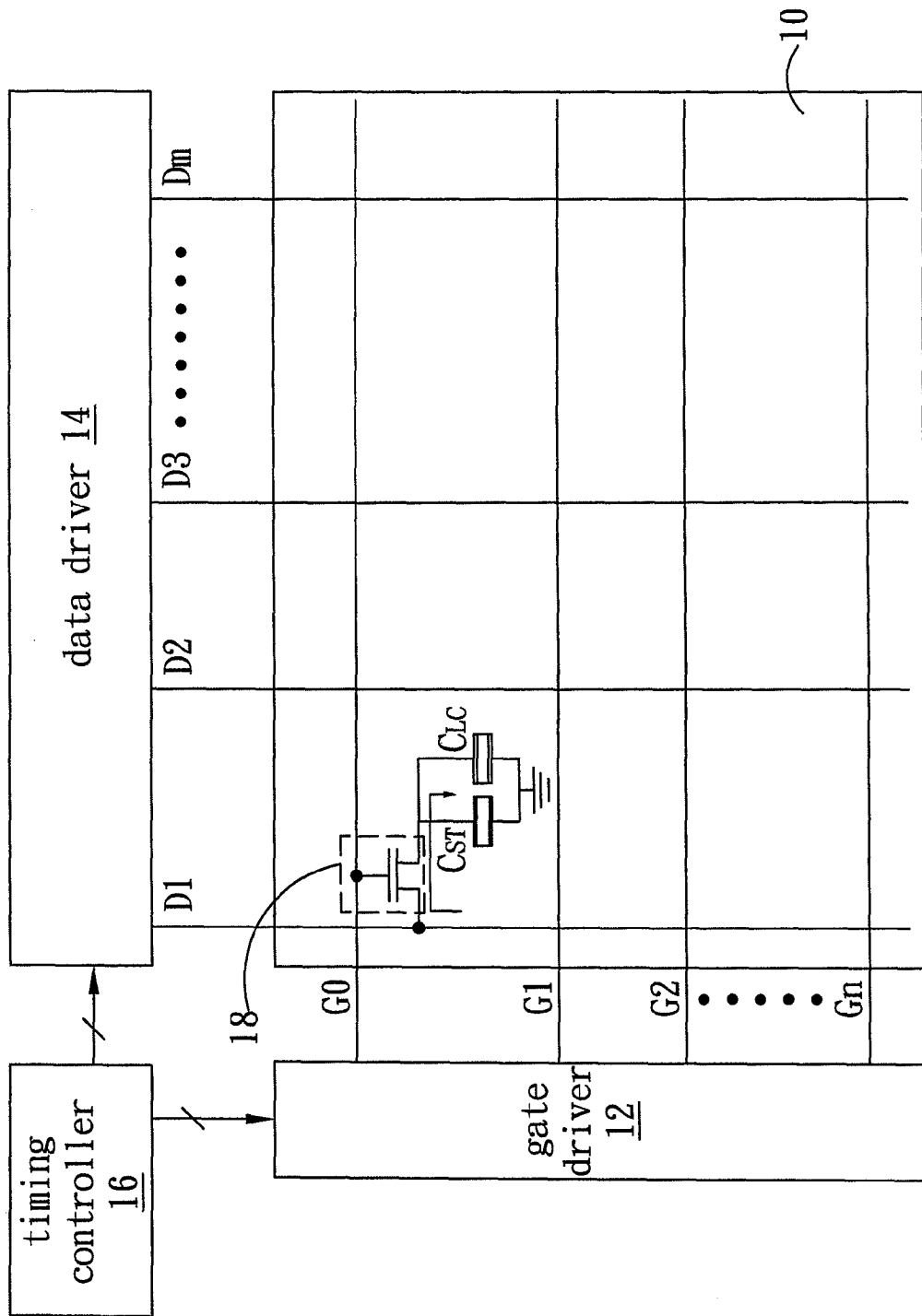

FIG. 1 (Prior Art)

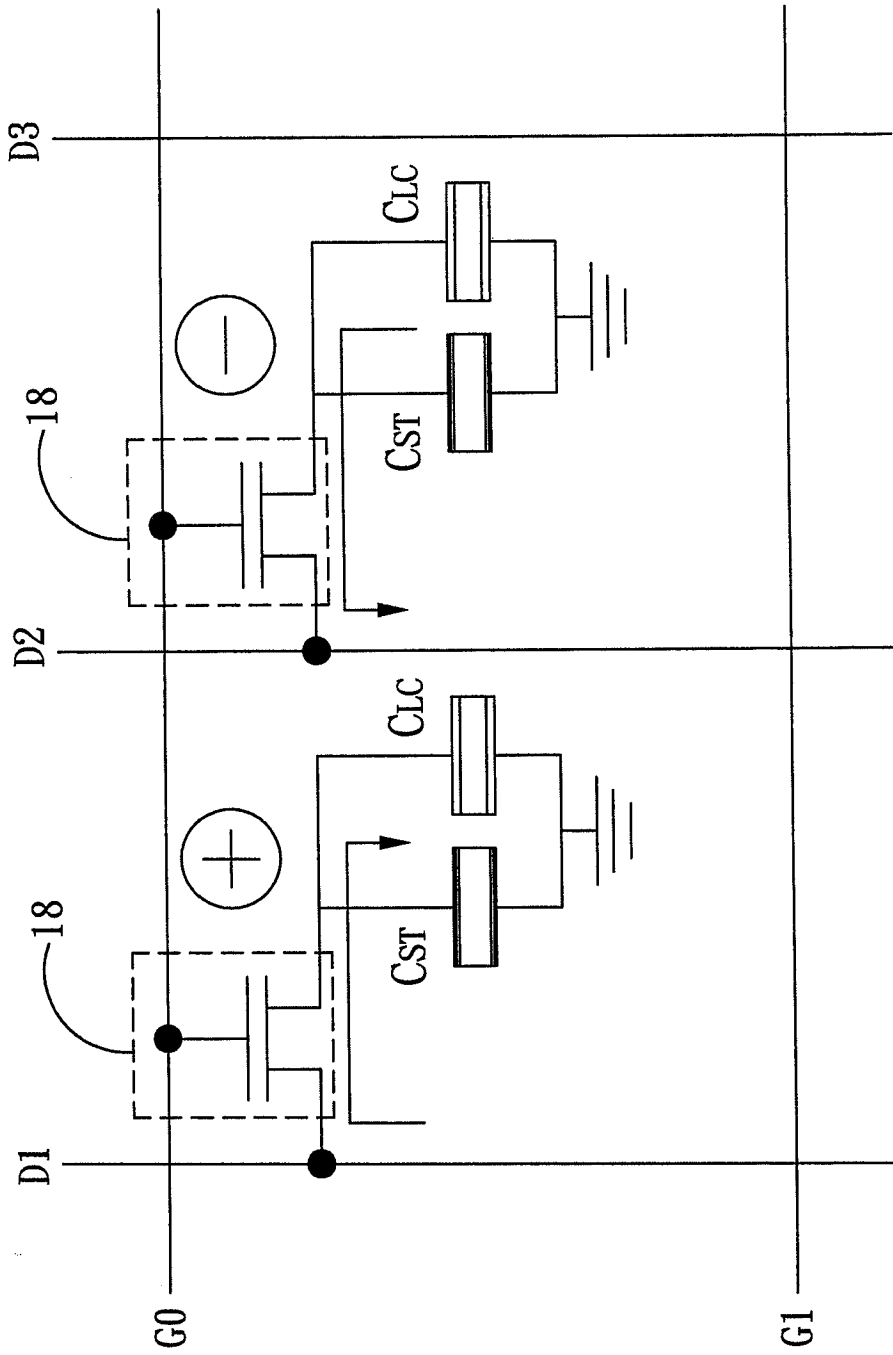

FIG. 2 (Prior Art)

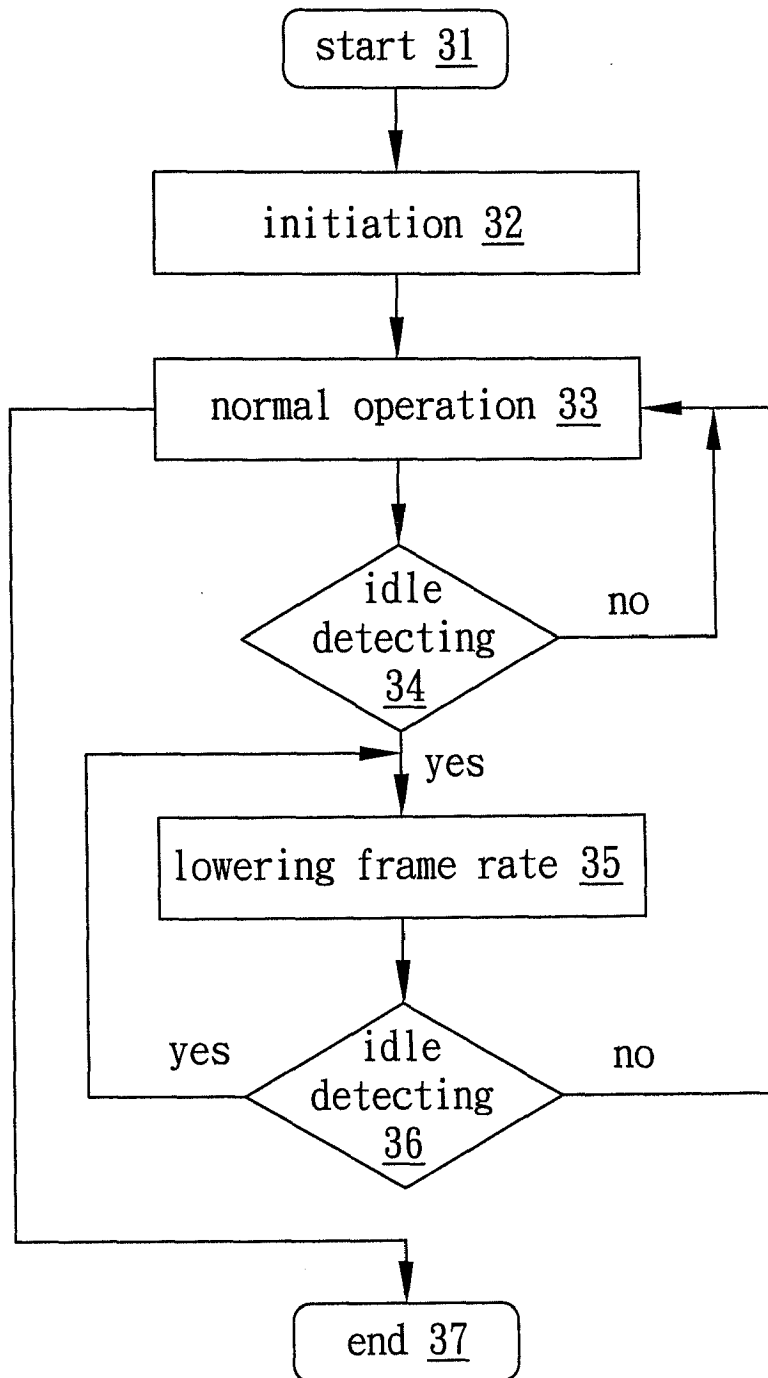

FIG. 3

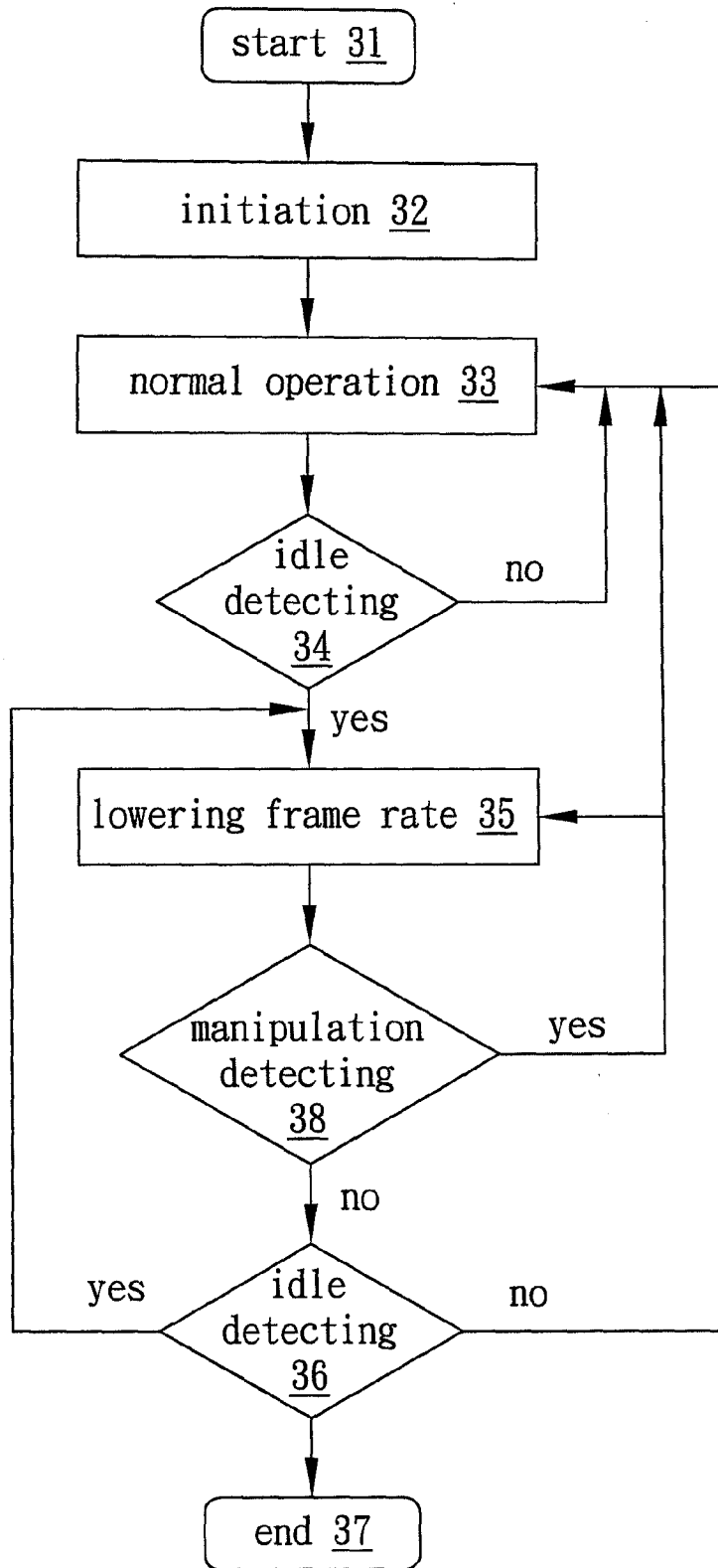

FIG. 4

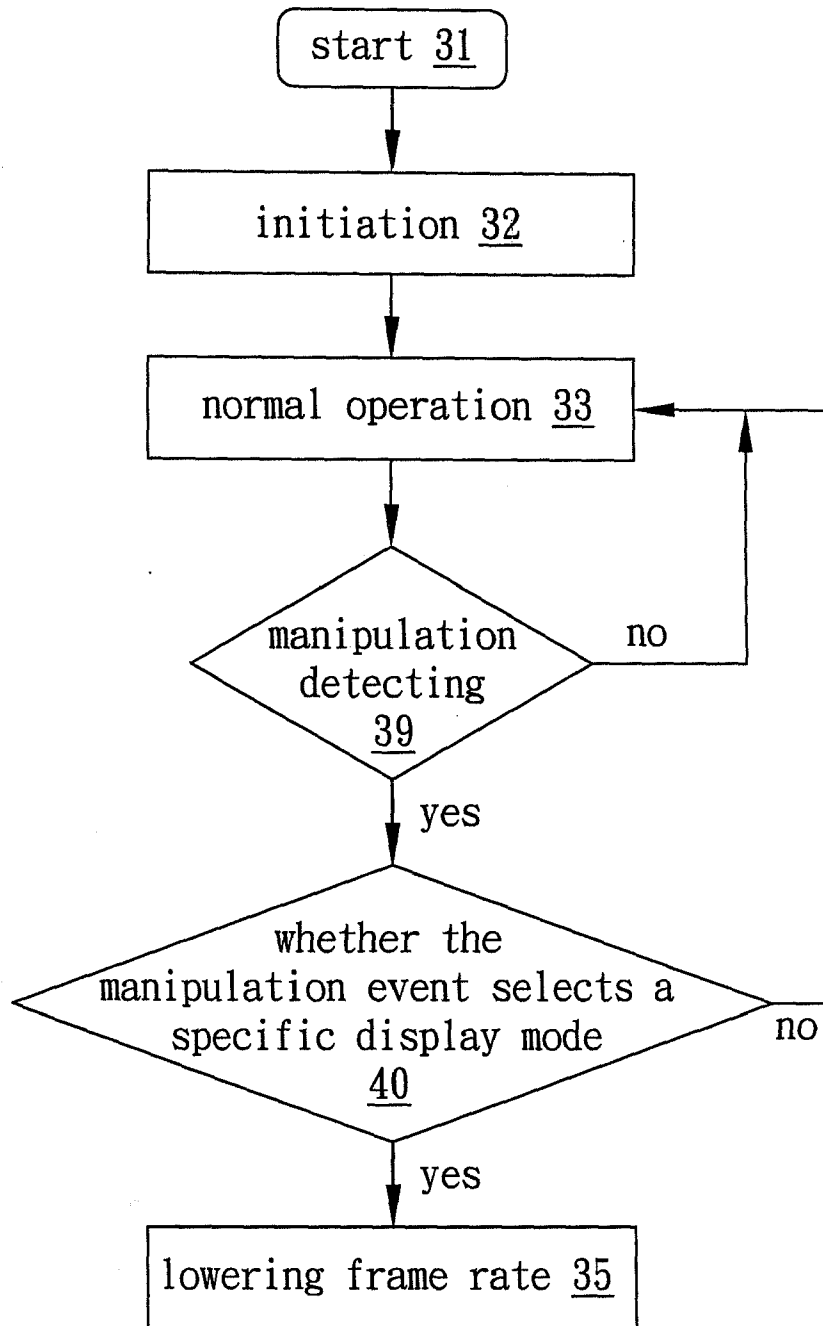

FIG. 5

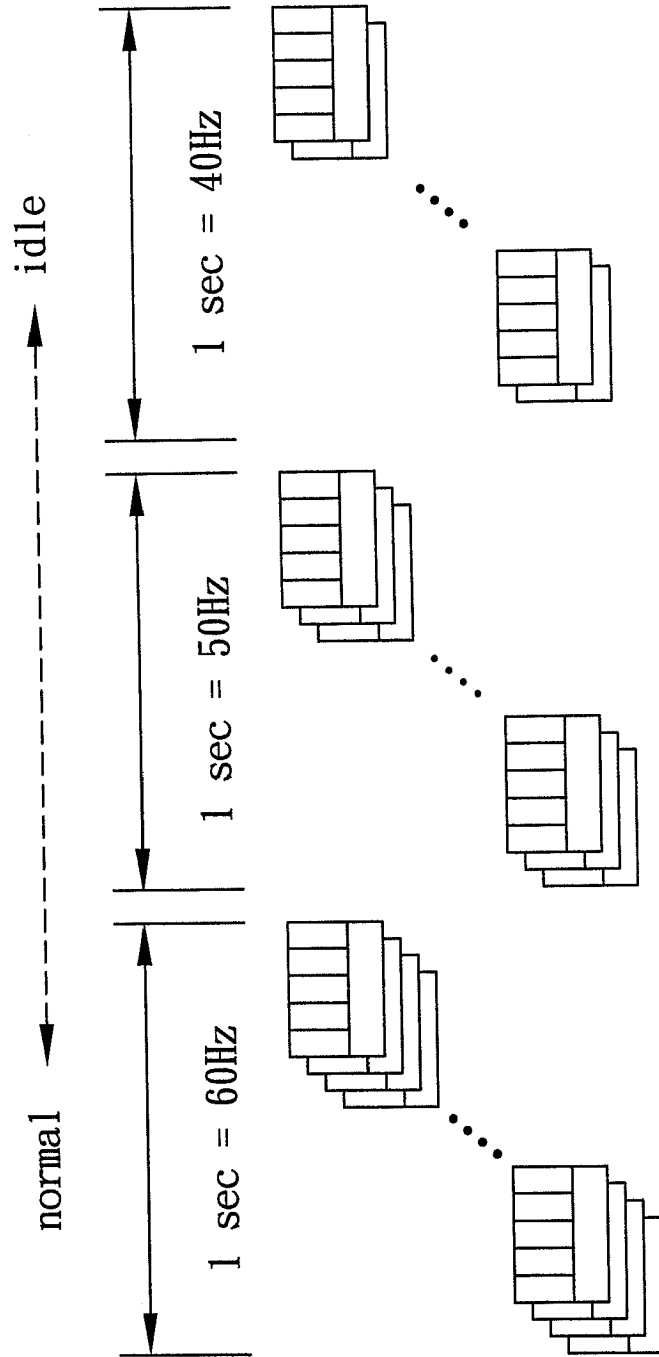

FIG. 6

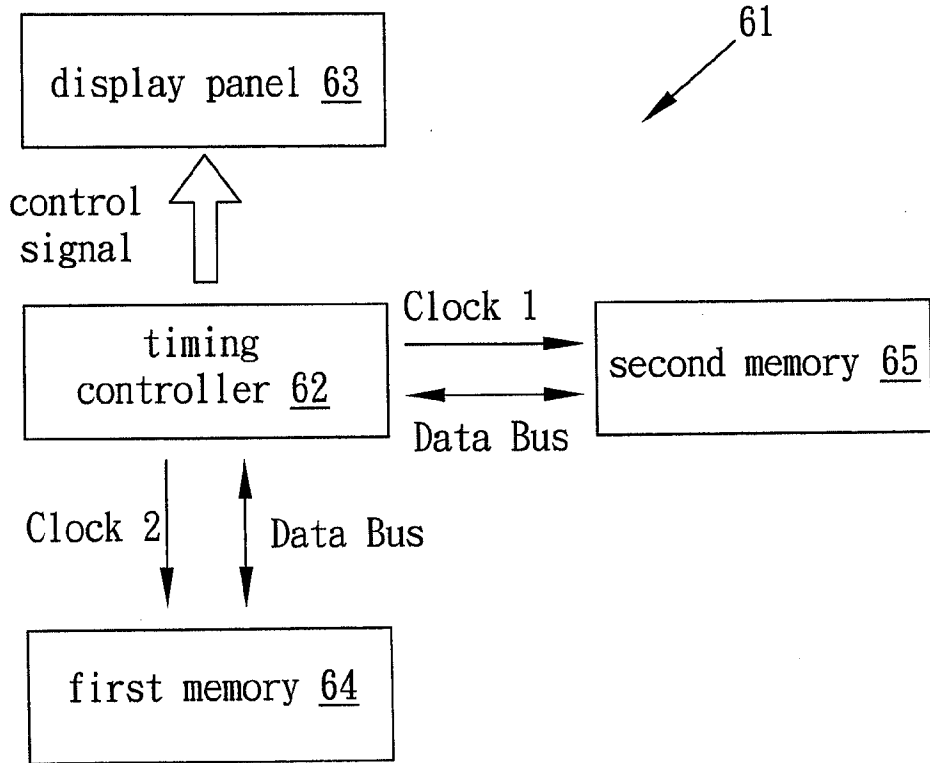

FIG. 7

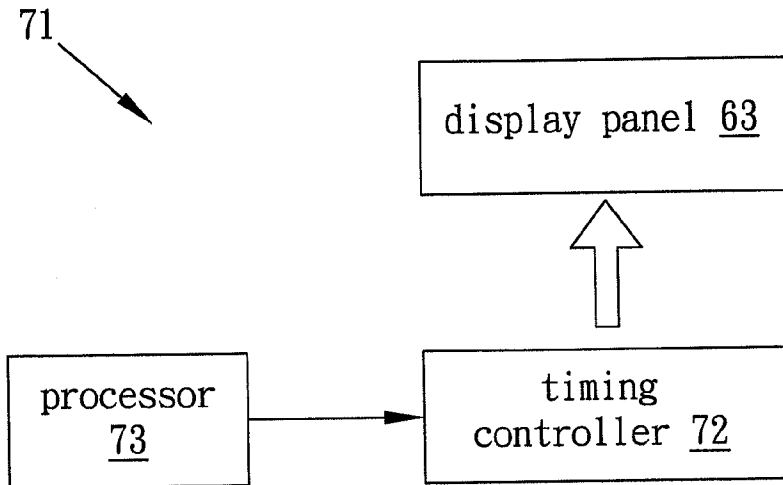

FIG. 8

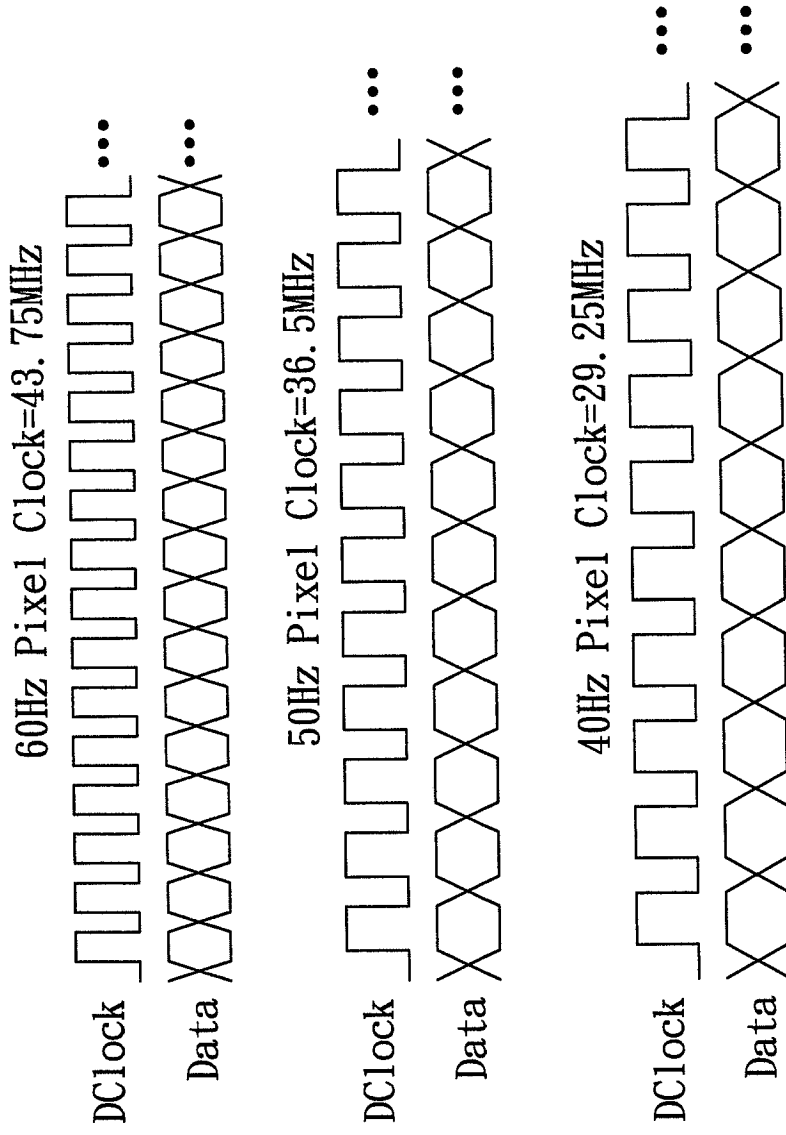

FIG. 9

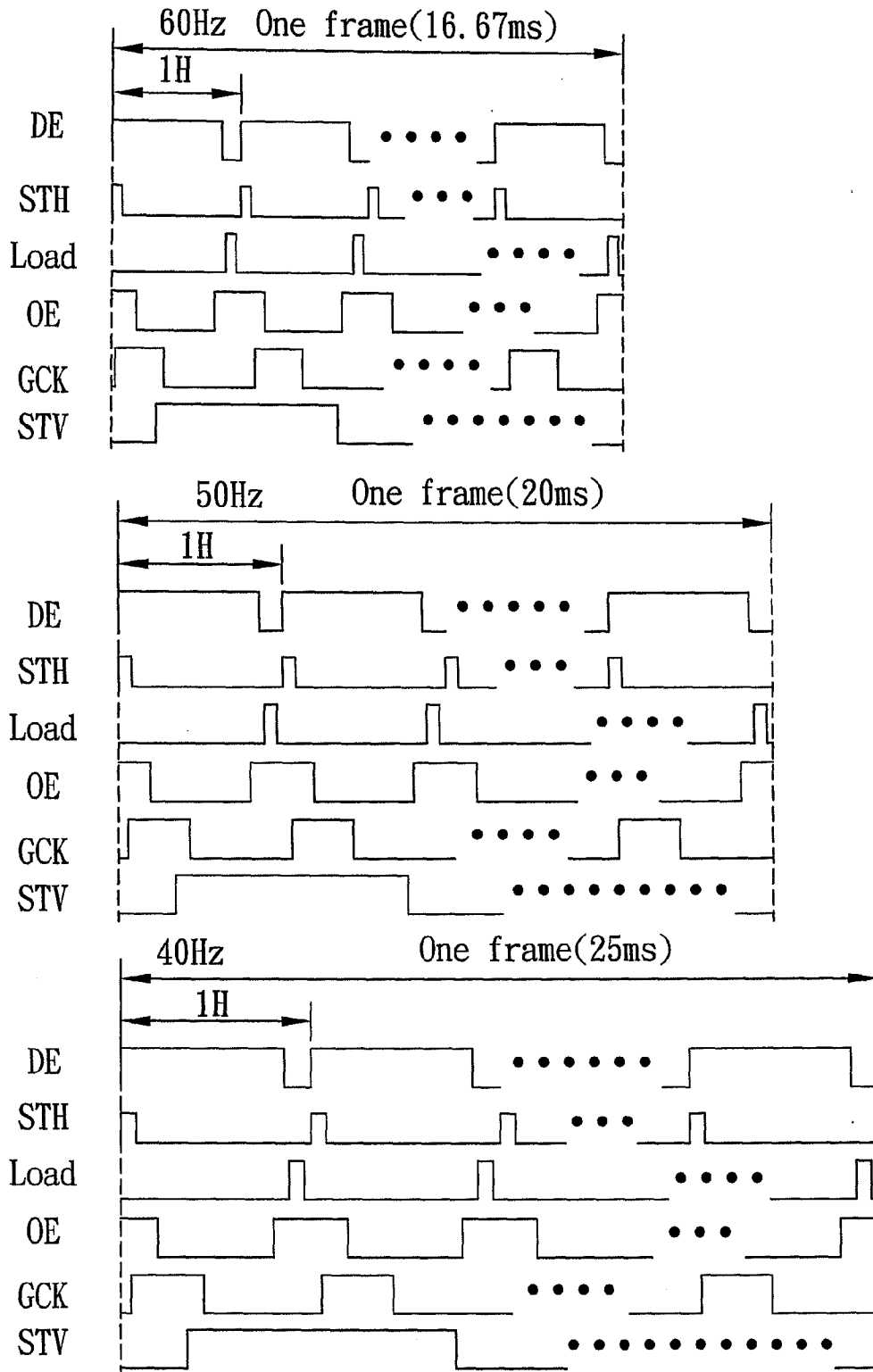

FIG. 10

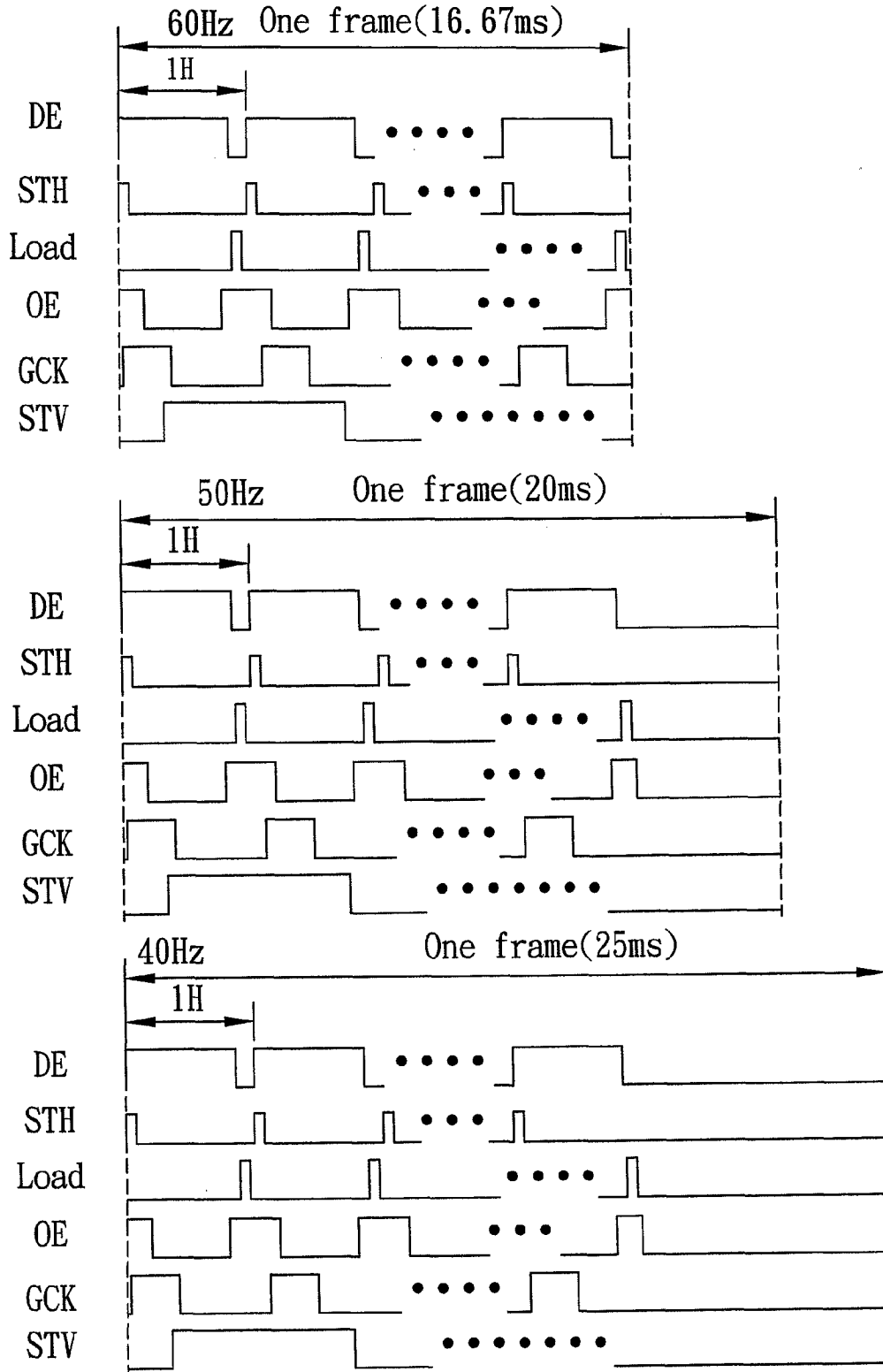

FIG. 11



EUROPEAN SEARCH REPORT

Application Number
EP 09 16 6227

| DOCUMENTS CONSIDERED TO BE RELEVANT | | | | |
|--|--|---|---|--|
| Category | Citation of document with indication, where appropriate, of relevant passages | Relevant to claim | CLASSIFICATION OF THE APPLICATION (IPC) | |
| X | JP 2002 175049 A (SONY CORP) 21 June 2002 (2002-06-21) | 1-5,7-10 | INV. G09G3/36 | |
| Y | * paragraph [0003] - paragraph [0007] * * paragraph [0015] - paragraph [0027]; figure 3 * * paragraph [0046] - paragraph [0054]; figures 6, 7 * | 1,6,9 | | |
| X | US 2004/043800 A1 (HOSOI TOSHIKATSU [JP]) 4 March 2004 (2004-03-04) | 1,3-5, 7-9 | | |
| Y | * paragraph [0093] - paragraph [0119]; figures 3-7 * | 1,6,9 | | |
| X | US 2004/080500 A1 (KOYAMA JUN [JP]) 29 April 2004 (2004-04-29) | 1,3-5, 7-9 | | |
| Y | * paragraph [0041] - paragraph [0047]; figures 1,7 * | 2,10 | | |
| X | EP 1 180 762 A2 (SHARP KK [JP]) 20 February 2002 (2002-02-20) | 1,3-5, 7-9 | | TECHNICAL FIELDS SEARCHED (IPC) G09G |
| Y | * paragraph [0025] - paragraph [0031]; figure 4 * * paragraph [0045] - paragraph [0070]; figures 2-14 * * paragraph [0107] - paragraph [0113] * | 2,10 | | |
| Y | WO 2007/105548 A1 (CANON KK [JP]; INOUE KENJI [JP]) 20 September 2007 (2007-09-20) * page 3, line 16 - line 26 * * page 9, line 9 - page 19, line 13; figures 3-10 * | 1,6,9 | | |
| The present search report has been drawn up for all claims | | | | |
| Place of search Munich | | Date of completion of the search 8 June 2010 | Examiner Morris, David | |
| CATEGORY OF CITED DOCUMENTS X : particularly relevant if taken alone Y : particularly relevant if combined with another document of the same category A : technological background O : non-written disclosure P : intermediate document | | T : theory or principle underlying the invention E : earlier patent document, but published on, or after the filing date D : document cited in the application L : document cited for other reasons & : member of the same patent family, corresponding document | | |

3
EPO FORM 1503_03.02 (P04C01)



Application Number

EP 09 16 6227

CLAIMS INCURRING FEES

The present European patent application comprised at the time of filing claims for which payment was due.

- Only part of the claims have been paid within the prescribed time limit. The present European search report has been drawn up for those claims for which no payment was due and for those claims for which claims fees have been paid, namely claim(s):
- No claims fees have been paid within the prescribed time limit. The present European search report has been drawn up for those claims for which no payment was due.

LACK OF UNITY OF INVENTION

The Search Division considers that the present European patent application does not comply with the requirements of unity of invention and relates to several inventions or groups of inventions, namely:

see sheet B

- All further search fees have been paid within the fixed time limit. The present European search report has been drawn up for all claims.
- As all searchable claims could be searched without effort justifying an additional fee, the Search Division did not invite payment of any additional fee.
- Only part of the further search fees have been paid within the fixed time limit. The present European search report has been drawn up for those parts of the European patent application which relate to the inventions in respect of which search fees have been paid, namely claims:
- None of the further search fees have been paid within the fixed time limit. The present European search report has been drawn up for those parts of the European patent application which relate to the invention first mentioned in the claims, namely claims:
- The present supplementary European search report has been drawn up for those parts of the European patent application which relate to the invention first mentioned in the claims (Rule 164 (1) EPC).



**LACK OF UNITY OF INVENTION
SHEET B**

Application Number

EP 09 16 6227

The Search Division considers that the present European patent application does not comply with the requirements of unity of invention and relates to several inventions or groups of inventions, namely:

1. claims: 1-5, 7-10(all partially)

- executing a idle detecting step to check whether an idle event is met; and
 - [determining] when a percentage or more of the plurality of data voltages are unchanged after a period of time.
-

2. claims: 6(completely); 1, 9(partially)

- executing a first manipulation detecting step to check whether a manipulation event is met; and
 - [dermining] when a manipulation event is met and [whether] the manipulation event selects a specific display mode
-

ANNEX TO THE EUROPEAN SEARCH REPORT
ON EUROPEAN PATENT APPLICATION NO.

EP 09 16 6227

This annex lists the patent family members relating to the patent documents cited in the above-mentioned European search report.
The members are as contained in the European Patent Office EDP file on
The European Patent Office is in no way liable for these particulars which are merely given for the purpose of information.

08-06-2010

| Patent document cited in search report | | Publication date | Patent family member(s) | Publication date |
|---|----|---------------------|----------------------------|---------------------|
| JP 2002175049 | A | 21-06-2002 | CN 1783196 A | 07-06-2006 |
| | | | CN 1909050 A | 07-02-2007 |
| | | | CN 1917024 A | 21-02-2007 |
| ----- | | | | |
| US 2004043800 | A1 | 04-03-2004 | CN 1487768 A | 07-04-2004 |
| | | | GB 2394332 A | 21-04-2004 |
| | | | JP 2004096534 A | 25-03-2004 |
| ----- | | | | |
| US 2004080500 | A1 | 29-04-2004 | CN 1497517 A | 19-05-2004 |
| | | | JP 2004146082 A | 20-05-2004 |
| ----- | | | | |
| EP 1180762 | A2 | 20-02-2002 | CN 1339934 A | 13-03-2002 |
| | | | DE 60111314 D1 | 14-07-2005 |
| | | | DE 60111314 T2 | 14-06-2006 |
| | | | JP 4212791 B2 | 21-01-2009 |
| | | | JP 2002123234 A | 26-04-2002 |
| | | | KR 20020013748 A | 21-02-2002 |
| | | | TW 533664 B | 21-05-2003 |
| | | | US 2002036636 A1 | 28-03-2002 |
| ----- | | | | |
| WO 2007105548 | A1 | 20-09-2007 | CN 101395656 A | 25-03-2009 |
| | | | EP 1991981 A1 | 19-11-2008 |
| | | | JP 2007240741 A | 20-09-2007 |
| | | | US 2009033969 A1 | 05-02-2009 |
| ----- | | | | |

| | | | |
|----------------|---|---------|------------|
| 专利名称(译) | 液晶显示器及其省电方法 | | |
| 公开(公告)号 | EP2234099A1 | 公开(公告)日 | 2010-09-29 |
| 申请号 | EP2009166227 | 申请日 | 2009-07-23 |
| [标]申请(专利权)人(译) | 瀚宇彩晶股份有限公司 | | |
| 申请(专利权)人(译) | 瀚宇彩晶股份有限公司. | | |
| 当前申请(专利权)人(译) | 瀚宇彩晶股份有限公司. | | |
| [标]发明人 | CHENG CHIEN YUNG | | |
| 发明人 | CHENG, CHIEN-YUNG | | |
| IPC分类号 | G09G3/36 | | |
| CPC分类号 | G09G3/3648 G09G3/2096 G09G3/3666 G09G3/3677 G09G5/12 G09G2300/0486 G09G2330/022 G09G2330/023 G09G2360/12 G09G2360/128 | | |
| 代理机构(译) | 庆祝活动, JENTSCHURA & PARTNER | | |
| 优先权 | 098110246 2009-03-27 TW | | |
| 其他公开文献 | EP2234099B1 | | |
| 外部链接 | Espacenet | | |

摘要(译)

本发明的实施例公开了具有低功耗的液晶显示器。在正常操作下，多个数据电压被输入到具有恒定帧速率的显示面板，并且执行空闲检测步骤以确定帧数据电压是否发生变化。当在特定时间段之后多个数据电压的百分比不变时，帧速率降低。

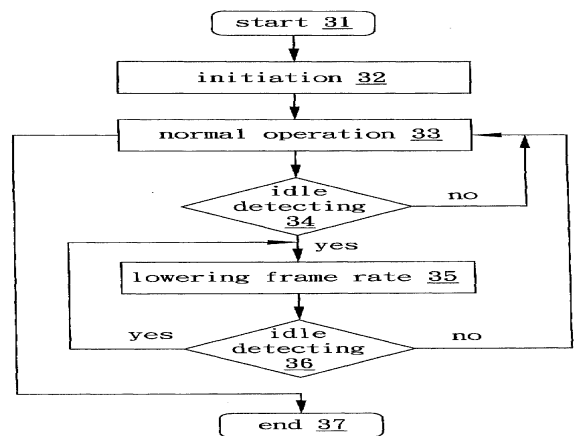

FIG. 3