

(19)



(11)

EP 2 224 283 A1

(12)

EUROPEAN PATENT APPLICATION
published in accordance with Art. 153(4) EPC

(43) Date of publication:

01.09.2010 Bulletin 2010/35

(51) Int Cl.:

G02F 1/1337 (2006.01) G02F 1/1343 (2006.01)

(21) Application number: **08867596.2**

(86) International application number:

PCT/JP2008/003722

(22) Date of filing: **11.12.2008**

(87) International publication number:

WO 2009/084162 (09.07.2009 Gazette 2009/28)

(84) Designated Contracting States:

AT BE BG CH CY CZ DE DK EE ES FI FR GB GR HR HU IE IS IT LI LT LU LV MC MT NL NO PL PT RO SE SI SK TR

Designated Extension States:

AL BA MK RS

• **SHIBASAKI, Masakazu**

**Osaka-shi
Osaka 545-8522 (JP)**

• **IYAMA, Yuichi**

**Osaka-shi
Osaka 545-8522 (JP)**

• **KUBO, Masumi**

**Osaka-shi
Osaka 545-8522 (JP)**

• **SOGA, Masayuki**

**Osaka-shi
Osaka 545-8522 (JP)**

(30) Priority: **28.12.2007 JP 2007340854**

(71) Applicant: **Sharp Kabushiki Kaisha**

Osaka-shi, Osaka 545-8522 (JP)

(74) Representative: **Zinke, Thomas**

**Müller Hoffmann & Partner
Patentanwälte
Innere Wiener Straße 17
81667 München (DE)**

(72) Inventors:

• **OHGAMI, Hiroyuki**

**Osaka-shi
Osaka 545-8522 (JP)**

• **HASHIMOTO, Yoshito**

**Osaka-shi
Osaka 545-8522 (JP)**

(54) LIQUID CRYSTAL DISPLAY DEVICE

(57) There is provided a liquid crystal display device of high picture quality with high brightness and small display unevenness.

A vertical alignment type liquid crystal display device which has a plurality of pixels includes: a first electrode which includes, in each of the plurality of pixels, a plurality of first branch portions extending in a first direction and a plurality of second branch portions extending in a second direction that is different from the first direction; a second electrode disposed so as to oppose the first electrode; and a liquid crystal layer interposed between the first electrode and the second electrode, wherein a width of each of the plurality of first branch portions and the plurality of second branch portions is in a range not less than 1.4 μm and not more than 8.0 μm .

FIG. 1

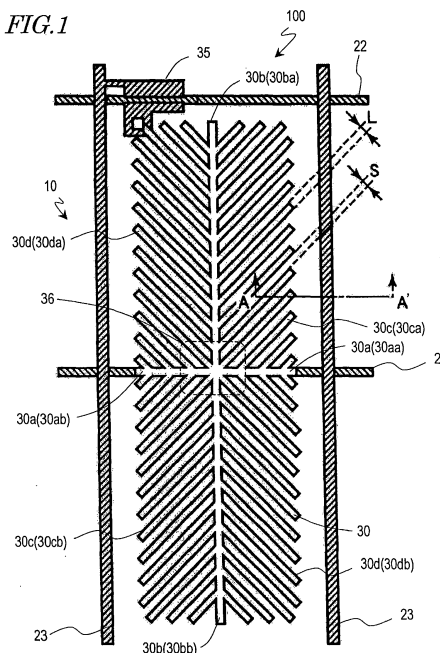

EP 2 224 283 A1

Description**TECHNICAL FIELD**

5 [0001] The present invention relates to a liquid crystal display device and specifically to a vertical alignment type liquid crystal display device which has a plurality of divisional alignment regions in a pixel.

BACKGROUND ART

10 [0002] As of now, liquid crystal display devices under development which have wide viewing angle characteristics includes liquid crystal display devices utilizing the IPS (In-Plane-Switching) mode which is a transverse electric field mode or the FFS (Fringe Field Switching) mode, and liquid crystal display devices utilizing the VA (Vertical Alignment) mode. The VA mode is better for mass production than the transverse electric field mode and is therefore used in a wide range of TV applications and mobile applications.

15 [0003] The VA mode liquid crystal display devices are generally classified into MVA (Multidomain Vertical Alignment) mode liquid crystal display devices, in which one pixel includes a plurality of domains of different liquid crystal alignment directions, and CPA (Continuous Pinwheel Alignment) mode liquid crystal display devices in which the liquid crystal alignment direction continuously varies around a rivet or the like formed on an electrode at the center of a pixel.

20 [0004] In the MVA mode liquid crystal display devices, the alignment control means which extend in two mutually-orthogonal directions are provided to form four liquid crystal domains in one pixel, in which the azimuthal angles of the directors representing the liquid crystal domains are 45° relative to the polarization axes (transmission axes) of a pair of polarizing plates in a crossed nicols arrangement. Assuming that the direction of the polarization axis of one of the polarizing plates is azimuthal angle 0° and that the counterclockwise direction is the positive direction, the azimuthal angles of the directors of the four liquid crystal domains are 45°, 135°, 225°, and 315°. Selection of these azimuthal angles of the directors is most preferable in respect of transmittance because linearly-polarized light in the direction of 45° relative to the polarization axis is not absorbed by the polarizing plates. Such a structure which includes four domains in one pixel is referred to as "four-division alignment structure" or simply "4D structure".

25 [0005] When slits (or ribs) are used as the alignment control means in the MVA mode liquid crystal display devices, the width of the slits need to be about 10 μm or more in order to obtain a sufficient alignment control force. If the slit width is narrower than this, sufficient alignment control force cannot be obtained. To form four domains, it is necessary to form in a counter electrode slits extending in directions different by 90° when seen in a direction normal to the substrate ("<"-shaped slit) and to form in a pixel electrode slits which are separated by a certain space from the counter electrode slits and which extend parallel to the counter electrode slits. Specifically, both the counter electrode and the pixel electrode in one pixel need to have a plurality of slits extending in the direction of 45°-225° and the direction of 135°-315° and having the width of about 10 μm.

30 [0006] However, when the above-described slits are employed, the ratio of the area of the slits to the pixel area increases, and accordingly, part of the pixel area which fails to contribute to display increases, so that the transmittance (brightness) significantly decreases. In the case of a small-size liquid crystal display device of finer definition, e.g., 2.4-inch VGA for use in mobile phones, the pixel pitch (row direction×vertical direction) is, for example, 25.5 μm×76.5 μm. In such a small pixel, the above-described slits cannot be formed.

35 [0007] In the CPA mode liquid crystal display devices, a rivet is formed of a resin or the like in the counter electrode at the pixel center, such that the rivet and a diagonal electric field produced at an edge of the pixel electrode serve to regulate the alignment of the liquid crystal. Provided in the respective gaps between the two polarizing plates and the liquid crystal layer are 1/4-wave plates (quarter wave plates). By utilizing omniazimuthal, radial slope alignment domains and circular polarization, high transmittance (brightness) can be achieved.

40 [0008] The CPA mode which utilizes the 1/4-wave plates achieves high transmittance but disadvantageously provides a low contrast ratio and a narrow viewing angle as compared with the MVA mode. Specifically, when the 1/4-wave plates are used, the display (especially, the display at lower gray levels (lower brightness)) appears brighter, i.e., so-called "whitish dots" are conspicuous, when observed in a diagonal viewing angle than when observed in front of the display surface (when observed in a direction normal to the display surface (viewing angle 0°)).

45 [0009] To solve the above problems of the liquid crystal display device in the MVA mode and the CPA mode, liquid crystal display devices as disclosed in Patent Document 1, Patent Document 2, and Patent Document 3 have been proposed. In the liquid crystal display devices of these patent documents, the four-division alignment structure is realized by forming in the pixel electrodes a large number of narrow slits extending in the direction of 45°-225° and in the direction of 135°-315° (referred to as "fishbone pixel electrode") such that the liquid crystal is aligned parallel to the slits. In liquid crystal display devices which use such fishbone pixel electrodes, large slits or rivets are not formed in pixels, and linearly-polarized light is used without using 1/4-wave plates. Therefore, display can be realized with high transmittance, high contrast ratio, and wide viewing angle.

[0010] Note that the liquid crystal display devices of these patent documents include alignment sustaining layers on surfaces of the upper and lower substrates on the liquid crystal layer side for making the liquid crystal have an appropriate pretilt angle during absence of voltage application to the liquid crystal. These alignment sustaining layers are formed by polymerizing monomers contained in the liquid crystal layer during application of a voltage to the liquid crystal.

[Patent Document 1] Japanese Laid-Open Patent Publication No. 2002-107730

[Patent Document 2] Japanese Laid-Open Patent Publication No. 2003-149647

[Patent Document 3] Japanese Laid-Open Patent Publication No. 2006-330638

DISCLOSURE OF INVENTION

PROBLEMS TO BE SOLVED BY THE INVENTION

[0011] The pixel electrodes of the liquid crystal display devices described in the aforementioned patent documents have a plurality of linear electrode portions (also referred to as "line portions") extending in the direction of 45°-225° and the direction of 135°-315°. Abnormal alignment of the liquid crystal, or such a phenomenon that the liquid crystal alignment direction becomes unstable, can occur depending on the shape or size of the linear electrode portions or the shape or size of the plurality of slits extending parallel to the linear electrode portions (also referred to as "linear space portions"), resulting in the problems of variation in transmittance across the display surface, display unevenness, and abnormal gray scale.

[0012] The inventor of the present application conducted researches and found that, to meet severe display characteristic requirements for liquid crystal display devices in the future, it is necessary to increase the transmittance in each pixel and suppress the variation in transmittance among pixels in a display screen to be about 10% or lower. However, the shape and size of the linear electrode portions and slits which are optimum for achieving such high transmittance characteristics has not been researched. Also, the fishbone-type electrodes have not been researched as to what setting of the relationship between the width of the linear electrode portions and the width of the slits can achieve the best transmittance characteristics.

[0013] The present invention was conceived with the view of solving the above problems. One of the objects of the present invention is to provide a liquid crystal display device including fishbone-type electrodes of high display quality which has high transmittance and which has a reduced transmittance variation smaller than about 10% across the display surface.

MEANS FOR SOLVING THE PROBLEMS

[0014] A liquid crystal display device of the present invention is a vertical alignment type liquid crystal display device which has a plurality of pixels, including: a first electrode which includes, in each of the plurality of pixels, a plurality of first branch portions extending in a first direction and a plurality of second branch portions extending in a second direction that is different from the first direction; a second electrode disposed so as to oppose the first electrode; and a liquid crystal layer interposed between the first electrode and the second electrode, wherein a width of each of the plurality of first branch portions and the plurality of second branch portions is in a range not less than 1.4 μm and not more than 8.0 μm.

[0015] In one embodiment, any adjacent two of the plurality of first branch portions and any adjacent two of the plurality of second branch portions are separated by a space wider than 1.4 μm and narrower than 3.2 μm.

[0016] In one embodiment, when any adjacent two of the plurality of first branch portions and any adjacent two of the plurality of second branch portions are separated by a space wider than 1.4 μm and narrower than 2.1 μm, the width of each of the plurality of first branch portions and the plurality of second branch portions is in a range not less than 1.4 μm and not more than 3.5 μm.

[0017] In one embodiment, the width of each of the plurality of first branch portions and the plurality of second branch portions is in a range not less than 1.4 μm and not more than 5.0 μm.

[0018] In one embodiment, when any adjacent two of the plurality of first branch portions and any adjacent two of the plurality of second branch portions are separated by a space wider than 1.4 μm and narrower than 2.1 μm, the width of each of the plurality of first branch portions and the plurality of second branch portions is in a range not less than 1.4 μm and not more than 3.2 μm.

[0019] In one embodiment, the width of each of the plurality of first branch portions and the plurality of second branch portions is in a range not less than 1.4 μm and not more than 5.0 μm while any adjacent two of the plurality of first branch portions and any adjacent two of the plurality of second branch portions are separated by a space wider than 1.8 μm and narrower than 3.2 μm, or the width of each of the plurality of first branch portions and the plurality of second branch portions is in a range not less than 1.4 μm and not more than 3.2 μm while any adjacent two of the plurality of first branch portions and any adjacent two of the plurality of second branch portions are separated by a space wider

than 1.4 μm and equal to or narrower than 1.8 μm .

[0020] In one embodiment, the width of each of the plurality of first branch portions and the plurality of second branch portions is in a range more than 2.1 μm and less than 2.8 μm while any adjacent two of the plurality of first branch portions and any adjacent two of the plurality of second branch portions are separated by a space wider than 2.1 μm and narrower than 2.8 μm .

[0021] In one embodiment, the first electrode includes a trunk portion, the plurality of first branch portions extend from the trunk portion in the first direction, and the plurality of second branch portions extend from the trunk portion in the second direction.

[0022] In one embodiment, the liquid crystal display device further includes a pair of polarizing plates which have transmission axes orthogonal to each other, wherein the first direction and the second direction are orthogonal to each other, and directions of the transmission axes of the pair of polarizing plates and the first direction are different by 45°, 135°, 225°, or 315°.

[0023] In one embodiment, each of the plurality of pixels includes a first region and a second region which are separated by a line parallel to or perpendicular to the directions of the transmission axes of the pair of polarizing plates, each of the first region and the second region includes the plurality of first branch portions and the plurality of second branch portions, each of the plurality of first branch portions in the first region has a first width, and each of the plurality of first branch portions in the second region has a second width that is different from the first width.

[0024] In one embodiment, each of the plurality of second branch portions in the first region has the first width, and each of the plurality of second branch portions in the second region has the second width.

[0025] In one embodiment, any adjacent two of the plurality of first branch portions in the first region are separated by a first space, and any adjacent two of the plurality of first branch portions in the second region are separated by a second space that is different from the first space.

[0026] In one embodiment, any adjacent two of the plurality of second branch portions in the first region are separated by the first space, and any adjacent two of the plurality of second branch portions in the second region are separated by the second space.

EFFECTS OF THE INVENTION

[0027] A liquid crystal display device of the present invention includes fishbone-type electrodes which have branch portions of the above-specified width or fishbone-type electrodes in which the space between adjacent branch portions has the above-specified value. Therefore, the abnormal alignment and alignment shift of the liquid crystal are suppressed so that the alignment direction of the liquid crystal in each pixel can be stabilized to be in a correct direction. Thus, high quality display with no roughness is possible in which the variation in transmittance across the display surface is smaller than about 10%.

[0028] In a liquid crystal display device of the present invention, one pixel includes two regions between which the widths of branch portions of the fishbone-type electrode or the spaces between adjacent branch portions are different. Therefore, the variation in brightness is suppressed, and high quality display with excellent gray scale and viewing angle characteristics is achieved.

BRIEF DESCRIPTION OF DRAWINGS

[0029]

[FIG. 1] Plan view schematically showing the structure of one pixel in a liquid crystal display device **100** of embodiment 1 of the present invention.

[FIG. 2] A schematic cross-sectional view of the liquid crystal display device **100** taken along line **A-A'** of FIG. 1.

[FIG. 3] Graphs representing the transmittance variation degree T with constant line width L and varying slit width S of a pixel electrode **30**.

[FIG. 4] Images showing the white display of a pixel **10**. **(a)** shows a preferable display state achieved when both line width L and slit width S are 2.5 μm . **(b)** and **(c)** show unpreferable display states.

[FIG. 5] Graphs representing transmittance T with constant slit width S and varying line width L of the pixel electrode **30**.

[FIG. 6] Images showing the white display of the pixel **10**. **(a)** shows a preferable display state achieved when both line width L and slit width S are 2.5 μm . **(b)** and **(c)** show unpreferable display states.

[FIG. 7] A table of the numerical representations of the transmittance variation degree T shown in FIG. 3 and FIG. 5, showing all the values for the transmittance variation degree T which result from the combinations of line width L and slit width S .

[FIG. 8] A table showing the display quality evaluations by observers with line width L varying in the range of 1.4

μm to $8.0 \mu\text{m}$ and slit width S varying in the range of $1.4 \mu\text{m}$ to $5.0 \mu\text{m}$.

[FIG. 9] Plan view schematically showing the structure of one pixel in a liquid crystal display device of embodiment 2 of the present invention.

5 **DESCRIPTION OF THE REFERENCE NUMERALS**

[0030]

10, 10'	pixel
10 20	TFT substrate
21	glass substrate
22	scanning line
23	signal line
24	auxiliary capacitance line
15 25	insulation layer
30	pixel electrode
30a, 30b, 30aa, 30ab, 30ba, 30bb	trunk portion
30c, 30d,	branch portion
32 30ca, 30cb, 30da, 30db	alignment film
20 35	TFT
36	auxiliary capacitance electrode
40	counter substrate
41	transparent substrate
42	CF layer
25 43	common electrode
44	alignment film
50	liquid crystal layer
60a, 60b	polarizing plate
90a, 90a', 90b, 90b'	trunk portion
30 90c, 90c', 90d, 90d'	branch portion
95	first region
95'	second region
97	boundary line

35 **BEST MODE FOR CARRYING OUT THE INVENTION**

[0031] Hereinafter, the structures of liquid crystal display devices of embodiments of the present invention are described with reference to the drawings, although the present invention is not limited to the embodiments described below.

40 (Embodiment 1)

[0032] FIG. 1 is a plan view schematically showing a structure of one pixel of a liquid crystal display device **100** of embodiment 1 of the present invention. FIG. 2 is a schematic cross-sectional view of the liquid crystal display device **100** taken along line **A-A'** of FIG. 1.

45 **[0033]** The liquid crystal display device **100** is a vertical alignment type liquid crystal display device which includes a plurality of pixels **10** having the structure shown in FIG. 1 and which performs display in a normally-black mode using the pixels **10** arranged in a matrix. The liquid crystal display device **100** further includes, as shown in FIG. 2, a TFT substrate **20** which is an active matrix substrate, a counter substrate **40** which is a color filter substrate, and a liquid crystal layer **50** disposed between these substrates. The liquid crystal layer **50** includes nematic liquid crystal which has negative dielectric constant anisotropy ($\Delta\epsilon < 0$).

50 **[0034]** The outer side of the TFT substrate **20** (opposite to the liquid crystal layer **50**) is provided with a polarizing plate **60a**. The outer side of the counter substrate **40** is provided with a polarizing plate **60b**. The polarizing plates **60a** and **60b** are in a crossed nicols arrangement such that the light transmission axis of one of the polarizing plates extends in the horizontal direction of FIG. 1, and the light transmission axis of the other extends in the vertical direction. In the description below, the azimuthal direction from left to right in FIG. 1 is referred to as "azimuthal direction 0° ", relative to which the azimuthal angles are allocated counterclockwise.

55 **[0035]** As shown in FIG. 1 and FIG. 2, the TFT substrate **20** includes a glass substrate (transparent substrate) **21**, scanning lines (gate bus lines) **22**, signal lines (data bus lines) **23** and auxiliary capacitance lines (Cs lines) **24** which

are provided on the glass substrate **21**, an insulation layer **25** which is provided over the lines, and pixel electrodes **30** and an alignment film **32** which are provided on the insulation layer **25**.

[0036] Each of the pixels **10** is surrounded by two adjacent scanning lines **22** and two adjacent signal lines **23**. Each pixel **10** includes a TFT **35** for switching a display voltage for the pixel electrode **30**. The gate electrode and the source electrode of the TFT **35** are electrically connected to the scanning line **22** and the signal line **23**, respectively, and the drain electrode is electrically connected to the pixel electrode **30**. Provided under the pixel electrode **30** at the center of the pixel **10** is an auxiliary capacitance electrode **36** which is electrically connected to the auxiliary capacitance line **24**.

[0037] The counter substrate **40** includes a transparent substrate **41**, a CF (color filter) layer **42** provided on the transparent substrate **41** (on a surface of the transparent substrate on the liquid crystal layer side), a common electrode **43** provided on the CF layer **42**, and an alignment film **44** provided on the common electrode **43**.

[0038] The alignment film **32** of the TFT substrate **20** and the alignment film **44** of the counter substrate **40** both include an alignment layer and an alignment sustaining layer. The alignment layer is a vertical alignment film formed over the substrate by application. The alignment sustaining layer is formed, after the formation of liquid crystal cells, by photopolymerization of photopolymerizable monomers mixed in a liquid crystal material in advance with application of a voltage to the liquid crystal layer **50**. During the polymerization of the monomers, a voltage is applied across the liquid crystal layer **50** by the pixel electrode **30** and the counter electrode **43**. A diagonal electric field which occurs depending on the shape of the pixel electrode **30** causes liquid crystal molecules to align, and with the liquid crystal molecules being in that state, the monomers are irradiated with light to be polymerized.

[0039] Using the thus-formed alignment sustaining layer enables liquid crystal molecules to sustain (memorize) their alignment (azimuthal directions of pretilt) even after removal of the voltage (even in a state of no voltage application). The technique of forming such an alignment film is referred to as PSA (Polymer Sustained Alignment) technique. The details of this technique are described in Patent Documents 2 and 3. These patent documents are incorporated by reference in this specification. The detailed description of the alignment sustaining layer is herein omitted.

[0040] As shown in FIG. 1, the pixel electrode **30** includes a trunk portion **30a** extending in the direction of azimuthal angle 0° - 180° , a trunk portion **30b** extending in the direction of azimuthal angle 90° - 270° , a plurality of branch portions **30c** (first branch portions) extending in the direction of azimuthal angle 45° - 225° (first direction), and a plurality of branch portions **30d** (second branch portions) extending in the direction of azimuthal angle 135° - 315° (second direction).

[0041] The trunk portion **30a** includes a trunk portion **30aa** extending from the intersection of the trunk portion **30a** and the trunk portion **30b** which is near the center of the pixel **10** in the direction of azimuthal angle 0° and a trunk portion **30ab** extending from the intersection in the direction of azimuthal angle 180° . The trunk portion **30b** includes a trunk portion **30ba** extending from the intersection in the direction of azimuthal angle 90° and a trunk portion **30bb** extending from the intersection in the direction of azimuthal angle 270° .

[0042] The branch portions **30c** include a plurality of branch portions **30ca** extending from the trunk portion **30aa** or **30ba** in the direction of azimuthal angle 45° and a plurality of branch portions **30cb** extending from the trunk portion **30ab** or **30bb** in the direction of azimuthal angle 225° . The branch portions **30d** include a plurality of branch portions **30da** extending from the trunk portion **30ab** or **30ba** in the direction of azimuthal angle 135° and a plurality of branch portions **30db** extending from the trunk portion **30aa** or **30bb** in the direction of azimuthal angle 315° .

[0043] The pixel electrode **30** which has the above-described shape and the alignment films **32** and **44** form a multi-domain of 4D structure in one pixel **10**. When no voltage is applied, the azimuthal directions of the pretilt of the liquid crystal molecules in the four domains are parallel to the branch portions **30ca**, **30da**, **30cb** and **30db**, respectively, depending on the directions memorized in the alignment films **32** and **44**. When a voltage is applied, the liquid crystal molecules of the four domains are oriented in polar angle directions which are parallel to the branch portions **30ca**, **30da**, **30cb** and **30db** (the directions of the directors of the domains) and which are more parallel to the substrate surface. In this case, the azimuthal directions of the orientation are coincident with the pretilt directions, and therefore, the orientation in correct azimuthal directions with an extremely-high response rate is realized.

[0044] Next, the relationship of width L of the branch portions **30c** and **30d** of the pixel electrode **30** and the space between adjacent two of the branch portions **30c** and **30d** is described. The branch portions **30c** and **30d** have equal widths. Space S between any adjacent two of the branch portions **30c** and space S between any adjacent two of the branch portions **30d** are equal.

[0045] As shown in FIG. 1, width L of the branch portions **30c** and **30d** refers to the dimension perpendicular to the direction of elongation of the branch portions. Space S between any adjacent two of the branch portions **30c** and **30d** refers to the dimension of a gap (slit portion) formed between adjacent two branch portions which is perpendicular to the direction of elongation of the branch portions. Width L is sometimes referred to as "line width L". Space S is sometimes referred to as "slit width S".

[0046] The inventor of the present application estimated that, to meet severe display characteristic requirements for liquid crystal display devices in the future, it is necessary to prevent the variation in transmittance among pixels, which would be a cause of roughness in display, as well as the necessity of increasing the transmittance of the pixels. To this end, the inventor examined the optimum relationship between line width L and slit width S which is to be applied to the

pixels **10**. Hereinafter, the details of the examinations and the results obtained from the examinations are described. In liquid crystal display devices used in the examinations, the thickness of the liquid crystal layer **50** was 3.15 μm , and the pretilt angle of the liquid crystal molecules was 1.5° to 2.0°. The examinations were carried out with the gate voltage at 15 V and the source voltage at 4.4 V.

(Examination 1)

[0047] First, the relation of the transmittance of the pixels **10** to line width L and slit width S was examined. Note that, in this examination, the variation in transmittance among pixels was smallest when line width L was 2.5 μm and slit width S was 2.5 μm . Factor T employed in the examinations below represents the degree of the variation in transmittance of respective samples in percentages relative to the smallest transmittance variation (100%). The variation in transmittance is represented by the difference between the maximum transmittance and the minimum transmittance. Therefore, a larger T value indicates that the display is excellent with a smaller variation in transmittance.

[0048] FIG. **3** shows graphs representing the transmittance variation degree T (also simply referred to as "T") with constant line width L and varying slit width S. Graphs a, b, c, d, e, f, g, h, i, j, and k in FIG. **3** represent the relationship between slit width S and T, with line width L fixed at 1.4 μm , 1.8 μm , 2.1 μm , 2.5 μm , 2.8 μm , 3.2 μm , 3.5 μm , 4.2 μm , 5.0 μm , 6.0 μm , and 8.0 μm , respectively. Slit width S was changed in the range of 1.4 μm to 5.0 μm .

[0049] As seen from FIG. **3**, T of 90% or higher was achieved by selecting an appropriate value for slit width S no matter which value line width L was fixed (in any of cases a to k of FIG. **3**). Therefore, there is a probability that a desired, high reflectance characteristic can be achieved so long as line width L is in a range not less than 1.4 μm and not more than 8.0 μm . In other words, there is a probability that excellent display with small transmittance differences is realized so long as the width of each of the branch portions **30c** and **30d** of the pixel electrode **30** is in a range not less than 1.4 μm and not more than 8.0 μm .

[0050] FIG. **4** shows the white display of the pixel **10**. FIG. **4(a)** shows a preferable display state achieved when both line width L and slit width S were 2.5 μm . FIG. **4(b)** and FIG. **4(c)** show unpreferable display states which are described below.

[0051] When slit width S was not more than 1.4 μm , the alignment control force produced by the slit portion decreased so that the alignment of the liquid crystal near the slit portion became unstable. Therefore, the transmittance became nonuniform as shown in FIG. **4(b)** so that dark lines were generated. When slit width S was not less than 3.2 μm , the alignment control force could not be sufficiently exerted on all the liquid crystal molecules, so that abnormal alignment of the liquid crystal molecules occurred, and the transmittance decreased as shown in FIG. **4(c)**. Thus, it is desired that slit width S is more than 1.4 μm and less than 3.2 μm .

[0052] FIG. **5** shows the graphs representing T with constant slit width S and varying line width L. Graphs a, b, c, d, e, f, g, h, and i in FIG. **5** represent the relationship between line width L and T, with slit width S fixed at 1.4 μm , 1.8 μm , 2.1 μm , 2.5 μm , 2.8 μm , 3.2 μm , 3.5 μm , 4.2 μm , and 5.0 μm , respectively. Line width L was changed in the range of 1.4 μm to 8.0 μm .

[0053] As seen from FIG. **5**, the dependence of T on line width L was not so great. When slit width S was not less than 2.1 μm and not more than 2.8 μm (corresponding to c, d, and e in FIG. **5**), T was 90% or higher irrespective of the value of line width L. When slit width S was 1.4 μm or not less than 3.2 μm (corresponding to a, f, g, h, and i), T did not exceed 90% irrespective of the value of line width L. When slit width S was 1.8 μm (corresponding to b), T exceeded 90% so long as line width L was not less than 1.4 μm and not more than 3.5 μm .

[0054] Thus, to obtain desirable display with a small brightness variation, the pixel electrode need to be configured such that line width L is not less than 1.4 μm and not more than 8.0 μm , and slit width S is at least more than 1.4 μm and less than 3.2 μm . In other words, any adjacent two of the plurality of branch portions **30c** of the pixel electrode **30** and any adjacent two of the plurality of branch portions **30d** need to be separated by a space wider than 1.4 μm and narrower than 3.2 μm .

[0055] FIG. **6** shows the white display of the pixels **10**. FIG. **6(a)** shows a preferable display state achieved when both line width L and slit width S were 2.5 μm . FIG. **6(b)** and FIG. **6(c)** show unpreferable display states which are described below.

[0056] When line width L was less than 1.4 μm and slit width S was not more than 3.2 μm , the alignment control force produced by the slit portion was greater than the alignment control force produced by the line portion (trunk portion), so that abnormal alignment of the liquid crystal occurred, and the transmittance decreased as shown in FIG. **6(b)**. When line width L was more than 8.0 μm and slit width S was not more than 3.2 μm , the alignment control force produced by the line portion was greater than the alignment control force produced by the slit portion, so that abnormal alignment of the liquid crystal occurred, and the transmittance became nonuniform and decreased as shown in FIG. **6(c)**. Thus, line width L was preferably set to be not less than 1.4 μm and not more than 8.0 μm .

[0057] FIG. **7** is a table of the numerical representations of the transmittance variation degree T shown in FIG. **3** and FIG. **5**, showing all the values for T which resulted from the combinations of line width L and slit width S.

[0058] As seen from FIG. 7, when slit width S was more than 1.4 μm and less than 2.1 μm while line width L was not less than 1.4 μm and not more than 3.5 μm , or when slit width S was more than 1.8 μm and less than 3.2 μm while line width L was not less than 1.4 μm and not more than 8.0 μm , T was about 90% or higher. In other words, a desirable high transmittance was obtained when any adjacent two of the plurality of branch portions 30c of the pixel electrode 30 and any adjacent two of the plurality of branch portions 30d were separated by a space wider than 1.4 μm and narrower than 2.1 μm while width L of the branch portions 30c and the branch portions 30d was not less than 1.4 μm and not more than 3.5 μm , or when any adjacent two of the plurality of branch portions 30c and any adjacent two of the plurality of branch portions 30d were separated by a space wider than 1.8 μm and narrower than 3.2 μm while width L of the branch portions 30c and the branch portions 30d was not less than 1.4 μm and not more than 8.0 μm .

[0059] Note that T of 90% or higher is ensured by configuring the pixel electrode such that slit width S is not less than 1.8 μm and not more than 2.1 μm while line width L is not less than 1.4 μm and not more than 3.5 μm , or such that slit width S is not less than 2.1 μm and not more than 2.8 μm while line width L is not less than 1.4 μm and not more than 8.0 μm .

(Examination 2)

[0060] Next, the relation of the combination of line width L and slit width S to the display quality (degree of roughness) was examined based on the evaluations by viewer's visual observation.

[0061] FIG. 8 is a table which shows the display quality evaluations by observers with line width L varying in the range of 1.4 μm to 8.0 μm and slit width S varying in the range of 1.4 μm to 5.0 μm . In the table, "○" means that the display quality was at a satisfactory level, and "x(*)" and "xx(*)" mean that the display quality was insufficient for a desired level. More specifically, "○" means that no variation in pixel transmittance occurred across the entire display screen so that no roughness was observed in display. "x(*)" means that transmittance abnormality occurred in about 10 out of 100 pixels so that roughness was observed. "xx(*)" means that transmittance abnormality occurred in substantially all of the pixels so that terrible roughness was observed.

[0062] Conceivable causes of occurrence of roughness are explained as follows. When slit width S is far less than line width L, the alignment control force is insufficient near the slit portion so that the alignment of some liquid crystal molecules in the pixel becomes unfixed. When slit width S exceeds a certain value, the alignment control force is not sufficiently exerted on the liquid crystal molecules near the center of the slit portion so that the alignment of these liquid crystal molecules becomes unstable (see FIGS. 4(b) and 4(c) and FIGS. 6(b) and 6(c)).

[0063] As appreciated from FIG. 8, there is a probability that excellent display quality with no occurrence of roughness can be obtained when slit width S is more than 1.4 μm and less than 3.2 μm so long as line width L is in a range not less than 1.4 μm and not more than 5.0 μm . In other words, excellent display quality can be obtained when any adjacent two of the branch portions 30c and any adjacent two of the branch portions 30d are separated by a space wider than 1.4 μm and narrower than 3.2 μm so long as the width of each of the branch portions 30c and 30d is in a range not less than 1.4 μm and not more than 5.0 μm .

[0064] Excellent display quality can also be obtained when slit width S is more than 1.4 μm and less than 2.1 μm while line width L is in a range not less than 1.4 μm and not more than 3.2 μm , or when slit width S is not less than 2.1 μm and less than 3.2 μm while line width L is not less than 1.4 μm and not more than 5.0 μm . In other words, excellent display quality can be obtained when any adjacent two of the branch portions 30c and any adjacent two of the branch portions 30d are separated by a space wider than 1.4 μm and narrower than 2.1 μm while the width of each of the branch portions 30c and 30d is not less than 1.4 μm and not more than 3.2 μm , or when any adjacent two of the branch portions 30c and any adjacent two of the branch portions 30d are separated by a space equal to or wider than 2.1 μm and narrower than 3.2 μm while the width of each of the branch portions 30c and 30d is in a range not less than 1.4 μm and not more than 5.0 μm .

[0065] Also, excellent display quality is ensured so long as slit width S is not less than 1.8 μm and less than 2.1 μm while line width L is not less than 1.4 μm and not more than 3.2 μm , or when slit width S is not less than 2.1 μm and not more than 2.8 μm while line width L is not less than 1.4 μm and not more than 5.0 μm . In other words, excellent display quality can be ensured when any adjacent two of the branch portions 30c and any adjacent two of the branch portions 30d are separated by a space equal to or wider than 1.8 μm and narrower than 2.1 μm while the width of each of the branch portions 30c and 30d is in a range not less than 1.4 μm and not more than 3.2 μm , or when any adjacent two of the branch portions 30c and any adjacent two of the branch portions 30d are separated by a space equal to or wider than 2.1 μm and equal to or narrower than 2.8 μm while the width of each of the branch portions 30c and 30d is in a range not less than 1.4 μm and not more than 5.0 μm .

(Conclusion)

[0066] In consideration of the results of examinations 1 and 2, the optimum combinations of line width L and slit width S with which the variation in transmittance is sufficiently suppressed and roughness in display does not occur are shown

below.

[0067] (1) Line width L is in a range not less than 1.4 μm and not more than 5.0 μm , and slit width S is more than 1.8 μm and less than 3.2 μm . In other words, the width of each of the branch portions **30c** and **30d** is in a range not less than 1.4 μm and not more than 5.0 μm , and any adjacent two of the branch portions **30c** and any adjacent two of the branch portions **30d** are separated by a space wider than 1.8 μm and narrower than 3.2 μm .

[0068] (2) Line width L is in a range not less than 1.4 μm and not more than 3.2 μm , and slit width S is more than 1.4 μm and not more than 1.8 μm . In other words, the width of each of the branch portions **30c** and **30d** is in a range not less than 1.4 μm and not more than 3.2 μm , and any adjacent two of the branch portions **30c** and any adjacent two of the branch portions **30d** are separated by a space wider than 1.4 μm and equal to or narrower than 1.8 μm .

[0069] It is appreciated from the results of examination 1, the combination of line width L and slit width S which achieves the most excellent display (T=100%) is such that both line width L and slit width S are more than 2.1 μm and less than 2.8 μm . It is also appreciated from examination 2 that, in this case, excellent display quality with no roughness can be obtained. Thus, the most preferable display characteristics can be obtained so long as both line width L and slit width S are within this range. In other words, the best display characteristics can be obtained so long as the width of each of the branch portions **30c** and **30d** is in a range more than 2.1 μm and less than 2.8 μm while any adjacent two of the branch portions **30c** and any adjacent two of the branch portions **30d** are separated by a space wider than 2.1 μm and narrower than 2.8 μm .

[0070] Note that the shape of the pixel electrode **30** of embodiment 1 may be applied to the shape of the counter electrode within one pixel area. With such a counter electrode shape, equivalent effects to those described above can be obtained.

(Embodiment 2)

[0071] Hereinafter, a liquid crystal display device of embodiment 2 of the present invention is described. The liquid crystal display device of embodiment 2 is different from the liquid crystal display device of embodiment 1 in that the pixel electrode **30** of embodiment 1 is replaced by a pixel electrode of a different fishbone shape, and the other elements are the same as those of embodiment 1. Therefore, only the pixel electrode is described below.

[0072] FIG. 9 is a plan view schematically showing the structure of a pixel electrode **90** in one of a plurality of pixels arranged in the liquid crystal display device of embodiment 2 (pixel **10'**).

[0073] As shown in FIG. 9, the pixel electrode **90** includes trunk portions **90a** and **90a'** extending in the direction of azimuthal angle 0° - 180° , trunk portions **90b** and **90b'** extending in the direction of azimuthal angle 90° - 270° , a plurality of branch portions **90c** and **90c'** (first branch portions) extending in the direction of azimuthal angle 45° - 225° (first direction), and a plurality of branch portions **90d** and **90d'** (second branch portions) extending in the direction of azimuthal angle 135° - 315° (second direction). The branch portions **90c** and the branch portions **90d** branches off from the trunk portion **90a** or the trunk portion **90b**. The branch portions **90c'** and the branch portions **90d'** branches off from the trunk portion **90a'** or the trunk portion **90b'**.

[0074] The pixel **10'** includes a first region **95** and a second region **95'** which are separated by a virtual boundary line **97** extending in the direction of azimuthal angle 0° - 180° . In other words, the first region **95** and the second region **95'** are separated by a line (boundary line **97**) which is parallel or perpendicular to the mutually-orthogonal transmission axes of the two polarizing plates **60a** and **60b** shown in FIG. 2.

[0075] The first region **95** includes the trunk portions **90a** and **90b** and the branch portions **90c** and **90d**. The second region **95'** includes the trunk portions **90a'** and **90b'** and the branch portions **90c'** and **90d'**. In the first region **95**, widths L1 (first line widths) of the branch portions **90c** and **90d** are all equal. In the second region **95'**, widths L2 (second line widths) of the branch portions **90c'** and **90d'** are all equal. Note that width L1 and width L2 are different.

[0076] In the first region **95**, any adjacent two of the branch portions **90c** are separated by space S1 (first slit width), and any adjacent two of the branch portions **90d** are also separated by space S1. In the second region **95'**, any adjacent two of the branch portions **90c'** are separated by space S2 (second slit width) that is different from space S1, and any adjacent two of the branch portions **90d'** are also separated by space S2.

[0077] The pixel electrode **90** having the above-described structure realizes a multidomain of 4D structure in each of the first region **95** and the second region **95'**. Width L1 and width L2 are both set within the preferable range of width L which has been previously described in embodiment 1. Space S1 and space S2 are both set within the preferable range of space S which has been previously described in embodiment 1.

[0078] Since width L1 and width L2 are different and space S1 and space S2 are different, there is a small difference of the liquid crystal alignment control force between the first region and the second region. However, these widths and spaces are all within the ranges examined in embodiment 1, and therefore, the liquid crystal display device of embodiment 2 provides equivalent effects to those described in embodiment 1. The liquid crystal display device of embodiment 2 further provides the effects described below.

[0079] Now, consider the relationship between the voltage supplied to the pixel electrode and the transmittance. The

voltage dependence of the transmittance (referred to as "T-V characteristic") varies according to the shape of the pixel electrode. Therefore, the first region 95 and the second region 95' acquire two different T-V characteristics, and the one whole pixel 10' acquires the average of the two T-V characteristics.

[0080] In general, the T-V characteristic achieved by a pixel electrode having a specific shape is different from an ideal T-V characteristic, and therefore, defects such as whitish or blackish dots can occur in display. Also, the viewing angle dependence of the T-V characteristic varies according to the pixel shape, and therefore, it is probable that a pixel electrode having some specific shape cannot achieve a desired viewing angle characteristic.

[0081] In the liquid crystal display device of embodiment 2, one pixel can acquire two different T-V characteristics and perform display according to the average of these T-V characteristics. Therefore, more ideal gray scale and viewing angle characteristics can be obtained by appropriate combination of the pixel electrode shapes of the first region and the second region, in other words, by appropriate setting of width L1, width L2, space S1, and space S2.

[0082] A conceivable variation of the pixel electrode 90 includes, in the first region or the second region, trunk portions of two different widths, width L1 and width L2, and slit portions of two different spaces, space S1 and space S2. In this case, the trunk portions of two widths and the slit portions of two spaces exist adjacent to each other, so that the probability of abnormal alignment of the liquid crystal increases at the boundary between them. Thus, the two types of branch portions and the two types of slit portions should be in different regions as described in embodiment 2.

[0083] As is the case with embodiment 1, the shape of the pixel electrode 10' of embodiment 2 may be applied to the shape of the counter electrode within one pixel area. In this case also, equivalent effects to those described above can be obtained.

INDUSTRIAL APPLICABILITY

[0084] The present invention is preferably used in liquid crystal display devices of which high display quality is required.

Claims

1. A vertical alignment type liquid crystal display device which has a plurality of pixels, comprising:
 - a first electrode which includes, in each of the plurality of pixels, a plurality of first branch portions extending in a first direction and a plurality of second branch portions extending in a second direction that is different from the first direction;
 - a second electrode disposed so as to oppose the first electrode; and
 - a liquid crystal layer interposed between the first electrode and the second electrode,
 wherein a width of each of the plurality of first branch portions and the plurality of second branch portions is in a range not less than 1.4 μm and not more than 8.0 μm .
2. The liquid crystal display device of claim 1, wherein any adjacent two of the plurality of first branch portions and any adjacent two of the plurality of second branch portions are separated by a space wider than 1.4 μm and narrower than 3.2 μm .
3. The liquid crystal display device of claim 2, wherein when any adjacent two of the plurality of first branch portions and any adjacent two of the plurality of second branch portions are separated by a space wider than 1.4 μm and narrower than 2.1 μm , the width of each of the plurality of first branch portions and the plurality of second branch portions is in a range not less than 1.4 μm and not more than 3.5 μm .
4. The liquid crystal display device of claim 2, wherein the width of each of the plurality of first branch portions and the plurality of second branch portions is in a range not less than 1.4 μm and not more than 5.0 μm .
5. The liquid crystal display device of claim 4, wherein when any adjacent two of the plurality of first branch portions and any adjacent two of the plurality of second branch portions are separated by a space wider than 1.4 μm and narrower than 2.1 μm , the width of each of the plurality of first branch portions and the plurality of second branch portions is in a range not less than 1.4 μm and not more than 3.2 μm .
6. The liquid crystal display device of claim 1, wherein

the width of each of the plurality of first branch portions and the plurality of second branch portions is in a range not less than 1.4 μm and not more than 5.0 μm while any adjacent two of the plurality of first branch portions and any adjacent two of the plurality of second branch portions are separated by a space wider than 1.8 μm and narrower than 3.2 μm , or

the width of each of the plurality of first branch portions and the plurality of second branch portions is in a range not less than 1.4 μm and not more than 3.2 μm while any adjacent two of the plurality of first branch portions and any adjacent two of the plurality of second branch portions are separated by a space wider than 1.4 μm and equal to or narrower than 1.8 μm .

7. The liquid crystal display device of any one of claims 1 to 6, wherein the width of each of the plurality of first branch portions and the plurality of second branch portions is in a range more than 2.1 μm and less than 2.8 μm while any adjacent two of the plurality of first branch portions and any adjacent two of the plurality of second branch portions are separated by a space wider than 2.1 μm and narrower than 2.8 μm .

8. The liquid crystal display device of any one of claims 1 to 7, wherein the first electrode includes a trunk portion, the plurality of first branch portions extend from the trunk portion in the first direction, and the plurality of second branch portions extend from the trunk portion in the second direction.

9. The liquid crystal display device of any one of claims 1 to 8, further comprising a pair of polarizing plates which have transmission axes orthogonal to each other, wherein the first direction and the second direction are orthogonal to each other, and directions of the transmission axes of the pair of polarizing plates and the first direction are different by 45°, 135°, 225°, or 315°.

10. The liquid crystal display device of claim 9, wherein each of the plurality of pixels includes a first region and a second region which are separated by a line parallel to or perpendicular to the directions of the transmission axes of the pair of polarizing plates, each of the first region and the second region includes the plurality of first branch portions and the plurality of second branch portions, each of the plurality of first branch portions in the first region has a first width, and each of the plurality of first branch portions in the second region has a second width that is different from the first width.

11. The liquid crystal display device of claim 10, wherein each of the plurality of second branch portions in the first region has the first width, and each of the plurality of second branch portions in the second region has the second width.

12. The liquid crystal display device of claim 10 or 11, wherein any adjacent two of the plurality of first branch portions in the first region are separated by a first space, and any adjacent two of the plurality of first branch portions in the second region are separated by a second space that is different from the first space.

13. The liquid crystal display device of claim 12, wherein any adjacent two of the plurality of second branch portions in the first region are separated by the first space, and any adjacent two of the plurality of second branch portions in the second region are separated by the second space.

FIG. 1

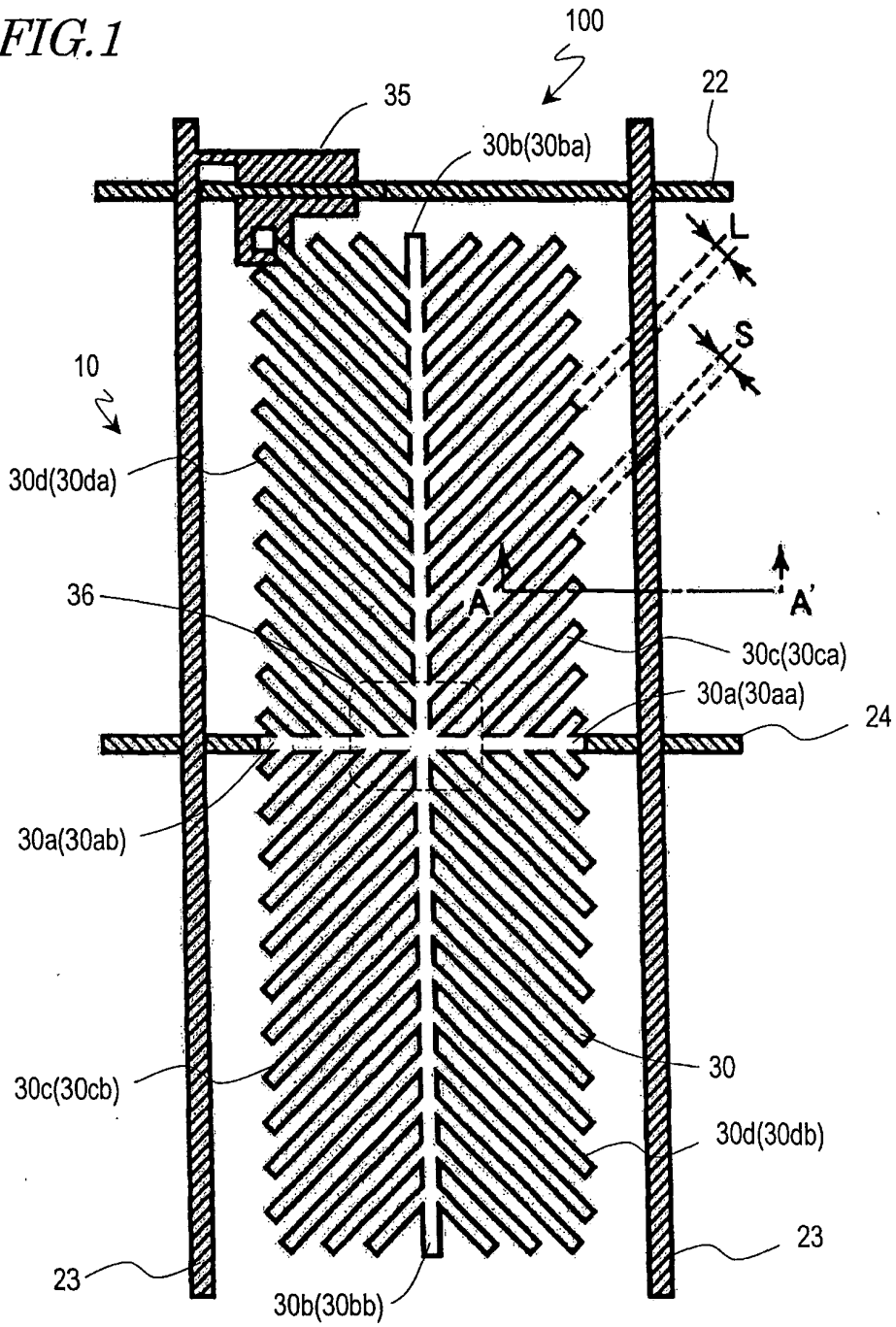

FIG.2

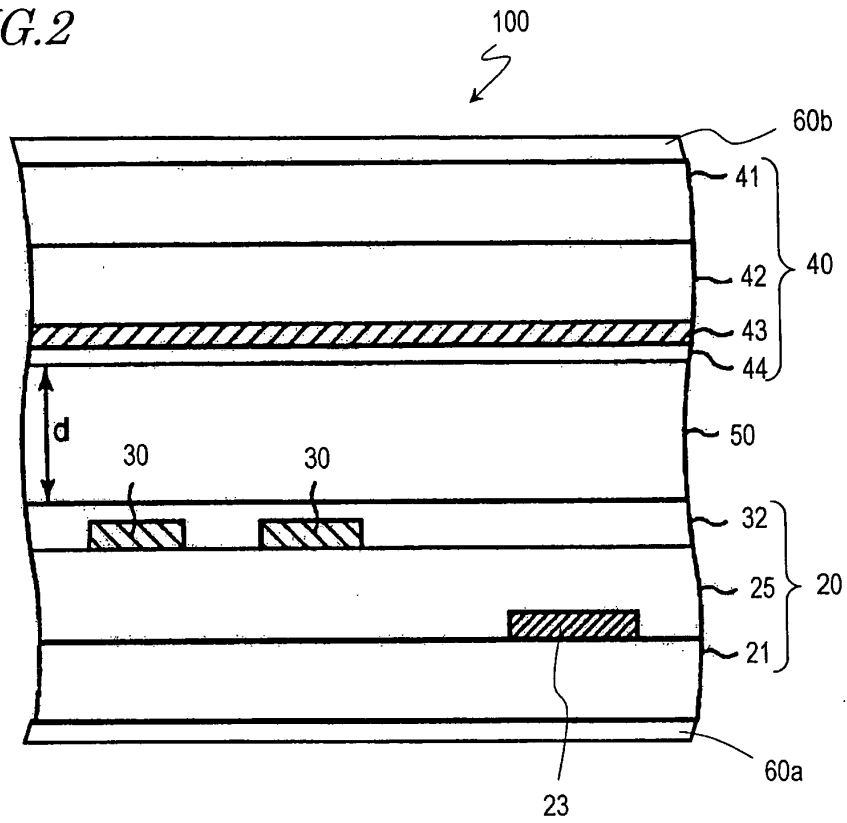

FIG.3

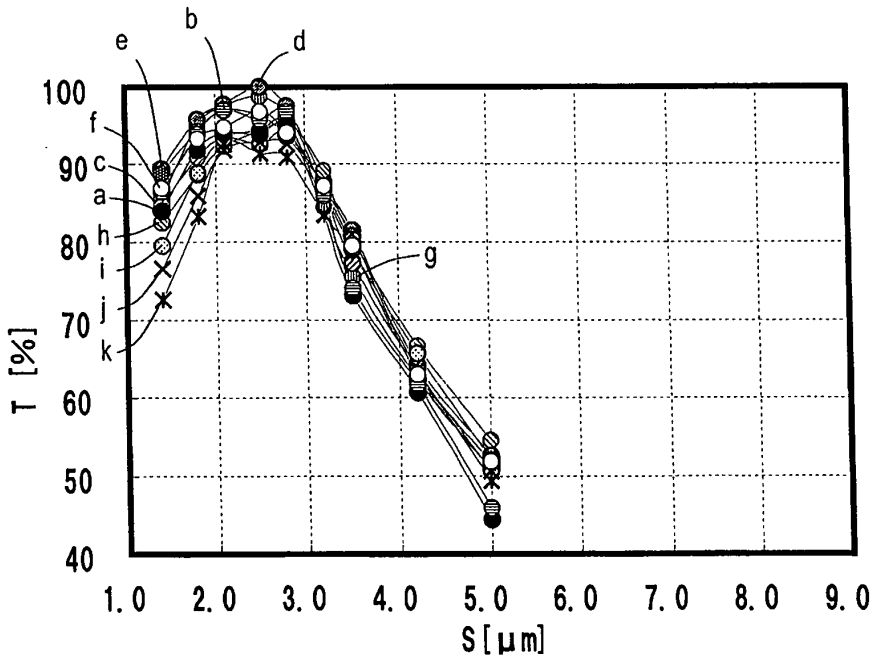

FIG. 4

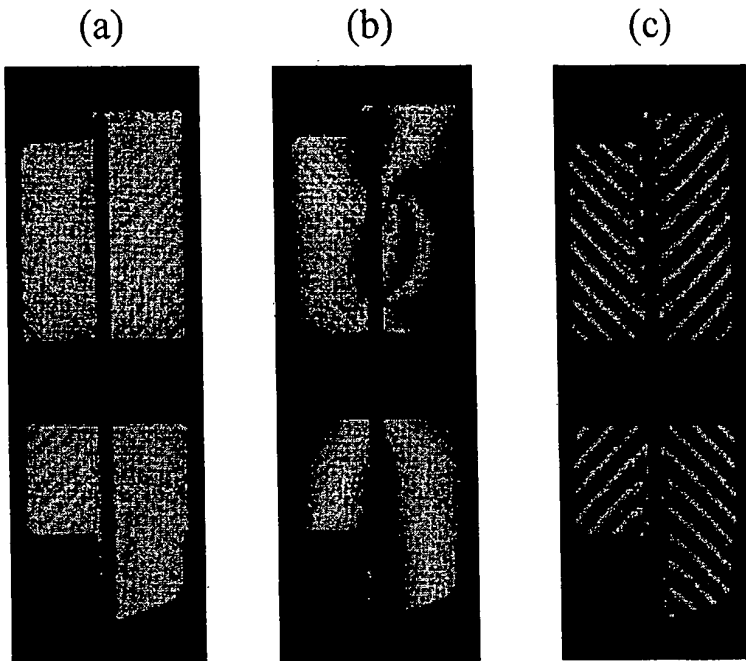

FIG. 5

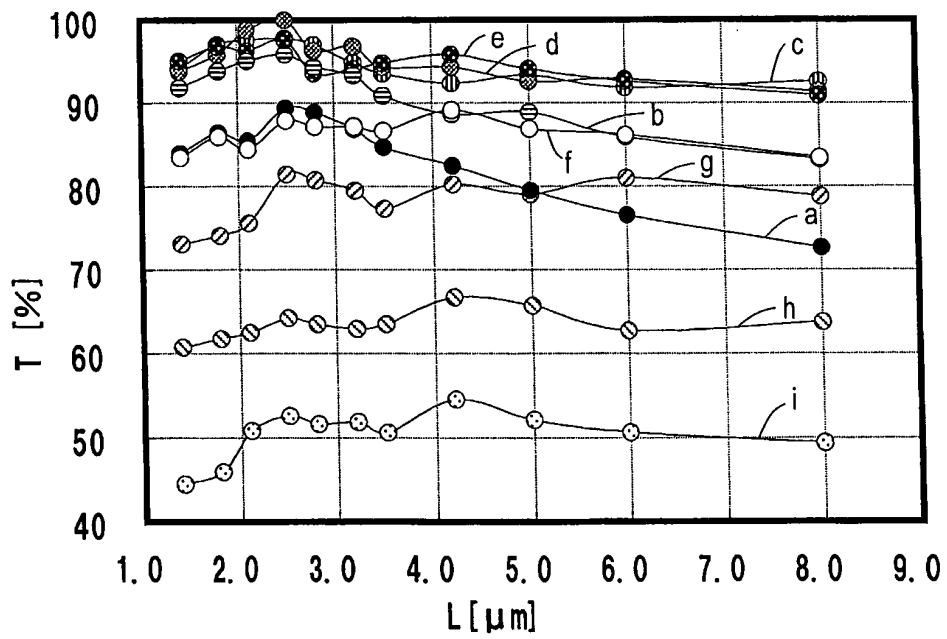

FIG. 6

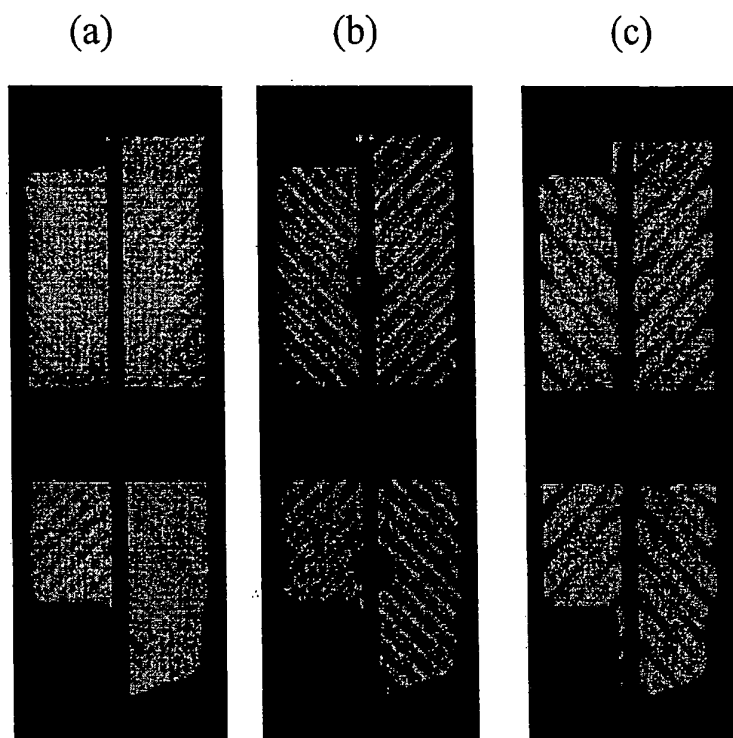

FIG. 7

L[μm]	S[μm]								
	1.4	1.8	2.1	2.5	2.8	3.2	3.5	4.2	5.0
1.4	84.0	91.9	94.1	93.8	95.1	83.5	73.1	60.7	44.4
1.8	86.4	93.8	97.0	95.8	96.8	85.9	74.1	61.7	45.9
2.1	85.4	95.1	97.5	98.8	96.3	84.4	75.6	62.5	50.9
2.5	89.4	95.8	97.8	100.0	97.5	87.9	81.5	64.2	52.6
2.8	88.9	94.3	97.0	96.3	93.6	87.2	80.7	63.5	51.6
3.2	86.9	93.3	94.8	96.8	94.1	87.2	79.5	63.0	51.9
3.5	84.7	90.9	93.6	94.3	94.8	86.7	77.3	63.5	50.6
4.2	82.5	88.6	92.3	94.3	95.8	89.1	80.2	66.7	54.6
5.0	79.5	88.9	93.3	92.6	94.1	86.9	79.0	65.7	52.1
6.0	76.5	85.9	91.9	92.8	92.6	86.2	81.0	62.7	50.6
8.0	72.6	83.2	92.6	91.4	90.9	83.5	78.8	63.7	49.4

FIG.8

L[μ m]	S[μ m]								
	1.4	1.8	2.1	2.5	2.8	3.2	3.5	4.2	5.0
1.4	××(1)	○	○	○	○	×(2)	××(2)	××(2)	××(2)
1.8	××(1)	○	○	○	○	×(2)	××(2)	××(2)	××(2)
2.1	××(1)	○	○	○	○	×(2)	××(2)	××(2)	××(2)
2.5	××(1)	○	○	○	○	×(2)	××(2)	××(2)	××(2)
2.8	××(1)	○	○	○	○	×(2)	××(2)	××(2)	××(2)
3.2	××(1)	○	○	○	○	×(2)	××(2)	××(2)	××(2)
3.5	××(1)	×(1)	○	○	○	×(2)	××(2)	××(2)	××(2)
4.2	××(1)	×(1)	○	○	○	×(2)	××(2)	××(2)	××(2)
5.0	××(1)	×(1)	○	○	○	×(2)	××(2)	××(2)	××(2)
6.0	××(1)	×(1)	×(1)	×(1)	×(1)	×(2)	××(2)	××(2)	××(2)
8.0	××(1)	×(1)	×(1)	×(1)	×(1)	×(1)	××(2)	××(2)	××(2)

FIG. 9

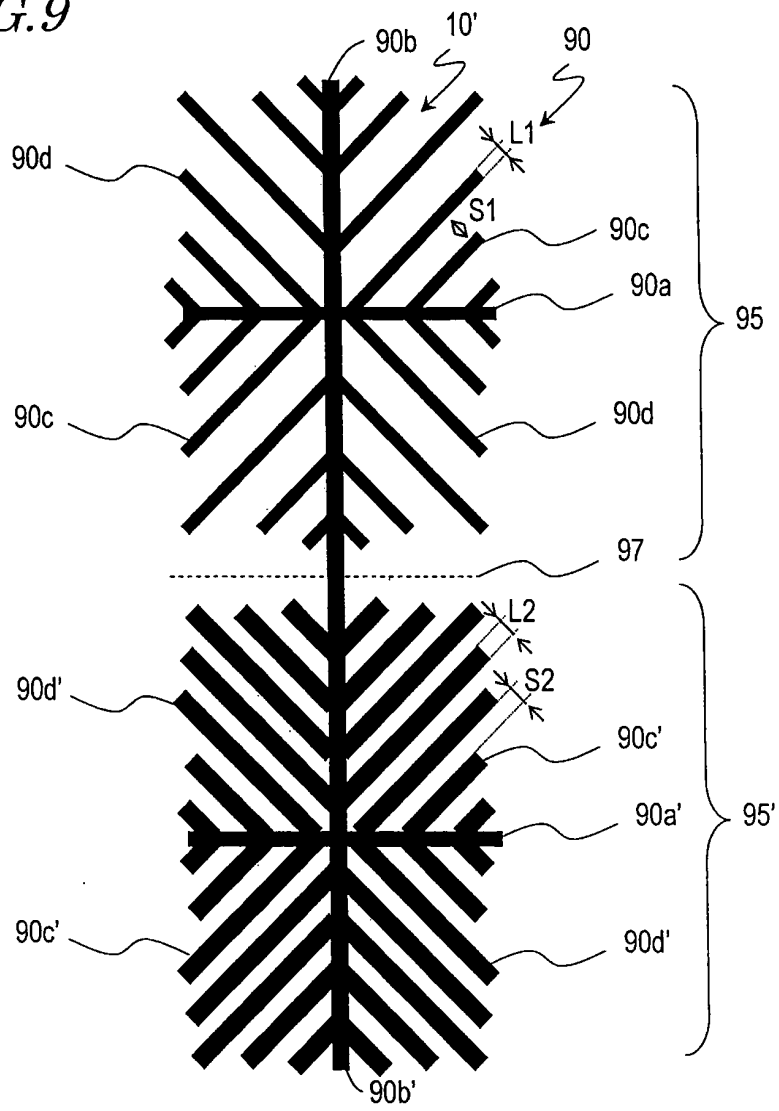

INTERNATIONAL SEARCH REPORT

International application No.

PCT/JP2008/003722

A. CLASSIFICATION OF SUBJECT MATTER G02F1/1337(2006.01)i, G02F1/1343(2006.01)i		
According to International Patent Classification (IPC) or to both national classification and IPC		
B. FIELDS SEARCHED		
Minimum documentation searched (classification system followed by classification symbols) G02F1/1337, G02F1/1343		
Documentation searched other than minimum documentation to the extent that such documents are included in the fields searched Jitsuyo Shinan Koho 1922-1996 Jitsuyo Shinan Toroku Koho 1996-2009 Kokai Jitsuyo Shinan Koho 1971-2009 Toroku Jitsuyo Shinan Koho 1994-2009		
Electronic data base consulted during the international search (name of data base and, where practicable, search terms used)		
C. DOCUMENTS CONSIDERED TO BE RELEVANT		
Category*	Citation of document, with indication, where appropriate, of the relevant passages	Relevant to claim No.
X Y	JP 2003-149647 A (Fujitsu Display Technologies Corp.), 21 May, 2003 (21.05.03), Par. Nos. [0009] to [0011], [0015] to [0066] & TW 571154 B & KR 10-2003-0019080 A & CN 1403859 A & CN 1601357 A & KR 10-2007-0072838 A	1-9 10-13
Y	JP 2003-177418 A (Fujitsu Display Technologies Corp.), 27 June, 2003 (27.06.03), Par. Nos. [0081] to [0087]; Figs. 32 to 34 & US 2003/0086044 A1 & US 2005/0253988 A1 & TW 567358 B & KR 10-2003-0028701 A & CN 1410808 A & CN 1573458 A & CN 1924678 A	10-13
<input type="checkbox"/> Further documents are listed in the continuation of Box C. <input type="checkbox"/> See patent family annex.		
* Special categories of cited documents: "A" document defining the general state of the art which is not considered to be of particular relevance "E" earlier application or patent but published on or after the international filing date "L" document which may throw doubts on priority claim(s) or which is cited to establish the publication date of another citation or other special reason (as specified) "O" document referring to an oral disclosure, use, exhibition or other means "P" document published prior to the international filing date but later than the priority date claimed	"T" later document published after the international filing date or priority date and not in conflict with the application but cited to understand the principle or theory underlying the invention "X" document of particular relevance; the claimed invention cannot be considered novel or cannot be considered to involve an inventive step when the document is taken alone "Y" document of particular relevance; the claimed invention cannot be considered to involve an inventive step when the document is combined with one or more other such documents, such combination being obvious to a person skilled in the art "&" document member of the same patent family	
Date of the actual completion of the international search 14 January, 2009 (14.01.09)	Date of mailing of the international search report 27 January, 2009 (27.01.09)	
Name and mailing address of the ISA/ Japanese Patent Office	Authorized officer	
Facsimile No.	Telephone No.	

REFERENCES CITED IN THE DESCRIPTION

This list of references cited by the applicant is for the reader's convenience only. It does not form part of the European patent document. Even though great care has been taken in compiling the references, errors or omissions cannot be excluded and the EPO disclaims all liability in this regard.

Patent documents cited in the description

- JP 2002107730 A [0010]
- JP 2003149647 A [0010]
- JP 2006330638 A [0010]

专利名称(译)	液晶显示装置		
公开(公告)号	EP2224283A1	公开(公告)日	2010-09-01
申请号	EP2008867596	申请日	2008-12-11
[标]申请(专利权)人(译)	夏普株式会社		
申请(专利权)人(译)	夏普株式会社		
当前申请(专利权)人(译)	夏普株式会社		
[标]发明人	OHGAMI HIROYUKI HASHIMOTO YOSHITO SHIBASAKI MASAKAZU IYAMA YUICHI KUBO MASUMI SOGA MASAYUKI		
发明人	OHGAMI, HIROYUKI HASHIMOTO, YOSHITO SHIBASAKI, MASAKAZU IYAMA, YUICHI KUBO, MASUMI SOGA, MASAYUKI		
IPC分类号	G02F1/1337 G02F1/1343 G02F1/139		
CPC分类号	G02F1/134309 G02F1/133707 G02F1/1393		
代理机构(译)	津凯, THOMAS		
优先权	2007340854 2007-12-28 JP		
其他公开文献	EP2224283B1 EP2224283A4		
外部链接	Espacenet		

摘要(译)

本发明提供一种高画质，高亮度，小显示不均匀的液晶显示装置。一种具有多个像素的垂直取向型液晶显示装置，包括：第一电极，在所述多个像素的每一个中包括沿第一方向延伸的多个第一分支部分和延伸的多个第二分支部分。第二个方向与第一个方向不同；第二电极，设置成与第一电极相对；以及插入在第一电极和第二电极之间的液晶层，其中多个第一分支部分和多个第二分支部分中的每一个的宽度在不小于1.4μm且不大于8.0μm的范围内。

