

(19)



(11)

**EP 1 859 317 B1**

(12)

**EUROPEAN PATENT SPECIFICATION**

(45) Date of publication and mention of the grant of the patent:

**29.06.2016 Bulletin 2016/26**

(51) Int Cl.:

**G02F 1/1335 (2006.01)**

(21) Application number: **06716303.0**

(86) International application number:

**PCT/KR2006/000853**

(22) Date of filing: **10.03.2006**

(87) International publication number:

**WO 2006/107148 (12.10.2006 Gazette 2006/41)**

**(54) VERTICALLY ALLIGNED LIQUID CRYSTAL DISPLAY HAVING A WIDE VIEWING COMPENSATION FILM USING +A-FILM AND +C-FILM**

VERTIKAL AUSGERICHTETE FLÜSSIGKRISTALLANZEIGE MIT BREITER SICHTAUSGLEICHSFOLIE AUS +A-FILM UND +C-FILM

ECRAN A CRISTAUX LIQUIDES ALIGNES VERTICALEMENT A FILM DE COMPENSATION DES GRANDS ANGLES DE VUE, COMPOSE D'UN FILM +A ET D'UN FILM +B

(84) Designated Contracting States:

**DE FR GB**

(56) References cited:

<b>EP-A2- 1 353 214</b>	<b>WO-A-2004/068223</b>
<b>JP-A- 08 122 770</b>	<b>JP-A- 11 287 994</b>
<b>JP-A- 2002 055 342</b>	<b>JP-A- 2003 195 310</b>
<b>KR-A- 99 004 389</b>	<b>US-A1- 2001 048 497</b>
<b>US-A1- 2002 149 733</b>	

(30) Priority: **10.03.2005 KR 20050020183**

(43) Date of publication of application:

**28.11.2007 Bulletin 2007/48**

(73) Proprietor: **LG Chem, Ltd.**

**Youngdungpo-gu, Seoul 150-721 (KR)**

(72) Inventors:

- **JEON, Byoung-kun,**  
203, Lg Dormitory New Yeollip.  
Daejeon Metropolitan City 305-340 (KR)
- **BELYAEV, Sergey,**  
6-201, Lg Chemistry Dormitory  
Daejeon Metropolitan City 305-340 (KR)
- **MALIMONENKO, Nikolay,**  
6-203, Lg Chemistry Dormitory  
Daejeon Metropolitan City 305-340 (KR)
- **CHANG, Jun-won,**  
103, Lg Chemistry New Yeollip.  
Daejeon Metropolitan City 305-340 (KR)
- **JANG, Soo-jin,**  
103-803, Seongnae 1-cha, E-pyenhan  
Seoul 134-842 (KR)

- **HOURYU T ET AL:** "Optical Compensation of a MVA-LCD with Circular Polarizers" IDW, LCPT1 - 5, FUKUOKA JP, December 2003 (2003-12), pages 121-124, XP007016041
- **OHMURA K ET AL:** "33.3: DEVELOPMENT OF SUPER-HIGH-IMAGE-QUALITY VERTICAL-ALIGNMENT-MODE LCD" 13 May 1997 (1997-05-13), 1997 SID INTERNATIONAL SYMPOSIUM DIGEST OF TECHNICAL PAPERS. BOSTON, MAY 13 - 15, 1997; [SID INTERNATIONAL SYMPOSIUM DIGEST OF TECHNICAL PAPERS], SANTA ANA, SID, US, PAGE(S) 845 - 848 , XP000722823 \* the whole document \*
- **CHEN J ET AL:** "Optimum film compensation modes for TN and VA LCDs" 1 January 1998 (1998-01-01), JOURNAL OF THE SOCIETY FOR INFORMATION DISPLAY - SID, SOCIETY FOR INFORMATION DISPLAY, PAGE(S) 315 - 318 , XP002284819 ISSN: 1071-0922 \* figure 5 \*

(74) Representative: **Hoffmann Eitle**

**Patent- und Rechtsanwälte PartmbB**  
**Arabellastraße 30**  
**81925 München (DE)**

**EP 1 859 317 B1**

Note: Within nine months of the publication of the mention of the grant of the European patent in the European Patent Bulletin, any person may give notice to the European Patent Office of opposition to that patent, in accordance with the Implementing Regulations. Notice of opposition shall not be deemed to have been filed until the opposition fee has been paid. (Art. 99(1) European Patent Convention).

**Description****Technical Field**

5 [0001] The present invention relates, generally, to a liquid crystal display (LCD), and more particularly, to a vertically aligned LCD (hereinafter, referred to as "VA-LCD"), filled with liquid crystals having negative dielectric anisotropy ( $\Delta\epsilon < 0$ ), having a wide viewing angle compensation film using a +A-film and +C-film to improve contrast properties at surface-facing angle and tilt angle and to minimize a color shift depending on the viewing angle in a dark state so as to improve wide viewing angle properties.

**Background Art**

10 [0002] Typically, LCDs, which have recently become widely used in the flat display field, suffer because they have a narrow viewing angle. The reasons why an image is differently displayed depending on the viewing angle in LCDs are that, first, there are problems related to the anisotropy of liquid crystals, and, second, a polarizing plate is deficient.

15 [0003] Thus, in order to improve a wide viewing angle of an LCD, a completely dark state and uniform brightness are required. In particular, the VA-LCD, in which the initial orientation of liquid crystals is in the vertical direction, unlike a TN mode, has two problems in regard to deteriorating viewing angle properties, that is, first, the dependence of performance of perpendicular polarizing plates on the viewing angle, and second, the dependence of the birefringence of the VA-LCD panel on the viewing angle.

20 [0004] Various attempts have been made to overcome the obstacles preventing realization of a wide viewing angle of LCDs attributed to such requirements and problems. As specific techniques for improvement, a method of using a viewing angle compensation film for compensating for a narrow viewing angle by changing  $\Delta nd$  (multiplication of birefringence by thickness of a liquid crystal panel) depending on the angle, and a multidomain mode using a pixel, divided into a plurality of domains to improve a viewing angle, have been proposed.

25 [0005] As a specific example for improving the wide viewing angle of the VA-LCD using the viewing angle compensation film, a VA-LCD using a -C-plate compensation film ( $n_x = n_y > n_z$ , where  $n_x$  is the in-plane refractive index in the X-axis direction,  $n_y$  is the in-plane refractive index in the Y-axis direction, and  $n_z$  is the refractive index in the Z-axis direction, that is, the thickness direction) for compensating for the dark state of a VA-LCD when voltage is not applied is disclosed in US Patent No. 4,889,412. However, since the VA-LCD including only the -C-plate compensation film does not completely compensate therefor, light undesirably leaks at tilt angles.

30 [0006] In US Patent No. 6,141,075, a compensation film comprising a C-plate compensation film and an A-plate compensation film is disclosed, in which compensation for the dark state of the VA-LCD when voltage is not applied is said to be more efficiently realized than in other conventional cases. However, this patent suffers because the minimum contrast ratio at a tilt angle of  $70^\circ$  in a dark state is merely 20:1. Hence, to meet the goal of completely compensating for a viewing angle, contrast at surface-facing angle and tilt angle of LCDs should be improved, and the problem of color shift depending on the viewing angle in a dark state should be solved.

35 [0007] US 2001/048497 A1 describes a liquid crystal display which is as defined in the preamble of claim 1.

**Disclosure of Invention****Technical Problem**

40 [0008] Accordingly, the present invention has been devised to solve the problems mentioned above, and an object of the present invention is to provide a VA-LCD having an improved wide viewing angle by realizing high contrast properties at surface-facing angle and tilt angle of the VA-LCD due to minimum leakage of light in a dark state.

45 [0009] Another object of the present invention is to provide an achromatic VA-LCD capable of minimizing color shift depending on the viewing angle in a dark state.

50 [0010] The present inventors have found out that it is effective to use a +A-film and a +C-film so as to minimize the leakage of light in a dark state and to minimize a color shift in a dark state, and to compensate a viewing angle.

[0011] Further, they have found out that the +C-film should be disposed between a polarizing plate adjacent thereto and the +A-film, and that the optic axis of the +A-film should be perpendicular to or parallel to the absorption axis of the adjacent polarizing plate. Furthermore, the in-plane or thickness retardation value of the +A-film and +C-film has been found to vary with the retardation value of the internal protective film of the polarizing plate.

55 [0012] Based on the above facts, the present invention is characterized in that one or more +A-films and +C-films are appropriately disposed between the polarizing plate and the VA-panel, such that the leakage of light in a dark state of the VA-LCD is minimized so as to achieve high contrast, and color shift depending on the viewing angle in a dark state is minimized.

**Technical Solution**

[0013] In order to accomplish the above objects, the present invention provides a VA-LCD using a +A-film and a +C-film as a wide viewing angle compensation film.

[0014] Specifically, the present invention provides a VA-LCD comprising a first polarizing plate and a second polarizing plate having absorption axes perpendicular to each other and a VA-panel provided therebetween and including vertically aligned liquid crystals having negative dielectric anisotropy, in which one or more first +A-films and one or more first +C-films are provided between the first polarizing plate and the VA-panel, the first +C-film is positioned between the first polarizing plate and the first +A-film, and the optic axis of the first +A-film is perpendicular to or parallel to the absorption axis of the first polarizing plate.

[0015] Further, in the structure of the VA-LCD having one or more first +A-films and first +C-films between the first polarizing plate and the VA-panel, a second +A-film is provided between the second polarizing plate and the VA-panel, or a second +A-film and a second +C-film are provided therebetween, and the optic axes of the first +A-film and the second +A-film are perpendicular to or parallel to the absorption axis of the respective adjacent polarizing plate.

[0016] In addition, the present invention provides a VA-LCD including a first +A-film and a first +C-film having a retardation value in a preferred range depending on the configuration of the optic axis of the first +A-film or second +A-film and whether the second +A-film or the second +C-film is included.

[0017] In addition, the present invention provides a VA-LCD using a film having no thickness retardation value or a negative thickness retardation value as an internal protective film of the polarizing plate affecting the viewing angle properties of the VA-LCD. In the VA-LCD according to the present invention, the +A-film or the +C-film may function as the internal protective film of the polarizing plate.

**Advantageous Effects**

[0018] According to the present invention, the VA-LCD is advantageous because it has improved contrast at surface-facing angle and tilt angle thereof and because a color shift depending on the viewing angle in a dark state can be minimized, thus greatly increasing the viewing angle of the VA-LCD.

**Brief Description of the Drawings**

[0019]

FIG. 1 is a view schematically showing the structure of a VA-LCD comprising a +A-film and a +C-film, according to a first embodiment of the present invention.

FIG. 2 is a view schematically showing the structure of a VA-LCD comprising a +A-film and a +C-film, according to a second embodiment of the present invention.

FIG. 3 is a view schematically showing the structure of a VA-LCD comprising two +A-films and a +C-film, according to a third embodiment of the present invention.

FIG. 4 is a view schematically showing the structure of a VA-LCD comprising two +A-films and a +C-film, according to a fourth embodiment of the present invention.

FIG. 5 is a view schematically showing the structure of a VA-LCD comprising two +A-films and two +C-films, according to a fifth embodiment of the present invention.

FIG. 6 is a view schematically showing the structure of a VA-LCD comprising two +A-films and two +C-films, according to a sixth embodiment of the present invention.

FIG. 7 is a view schematically showing the structure of a VA-LCD comprising two +A-films and two +C-films, according to a seventh embodiment of the present invention.

FIG. 8 is a view showing the result of simulation of the contrast ratio of the VA-LCD according to the first embodiment of the present invention when using white light and varying the tilt angle in the range of 0~80° at intervals of 2° with respect to the entire radius angle.

FIG. 9 is a view showing the result of simulation of the contrast ratio of the VA-LCD according to the second embodiment of the present invention when using white light and varying the tilt angle in the range of 0~80° at intervals of 2° with respect to the entire radius angle.

FIG. 10 is a view showing the result of simulation of the contrast ratio of the VA-LCD according to the third embodiment of the present invention when using white light and varying the tilt angle in the range of 0~80° at intervals of 2° with respect to the entire radius angle.

FIG. 11 is a view showing the result of simulation of the contrast ratio of the VA-LCD according to the fourth embodiment of the present invention when using white light and varying the tilt angle in the range of 0~80° at intervals of 2° with respect to the entire radius angle.

FIG. 12 is a view showing the result of simulation of the contrast ratio of the VA-LCD according to the fifth embodiment of the present invention when using white light and varying the tilt angle in the range of 0~80° at intervals of 2° with respect to the entire radius angle.

FIG. 13 is a view showing the result of simulation of the contrast ratio of the VA-LCD according to the sixth embodiment of the present invention when using white light and varying the tilt angle in the range of 0~80° at intervals of 2° with respect to the entire radius angle.

FIG. 14 is a view showing the result of simulation of the contrast ratio of the VA-LCD according to the seventh embodiment of the present invention when using white light and varying the tilt angle in the range of 0~80° at intervals of 2° with respect to the entire radius angle.

### Mode for the Invention

**[0020]** Hereinafter, a detailed description will be given of the present invention.

**[0021]** The LCD according to the present invention is a VA-LCD in which the optic axis of liquid crystals in a VA-panel is perpendicular to a polarizing plate. Particularly, the LCD of the present invention comprises a VA-panel in which liquid crystals having negative dielectric anisotropy ( $\Delta\epsilon < 0$ ) are filled between two substrates, and a first polarizing plate and a second polarizing plate that are disposed on respective sides of the VA-panel, in which the absorption axis of the first polarizing plate is perpendicular to the absorption axis of the second polarizing plate. Both the first polarizing plate and the second polarizing plate may have an internal protective film and an external protective film.

**[0022]** In the present invention, the VA-LCD preferably adopts an MVA (Multidomain Vertically Aligned) mode or a VA mode using a chiral additive. In addition, a cell gap of a liquid crystal cell consisting of the VA-panel preferably is 3~8  $\mu\text{m}$ .

**[0023]** In the present invention, one or more +A-films and one or more +C-films are disposed between the first and/or second polarizing plate and the VA-panel of the VA-LCD having the above structure. The structure of the VA-LCD for compensating for the wide viewing angle using the +A-film and +C-film according to the present invention should satisfy the following general requirements.

**[0024]** That is, the VA-panel is positioned between the first polarizing plate and second polarizing plate having absorption axes perpendicular to each other, a first +A-film and a first +C-film are positioned between the first polarizing plate and the VA-panel, the first +A-film is disposed adjacent to the VA-panel, and the first +C-film is disposed between the first +A-film and the polarizing plate.

**[0025]** In such a case, the optic axis of the first +A-film should be perpendicular to or parallel to the absorption axis of the first polarizing plate. Based on the configuration of the optic axis of the first +A-film perpendicular to or parallel to the absorption axis of the first polarizing plate, the in-plane retardation value of the first +A-film and the thickness retardation value of the first +C-film are changed, thus obtaining preferred embodiments having various structures.

**[0026]** The VA-LCD, which satisfies the above-mentioned requirements, may further comprise one or more second +A-films between the second polarizing plate and the VA-panel, or one or more second +A-films and one or more second +C-films between the second polarizing plate and the VA-panel. In such cases, the in-plane retardation value of the +A-film and the thickness retardation value of the +C-film vary depending on the direction of the optic axis of the +A-film disposed adjacent to the first polarizing plate and/or second polarizing plate, thus obtaining various preferred embodiments.

**[0027]** The retardation film of the +A-film and +C-film used as the viewing angle compensation film may be defined as follows.

**[0028]** When the refractive index in an x-axis direction of the in-plane refractive index is represented by  $n_x$ , the refractive index in a y-axis direction of the in-plane refractive index is represented by  $n_y$ , and the refractive index in a z-axis direction as a thickness direction is represented by  $n_z$ , the +A-film, which is used as a first type viewing angle compensation film, is as defined in Equation 1 below, and the +C-film, which is used as a second type viewing angle compensation film, is as defined in Equation 2 below:

Equation 1

$$n_x > n_y = n_z$$

Equation 2

$$n_x = n_y < n_z$$

**[0029]** As such, when the thickness of the film is represented by  $d$ , the in-plane retardation value is as defined in Equation 3 below, and the thickness retardation value is as defined in Equation 4 below.

Equation 3

$$R_{in} = (n_x - n_y) \times d$$

5

Equation 4

$$R_{th} = (n_z - n_y) \times d$$

10

**[0030]** Examples of +A-film having the in-plane refractive index properties mentioned above include a stretched cycloolefin polymer film, a stretched polycarbonate (PC) films, a horizontally aligned UV curing type liquid crystal film, etc. In addition, examples of +C-film having the thickness refractive index mentioned above include a vertically aligned UV curing type liquid crystal film.

**[0031]** Of the internal protective film and external protective film of the polarizing plate, the internal protective film of the polarizing plate affects the viewing angle properties of the VA-LCD, and in particular, the retardation value of the internal protective film greatly affects the viewing angle properties of the VA-LCD. Thus, the viewing angle compensation film of the VA-LCD should be designed in consideration of the retardation value of the internal protective film of the polarizing plate. In this way, the internal protective film of the polarizing plate is preferably exemplified by a film having no thickness retardation value, or having a negative thickness retardation value. Specific examples of the internal protective film of the polarizing plate include an unstretched cycloolefin polymer (COP) film having a retardation value close to 0, a triacetate cellulose (TAC) film having a retardation value of 0, a triacetate cellulose film and a polynorbornene (PNB) film having a negative retardation value, etc.

**[0032]** Further, in order to improve the wide viewing angle while simplifying the structure of the VA-panel of the VA-LCD of the present invention, the +A-film may be used as the internal protective film of the polarizing plate, or the +C-film may be used as the internal protective film of the polarizing plate.

**[0033]** Below, the preferred embodiments of the present invention are described with reference to the drawings.

**[0034]** FIG. 1 shows the structure of a VA-LCD having a +A-film and a +C-film, according to a first embodiment of the present invention, the major characteristics of which are as follows.

**[0035]** As shown in FIG. 1, a +A-film 7 and a +C-film 6 are disposed between a first polarizing plate 1 and a VA-LCD panel 5, and the +C-film 6 is disposed between the first polarizing plate 1 and the +A-film 7. That is, the +A-film 7 is disposed adjacent to the VA-LCD panel 5.

**[0036]** As such, the optic axis 8 of the +A-film 7 is perpendicular to the absorption axis 2 of the first polarizing plate 1 that is disposed adjacent thereto.

**[0037]** In the VA-LCD according to the first embodiment, with the aim of minimizing the leakage of light in a dark state, the in-plane retardation value of the +A-film 7 preferably ranges from 130 nm to 300 nm at a wavelength of 550 nm, and the thickness retardation value of the +C-film 6 preferably ranges from 10 nm to 400 nm at a wavelength of 550 nm.

**[0038]** Examples of the internal protective film of the polarizing plate include an unstretched cycloolefin polymer (COP) film having a retardation value close to 0, a triacetate cellulose (TAC) film having a retardation value of 0, a triacetate cellulose film and a polynorbornene (PNB) film having a negative retardation value, etc.

**[0039]** Examples of the +A-film 7 include a stretched cycloolefin polymer film, a stretched polycarbonate (PC) film, a horizontally aligned UV curing type liquid crystal film, etc. In addition, examples of the +C-film 6 include a vertically aligned UV curing type liquid crystal film. The +C-film 6 may be used as the internal protective film of the polarizing plate.

**[0040]** In Table 1 below are summarized the results of simulation of the contrast properties at a tilt angle of 70° performed while varying each of the following conditions: a) the retardation value of the +A-film 7, b) the retardation value of the +C-film 6, and c) the type of internal protective film of the first polarizing plate 1 and the second polarizing plate 3, which are design values for practical retardation films disposed as in FIG. 1.

Table 1

Internal Protective Film of 2nd Polarizing Plate (Retardation Value)	Retardation Value of VA-Panel	+A-Film (Retardation Value)	+ C-Film (Retardation Value)	Internal Protective Film of 1st Polarizing Plate (Retardation Value)	Minimum Contrast Ratio at Tilt Angle of 70°
COP (0nm)	330nm	A-COP (256nm)	+ C-Film of LC(300nm)	COP (0nm)	5

55

(continued)

Internal Protective Film of 2nd Polarizing Plate (Retardation Value)	Retardation Value of VA-Panel	+A-Film (Retardation Value)	+ C-Film (Retardation Value)	Internal Protective Film of 1st Polarizing Plate(Retardation Value)	Minimum Contrast Ratio at Tilt Angle of 70°
TAC (-64nm)		A-COP (250nm)	+C-Film of LC(320nm)	TAC(-64nm)	15
TAC (-128nm)		A-COP (225nm)	+ C-Film of LC(294nm)	TAC (-128nm)	45
PNB (-192nm)		A-COP (200nm)	+ C-Film of LC(278nm)	PNB (-192nm)	130
PNB (-192nm)		A-COP (200nm)	Polystyrene(247nm)	PNB (-192nm)	130
PNB (-220nm)		A-COP (137nm)	+ C-Film of LC(214nm)	PNB (-200nm)	150
PNB (-220nm)		A-COP (187nm)	+C-Film of LC(270nm)	PNB (-200nm)	140
PNB (-220nm)		+ A-Film of Cured LC (180nm)	+ C-Film of LC(270nm)	PNB (-220nm)	150
PNB (-217nm)		+A-Film of Cured LC(200nm)	-	Polystyrene (-50nm)	80
PNB (-212nm)		Polycarbonate(190nm)	+C-Film of LC(270nm)	PNB (-212nm)	160

**[0041]** Referring to the results of Table 1, when the +A-film and the +C-film are disposed according to the structure of FIG. 1 and the retardation values of the films and the internal protective films of the polarizing plates are set as in Table 1, the minimum contrast ratio at a tilt angle of 70° in a dark state is determined to be good upto the range from 130:1 to 150:1 depending on set conditions. Compared to US Patent No. 6,141,075, which uses a -C-plate compensation film and an A-plate compensation film, in which the minimum contrast ratio at a tilt angle of 70° is merely 20:1, the VA-LCD according to the first embodiment of the present invention is confirmed to have excellent contrast properties.

**[0042]** FIG. 2 shows the structure of a VA-LCD according to a second embodiment of the present invention. The structure of this VA-LCD has the following features.

**[0043]** The structure of FIG. 2 has the constituents and configuration sequence, same as the structure of FIG. 1, with the exception that the optic axis 8 of a +A-film 7 disposed between a VA-LCD panel 5 and a +C-film 6 is parallel to the absorption axis 2 of a first polarizing plate 1.

**[0044]** In the present invention, the concept including the structure according to the first embodiment, in which the optic axis 8 of the +A-film 7 is perpendicular to the absorption axis 2 of the first polarizing plate 1, and the structure according to the second embodiment, in which the optic axis 8 of the +A-film 7 is parallel to the absorption axis 2 of the first polarizing plate 1, that is, the concept in which the optic axis of the +A-film is perpendicular to or parallel to the absorption axis of the first polarizing plate, is regarded as the basic structure. In addition, the in-plane retardation value of the +A-film, the thickness retardation value of the +C-film adjacent thereto, and/or the retardation value of the internal protective film of the polarizing plate vary depending on the configuration of the optic axis of the +A-film.

**[0045]** According to the second embodiment, in order to minimize the leakage of light in a dark state, the in-plane retardation value of the +A-film 7 preferably ranges from 130 nm to 300 nm at a wavelength of 550 nm, and the thickness retardation value of the +C-film 6 preferably ranges from 200 nm to 600 nm at a wavelength of 550 nm.

**[0046]** Examples of the internal protective film of the polarizing plate include an unstretched cycloolefin polymer (COP) film having a retardation value close to 0, a triacetate cellulose (TAC) film having a retardation value of 0, a triacetate cellulose film and a polynorbornene (PNB) film having a negative retardation value, etc.

**[0047]** Examples of the +A-film 7 include a stretched cycloolefin polymer film, a stretched polycarbonate film, a horizontally aligned UV curing type liquid crystal film, etc. In addition, examples of the +C-film 6 include a vertically aligned

UV curing type liquid crystal film. The +C-film 6 may be used as the internal protective film of the polarizing plate.

**[0048]** In Table 2 below are summarized the results of simulation of the contrast properties at a tilt angle of 70° performed while varying each of the following conditions: a) the retardation value of the +A-film 7, b) the retardation value of the +C-film 6, and c) the type of internal protective film of the first polarizing plate 1 and the second polarizing plate 3, which are design values for practical retardation films disposed as in FIG. 2.

Table 2

Internal Protective Film of 2nd Polarizing Plate (Retardation Value)	Retardation Value of VA-Panel	+ A-Film (Retardation Value)	+ C-Film (Retardation Value)	Internal Protective Film of 1st Polarizing Plate (Retardation Value)	Minimum Contrast Ratio at Tilt Angle of 70°
COP (0nm)	330nm	A-COP (250nm)	+ C-Film of LC(330nm)	COP (0nm)	4
TAC (-64nm)		A-COP (250)	+ C-Film of LC(320nm)	TAC (-64nm)	10
TAC (-128nm)		A-COP (240nm)	+C-Film of LC(330nm)	TAC (-128nm)	40
PNB (-192nm)		A-COP (210nm)	+C-Film of LC(372nm)	PNB (-192nm)	75
PNB (-300nm)		A-COP (137nm)	+ C-Film of LC(362nm)	PNB (-220nm)	100
PNB (-270nm)		A-COP (160nm)	+ C-Film of LC(365nm)	PNB (-220nm)	120
PNB (-270nm)		Polycarbonate (165nm)	+C-Film of LC(357nm)	PNB (-220nm)	120
PNB (-270nm)		Polycarbonate (165nm)	Polystyrene (324nm)	PNB (-220nm)	140
PNB (-240nm)		+A-Film of Cured LC (185nm)	Polystyrene (334nm)	PNB (-220nm)	120
PNB (-240nm)		+ A-Film of Cured LC (185nm)	-	Polystyrene (-115nm)	125
PNB (-280nm)		+A-Film of Cured LC (180nm)	+C-Film of LC(495nm)	PNB (-350nm)	95

**[0049]** From the results of Table 2, which are similar to those of Table 1 according to the first embodiment, when the +A-film and the +C-film are disposed according to the structure of the second embodiment and the retardation values of the films and the protective films of the polarizing plates are appropriately set, it can be confirmed that the minimum contrast ratio at a tilt angle of 70° in a dark state is good depending on set conditions and that the leakage of light in a dark state is minimized.

**[0050]** FIG. 3 shows the structure of a VA-LCD according to a third embodiment of the present invention, which is different from the structure according to the first embodiment in that a second +A-film 9 is further provided between the second polarizing plate and the VA-panel of the structure of FIG. 1, and the optic axis 10 of the second +A-film 9 is perpendicular to the absorption axis 4 of a second polarizing plate 3 adjacent thereto.

**[0051]** In the structure of FIG. 3, in order to minimize the leakage of light in a dark state, as in the structures according to the first and second embodiments, the first +A-film 7, the second +A-film 9, and the +C-film 6 also have the range of preferred retardation values. According to the third embodiment, the in-plane retardation value of the +A-film 7 preferably ranges from 180 nm to 250 nm at a wavelength of 550 nm, the in-plane retardation value of the second +A-film 9 ranges from 10 nm to 150 nm at a wavelength of 550 nm, and the thickness retardation value of the +C-film 6 preferably ranges

from 200 nm to 600 nm at a wavelength of 550 nm.

**[0052]** Examples of the internal protective film of the polarizing plate include an unstretched cycloolefin polymer (COP) film having a retardation value close to 0, a triacetate cellulose (TAC) film having a retardation value of 0, a triacetate cellulose film and a polynorbornene (PNB) film having a negative retardation value, etc.

**[0053]** Examples of the first +A-film 7 and second +A-film 9 include a stretched cycloolefin polymer film, a stretched polycarbonate (PC) film, a horizontally aligned UV curing type liquid crystal film, etc. In addition, examples of the +C-film 6 include a vertically aligned UV curing type liquid crystal film. The +C-film 6 may be used as the internal protective film of the polarizing plate.

**[0054]** In Table 3 below are summarized the results of simulation of the contrast properties at a tilt angle of 70° performed while varying each of the following conditions: a) the retardation value of the first +A-film 7 and the second +A-film 9, b) the retardation value of the +C-film 6, and c) the type of internal protective film of the first polarizing plate 1 and the second polarizing plate 3, which are design values for practical retardation films disposed as in FIG. 3.

Table 3

Internal Protective Film of 2nd Polarizing Plate (Retardation Value)	2nd +A-Film (Retardation Value)	Retardation Value of VA-Panel	1st +A-Film (Retardation Value)	+ C-Film (Retardation Value)	Internal Protective Film of 1st Polarizing Plate (Retardation Value)	Minimum Contrast Ratio at Tilt Angle of 70°
COP (0nm)	A-COP (113nm)	330nm	A-COP (215nm)	+C-Film of LC(210nm)	COP (0nm)	17
COP (0nm)	A-COP (113nm)		A-COP (215nm)	+C-Film of LC(290nm)	TAC (-64nm)	15
TAC (-64nm)	A-COP (55nm)		A-COP (212nm)	+C-Film of LC(260nm)	TAC (-64nm)	30
TAC (-64nm)	A-COP (55nm)		A-COP (212nm)	+C-Film of LC(400nm)	PNB (-192nm)	30
TAC (-128nm)	A-COP (20nm)		A-COP (206nm)	+ C-Film of LC(285nm)	TAC (-128nm)	100
TAC (-128nm)	A-COP (20nm)		A-COP (206nm)	+ C-Film of LC(535nm)	PNB (-350nm)	110
TAC (-128nm)	A-COP (20nm)		Polycarbonate (208nm)	C-Film of LC(535nm)	PNB (-350nm)	60
TAC (-64nm)	A-COP (55nm)		Polycarbonate (212nm)	Polystyrene (215nm)	TAC (-64nm)	22
A-COP (Rin=55nm, Rth=0nm)	-		COP(215nm)	Polystyrene (245nm)	TAC (-64nm)	16

**[0055]** From the results of Table 3, it can be confirmed that the minimum contrast ratio at a tilt angle of 70° in a dark state is good by appropriately setting the conditions for the retardation values of the +A-film, the +C-film and the internal protective films of the polarizing plates, and that the leakage of light in a dark state is minimized.

**[0056]** FIG. 4 shows the structure of a VA-LCD according to a fourth embodiment of the present invention, which is similar to the structure of FIG. 3, with the exception that the optic axis 8 of a first +A-film 7 is parallel to the absorption axis 2 of a first polarizing plate 1 adjacent thereto, unlike the structure of FIG. 3.

**[0057]** Even in the structure of the fourth embodiment, in order to minimize the leakage of light in a dark state, the first +A-film 7, the second +A-film 9, and the +C-film 6 have the range of preferred retardation values. That is, the in-plane retardation value of the first +A-film 7 preferably ranges from 200 nm to 300 nm at a wavelength of 550 nm, the in-plane retardation value of the second +A-film 9 ranges from 10 nm to 150 nm at a wavelength of 550 nm, and the thickness retardation value of the +C-film 6 preferably ranges from 180 nm to 600 nm at a wavelength of 550 nm.

**[0058]** Examples of the internal protective film of the polarizing plate include an unstretched cycloolefin polymer (COP) film having a retardation value close to 0, a triacetate cellulose (TAC) film having a retardation value of 0, a triacetate

cellulose film and a polynorbornene (PNB) film having a negative retardation value, etc.

**[0059]** Examples of the first +A-film 7 and second +A-film 9 include a stretched cycloolefin polymer film, a stretched polycarbonate (PC) film, a horizontally aligned UV curing type liquid crystal film, etc. In addition, examples of the +C-film 6 include a vertically aligned UV curing type liquid crystal film. The +C-film 6 may be used as the internal protective film of the polarizing plate.

**[0060]** In Table 4 below are summarized the results of simulation of the contrast properties at a tilt angle of 70° performed while varying the following conditions: a) the type of internal protective film of the first polarizing plate 1 and the second polarizing plate 3, b) the retardation value of the +C-film 6, and c) the retardation value of the first +A-film 7 and the second +A-film 9.

Table 4

Internal Protective Film of 2nd Polarizing Plate(Retardation Value)	2nd + A-Film (Retardation Value)	Retardation Value of VA-Panel	1st + A-Film (Retardation Value)	+ C-Film (Retardation Value)	Internal Protective Film of 1st Polarizing Plate (Retardation Value)	Minimum Contrast Ratio at Tilt Angle of 70°
COP (0nm)	A-COP (100nm)	330nm	A-COP (260nm)	Polystyrene (195nm)	COP (0nm)	18
A-COP (-100nm)	-		A-COP (260nm)	Polystyrene (195nm)	COP (0nm)	18
TAC (-64nm)	A-COP (70nm)		A-COP (262nm)	Polystyrene (245nm)	TAC (-64nm)	30
TAC (-128nm)	A-COP (40nm)		A-COP (255nm)	Polystyrene (280nm)	TAC (-128nm)	80
TAC (-128nm)	A-COP (40nm)		A-COP (253nm)	+C-Film of LC(310nm)	TAC (-128nm)	80
TAC (-128nm)	A-COP (26nm)		A-COP (245nm)	+ C-Film of LC(496nm)	PNB (-300nm)	70

**[0061]** In the structure of the fourth embodiment, it can also be confirmed that the minimum contrast ratio at a tilt angle of 70° in a dark state depending on set conditions for the retardation values of the +A-film, the +C-film and the internal protective films of the polarizing plates is superior to conventional contrast ratios, and that the leakage of light in a dark state is minimized.

**[0062]** FIG. 5 shows the structure of a VA-LCD according to a fifth embodiment of the present invention.

**[0063]** The structure of FIG. 5 is characterized in that a second +A-film and a second +C-film are provided between a VA-panel 5 and a second polarizing plate 3 of the structure of FIG. 1, in which the second +C-film is positioned between the second polarizing plate 3 and the second +A-film 9, and the optic axis 10 of the second +A-film 9 is perpendicular to the absorption axis 4 of the second polarizing plate 3.

**[0064]** In the structure of FIG. 5, a first +A-film 7 and a first +C-film 6 are placed between a first polarizing plate 1 and the VA-panel 5, the first +C-film 6 is placed between the first polarizing plate 1 and the first +A-film 7, the first +A-film 7 is disposed adjacent to the VA-panel 5, and the optic axis 8 of the first +A-film 7 is perpendicular to the absorption axis 2 of the first polarizing plate 1, like the structures of FIGS. 1 and 3.

**[0065]** In order to minimize the leakage of light in a dark state from the structure of FIG. 5, the first +A-film 7, the second +A-film 9, the first +C-film 6 and the second +C-film 11 have the range of preferred retardation values. That is, the in-plane retardation value of the first +A-film 7 preferably ranges from 240 nm to 270 nm at a wavelength of 550 nm, and the in-plane retardation value of the second +A-film 9 ranges from 190 nm to 220 nm at a wavelength of 550 nm. Further, the thickness retardation value of the first +C-film 6 and second +C-film 11 preferably ranges from 100 nm to 600 nm at a wavelength of 550 nm.

**[0066]** Examples of the internal protective film of the polarizing plate include an unstretched cycloolefin polymer (COP) film having a retardation value close to 0, a triacetate cellulose (TAC) film having a retardation value of 0, a triacetate cellulose film and a polynorbornene (PNB) film having a negative retardation value, etc.

**[0067]** Examples of the first +A-film 7 and second +A-film 9 include a stretched cycloolefin polymer film, a stretched polycarbonate (PC) film, a horizontally aligned UV curing type liquid crystal film, etc. In addition, examples of the first

## EP 1 859 317 B1

+C-film 6 and second +C-film 11 include a vertically aligned UV curing type liquid crystal film. The first +C-film 6 or second +C-film 11 may be used as the internal protective film of the polarizing plate.

**[0068]** In Table 5 below are summarized the results of simulation of the contrast properties at a tilt angle of 70° performed while varying the following conditions: a) the type of internal protective film of the first polarizing plate 1 and the second polarizing plate 3, b) the retardation value of the first +C-film 6 and the second +C-film 11, and c) the retardation value of the first +A-film 7 and the second +A-film 9.

5

10

15

20

25

30

35

40

45

50

55

5  
10  
15  
20  
25  
30  
35  
40  
45  
50  
55

Table 5

Internal Protective Film of 2nd Polarizing Plate (Retardation Value)	2nd + C-Film (Retardation Value)	2nd + A-Film (Retardation Value)	Retardation Value of VA-Panel	1st + A-Film (Retardation Value)	1st + C-Film (Retardation Value)	Internal Protective Film of 1st Polarizing Plate (Retardation Value)	Minimum Contrast Ratio at Tilt Angle of 70°
COP (0nm)	+C-Film of LC (140nm)	+ A-Film of Cured LC(200nm)	330nm	+ A-Film of Cured LC(250nm)	+C-Film of LC (140nm)	COP (0nm)	27
TAC (-64nm)	+C-Film of LC (206nm)	+ A-Film of Cured LC(200nm)		+A-Film of Cured LC(250nm)	+C-Film of LC (206nm)	TAC (-64nm)	30
TAC (-64nm)	+ C-Film of LC (210nm)	A-COP (200nm)	330nm	A-COP (250nm)	+ C-Film of LC (210nm)	TAC (-64nm)	90
TAC (-128nm)	+ C-Film of LC (282nm)	A-COP (200nm)		A-COP (250nm)	+ C-Film of LC (282nm)	TAC (-128nm)	110
PNB (-250nm)	+ C-Film of LC (418nm)	A-COP (200nm)		A-COP (250nm)	+C-Film of LC (418nm)	PNB (-250nm)	120

**[0069]** The structure of a VA-LCD according to a sixth embodiment of the present invention is characterized as follows.

**[0070]** As shown in FIG. 6, a first +A-film 7 and a first +C-film 6 are placed between a first polarizing plate 1 and a VA-panel 5, the first +C-film 6 is placed between the first polarizing plate 1 and the first +A-film 7, the first +A-film 7 is disposed adjacent to the VA-panel 5, and the optic axis 8 of the first +A-film 7 is parallel to the absorption axis 2 of the first polarizing plate 1.

**[0071]** Further, a second +A-film 9 and a second +C-film 11 are placed between a second polarizing plate 3 and the VA-panel 5, the second +C-film 11 is placed between the second polarizing plate 3 and the second +A-film 9, the second +A-film 9 is disposed adjacent to the VA-panel 5, and the optic axis 10 of the second +A-film 9 is parallel to the absorption axis 4 of the second polarizing plate 3.

**[0072]** In the structure of FIG. 6, the in-plane retardation value of the first +A-film 7 and the second +A-film 9 ranges from 240 nm to 270 nm at a wavelength of 550 nm, and the thickness retardation value of the first +C-film 6 and the second +C-film 11 preferably ranges from 100 nm to 600 nm at a wavelength of 550 nm.

**[0073]** Examples of the internal protective film of the polarizing plate include an unstretched cycloolefin polymer (COP) film having a retardation value close to 0, a triacetate cellulose (TAC) film having a retardation value of 0, a triacetate cellulose film and a polynorbornene (PNB) film having a negative retardation value, etc.

**[0074]** Examples of the first +A-film 7 and the second +A-film 9 include a stretched cycloolefin polymer film, a stretched polycarbonate (PC) film, a horizontally aligned UV curing type liquid crystal film, etc. In addition, examples of the first +C-film 6 include a vertically aligned UV curing type liquid crystal film. The first +C-film 6 or the second +C-film 11 may be used as the internal protective film of the first or second polarizing plate 1, 3, respectively.

**[0075]** In Table 6 below are summarized the results of simulation of the contrast properties at a tilt angle of 70° performed while varying the following conditions: a) the type of internal protective film of the first polarizing plate 1 and the second polarizing plate 3, b) the retardation value of the first +C-film 6 and the second +C-film 11, and c) the retardation value of the first +A-film 7 and the second +A-film 9.

Table 6

Internal Protective Film of 2nd Polarizing Plate(Retardation Value)	2nd + C-Film (Retardation Value)	2nd + A-Film (Retardation Value)	Retardation Value of VA-Panel	1st + A-Film (Retardation Value)	1st + C-Film (Retardation Value)	Internal Protective Film of 1st Polarizing Plate (Retardation Value)	Minimum Contrast Ratio at Tilt Angle of 70°
Polystyrene ne(-175nm)	-	+A-Film of Cured LC(260nm)	330nm	+ A-Film of Cured LC(260nm)	-	Polystyrene (-175nm)	24
TAC (-64nm)	+ C-Film or LC (244nm)	A-COP (257nm)		A-COP (257nm)	+ C-Film of LC (244nm)	TAC (-64nm)	23
TAC (-128nm)	+ C-Film of LC (315nm)	A-COP (257nm)		A-COP (257nm)	+ C-Film of LC (315nm)	TAC (-128nm)	22
PNB (-250nm)	+ C-Film ofLC (450nm)	A-COP (257nm)		A-COP (257nm)	+ C-Film ofLC (450nm)	PNB (-250nm)	20

**[0076]** The structure of a VA-LCD according to a seventh embodiment of the present invention is characterized as follows.

**[0077]** As shown in FIG. 7, a first +A-film 7 and a first +C-film 6 are placed between a first polarizing plate 1 and a VA-panel 5, the first +C-film 6 is placed between the first polarizing plate 1 and the first +A-film 7, the first +A-film 7 is disposed adjacent to the VA-panel 5, and the optic axis 8 of the first +A-film 7 is parallel to the absorption axis 2 of the first polarizing plate 1.

**[0078]** Further, a second +A-film 9 and a second +C-film 11 are placed between a second polarizing plate 3 and the VA-panel 5, the second +A-film 9 is disposed adjacent to the VA-panel 5, the second +C-film 11 is placed between the second polarizing plate 3 and the second +A-film 9, and the optic axis 10 of the second +A-film 9 is perpendicular to the absorption axis 4 of the second polarizing plate 3.

**[0079]** In order to minimize the leakage of light in a dark state from the structure of FIG. 7, the first +A-film 7, the second +A-film 9, the first +C-film 6, and the second +C-film 11 have the range of preferred retardation values. That is, the in-plane retardation value of the first +A-film 7 preferably ranges from 240 nm to 270 nm at a wavelength of 550 nm and the in-plane retardation value of the second +A-film 9 preferably ranges from 190 nm to 220 nm at a wavelength of 550 nm. Further, the thickness retardation value of the first +C-film 6 and the second +C-film 11 preferably ranges from 100 nm to 600 nm at a wavelength of 550 nm.

**[0080]** Examples of the internal protective film of the polarizing plate include an unstretched cycloolefin polymer (COP) film having a retardation value close to 0, a triacetate cellulose (TAC) film having a retardation value of 0, a triacetate cellulose film and a polynorbornene (PNB) film having a negative retardation value, etc.

**[0081]** Examples of the first +A-film 7 and the second +A-film 9 include a stretched cycloolefin polymer film, a stretched polycarbonate film, a horizontally aligned UV curing type liquid crystal film, etc. In addition, examples of the first +C-film 6 and the second +C-film 11 include a vertically aligned UV curing type liquid crystal film. The +C-film 6 may be used as the internal protective film of the polarizing plate. The first +C-film 6 or the second +C-film 11 may be used as the internal protective film of the first or second polarizing plate 1, 3, respectively.

**[0082]** In Table 7 below are summarized the results of simulation of the contrast properties at a tilt angle of 70° performed while varying the following conditions: a) the type of internal protective film of the first polarizing plate 1 and the second polarizing plate 3, b) the retardation value of the first +C-film 6 and the second +C-film 11, and c) the retardation value of the first +A-film 7 and the second +A-film 9.

Table 7

Internal Protective Film of 2nd Polarizing Plate(Retardation Value)	2nd + C-Film (Retardation Value)	2nd + A-Film (Retardation Value)	Retardation Value of VA-Panel	1st + A-Film (Retardation Value)	1st + C-Film (Retardation Value)	Internal Protective Film of 1st Polarizing Plate(Retardation Value)	Minimum Contrast Ratio at Tilt Angle of 70°
Polystyrene (-175nm)	-	A-COP (200nm)	330nm	A-COP (267nm)	-	Polystyrene (-166nm)	100
COP (0nm)	+ C-Film of LC (132nm)	A-COP (200nm)		+ C-Film of LC (175nm)	COP (0nm)	110	
TAC (-64nm)	+ C-Film of LC (204nm)	A-COP (200nm)		+C-Film of LC (250nm)	TAC (-64nm)	100	
TAC (-64nm)	+C-Film of LC (278nm)	A-COP (200nm)		+C-Film of LC (320nm)	TAC (-128nm)	83	

5

10

15

20

25

30

35

40

45

50

55

**[0083]** A better understanding of the present invention may be obtained through the following examples which are set forth to illustrate, but are not to be construed as the limit of the present invention.

[Example 1]

**[0084]** The VA-LCD of FIG. 1 according to the first embodiment of the present invention was fabricated.

**[0085]** In particular, a VA-LCD panel 5 filled with liquid crystals having a cell gap of 3.35  $\mu\text{m}$ , a pre-tilt angle of 89°, dielectric anisotropy ( $\Delta\epsilon$ ) of liquid crystals of -4.9, and birefringence ( $\Delta n$ ) of 0.098 was used. The VA-panel 5 had a thickness retardation value of 328 nm at a wavelength of 550 nm.

**[0086]** As a +C-film 6, a vertically aligned UV curing type liquid crystal film was used, the thickness retardation value of which was 355 nm at a wavelength of 550 nm. As a +A-film 7, a stretched cycloolefin polymer film was used, and the in-plane retardation value of this film was 240 nm at a wavelength of 550 nm.

**[0087]** As the internal protective film of a first polarizing plate 1 and a second polarizing plate 3, a 80 $\mu\text{m}$  thick TAC was used, the thickness retardation value of which was -65 nm at a wavelength of 550 nm.

**[0088]** When white light was used, a graph showing contrast at tilt angles from 0 to 80° with respect to the entire radius angle is shown in FIG. 8.

[Example 2]

**[0089]** The VA-LCD of FIG. 2 according to the second embodiment of the present invention was fabricated.

**[0090]** In particular, a VA-LCD panel 5 filled with liquid crystals having a cell gap of 3.35  $\mu\text{m}$ , a pre-tilt angle of 89°, dielectric anisotropy ( $\Delta\epsilon$ ) of liquid crystals of -4.9, and birefringence ( $\Delta n$ ) of 0.098 was used. The VA-panel 5 had a thickness retardation value of 328 nm at a wavelength of 550 nm.

**[0091]** As a +C-film 6, a vertically aligned UV curing type liquid crystal film was used, the thickness retardation value of which was 355 nm at a wavelength of 550 nm. As a +A-film 7, a stretched cycloolefin polymer film was used, the in-plane retardation value of which was 240 nm at a wavelength of 550 nm.

**[0092]** As the internal protective film of a first polarizing plate 1 and a second polarizing plate 3, a 160 $\mu\text{m}$  thick TAC was used, the thickness retardation value of which was -130 nm at a wavelength of 550 nm.

**[0093]** when white light was used, a graph showing contrast at tilt angles from 0 to 80° with respect to the entire radius angle is shown in FIG. 9.

[Example 3]

**[0094]** The VA-LCD of FIG. 3 according to the third embodiment of the present invention was fabricated.

**[0095]** In particular, a VA-LCD panel 5 filled with liquid crystals having a cell gap of 3.35  $\mu\text{m}$ , a pre-tilt angle of 89°, dielectric anisotropy ( $\Delta\epsilon$ ) of liquid crystals of -4.9, and birefringence ( $\Delta n$ ) of 0.098 was used. The VA-panel 5 had a thickness retardation value of 328 nm at a wavelength of 550 nm.

**[0096]** As a +C-film 6, a vertically aligned UV curing type liquid crystal film was used, the thickness retardation value of which was 272 nm at a wavelength of 550 nm. As a first +A-film 7, a stretched cycloolefin polymer film was used, the in-plane retardation value of which was 212 nm. As a second +A-film 9, a stretched cycloolefin polymer film was used, the in-plane retardation value of which was 55 nm at a wavelength of 550 nm.

**[0097]** As the internal protective film of a first polarizing plate 1 and a second polarizing plate 3, a 80 $\mu\text{m}$  thick TAC was used, the thickness retardation value of which was -65 nm at a wavelength of 550 nm.

**[0098]** When white light was used, a graph showing contrast at tilt angles from 0 to 80° with respect to the entire radius angle is shown in FIG. 10.

[Example 4]

**[0099]** The VA-LCD of FIG. 4 according to the fourth embodiment of the present invention was fabricated.

**[0100]** In particular, a VA-LCD panel 5 filled with liquid crystals having a cell gap of 3.35  $\mu\text{m}$ , a pre-tilt angle of 89°, dielectric anisotropy ( $\Delta\epsilon$ ) of liquid crystals of -4.9, and birefringence ( $\Delta n$ ) of 0.098 was used. The VA-panel 5 had a thickness retardation value of 328 nm at a wavelength of 550 nm.

**[0101]** As a +C-film 6, a vertically aligned UV curing type liquid crystal film was used, the thickness retardation value of which was 280 nm at a wavelength of 550 nm. As a first +A-film 7, a stretched cycloolefin polymer film was used, the in-plane retardation value of which was 268 nm. As a second +A-film 9, a stretched cycloolefin polymer film was used, the in-plane retardation value of which was 70 nm at a wavelength of 550 nm.

**[0102]** As the internal protective film of a first polarizing plate 1 and a second polarizing plate 3, a 80 $\mu\text{m}$  thick TAC was used, the thickness retardation value of which was -65 nm at a wavelength of 550 nm.

**[0103]** When white light was used, a graph showing contrast at tilt angles from 0 to 80° with respect to the entire radius angle is shown in FIG. 11.

[Example 5]

**[0104]** The VA-LCD of FIG. 5 according to the fifth embodiment of the present invention was fabricated.

**[0105]** In particular, a VA-LCD panel 5 filled with liquid crystals having a cell gap of 3.35 μm, a pre-tilt angle of 89°, dielectric anisotropy ( $\Delta\epsilon$ ) of liquid crystals of -4.9, and birefringence ( $\Delta n$ ) of 0.098 was used. The VA-panel 5 had a thickness retardation value of 328 nm at a wavelength of 550 nm.

**[0106]** As a first +C-film 6, a vertically aligned UV curing type liquid crystal film was used, the thickness retardation value of which was 210 nm at a wavelength of 550 nm. As a second +C-film 11, a vertically aligned UV curing type liquid crystal film was used, the thickness retardation value of which was 210 nm at a wavelength of 550 nm.

**[0107]** As a first +A-film 7, a stretched cycloolefin polymer film was used, the in-plane retardation value of which was 250 nm at a wavelength of 550 nm. As a second +A-film 9, a stretched cycloolefin polymer film was used, the in-plane retardation value of which was 200 nm at a wavelength of 550 nm.

**[0108]** As the internal protective film of a first Polarizing plate 1 and a second polarizing plate 3, a 80μm thick TAC was used, the thickness retardation value of which was -65 nm at a wavelength of 550 nm.

**[0109]** When white light was used, a graph showing contrast at tilt angles from 0 to 80° with respect to the entire radius angle is shown in FIG. 12.

[Example 6]

**[0110]** The VA-LCD of FIG. 6 according to the sixth embodiment of the present invention was fabricated.

**[0111]** In particular, a VA-LCD panel 5 filled with liquid crystals having a cell gap of 3.35 μm, a pre-tilt angle of 89°, dielectric anisotropy ( $\Delta\epsilon$ ) of liquid crystals of -4.9, and birefringence ( $\Delta n$ ) of 0.098 was used. The VA-panel 5 had a thickness retardation value of 328 nm at a wavelength of 550 nm.

**[0112]** As a first +C-film 6, a vertically aligned UV curing type liquid crystal film was used, the thickness retardation value of which was 244 nm at a wavelength of 550 nm. As a second +C-film 11, a vertically aligned UV curing type liquid crystal film was used, the thickness retardation value of which was 244 nm at a wavelength of 550 nm.

**[0113]** As a first +A-film 7, a stretched cycloolefin polymer film was used, the in-plane retardation value of which was 257 nm at a wavelength of 550 nm. As a second +A-film 9, a stretched cycloolefin polymer film was used, the in-plane retardation value of which was 257 nm at a wavelength of 550 nm.

**[0114]** As the internal protective film of a first polarizing plate 1 and a second polarizing plate 3, a 80μm thick TAC was used, the thickness retardation value of which was -65 nm at a wavelength of 550 nm.

**[0115]** When white light was used, a graph showing contrast at tilt angles from 0 to 80° with respect to the entire radius angle is shown in FIG. 13.

[Example 7]

**[0116]** The VA-LCD of FIG. 7 according to the seventh embodiment of the present invention was fabricated.

**[0117]** In particular, a VA-LCD panel 5 filled with liquid crystals having a cell gap of 3:35 μm, a pre-tilt angle of 89°, dielectric anisotropy ( $\Delta\epsilon$ ) of liquid crystals of -4.9, and birefringence ( $\Delta n$ ) of 0.098 was used. The VA-panel 5 had a thickness retardation value of 328 nm at a wavelength of 550 nm.

**[0118]** As a first +C-film 6, a vertically aligned UV curing type liquid crystal film was used, the thickness retardation value of which was 250 nm at a wavelength of 550 nm. As a second +C-film 11, a vertically aligned UV curing type liquid crystal film was used, the thickness retardation value of which was 204 nm at a wavelength of 550 nm.

**[0119]** As a first +A-film 7, a stretched cycloolefin polymer film was used, the in-plane retardation value of which was 257 nm at a wavelength of 550 nm. As a second +A-film 9, a stretched cycloolefin polymer film was used, the in-plane retardation value of which was 200 nm at a wavelength of 550 nm.

**[0120]** As the internal protective film of a first polarizing plate 1 and a second polarizing plate 3, a 80μm thick TAC was used, the thickness retardation value of which was -65 nm at a wavelength of 550 nm.

**[0121]** When white light was used, a graph showing contrast at tilt angles from 0 to 80° with respect to the entire radius angle is shown in FIG. 14.

**[0122]** Although the preferred embodiments of the present invention have been disclosed for illustrative purposes, those skilled in the art will appreciate that various modifications, additions and substitutions are possible, without departing from the scope of the invention as disclosed in the accompanying claims.

**Industrial Applicability**

[0123] According to the present invention, the contrast of the VA-LCD can be improved at surface-facing angle and tilt angle thereof and color shift depending on the viewing angle in a dark state can be minimized, thus greatly increasing the viewing angle range of the VA-LCD.

**Claims**

1. A vertically aligned liquid crystal display, comprising

a first polarizing plate and a second polarizing plate, having absorption axes perpendicular to each other, and a vertically aligned panel provided therebetween and including vertically aligned liquid crystals having negative dielectric anisotropy, in which one or more first +A films and one or more first +C-films are provided between the first polarizing plate and the vertically aligned panel, the first +C-film is positioned between the first polarizing plate and the first +A-film,

**characterized in that** an optic axis of the first +A-film is perpendicular to or parallel to the absorption axis of the first polarizing plate,

further comprising one or more second +A-films between the second polarizing plate and the vertically aligned panel, in which an optic axis of the second +A-film is perpendicular to the absorption axis of the second polarizing plate,

wherein the first +A-film has an in-plane retardation value ranging from 180 nm to 250 nm at a wavelength of 550 nm, the first +C-film has a thickness retardation value ranging from 200 nm to 600 nm at a wavelength of 550 nm, and the second +A-film has an in-plane retardation value ranging from 10 nm to 150 nm at a wavelength of 550 nm when the optic axis of the first +A-film is perpendicular to the absorption axis of the first polarizing plate, or

wherein the first +A-film has an in-plane retardation value ranging from 200 nm to 300 nm at a wavelength of 550 nm, the first +C-film has a thickness retardation value ranging from 180 nm to 600 nm at a wavelength of 550 nm, and the second +A-film has an in-plane retardation value ranging from 10 nm to 150 nm at a wavelength of 550 nm when the optic axis of the first +A-film is parallel to the absorption axis of the first polarizing plate.

2. The vertically aligned liquid crystal display according to claim 1, wherein the +A-film comprises at least one selected from among a stretched cycloolefin polymer film, a stretched polycarbonate film, and a horizontally aligned UV cured-type liquid crystal film.

3. The vertically aligned liquid crystal display according to claim 1, wherein the +C-film comprises a vertically aligned UV cured-type liquid crystal film.

4. The vertically aligned liquid crystal display according to claim 1, wherein the first polarizing plate and the second polarizing plate have an internal protective film having a thickness retardation value of 0 or a negative thickness retardation value.

5. The vertically aligned liquid crystal display according to claim 4, wherein the internal protective film comprises at least one selected from among an unstretched cycloolefin polymer film, a triacetate cellulose film, and a polynorbornene film.

6. The vertically aligned liquid crystal display according to claim 1, wherein the first +A-film and/or the second +A-film function as the internal protective film of the first polarizing plate and/or the second polarizing plate, respectively.

7. The vertically aligned liquid crystal display according to claim 1, wherein the first +C-film functions as the internal protective film of the first polarizing plate.

8. The vertically aligned liquid crystal display according to claim 1, which uses a multidomain vertically aligned mode or a vertically aligned mode using a chiral additive, in which the vertically aligned panel comprises a liquid crystal cell having a cell gap of 3-8  $\mu\text{m}$ .

## Patentansprüche

### 1. Vertikal ausgerichtete Flüssigkristallanzeige, umfassend

5 eine erste polarisierende Platte und eine zweite polarisierende Platte mit Absorptionsachsen, die senkrecht zueinander sind, und ein vertikal ausgerichtetes Paneel, das dazwischen angeordnet ist und vertikal ausge-  
 richtete Flüssigkristalle mit negativer dielektrischer Anisotropie umfasst, worin einer oder mehrere erste +A-  
 Filme und einer oder mehrere erste +C-Filme zwischen der ersten polarisierenden Platte und dem vertikal  
 10 ausgerichtetem Paneel angeordnet sind, wobei der erste +C-Film zwischen der ersten polarisierenden Platte  
 und dem ersten +A-Film positioniert ist,  
**dadurch gekennzeichnet, dass** eine optische Achse des ersten +A-Filmes senkrecht zu oder parallel zu der  
 Absorptionsachse der ersten polarisierenden Platte ist,  
 weiterhin umfassend einen oder mehrere zweite +A-Filme zwischen der zweiten polarisierenden Platte und  
 dem vertikal ausgerichtetem Paneel, worin eine optische Achse des zweiten +A-Filmes senkrecht zu der Ab-  
 15 sorptionsachse der zweiten polarisierenden Platte ist,  
 worin der erste +A-Film einen Retardationswert in der Ebene im Bereich von 180 bis 250 nm bei einer Wellen-  
 länge von 550 nm hat, der erste +C-Film einen Dickenretardationswert im Bereich von 200 bis 600 nm bei einer  
 Wellenlänge von 550 nm hat und der zweite +A-Film einen Retardationswert in der Ebene im Bereich von 10  
 bis 150 nm bei einer Wellenlänge von 550 nm hat, wenn die optische Achse des ersten +A-Filmes senkrecht  
 20 zu der Absorptionsachse der ersten Polarisierungsplatte ist, oder  
 worin der erste +A-Film einen Retardationswert in der Ebene im Bereich von 200 bis 300 nm bei einer Wellen-  
 länge von 550 nm hat, der erste +C-Film einen Dickenretardationswert im Bereich von 180 bis 600 nm bei einer  
 Wellenlänge von 550 nm hat und der zweite +A-Film einen Retardationswert in der Ebene im Bereich von 10  
 bis 150 nm bei einer Wellenlänge von 550 nm hat, wenn die optische Achse des ersten +A-Filmes parallel zu  
 25 der optischen Achse der ersten Polarisierungsplatte ist.

2. Vertikal ausgerichtete Flüssigkristallanzeige nach Anspruch 1, worin der +A-Film zumindest eines enthält, ausge-  
 wählt aus einem gereckten Cycloolefinpolymerfilm, einem gereckten Polycarbonatfilm und einem horizontal ausge-  
 richteten Flüssigkristallfilm vom UV-Härtungstyp.

3. Vertikal ausgerichtete Flüssigkristallanzeige nach Anspruch 1, worin der +C-Film einen vertikal ausgerichteten  
 Flüssigkristallfilm vom UV-Härtungstyp enthält.

4. Vertikal ausgerichtete Flüssigkristallanzeige nach Anspruch 1, worin die erste Polarisierungsplatte und die zweite  
 Polarisierungsplatte einen internen Schutzfilm mit einem Dickenretardationswert von 0 oder einem negativen Di-  
 ckenretardationswert aufweisen.

5. Vertikal ausgerichtete Flüssigkristallanzeige nach Anspruch 4, worin der interne Schutzfilm zumindest eines enthält,  
 ausgewählt aus einem nicht-gerecktem Cycloolefinpolymerfilm, einem Triacetatcellulosefilm und einem Polynorbo-  
 40 nenfilm.

6. Vertikal ausgerichtete Flüssigkristallanzeige nach Anspruch 1, worin der erste +A-Film und/oder der zweite +A-Film  
 als interner Schutzfilm der ersten polarisierenden Platte und/oder der zweiten polarisierenden Platte fungiert.

7. Vertikal ausgerichtete Flüssigkristallanzeige nach Anspruch 1, worin der erste +C-Film als interner Schutzfilm der  
 ersten polarisierenden Platte fungiert.

8. Vertikal ausgerichtete Flüssigkristallanzeige nach Anspruch 1, die einen Multidomänen-vertikal ausgerichteten Mo-  
 dus oder einen vertikal ausgerichteten Modus unter Verwendung eines chiralen Additives verwendet, worin das  
 50 vertikal ausgerichtete Paneel eine Flüssigkristallzelle mit einem Zellabstand von 3-8  $\mu\text{m}$  enthält.

## Revendications

### 1. Écran à cristaux liquides alignés verticalement comprenant :

une première plaque de polarisation et une seconde plaque de polarisation, ayant des axes d'absorption per-  
 pendiculaires entre eux, et un panneau aligné verticalement disposé entre celles-ci et comprenant des cristaux

liquides alignés verticalement ayant une anisotropie diélectrique négative, dans lequel un ou plusieurs films +A et un ou plusieurs films +C sont disposés entre la première plaque de polarisation et le panneau aligné verticalement, le premier film +C est positionné entre la première plaque de polarisation et le premier film +A, **caractérisé en ce qu'un** axe optique du premier film +A est perpendiculaire ou parallèle à l'axe d'absorption de la première plaque de polarisation, comprenant en outre un ou plusieurs deuxièmes films +A entre la seconde plaque de polarisation et le panneau aligné verticalement, dans lequel un axe optique du deuxième film +A est perpendiculaire à l'axe d'absorption de la deuxième plaque de polarisation, dans lequel le premier film +A a une valeur de retard dans le plan allant de 180 nm à 250 nm à une longueur d'onde de 550 nm, le premier film +C a une valeur de retard en épaisseur allant de 200 nm à 600 nm à une longueur d'onde de 550 nm, et le deuxième film +A a une valeur de retard dans le plan allant de 10 nm à 150 nm à une longueur d'onde de 550 nm quand l'axe optique du premier film +A est perpendiculaire à l'axe d'absorption de la première plaque de polarisation, ou dans lequel le premier film +A a une valeur de retard dans le plan allant de 200 nm à 300 nm à une longueur d'onde de 550 nm, le premier film +C a une valeur de retard en épaisseur allant de 180 nm à 600 nm à une longueur d'onde de 550 nm, et le deuxième film +A a une valeur de retard dans le plan allant de 10 nm à 150 nm à une longueur d'onde de 550 nm quand l'axe optique du premier film +A est parallèle à l'axe d'absorption de la première plaque de polarisation.

2. Écran à cristaux liquides alignés verticalement selon la revendication 1, dans lequel le film +A comprend au moins l'un sélectionné parmi un film de polymère de cyclooléfine étiré, un film de polycarbonate étiré et un film de cristaux liquides de type durci aux UV alignés horizontalement.
3. Écran à cristaux liquides alignés verticalement selon la revendication 1, dans lequel le film +C comprend un film de cristaux liquides de type durci aux UV alignés verticalement.
4. Écran à cristaux liquides alignés verticalement selon la revendication 1, dans lequel la première plaque de polarisation et la seconde plaque de polarisation ont un film de protection interne ayant une valeur de retard en épaisseur de 0 ou une valeur de retard en épaisseur négative.
5. Écran à cristaux liquides alignés verticalement selon la revendication 4, dans lequel le film de protection interne comprend au moins l'un sélectionné parmi un film de polymère de cyclooléfine non étiré, un film de triacétate de cellulose et un film de polynorbornène.
6. Écran à cristaux liquides alignés verticalement selon la revendication 1, dans lequel le premier film +A et/ou le deuxième film +A fonctionnent comme le film de protection interne respectivement de la première plaque de polarisation et/ou de la seconde plaque de polarisation.
7. Écran à cristaux liquides alignés verticalement selon la revendication 1, dans lequel le premier film +C fonctionne comme film de protection interne de la première plaque de polarisation.
8. Écran à cristaux liquides alignés verticalement selon la revendication 1, qui utilise un mode aligné verticalement multidomaine ou un mode aligné verticalement utilisant un additif chiral, dans lequel le panneau aligné verticalement comprend une cellule de cristaux liquides ayant un intervalle de cellule de 3 à 8  $\mu\text{m}$ .

[Fig. 1]

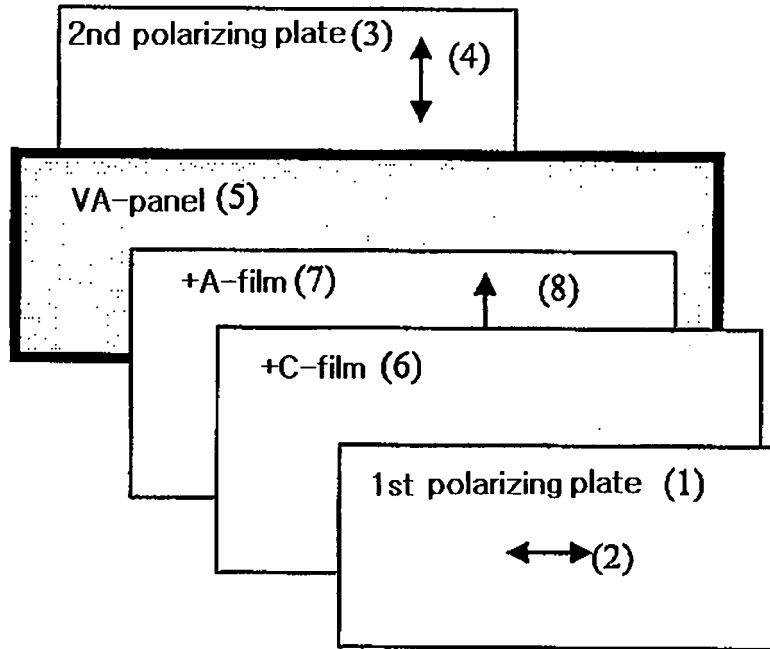

[Fig. 2]

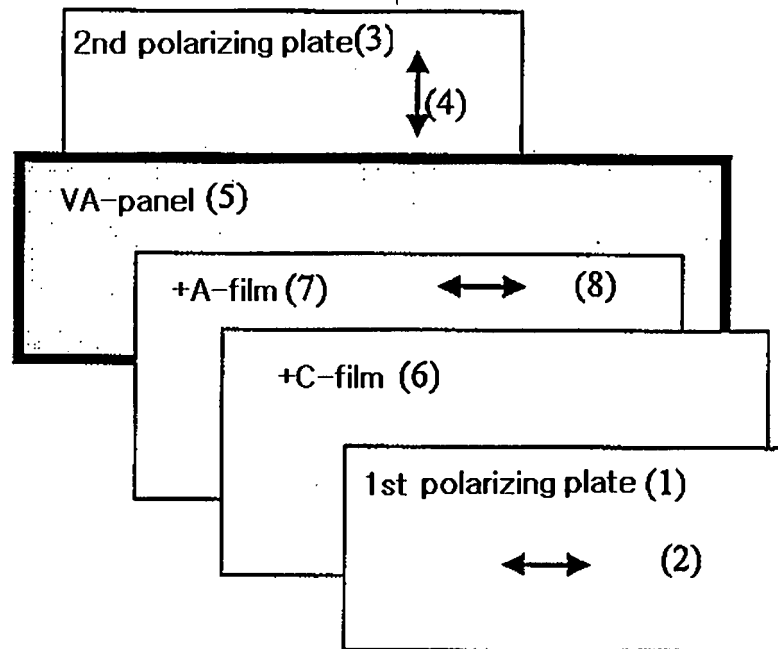

[Fig. 3]

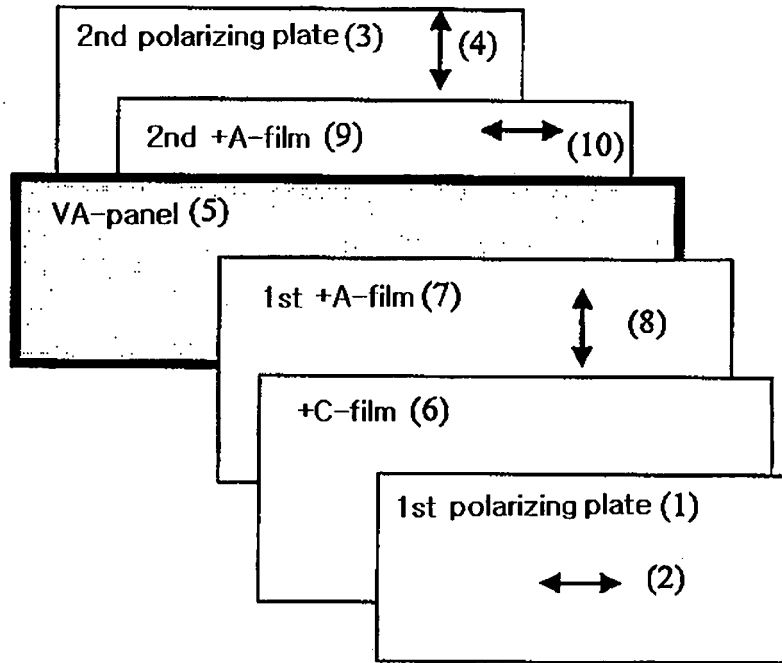

[Fig. 4]

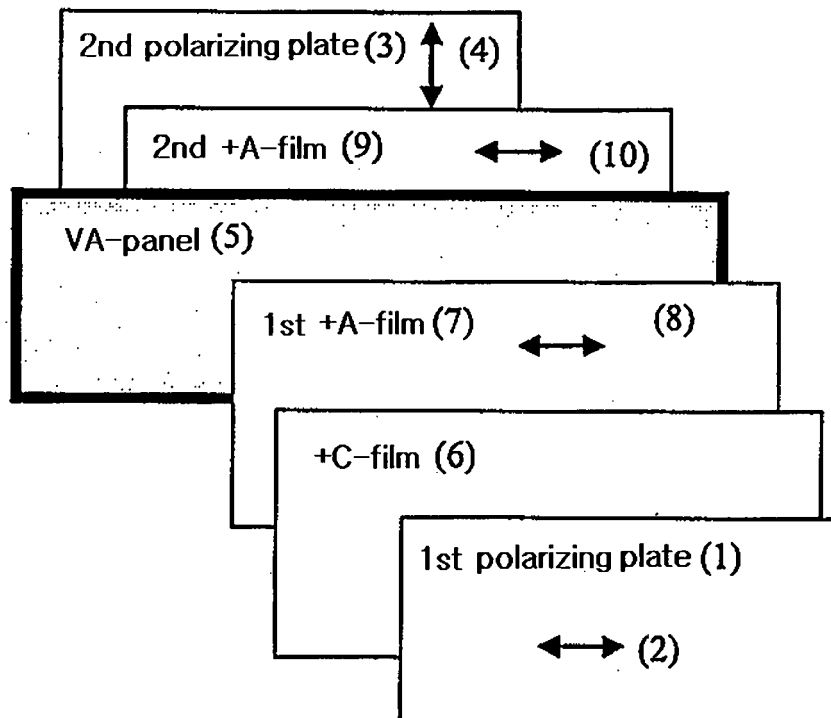

[Fig. 5]

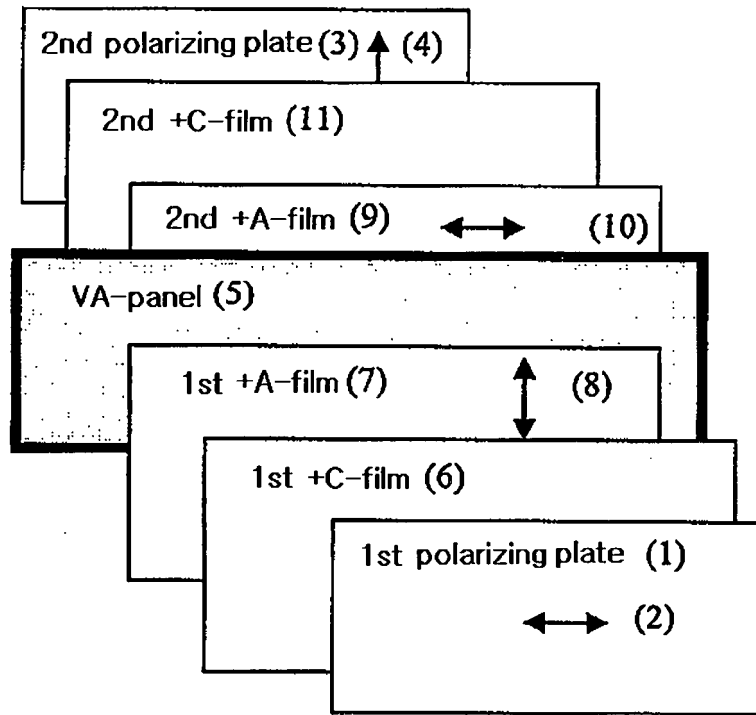

[Fig. 6]

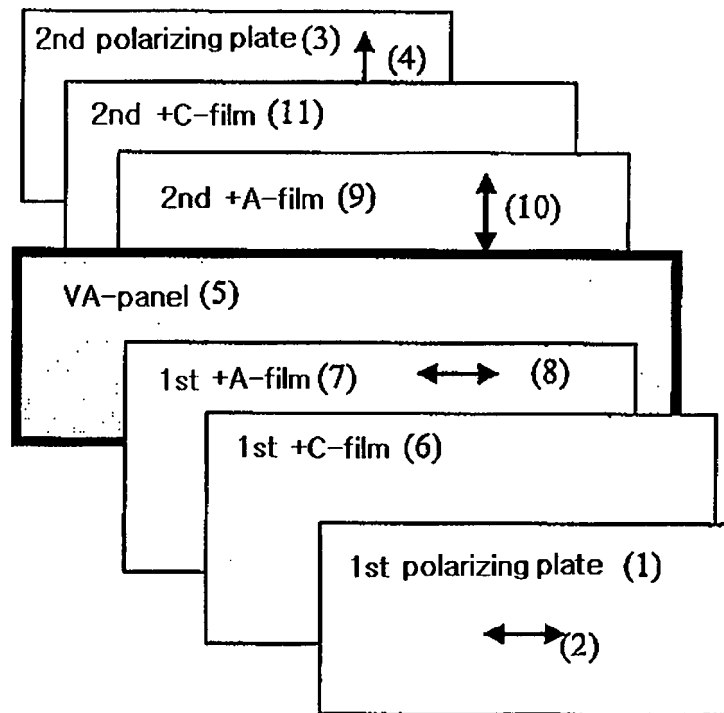

[Fig. 7]

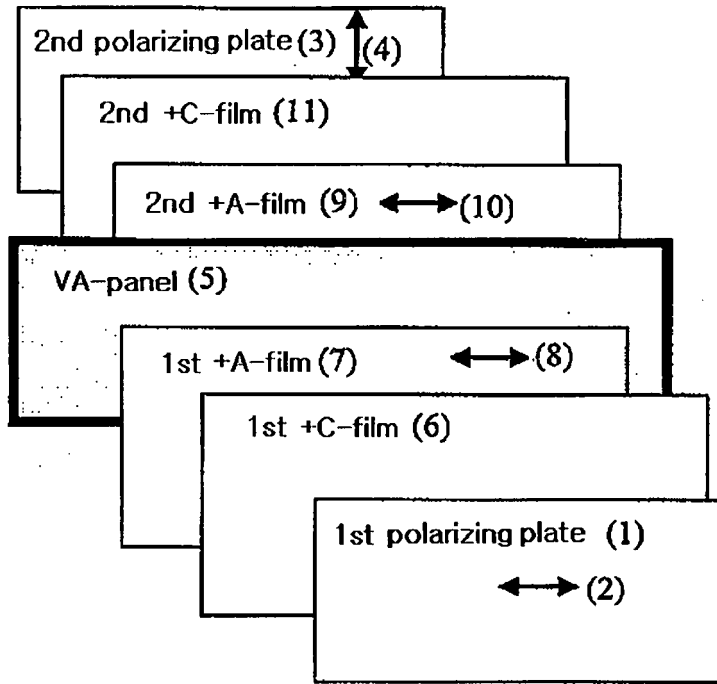

[Fig. 8]

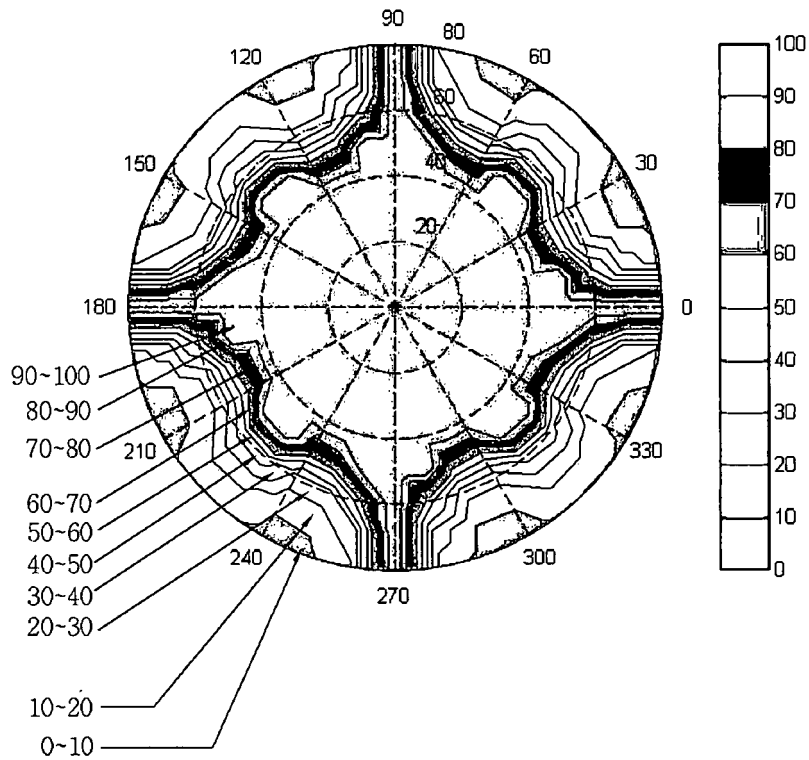

[Fig. 9]

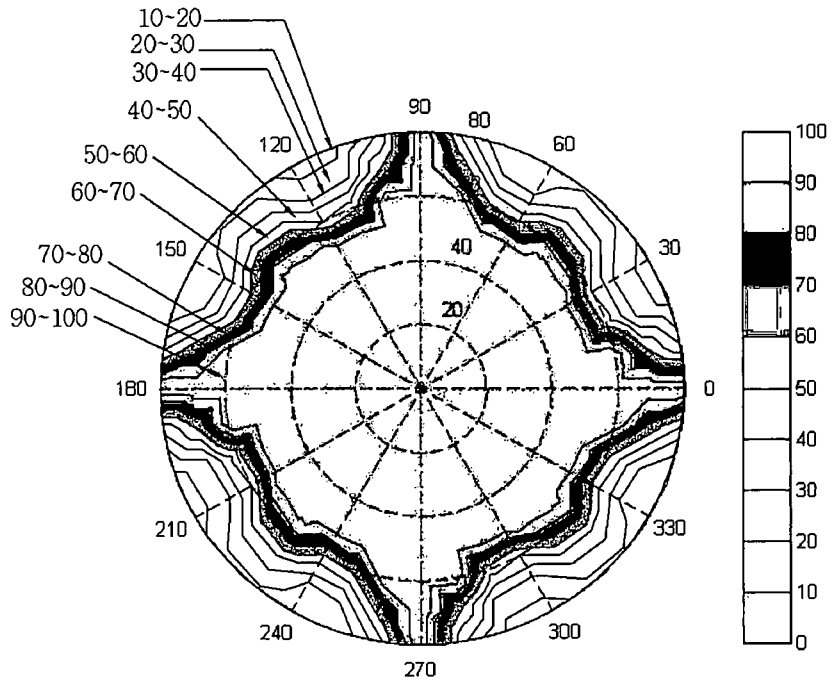

[Fig. 10]

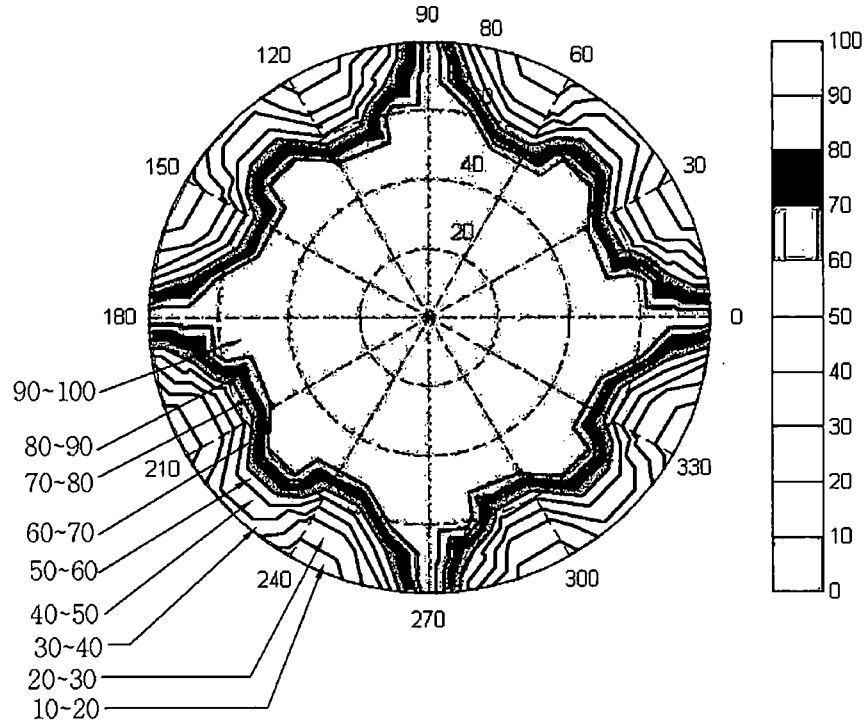

[Fig. 11]

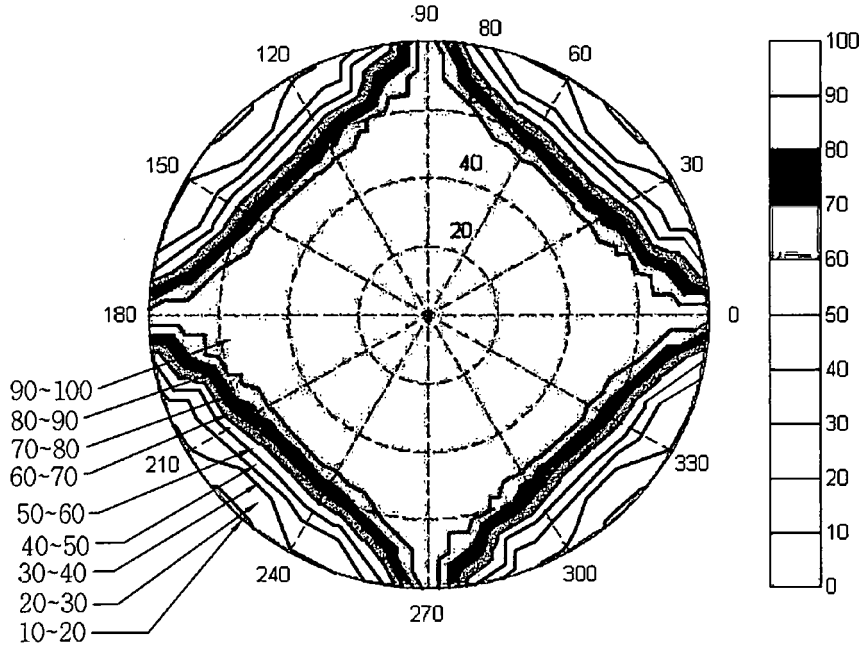

[Fig. 12]

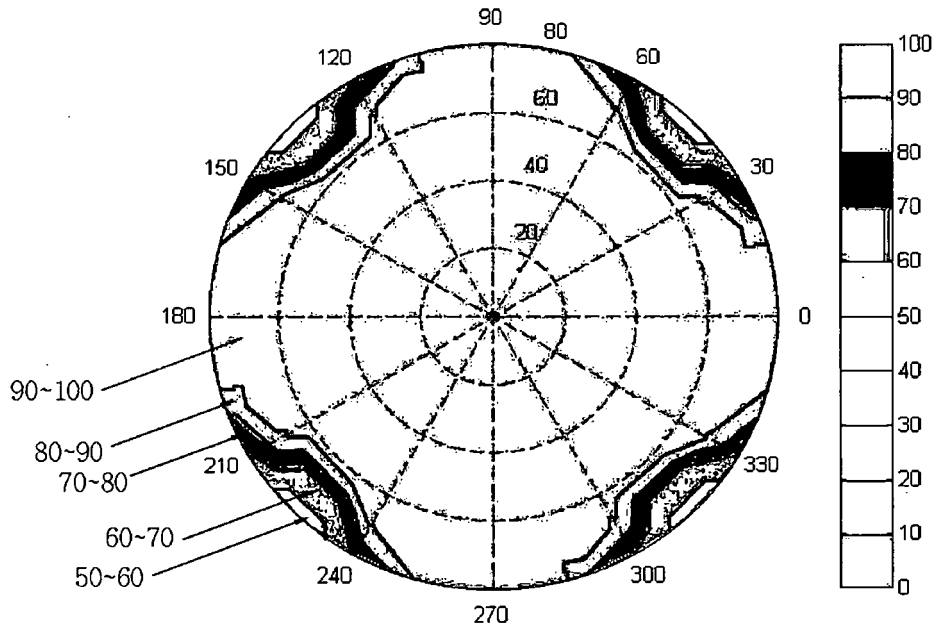

[Fig. 13]

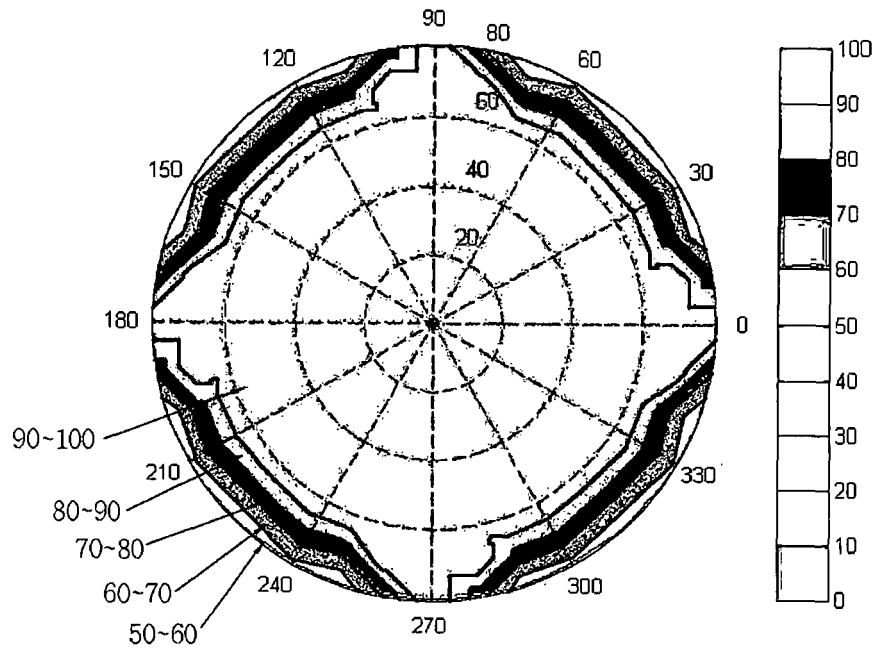

[Fig. 14]

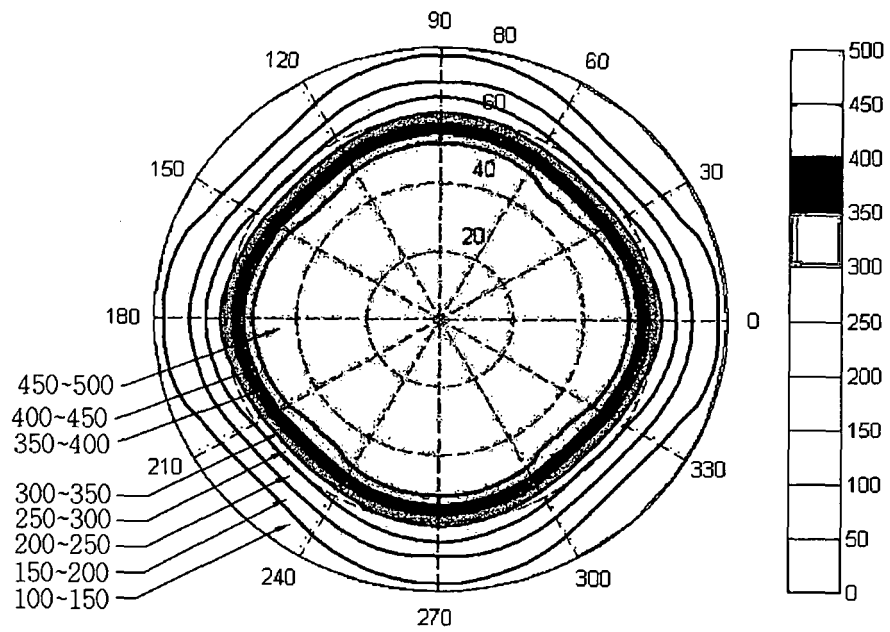

**REFERENCES CITED IN THE DESCRIPTION**

*This list of references cited by the applicant is for the reader's convenience only. It does not form part of the European patent document. Even though great care has been taken in compiling the references, errors or omissions cannot be excluded and the EPO disclaims all liability in this regard.*

**Patent documents cited in the description**

- US 4889412 A [0005]
- US 6141075 A [0006] [0041]
- US 2001048497 A1 [0007]

专利名称(译)	垂直配向的液晶显示器，具有使用+ a-膜和+ c-膜的宽视觉补偿膜		
公开(公告)号	<a href="#">EP1859317B1</a>	公开(公告)日	2016-06-29
申请号	EP2006716303	申请日	2006-03-10
[标]申请(专利权)人(译)	乐金化学股份有限公司		
申请(专利权)人(译)	LG化学有限公司.		
当前申请(专利权)人(译)	LG化学有限公司.		
[标]发明人	JEON BYOUNG KUN 203 LG DORMITORY NEW YEOLLIP BELYAEV SERGEY 6 201 LG CHEM DORMITORY MALIMONENKO NIKOLAY 6 203 LG CHEM DORMITORY CHANG JUN WON 103 LG CHEM NEW YEOLLIP JANG SOO JIN 103 803 SEONGNAE 1 CHA E PYENHAN		
发明人	JEON, BYOUNG-KUN, 203, LG DORMITORY NEW YEOLLIP. BELYAEV, SERGEY, 6-201, LG CHEMISTRY DORMITORY MALIMONENKO, NIKOLAY, 6-203, LG CHEMISTRY DORMITORY CHANG, JUN-WON, 103, LG CHEMISTRY NEW YEOLLIP. JANG, SOO-JIN, 103-803, SEONGNAE 1-CHA, E-PYENHAN		
IPC分类号	G02F1/1335		
CPC分类号	G02F1/1393 G02F1/133528 G02F1/13363 G02F2001/133531 G02F2001/13712 G02F2413/04 G02F2413/11 G02F2413/13		
优先权	1020050020183 2005-03-10 KR		
其他公开文献	EP1859317A4 EP1859317A1		
外部链接	<a href="#">Espacenet</a>		

摘要(译)

本发明提供一种垂直取向的液晶显示器，包括具有彼此垂直的吸收轴的第一偏振片和第二偏振片，以及设置在它们之间的垂直取向的面板，并包括具有负介电各向异性的垂直取向的液晶，其中a + A -film和+ C-薄膜设置在第一偏振片和垂直排列的面板之间，+ C-薄膜位于第一偏振片和+ A-薄膜之间，+ A-薄膜的光轴平行于或垂直于第一偏振片的吸收轴。根据本发明，可以在面对面的角度和倾斜角度下改善垂直取向的液晶显示器的对比度，并且可以在黑暗状态下取决于视角的色移最小化，从而大大增加视角范围。垂直排列的液晶显示器。

Equation 1

$$n_x > n_y = n_z$$