



(11) **EP 1 315 141 B1**

(12) **EUROPEAN PATENT SPECIFICATION**

(45) Date of publication and mention of the grant of the patent:
15.09.2010 Bulletin 2010/37

(51) Int Cl.:
G09G 3/36^(2006.01)

(21) Application number: **02257343.0**

(22) Date of filing: **23.10.2002**

(54) **Method for improving gradation of image, and image display apparatus for performing the method**

Verfahren zur Gradationsverbesserung eines Bilds, und Bildanzeigegerät zur Durchführung des Verfahrens

Méthode pour améliorer la gradation d'image, et dispositif d'affichage d'image pour la mise en oeuvre de cette méthode

(84) Designated Contracting States:
DE FR GB

(30) Priority: **31.10.2001 KR 2001067625**

(43) Date of publication of application:
28.05.2003 Bulletin 2003/22

(73) Proprietors:
• **SAMSUNG ELECTRONICS CO., LTD.**
Suwon City, Kyungki-do 441-373 (KR)
• **Samsung Electro-Mechanics Co. Ltd.**
Suwon-city,
Kyungki-do (KR)

(72) Inventors:
• **Lee, Seong-deok**
Kiheung-eub,
Yongin-city,
Kyungki-do (KR)
• **Kim, Chang-yeong,**
502-1305 Jinsan Maeul Samsung
Yongin-city,
Kyung-do (KR)

(74) Representative: **Greene, Simon Kenneth**
Elkington and Fife LLP
Prospect House
8 Pembroke Road
Sevenoaks
Kent TN13 1XR (GB)

(56) References cited:
EP-A- 0 313 331 EP-A- 0 425 210
WO-A-99/26224 JP-A- 8 227 283
US-A- 4 775 891 US-A- 4 921 334
US-A- 5 250 937 US-A- 5 953 002
US-B1- 6 177 915 US-B1- 6 297 791

• **HIROYUKI MANO: "Multicolor Display Control Method for TFT-LCD" SID INTERNATIONAL SYMPOSIUM DIGEST OF TECHNICAL PAPERS, vol. 22, 10 May 1991 (1991-05-10), pages 547-550, XP002300925 US, PLAYA DEL REY**

EP 1 315 141 B1

Note: Within nine months of the publication of the mention of the grant of the European patent in the European Patent Bulletin, any person may give notice to the European Patent Office of opposition to that patent, in accordance with the Implementing Regulations. Notice of opposition shall not be deemed to have been filed until the opposition fee has been paid. (Art. 99(1) European Patent Convention).

Description

[0001] The present invention relates to an image display apparatus such as a monitor or a television, and more particularly, to a method of improving the gradation of an image and an image display apparatus for performing the method.

[0002] The gradation of an image in the image display apparatus is one of the factors that determine the quality of the image. Unlike a cathode-ray tube (CRT) adopting an electron gun, the performance of a general liquid crystal display (LCD) or liquid-crystal-on-silicon (LCoS) display, which uses liquid crystal, may abruptly change according to the physical characteristics of the crystal used or a method of driving the liquid crystal. Here, the performance is related to the factor with which is transmitted to or reflected from a liquid crystal display panel according to liquid crystal driving voltage. As a result, a general LCD is not capable of appropriately displaying an image having more than a predetermined number of gradations, e.g., 8-bit (2^8) gradations, on each of R, G, and B channels (here R, G, and B denote 'red', 'green' and 'blue, respectively). Even if the 8-bit gradations are all displayed, an irregular difference in the luminance levels of the gradations cannot be removed. Therefore, in a general LCD, when the number of gradations is insufficient or a difference between luminance levels among gradations of the image is irregular, rough gradation borders are prone to occur at an image of a face at which gradations change gradually.

[0003] Hereinafter, conventional methods of improving the gradation of an image will be described.

[0004] First, when the number of gradations displayed is insufficient, the number of insufficient gradations is increased spatially or using time division. In particular, a half-toning method is commonly used to increase the number of gradation spatially. The half-toning method is subdivided into a dithering method of displaying medium gradations using pixels of predetermined area, e.g., 3×3 , and an error diffusion method of comparing an input value of each pixel with values capable of being output and then diffusing a difference between an input value and the output value, i.e., an error value, to neighboring pixels. Here, one of dithering methods is disclosed in US Patent No. 3,937,878 entitled "Animated Dithered Display Systems". In the disclosed dithering method, gradations are displayed with an area mask, and thus, regions of an image having high frequency components are difficult to be displayed, i.e. the resolution of an image may deteriorate. One of error diffusion methods is disclosed in US Patent No. 5,162,925 entitled "Color Image Processor Capable of Performing Masking Using a Reduced Number of Bits". The disclosed error diffusion method overcomes deterioration of the resolution of an image caused by the dithering method, but additionally requires a frame memory of predetermined size to calculate diffused errors, thereby making the structure of a system complex and voluminous. Further, the disclosed error diffusion method generates peculiar patterns at the edge of an image or a color-flattened region.

[0005] A method of controlling frame-rate is a typical method of increasing the number of insufficient gradations using time division. In this method, a unit image frame is divided into sub-frames having different periods of emitting light, e.g., eight sub-frames, on a time axis, and then, these sub-frames are combined to display the gradations of an image. This method is capable of preventing the generation of peculiar patterns when increasing the number of gradation spatially, but may deteriorate the luminance efficiency and cause false contour problems.

[0006] Meanwhile, there is another conventional method of improving the gradation of an image, disclosed in US Patent No. 4,921,334 entitled "Matrix Liquid Crystal Display with Extended Gray Scale". The disclosed method produces new medium gradations by switching neighboring liquid crystal driving voltages. However, this method is disadvantageous in that the number of gradations cannot be increased more than two times.

[0007] There is also a conventional spatial-temporal dithering method of improving the gradation of an image, disclosed in *Three-Five systems* (SID 2000 Seminar lecture notes, volume 1, M-13). This method combines a spatial dithering method using a 2×2 pixel mask, and a temporal dithering method using two different voltage levels adjacent to two sub-fields, and produces three additional gradations. This method is advantageous in that a lot of new gradations can be produced, but the resolution of an output image may deteriorate due to the use of a spatial dithering method. Also, this method generates the aforementioned peculiar patterns at the edge of an image or color-flattened region, and further requires additional circuits to perform this method.

[0008] In the event that a difference between the luminance levels of gradations is irregular, it is difficult to make the irregular difference regular by the above-mentioned conventional methods of improving the gradation of an image. As a result, the number of the gradations may decrease more and more.

[0009] US 5,953,002 describes a way of displaying multiple gradations on a liquid crystal display by applying multiple voltage levels to a pixel.

[0010] According to the invention there is provided a method of improving gradations of an image carried out by a liquid crystal display according to claim 1.

[0011] The present invention thus provides a method which aims to improve the gradation of an image, by which the number of gradations is increased using liquid crystal driving voltages that are produced to have different levels per field, and furthermore, a difference between luminance levels of gradations is made regular.

[0012] In another aspect there is provided a liquid crystal display for performing such a method of improving gradations of an image according to claim 14.

[0013] The features and advantages of the present invention will become more apparent by describing in detail preferred

embodiments thereof with reference to the attached drawings in which:

FIG. 1 is a flow chart for explaining a method of improving the gradation of an image according to a preferred embodiment of the present invention;

FIG. 2 is a block diagram of an image display apparatus, according to a preferred embodiment of the present invention, for performing the method of FIG. 1;

FIG. 3 is a waveform diagram illustrating a liquid crystal driving signal;

FIG. 4 is a graph showing the relationship between a liquid crystal driving voltage and luminance level;

FIG. 5 is a graph exemplarily illustrating the relationship between the number of gradations and new luminance levels in ascending order; and

FIG. 6 is a graph illustrating the relationship between AC components of liquid crystal driving voltage and normalized luminance levels for explaining a method of improving the gradation of an image according to the present invention.

[0014] A method of improving the gradation of an image, and the structure and operation of an image display apparatus capable of performing the method, according to the present invention, will now be described with reference to the accompanying drawings.

[0015] FIG. 1 is a flow chart for explaining a method of improving the gradation of an image according to a preferred embodiment of the present invention. In the method, luminance levels of an image are measured and extracted (steps 10 and 12). Next, new liquid crystal driving voltages are divided into fields (steps 14 and 16). Then, available first luminance levels are selected among the new luminance levels of an image generated by new liquid crystal driving voltages until the gradations of the image are improved (steps 18 through 22).

[0016] FIG. 2 is a block diagram of an image display apparatus, according to the present invention, which carries out the method of FIG. 1. The image display apparatus includes first and second storage units 40 and 42, a liquid crystal driving unit 44, a liquid crystal display panel 46, a liquid crystal driving voltage generator 48, a luminance level calculator 50, and a controller 52.

[0017] In a method for improving the gradation of an image according to a preferred embodiment of the present invention, in step 10, luminance levels of the image displayed on the liquid crystal display panel 46 are measured while changing per frame the liquid crystal driving voltages which are divided into first and second fields that constitute unit frames of the image, and then, a measurement table that shows the relationship between measured luminance levels and the liquid crystal driving voltages, is produced.

[0018] According to this embodiment, the first and second storage units 40 and 42, the liquid crystal driving unit 44, the liquid crystal display panel 46, the liquid crystal driving voltage generator 48 and the controller 52 may perform step 10. Here, the first and second storage units 40 and 42 store in advance the liquid crystal driving voltages that change per frame and have the same level in the two fields of each frame. The liquid crystal driving voltages stored in the first and second storage units 40 and 42 are alternately read out per field in response to first and second control signals C1 and C2 generated by the controller 52. For the read operation of the first and second storage units 40 and 42, it is possible to realize the first and second storage units 40 and 42 as look-up tables or the like. For instance, the first storage unit 40 selectively reads voltage, which corresponds to the size of an image signal input through an input terminal IN1, from liquid crystal driving voltages stored in the first field in response to the first control signal C1 input from the controller 52. Also, the second storage unit 42 selectively reads voltage, which corresponds to the size of an image input through the input terminal IN1, from liquid crystal driving voltages stored in the second field in response to the second control signal C2 input from the controller 52. Here, the controller 52 alternately generates one of the first and second control signals C1 and C2 in the unit of a field, and outputs the same to the first and second storage units 40 and 42.

[0019] FIG. 3 is a waveform diagram illustrating a liquid crystal driving signal. Here, the x-axis and y-axis denote time and the amplitude of the liquid crystal driving signal, respectively.

[0020] The liquid crystal driving unit 44 of FIG. 2 generates a liquid crystal driving signal illustrated in FIG. 3 in response to liquid crystal driving voltage read out selectively by the first or second storage unit 40 or 42, and further outputs the generated liquid crystal driving signal to the liquid crystal display panel 46. Here, when the liquid crystal is driven by alternate current (AC), a unit frame 70 of the liquid crystal driving signal of FIG. 3 is made of first and second fields that are symmetrical with each other with regard to a center voltage Vcom. In other words, as shown in FIG. 3, the liquid crystal driving signal is made of a liquid crystal driving signal for the first field, i.e., Vsig-1, and a liquid crystal driving signal for the second field, i.e., Vsig-2.

[0021] For instance, assuming that the first and second storage units 40 and 42 are look-up tables LUT-1 and LUT-2, the number or index of different sizes an image signal input through the input port IN1 can have is 2^8 , i.e., 256, and the center voltage is 407, liquid crystal driving voltage values of three RGB channels, which are stored in the first and second storage units 40 and 42, are selectively output to the liquid crystal driving unit 44 to correspond to the size of an image signal input through the input terminal IN1, as in the following Table 1:

[Table 1]

Index	LUT-1			LUT-2		
	R	G	B	R	G	B
0	753	753	753	61	61	61
1	752	752	752	62	62	62
2	751	751	751	63	63	63
3	750	750	750	64	64	64
4	749	749	749	65	65	65
...
253	499	499	499	315	315	315
254	498	498	498	316	316	316
255	497	497	497	317	317	317

[0022] At this time, the liquid crystal display panel 46 displays an image via an output terminal OUT with being driven in response to a liquid crystal driving signal input from the liquid crystal driving unit 44. The liquid crystal driving voltage generator 48 measures the luminance levels of images displayed on the liquid crystal display panel 46. For example, the liquid crystal driving voltage generator 48 may be a colorimeter or spectroradiometer.

[0023] After performing step 10, a difference between luminance levels of adjacent gradations from the measured luminance levels is used to extract available second luminance levels (step 12). Luminance levels (y_a and y_b) of adjacent gradations satisfying the following equation are determined as the second luminance levels:

$$\frac{|y_a - y_b|}{y_a} > y_{\text{delta}} \quad \dots (1)$$

wherein y_{delta} corresponds to T/A , where A denotes the number of different luminance levels of the pixel of an image, which is displayed on the liquid crystal display panel 46 and can have, e.g., 2^n , and T denotes an allowable tolerance factor that is within a range of $0 - 2^n$, and is smaller than 1, and is ideally, 1. The more irregular is a difference between luminance levels of gradations, the more T closely approximates 0, thereby reducing the number of the gradations.

[0024] To perform step 12, the liquid crystal driving voltage generator 48 extracts available second luminance levels using a difference between luminance levels of adjacent gradations from the measured luminance levels.

[0025] After step 12, at least one luminance level section whose gradations needs to be improved is selected out of the extracted second luminance levels using equation 1 (step 14).

[0026] FIG. 4 is a graph illustrating the relationship between liquid crystal driving voltage and a luminance level. Here, the x-axis of the graph indicates a difference value between the liquid crystal driving voltage and the reference voltage V_{com} , i.e., AC components of the liquid crystal driving voltage, and the y-axis indicates the luminance level of an image displayed on the liquid crystal display panel 46.

[0027] Referring to FIG. 4, in the even that a change $y_1 - y_0$ in the luminance levels of images displayed on the liquid crystal display panel 46 to a change $v_1 - v_0$ in the liquid crystal driving voltages is very larger, that is, the slope is steep, a luminance level section having the steep slope is determined to be a section whose gradation requires to be improved

[0028] According to this embodiment, step 14 may be performed in the liquid crystal driving voltage generator 48. That is, the liquid crystal driving voltage generator 48 determines a luminance level section among the extracted second luminance levels.

[0029] Meanwhile, step 12 can be omitted in a method for improving gradation of an image according to another embodiment of the present invention. In this case, at least one luminance level section is determined out of the measured luminance levels after step 10 (step 14).

[0030] If the number of gradations expressed is insufficient and thus needs to be increased, step 12 may not be included in the method illustrated in FIG. 1 for improving gradations of an image. However, step 12 must be performed in the method illustrated in FIG. 1 for improving gradations of image if a difference between the luminance levels of gradation must be regular when a difference between the luminance levels of gradations is irregular, and T approximates 0.

[0031] In the method according to a preferred embodiment of the present invention, when determining the luminance level selection the liquid crystal driving voltage generator 48 determines the number of gradations in each luminance level section determined (step 14). If step 12 is included in this method, i.e., there is a need to overcome an irregular difference between luminance levels, a measurement table is compared with a reference table, and measures the number of gradations using the compared result. Here, the reference table is a table where liquid crystal driving voltages and reference luminance levels are written, and is prepared before comparing it with the measurement table.

[0032] After step 14, in each luminance level section determined, new liquid crystal driving voltages are produced to be increased or decreased every the first and second fields centering around the liquid crystal voltage related to the lowest luminance level (step 16). The new liquid crystal driving voltages are obtained with satisfying the following equation according to the present invention:

$$|v_x - v_y| < V_threshold \quad \dots (2)$$

wherein v_y denotes AC components of the new liquid crystal driving voltage with regard to the first field, i.e., a difference between the new liquid crystal driving voltage and a reference voltage V_{com} , which is a DC component. v_x denotes AC components of the new liquid crystal driving voltage with regard to the second field, and $V_threshold$ denotes a voltage critical value allowed in the liquid crystal display panel 46.

[0033] According to the present invention, it is possible to produce a new liquid crystal driving voltage in a limited range, using a measurement table showing the relationship between luminance levels measured and liquid crystal driving voltages, and the condition shown in the following equation (step 16):

$$y_0 < new_y < y_1 \quad \dots (3)$$

wherein y_0 and y_1 denote the highest and lowest luminance levels, respectively in each luminance level section, and new_y denotes a new luminance level.

[0034] Step 16 may be performed by the liquid crystal driving voltage generator 48. In other words, the liquid crystal driving voltage generator 48 produces new liquid crystal driving voltages to be increased or decreased centering around the liquid crystal driving voltage related to the lowest luminance level per first and second fields in each luminance level section determined, satisfying the condition of the equation 2. Otherwise, the liquid crystal driving voltage generator 48 produces new liquid crystal driving voltages in a limited range in accordance with the measurement table, satisfying the condition of the equation 3.

[0035] After step 16, new luminance levels are obtained using the produced new liquid crystal driving voltages (step 18). For performing step 18, according to a preferred embodiment of the present invention, the new luminance levels new_y are obtained by the following equation, using the new liquid crystal driving voltages:

$$new_y = yy * tf_1 + yx * tf_2 \quad \dots (4)$$

wherein $yy = G(v_y)$ and $yx = G(v_x)$. Here, $G(\)$ is a function showing the characteristics of a luminance level yy or yx with regard to a new liquid crystal driving voltage, and may be expressed by the following equation 5 or measured experimentally, and tf_1 and tf_2 denote the first and second field periodic rates, respectively. The first and second field periodic rates indicate values obtained by dividing the periods 72 and 74 of the first and second fields illustrated in FIG. 3 by the frame period 70.

$$G(v_y) = v_y^{1/\gamma} \quad \dots (5)$$

wherein γ is 2.2 - 2.6 in the case of a cathode-ray tube (CRT), but its value varies according to the kind of liquid crystal used in the case of a liquid crystal display (LCD).

[0036] From the following Table 2, it is noted that the luminance level of an image displayed on the liquid crystal display panel 46 in a unit frame at which time a person recognizes the luminance of the image displayed on the liquid crystal panel 46 is $yy/2 + yx/2$, assuming that liquid crystal driving voltage for an arbitrary pixel is expressed with two different

EP 1 315 141 B1

AC components v_x and v_y on the basis of center voltage V_{com} in two fields which constitute a frame, i.e., first and second fields; the first and second period rates are $1/2$; the luminance levels of the first and second fields are expressed with y_y and y_x , respectively.

5

[Table 2]

	Liquid crystal driving voltage	luminance level	periodic rate
first field	$V_{com} + v_y$	y_y	$1/2$
second field	$V_{com} - v_x$	y_x	$1/2$

10

[0037] Therefore, it is concluded that a new luminance level new_y is obtained by driving the liquid crystal display panel 46 with different liquid crystal driving voltages in two consecutive fields.

15

[0038] An image display apparatus according to a preferred embodiment of the present invention may further include the luminance level calculator 50 of FIG. 2 for performing step 18. The luminance level calculator 50 generates new luminance levels from new liquid crystal driving voltages input from the liquid crystal driving voltage generator 48, using the equation 4, and outputs the generated new luminance levels.

20

[0039] In step 18 according to another embodiment of the present invention, the luminance level of an image displayed on the liquid crystal display panel 46, which is driven by a liquid crystal driving signal generated by the liquid crystal driving unit 44 in response to the new liquid crystal driving voltages, can be determined to be a new luminance level. That is, it is possible to obtain a new luminance level without the luminance level calculator 50 shown in FIG. 2. In detail, in an image display apparatus according to the present invention, the first and second storage units 40 and 42 updates liquid crystal driving voltage stored therein with the new liquid crystal driving voltages produced in step 16. Then, the liquid crystal driving unit 44 outputs a liquid crystal driving signal to the liquid crystal display panel 46 in response to the updated new liquid crystal driving voltage. At this time, the liquid crystal display panel 46 displays an image in response to the liquid crystal driving signal, and then, the liquid crystal driving voltage generator 48 measures the luminance level of the image displayed on the liquid crystal display panel 46 as a new luminance level.

25

30

[0040] In detail, for easily understanding steps 16 and 18, assuming that a luminance level section is determined in step 14 to be $y_0 - y_1$, as shown in FIG. 4, a new liquid crystal driving voltage v_y is produced to be increased centering around a liquid crystal driving voltage v_0 related to the lowest luminance level y_0 in a first field of the luminance level section $y_0 - y_1$, and a new liquid crystal driving voltage v_x is produced to be decreased centering around the liquid crystal driving voltage v_0 in the second field of the luminance level section $y_0 - y_1$ as shown in Table 3 (step 16).

[Table 3]

35

number	v_y	v_x	new luminance level
lower base	v_0	v_0	y_0
1	v_1	vm_1	new_y_1
2	v_1	v_0	new_y_2
3	v_2	vm_2	new_y_3
4	v_2	vm_1	new_y_4
5	v_3	vm_3	new_y_5
6	v_3	vm_2	new_y_6
7	v_4	vm_4	new_y_7
8	v_4	vm_3	new_y_8
9	v_5	vm_5	new_y_9
10	v_5	vm_4	new_y_{10}
11	v_6	vm_6	new_y_{11}
12	v_6	vm_5	new_y_{12}
13	v_6	vm_4	new_y_{13}
14	v_7	vm_7	new_y_{14}

50

55

EP 1 315 141 B1

(continued)

number	vy	vx	new luminance level
15	v7	vm6	new_y15
16	v8	vn9	new_y16
17	v8	vm8	new_y17
18	v8	vm7	new_y18
19	v9	vm10	new_y19
20	v9	vm9	new_y20
21	v10	vm10	new_y21
...
N	vP	vmP	new_yN
upper base	v1	v1	y1

[0041] Here, v1 denotes a liquid crystal driving voltage related to the highest luminance level y1, and N denotes the number of gradations in each luminance level section.

[0042] Meanwhile, new liquid crystal driving voltages vy and vx can be produced as shown in the Table 4 when N is 4, and as shown in the Table 5 when N is 2.

[Table 4]

N	lower base	1	2	3	4
vy	v0	vm1	v0	vm2	vm1
vx	v0	v1	v1	v2	v2

[Table 5]

N	lower base	1	2
vy	v0	vm1	v0
vx	v0	v1	v1

[0043] As described above, after step 16, the new luminance level new_yi is obtained using the new liquid crystal driving voltages vy and vx as shown in Table 3, wherein i denotes an index of gradation (step 18).

[0044] FIG. 5 is a graph exemplarily illustrating the relationship between the number of gradations and a new luminance level, aligned in ascending order. Here, the x-axis and y-axis of the graph denote the number of gradations and the new luminance level, respectively.

[0045] For instance, the new liquid crystal driving voltages vy and vx, and a new luminance level new_y illustrated in Table 3 can be as shown in the following table 6 and FIG. 5, assuming that the new luminance level is obtained by the luminance level calculator 50, γ of G() is 3.2, the number N of gradations is 21, the number of different sizes an image signal can have is 2^8 , $v_0 = 149$, $v_1 = 150$, $y_0 = 45.688$, and $y_1 = 46.677$.

[Table 6]

number	vy	Vx	new_y
lower base	149	149	45.69
1	150	148	45.70
2	150	149	46.18
3	151	147	45.72
4	152	148	46.20

(continued)

number	vy	Vx	new_y
5	153	146	45.75
6	153	147	46.23
7	154	145	45.80
8	154	146	46.27
9	155	144	45.87
10	155	145	46.33
11	156	143	45.95
12	156	144	46.40
13	156	145	45.80
14	157	142	46.04
15	157	143	46.49
16	158	140	45.72
17	158	141	46.15
18	158	142	46.59
19	159	139	45.85
20	159	140	46.28
21	160	139	46.41
upper base	160	150	46.68

[0046] After step 18, at least first available luminance level is selected from the new luminance levels (step 20). For performing step 20 according to a preferred embodiment of the present invention, a new luminance level new_y_i of an i th gradation satisfying the aforementioned equation 3 and the following equation 6 may be determined to be a first luminance level:

$$\frac{|new_y_i - \sum_{k=1}^M new_y_k|}{new_y_i} > y_delta, (i \neq k) \quad \dots (6)$$

wherein M denotes the number of first luminance levels, in advance determined to be available.

[0047] For performing step 20 according to another embodiment of the present invention, a new luminance level new_y_i or y of an i th gradation that satisfies the following equation 7 as well as the aforementioned equations 3 and 6 may be determined as a first luminance level:

$$|yy - yx| < B(y, f) \quad \dots (7)$$

wherein f denotes the frequency of a frame, and B(,) denotes a function dependent on y and f. When the first luminance level does not satisfy the condition of the equation 7, flicker may occur. At this time, B(,) indicates the threshold value of a difference between luminance levels of two fields a user can perceive at a predetermined position on the liquid crystal display panel 46, and may vary according to the physical characteristics of liquid crystal. According to the present invention, with the frequency f fixed, B(,) can be illustrated in the form of a table while changing the new luminance level, or one value corresponding to B(,) can be measured experimentally.

[0048] After step 20, it is checked whether the gradations of an image is improved by at least one luminance level

(step 22). If it is determined that the gradations of the image is not improved, the procedure returns back to step 20. In other words, when step 12 is included in a method of improving the gradations of an image according to the present invention, it is determined that the gradations of the image is improved if the number of the gradations is increased by at least one first luminance level, and a difference between luminance levels of the gradations is regular. However, if the difference between the luminance levels is still irregular, the gradations of the image are considered as not being improved.

[0049] When the gradations of the image is determined to not be improved, y_delta is reduced, and at least one first luminance level is again selected from the new luminance levels using the reduced y_delta , in step 20.

[0050] When step 12 is included in another embodiment of the present invention, i.e., there is a need to solve for the irregularity of the luminance levels although the number of the gradations is not insufficient, the number N of the gradations can be determined in step 20, rather than in step 14. In this case, the greater the number of the gradations is set, the smaller the value of T or y_delta is set, and the smaller the number of the gradations is, the greater the value of T is set.

[0051] For steps 20 and 22, the controller 52 of FIG. 2 may be included in an image display apparatus according to the present invention. Here, the controller 52 selects at least one first luminance level from the new luminance levels which are generated by the luminance level calculator 50, as shown in FIG. 2, or generated by the liquid crystal driving voltage generator 48 unlike shown in FIG. 2, as described above. Then, the controller 52 checks whether the gradations of the image are improved using the selected first luminance level, and/or again selects the first luminance level in response to the checked result.

[0052] Hereinafter, in the event that a difference between the luminance levels of adjacent gradations is irregular although the number of gradations is not scant and the number of different sizes an image signal can have is 8 bits, i.e., 256 values, a method for improving the gradations of an image, according to the present invention, will be described.

[0053] Referring to FIG. 6, the y-axis and x-axis of a graph denote normalized luminance levels, and AC components of liquid crystal driving voltage, respectively.

[0054] First, the size of luminance levels is measured while changing the size of liquid crystal driving voltage from 0 to 255 per frame (step 10). At this time, the relationship G1 between the measured luminance level and AC components of liquid crystal driving voltage is as illustrated in FIG. 6. After step 10, only second luminance levels, which satisfy the aforementioned equation 1, are extracted from normalized luminance levels 0 - 1 (step 12). After step 12, a luminance level section that satisfies the equation 1 and in which the slope which is a change in the luminance levels of images displayed on the liquid crystal display panel 46 toward a change in liquid crystal driving voltage is steep, is determined (step 14). For instance, the range of the liquid crystal driving voltage, which corresponds to the luminance level section determined in step 14, may be from 180 to 255. After step 14, new liquid crystal driving voltage is produced per field as illustrated in table 4 (step 16). After step 16, a new luminance level of an image is measured directly from the liquid crystal display panel 46 or obtained using equation 4 (step 18). After step 18, a first luminance level satisfying equations 3 and 6, or equations 3, 6 and 7 is selected (step 20). At this time, the selected first luminance levels are inserted to a section in which a difference between luminance levels of gradations is irregular, and then, it is checked if gradations of the image are improved (step 22). If the gradations are not improved, the value of y_delta shown in equation 6 is reduced, and then, first luminance level is again selected (step 20). If it is determined that the gradations are improved, it is possible to find out the relationship G2 between the new luminance level, and the liquid crystal driving voltages except for a center voltage V_{com} , as shown in FIG. 6.

[0055] An analysis of the characteristics of gradations of an image illustrated in graphs G1 and G2 of FIG. 6 using the condition of equation 6 reveals the number N of the gradations with regard to T as shown in Table 7, assuming that A is 255.

[Table 7]

	G1				G2			
T	0.5	0.3	0.2	0.1	0.5	0.3	0.2	0.1
N	186	187	190	192	247	254	254	255

[0056] The image display apparatus of FIG. 2 is just an example of apparatuses for performing a method of improving gradations of an image, according to the present invention, illustrated in FIG. 1. Therefore, the method of FIG. 1 is not limited by the structure and operations of the image display apparatus of FIG. 2.

[0057] While the present invention has been particularly shown and described with reference to a preferred embodiment thereof, it will be understood by those skilled in the art that various changes in form and details may be made therein without departing scope of the invention as defined by the appended claims.

[0058] As described above, using a method of improving gradations of an image and an image display apparatus therefor according to the present invention, it is possible to increase the number of gradations of an image, preventing the aforementioned problems caused by the prior art. Also, irregular difference between luminance levels of gradations

can be amended to be regular. Further, this method and apparatus can be applied in amending the tone of an image in order to express substantially the gradations, thereby obtaining good quality of an image.

5 **Claims**

1. A method of improving gradations of an image carried out by a liquid crystal display including a liquid crystal driving unit for generating a liquid crystal driving signal in response to voltage, wherein the voltage is determined in accordance with the grey level of an input image signal as liquid crystal driving voltage that comprises a voltage term for a first field and a voltage term for a second field which constitutes together a unit frame, and a liquid crystal display panel for being driven in response to the liquid crystal driving signal and displaying the image, the method comprising steps of:

- 15 (a) measuring (10) luminance levels displayed on the liquid crystal display panel while changing the stored driving voltages for the first and second fields of the frame corresponding to each possible input image gradation;
- (b) determining (14) at least one luminance level section whose gradations needs to be improved from the measured luminance levels by checking a slope corresponding to a change in the luminance levels of the image displayed on the liquid crystal display panel to a change in the corresponding liquid crystal driving voltages, the luminance level section including at least two gradations;
- 20 (c) producing (16) new liquid crystal driving voltages by increasing or decreasing the liquid crystal driving voltage generating the lowest luminance level of the luminance levels of the luminance level section for each of the first and second fields in each determined luminance level section;
- (d) obtaining (18) new luminance levels using the produced new liquid crystal driving voltages and adding said levels to the levels measured in step (a);
- 25 (e) selecting (20) at least one available luminance level from the new luminance levels; and
- (f) checking (21) whether the gradations of the image are improved using the available luminance level by checking whether a difference in the luminance levels of adjacent gradients in the luminance section level is regular, and/or returning back to step (e) if the gradations are not improved.

30 2. The method of claim 1 further comprising step of (g) extracting (12) second available luminance levels using a difference between luminance levels of adjacent gradations from the measured luminance levels after step (a), and then performing step (b), wherein in step (b), the luminance level section is selected from the second luminance levels after step (g).

35 3. The method of claim 2, wherein step (g) comprises determining (12) the luminance levels y_a and y_b of the adjacent gradations, which satisfy the following formula, as the second luminance levels:

40
$$\frac{|y_a - y_b|}{y_a} > y_{\text{delta}},$$

wherein y_{delta} denotes T/A , A denotes the number of different luminance levels pixel of the image displayed can have, and T denotes an allowable tolerance factor that is smaller than 1.

45 4. The method of claim 3, wherein in step (b), the number of gradations of each luminance level section determined is determined.

50 5. The method of claim 4, wherein in step (b) a reference table and a measurement table are compared with each other, and the number of the gradations is determined using the comparison result, and the measurement table is a table to which the luminance levels measured, and the liquid crystal driving voltages changed per frame in step (a) are written, and the reference table is a table to which the liquid crystal driving voltages and reference luminance levels were written in advance.

55 6. The method of any of claims 2 to 5, wherein in step (e) the number of the gradations in each luminance level determined is determined.

7. The method of any of claims 2 to 6, wherein the new liquid crystal driving voltages produced in step (c) satisfies the

formula:

$$|v_x - v_y| < V_threshold ,$$

wherein v_x and v_y denote AC components of the new liquid crystal driving voltages for the first and second fields, and $V_threshold$ denotes a voltage critical value that the liquid crystal display panel permits.

8. The method of claim 7, wherein in step (c) the new liquid crystal driving voltage is produced in a limited range using the relationship between the luminance levels measured in step (a) and the liquid crystal driving voltages, and the formula:

$$y_0 < new_y < y_1 ,$$

wherein y_0 and y_1 denote the lowest and highest luminance levels in each luminance level section, and new_y denotes the new luminance level.

9. The method of any preceding claim, wherein in step (d) the new luminance levels new_y are obtained using the new liquid crystal driving voltages as follows:

$$new_y = yy * tf_1 + yx * tf_2 ,$$

wherein $yy = G(v_y)$, $yx = G(v_x)$, v_y and v_x denote AC components of the new liquid crystal driving voltages for the first and second fields, $G()$ denotes a gamma function varying according to the type of liquid crystal used in the image display apparatus, and tf_1 and tf_2 denote periodic rates of the first and second fields.

10. The method of claim 1, wherein in step (d) the luminance level of the image displayed on the liquid crystal display panel driven by the liquid crystal driving signal generated in response to the new liquid crystal driving voltages, is determined as the new luminance level.

11. The method of any preceding claim, wherein in step (e) the new luminance level new_y_i of an i th gradation, which satisfies the following formula, is determined as the first luminance level:

$$y_0 < new_y_i < y_1 \text{ and } \frac{|new_y_i - \sum_{k=1}^M new_y_k|}{new_y_i} > y_delta, (i \neq k),$$

wherein y_0 and y_1 denote the lowest and highest luminance levels in each luminance level section, respectively, M denotes the number of the first luminance levels which is determined in advance, y_delta denotes T/A , A denotes the number of different luminance levels the pixel of the image displayed can have, and T denotes an allowable tolerance factor that is smaller than 1.

12. The method of claim 11, wherein in step (e) if it is determined that the gradations of the image are not improved, y_delta is reduced, and the first luminance level is again selected from the new luminance levels, using the reduced y_delta .

13. The method of claim 11, wherein in step (e) the new luminance level y , which further satisfies the following formula, is determined as the first luminance level:

$$|y_y - y_x| < B(y, f),$$

5 wherein $y_y = G(y_y)$, $y_x = G(y_x)$, y_y and y_x denote AC components of the new liquid crystal driving voltages for the first and second fields, $G(\)$ denotes a gamma function changing according to the type of liquid crystal used in the image display apparatus, f denotes the frequency of the frame, and $B(\)$ denotes a function depending on y and f .

10 **14.** A liquid crystal display for performing the method of improving gradations of an image as claimed in claim 1, the liquid crystal display comprising:

a first storage unit (40) for reading out voltage in accordance to the image of each gradation from the liquid crystal driving voltages stored with respect to the first field, in response to a first control signal;
 15 a second storage unit (42) for reading out voltage in accordance to the image of each gradation from the liquid crystal driving voltages stored with respect to the second field, in response to a second control signal;
 a liquid crystal driving unit (44) for generating a liquid crystal driving signal in response to the liquid crystal driving voltage read out by the first or second storage unit;
 a liquid crystal driving voltage generator (48) for measuring the luminance levels of the image of each gradation displayed on the liquid crystal display panel, and for generating the new liquid crystal driving voltages for each
 20 of the first and second fields in each luminance level section extracted from the measured luminance levels; and
 a controller (52) for alternately generating one of the first and second control signals in the unit of field, selecting at least available luminance level from the new luminance levels, checking whether gradations of the image is improved based on the selected available luminance level, and again selecting the available luminance level
 25 in response to the checked result,
 wherein the first and second storage units (40, 42) are arranged to update the stored liquid crystal driving voltages by adding the new liquid crystal driving voltages generated by the liquid crystal driving voltage generator.

30 **15.** The liquid crystal display of claim 14, wherein the liquid crystal driving voltage generator (48) extracts only available second luminance levels from the measured luminance levels using a difference between the luminance levels of adjacent gradations, and determines the luminance level section from the second luminance levels.

35 **16.** The liquid crystal display of claim 14 or 15 further comprising a luminance level generator (50) for generating the new luminance levels from the new liquid crystal driving voltages generated by the liquid crystal driving voltage generator, and for outputting the generated new luminance levels to the controller.

40 **17.** The liquid crystal display of claim 14, 15 or 16, wherein the liquid crystal driving voltage generator (48) measures the luminance level of the image displayed on the liquid crystal display panel in response to the new liquid crystal driving voltage as the new luminance level, and outputs the measured new luminance level of the image to the controller.

Patentansprüche

45 **1.** Verfahren zur Gradationsverbesserung eines Bilds, das von einer Flüssigkristallanzeige ausgeführt wird, die eine Flüssigkristalltreibereinheit zum Erzeugen eines Flüssigkristalltreibersignals in Abhängigkeit von einer Spannung, wobei die Spannung gemäß dem Grauwert eines Eingabebildsignals als Flüssigkristalltreiberspannung bestimmt wird, die einen Spannungsterm für ein erstes Feld und einen Spannungsterm für ein zweites Feld umfasst, die zusammen eine Rahmeneinheit bilden, und einen Flüssigkristallanzeigeschirm aufweist, der in Abhängigkeit vom Flüssigkristalltreibersignal betrieben wird und das Bild anzeigt, wobei das Verfahren die Schritte umfasst:

- 50 (a) Messen (10) von Luminanzpegeln, die auf dem Flüssigkristallanzeigeschirm angezeigt werden, während die gespeicherten Treiberspannungen für das erste und zweite Feld des Rahmens, die jeder möglichen Eingabebildgradation entsprechen, verändert werden,
 (b) Bestimmen (14) mindestens einer Luminanzpegelsektion, deren Gradationen verbessert werden müssen,
 55 aus den gemessenen Luminanzpegeln durch Prüfen einer Steigung, die einer Änderung der Luminanzpegel des auf dem Flüssigkristallanzeigeschirm angezeigten Bilds entspricht, auf eine Änderung der zugehörigen Flüssigkristalltreiberspannungen, wobei die Luminanzpegelsektion mindestens zwei Gradationen aufweist,
 (c) Bilden (16) neuer Flüssigkristalltreiberspannungen durch Erhöhen oder Senken der Flüssigkristalltreiber-

EP 1 315 141 B1

spannung, die den niedrigsten Luminanzpegel der Luminanzpegelsektion für das erste und zweite Feld in jeder bestimmten Luminanzpegelsektion erzeugt,
(d) Ermitteln (18) neuer Luminanzpegel unter Verwendung der gebildeten neuen Flüssigkristalltreiberspannungen und hinzufügen dieser Pegel zu den in Schritt (a) gemessenen Pegeln,
5 (e) Auswählen (20) mindestens eines verfügbaren Luminanzpegels aus den neuen Luminanzpegeln und
(f) Prüfen (21), ob die Gradationen des Bilds verbessert sind, unter Verwendung des verfügbaren Luminanzpegels durch Prüfen, ob eine Differenz bei den Luminanzpegeln benachbarter Gradienten im Luminanzsektionspegel regulär ist, und/oder Rückkehr zu Schritt (e), wenn die Gradationen nicht verbessert sind.

10 **2.** Verfahren nach Anspruch 1, weiter umfassend Schritt (g) zum Extrahieren (12) zweiter verfügbarer Luminanzpegel unter Verwendung einer Differenz zwischen Luminanzpegeln benachbarter Gradationen aus den gemessenen Luminanzpegeln nach Schritt (a) und dann Durchführen von Schritt (b), wobei in Schritt (b) die Luminanzpegelsektion aus den zweiten Luminanzpegeln nach Schritt (g) ausgewählt wird.

15 **3.** Verfahren nach Anspruch 2, wobei Schritt (g) umfasst:

Bestimmen (12) der Luminanzpegel y_a und y_b der benachbarter Gradationen, die die folgende Formel erfüllen, als die zweiten Luminanzpegel

20

$$\frac{|y_a - y_b|}{y_a} > y_{\text{delta}},$$

25

wobei y_{delta} T/A bezeichnet, A die Anzahl unterschiedlicher Luminanzpegel bezeichnet, die Pixel des angezeigten Bildes aufweisen können, und T einen zulässigen Toleranzfaktor bezeichnet, der kleiner ist als 1.

30 **4.** Verfahren nach Anspruch 3, wobei in Schritt (b) die Anzahl an Gradationen jeder bestimmten Luminanzpegelsektion bestimmt wird.

35

5. Verfahren nach Anspruch 4, wobei in Schritt (b) eine Referenztablette und eine Messtabelle miteinander verglichen werden und die Anzahl an Gradationen unter Verwendung des Vergleichsergebnisses bestimmt wird und die Messtabelle eine Tabelle ist, in die die gemessenen Luminanzpegel und die pro Rahmen in Schritt (a) geänderten Flüssigkristalltreiberspannungen eingeschrieben werden, und die Referenztablette eine Tabelle ist, in die die Flüssigkristalltreiberspannungen und Referenzluminanzpegel zuvor eingeschrieben wurden.

40

6. Verfahren nach einem der Ansprüche 2 bis 5, wobei in Schritt (e) die Anzahl an Gradationen in jedem bestimmten Luminanzpegel bestimmt wird.

45

7. Verfahren nach einem der Ansprüche 2 bis 6, wobei die in Schritt (c) gebildeten neuen Flüssigkristalltreiberspannungen die Formel erfüllen:

$$|v_x - v_y| < V_{\text{Schwelle}},$$

50

wobei v_x und v_y AC-Komponenten der neuen Flüssigkristalltreiberspannungen für das erste und zweite Feld bezeichnen und V_{Schwelle} einen kritischen Spannungswert bezeichnet, den der Flüssigkristallanzeigeschirm zulässt.

55 **8.** Verfahren nach Anspruch 7, wobei in Schritt (c) die neue Flüssigkristalltreiberspannung in einem begrenzten Bereich unter Verwendung der Beziehung zwischen den in Schritt (a) gemessenen Luminanzpegeln und den Flüssigkristalltreiberspannungen und der Formel gebildet wird:

60

$$y_0 < \text{neu}_y < y_1,$$

wobei y_0 und y_1 den niedrigsten und höchsten Luminanzpegel in jeder Luminanzpegelsektion bezeichnen und neu_y

y den neuen Luminanzpegel bezeichnet.

9. Verfahren nach einem der vorhergehenden Ansprüche, wobei in Schritt (d) die neuen Luminanzpegel neu_y unter Verwendung der neuen Flüssigkristalltreiberspannungen wie folgt ermittelt werden:

5

$$neu_y = yy * tf_1 + yx * tf_2,$$

10 wobei yy = G(vy), yx = G(vx), vy und vx AC-Komponenten der neuen Flüssigkristalltreiberspannungen für das erste und zweite Feld bezeichnen, G() eine Gamma-Funktion bezeichnet, die gemäß dem Typ des im Bildanzeigegerät verwendeten Flüssigkristalls variiert, und tf_1 und tf_2 periodische Raten des ersten und zweiten Felds bezeichnen.

- 10 10. Verfahren nach Anspruch 1, wobei in Schritt (d) der Luminanzpegel des auf dem Flüssigkristallanzeigeschirm angezeigten Bilds, der vom Flüssigkristalltreibersignal getrieben wird, das in Abhängigkeit von den neuen Flüssigkristalltreiberspannungen erzeugt ist, als der neue Luminanzpegel bestimmt wird.

11. Verfahren nach einem der vorhergehenden Ansprüche, wobei in Schritt (e) der neue Luminanzpegel neu_y_i einer i-ten Gradation, die die folgende Formel erfüllt, als der erste Luminanzpegel bestimmt wird:

20

$$y_0 < neu_y_i < y_1 \text{ und } \frac{\left| neu_y_i - \sum_{k=1}^M neu_y_k \right|}{neu_y_i} > y_delta, (i \neq k),$$

25

wobei y_0 und y_1 den niedrigsten bzw. höchsten Luminanzpegel in jeder Luminanzpegelsektion bezeichnen, M die Anzahl der ersten Luminanzpegel bezeichnet, die zuvor bestimmt ist, y_delta T/A bezeichnet, A die Anzahl unterschiedlicher Luminanzpegel bezeichnet, die Pixel des angezeigten Bilds aufweisen können, und T einen verfügbaren Toleranzfaktor bezeichnet, der kleiner ist als 1.

30

12. Verfahren nach Anspruch 11, wobei in Schritt (e), wenn bestimmt ist, dass die Gradationen des Bilds nicht verbessert sind, y_delta verringert wird und der erste Luminanzpegel aus den neuen Luminanzpegel unter Verwendung des verringerten y_delta erneut ausgewählt wird.

35

13. Verfahren nach Anspruch 11, wobei in Schritt (e) der neue Luminanzpegel y, der weiter die folgende Formel erfüllt, als der erste Luminanzpegel bestimmt wird:

40

$$|yy - yx| < B(y, f),$$

wobei yy=G(vy), yx=G(vx), vy und vx AC-Komponenten der neuen Flüssigkristalltreiberspannungen für das erste und zweite Feld bezeichnen, G() eine Gamma-Funktion bezeichnet, die gemäß dem Typ des im Bildanzeigegerät verwendeten Flüssigkristalls variiert, f die Frequenz des Rahmens bezeichnet und B(,) eine Funktion in Abhängigkeit von y und f bezeichnet.

45

14. Flüssigkristallanzeige zum Durchführen des Verfahrens zur Gradationsverbesserung eines Bilds nach Anspruch 1, wobei die Flüssigkristallanzeige umfasst: eine erste Speichereinheit (40) zum Auslesen einer Spannung gemäß dem Bild jeder Gradation aus den Flüssigkristalltreiberspannungen, die in Bezug auf das erste Feld gespeichert sind, in Abhängigkeit von einem ersten Steuersignal, eine zweite Speichereinheit (42) zum Auslesen einer Spannung gemäß dem Bild jeder Gradation aus den Flüssigkristalltreiberspannungen, die in Bezug auf das zweite Feld gespeichert sind, in Abhängigkeit von einem zweiten Steuersignal, eine Flüssigkristalltreibereinheit (44) zum Erzeugen eines Flüssigkristalltreibersignals in Abhängigkeit von der Flüssigkristalltreiberspannung, die aus der ersten oder zweiten Speichereinheit ausgelesen worden ist, einen Flüssigkristalltreiberspannungsgenerator (48) zum Messen der Luminanzpegel des Bilds jeder Gradation, das auf dem Flüssigkristallanzeigeschirm angezeigt ist, und zum Erzeugen neuer Flüssigkristalltreiberspannungen für das erste und

55

zweite Feld in jeder Luminanzpegelsektion, die aus den gemessenen Luminanzpegeln extrahiert sind, und eine Steuereinheit (52) zum abwechselnden Erzeugen des ersten oder zweiten Steuersignals in der Feldeinheit, Auswählen eines mindestens verfügbaren Luminanzpegels aus den neuen Luminanzpegeln, Prüfen, ob Gradationen des Bilds verbessert sind, basierend auf dem ausgewählten verfügbaren Luminanzpegel und erneutes Auswählen des verfügbaren Luminanzpegels in Abhängigkeit vom Prüfergebnis, wobei die erste und zweite Speichereinheit (40, 42) dazu ausgebildet sind, die gespeicherten Flüssigkristalltreiberspannungen durch Hinzufügen der vom Flüssigkristalltreiberspannungsgenerator erzeugten neuen Flüssigkristalltreiberspannungen fortzuschreiben.

- 5
- 10 **15.** Flüssigkristallanzeige nach Anspruch 14, wobei der Flüssigkristalltreiberspannungsgenerator (48) nur verfügbare zweite Luminanzpegel aus den gemessenen Luminanzpegeln unter Verwendung einer Differenz zwischen den Luminanzpegeln benachbarter Gradienten extrahiert und die Luminanzpegelsektion aus den zweiten Luminanzpegeln bestimmt.
- 15 **16.** Flüssigkristallanzeige nach Anspruch 14 oder 15, weiter umfassend einen Luminanzpegelgenerator (50) zum Erzeugen der neuen Luminanzpegel aus den neuen Flüssigkristalltreiberspannungen, die vom Flüssigkristalltreiberspannungsgenerator erzeugt sind, und zum Abgeben der erzeugten neuen Luminanzpegel an die Steuereinheit.
- 20 **17.** Flüssigkristallanzeige nach Anspruch 14, 15 oder 16, wobei der Flüssigkristalltreiberspannungsgenerator (48) den Luminanzpegel des auf dem Flüssigkristallanzeigeschirm angezeigten Bilds in Abhängigkeit von der neuen Flüssigkristalltreiberspannung als den neuen Luminanzpegel misst und den gemessenen neuen Luminanzpegel des Bilds an die Steuereinheit ausgibt.

25 **Revendications**

- 30 **1.** Procédé d'amélioration des gradations d'une image effectuées par un afficheur à cristaux liquides comprenant une unité de commande de cristaux liquides pour générer un signal de commande de cristaux liquides en réponse à une tension, dans lequel la tension est déterminée en fonction du niveau de gris d'un signal d'image d'entrée en tant que tension de commande de cristaux liquides qui comprend un terme de tension pour un premier champ et un terme de tension pour un deuxième champ qui constituent, ensemble, une trame unitaire, et un panneau d'affichage à cristaux liquides à commander en réponse au signal de commande de cristaux liquides et pour afficher l'image, le procédé comprenant les étapes consistant à :
- 35 (a) mesurer (10) les niveaux de luminance affichés sur le panneau d'affichage à cristaux liquides tout en modifiant les tensions de commande mémorisées pour les premier et deuxième champs de la trame correspondant à chaque gradation d'image d'entrée possible;
- 40 (b) déterminer (14) au moins une section de niveau de luminance dont les gradations doivent être améliorées à partir des niveaux de luminance mesurés en vérifiant une pente correspondant à une variation des niveaux de luminance de l'image affichée sur le panneau d'affichage à cristaux liquides pour une variation des tensions de commande de cristaux liquides correspondantes, la section de niveau de luminance comprenant au moins deux gradations ;
- 45 (c) produire (16) de nouvelles tensions de commande de cristaux liquides en augmentant ou en diminuant la tension de commande de cristaux liquides générant le niveau de luminance le plus faible parmi les niveaux de luminance de la section de niveau de luminance pour chacun des premier et deuxième champs dans chaque section de niveau de luminance déterminée ;
- (d) obtenir (18) de nouveaux niveaux de luminance en utilisant les nouvelles tensions de commande de cristaux liquides produites et ajouter lesdits niveaux aux niveaux mesurés à l'étape (a) ;
- 50 (e) sélectionner (20) au moins un niveau de luminance disponible parmi les nouveaux niveaux de luminance ; et
- (f) vérifier (21) si les gradations de l'image sont améliorées en utilisant le niveau de luminance disponible en vérifiant si une différence des niveaux de luminance de gradients adjacents dans le niveau de section de luminance est régulière, et/ou retourner à l'étape (e) si les gradations ne sont pas améliorées.
- 55 **2.** Procédé selon la revendication 1 comprenant en outre une étape (g) d'extraction (12) de deuxièmes niveaux de luminance disponibles en utilisant une différence entre les niveaux de luminance de gradations adjacentes des niveaux de luminance mesurés après l'étape (a), et effectuer ensuite l'étape (b), dans lequel, à l'étape (b), la section de niveau de luminance est sélectionnée parmi les deuxièmes niveaux de luminance après l'étape (g).

EP 1 315 141 B1

3. Procédé selon la revendication 2, dans lequel l'étape (g) comprend la détermination (12) des niveaux de luminance y_a et y_b des gradations adjacentes, qui satisfont à la formule suivante, en tant que deuxièmes niveaux de luminance :

5

$$\frac{|y_a - y_b|}{y_a} > y_{\Delta},$$

10 où y_{Δ} désigne T/A , A désigne le nombre de niveaux de luminance différents qu'un pixel de l'image affichée peut avoir, et T désigne un facteur de tolérance admissible qui est inférieur à 1.

4. Procédé selon la revendication 3, dans lequel, à l'étape (b), le nombre de gradations de chaque section de niveau de luminance déterminée est déterminé.

15

5. Procédé selon la revendication 4, dans lequel, à l'étape (b), une table de référence et une table de mesure sont comparées l'une à l'autre, et le nombre des gradations est déterminé en utilisant le résultat de la comparaison, et la table de mesure est une table dans laquelle les niveaux de luminance mesurés, et les tensions de commande de cristaux liquides modifiées par trame à l'étape (a) sont écrits, et la table de référence est une table dans laquelle les tensions de commande de cristaux liquides et les niveaux de luminance de référence ont été écrits à l'avance.

20

6. Procédé selon l'une quelconque des revendications 2 à 5, dans lequel, à l'étape (e), le nombre des gradations dans chaque niveau de luminance déterminé est déterminé.

25

7. Procédé selon l'une quelconque des revendications 2 à 6, dans lequel les nouvelles tensions de commande de cristaux liquides produites à l'étape (c) satisfont à la formule :

30

$$|v_x - v_y| < V_{\text{threshold}},$$

où v_x et v_y désignent les composantes alternatives des nouvelles tensions de commande de cristaux liquides pour les premier et deuxième champs, et $V_{\text{threshold}}$ désigne une valeur critique de tension que le panneau d'affichage à cristaux liquides permet.

35

8. Procédé selon la revendication 7, dans lequel, à l'étape (c), la nouvelle tension de commande de cristaux liquides est produite dans une plage limitée en utilisant la relation entre les niveaux de luminance mesurés à l'étape (a) et les tensions de commande de cristaux liquides, et la formule :

40

$$y_0 < \text{new}_y < y_1,$$

45 où y_0 et y_1 désignent les niveaux de luminance le plus faible et le plus élevé dans chaque section de niveau de luminance, et new_y désigne le nouveau niveau de luminance.

9. Procédé selon l'une quelconque des revendications précédentes, dans lequel, à l'étape (d), les nouveaux niveaux de luminance new_y sont obtenus en utilisant les nouvelles tensions de commande de cristaux liquides comme suit :

50

$$\text{new}_y = yy * tf_1 + yx * tf_2,$$

55 où $yy = G(v_y)$, $yx = G(v_x)$, v_y et v_x désignent les composantes alternatives des nouvelles tensions de commande de cristaux liquides pour les premier et deuxième champs, $G()$ désigne une fonction gamma qui varie en fonction du type de cristal liquide utilisé dans le dispositif d'affichage d'image, et tf_1 et tf_2 désignent les fréquences périodiques des premier et deuxième champs.

EP 1 315 141 B1

10. Procédé selon la revendication 1, dans lequel, à l'étape (d), le niveau de luminance de l'image affichée sur le panneau d'affichage à cristaux liquides commandé par le signal de commande de cristaux liquides généré en réponse aux nouvelles tensions de commande de cristaux liquides, est déterminé en tant que nouveau niveau de luminance.

5

11. Procédé selon l'une quelconque des revendications précédentes, dans lequel, à l'étape (e), le nouveau niveau de luminance new_y_i d'une i^{e} gradation, qui satisfait à la formule suivante, est déterminé en tant que premier niveau de luminance :

10

$$y_0 < new_y_i < y_1 \text{ and } \frac{|new_y_i - \sum_{k=1}^M new_y_k|}{new_y_i} > y_delta, (i \neq k).$$

15 où y_0 et y_1 désignent les niveaux de luminance le plus faible et le plus élevé dans chaque section de niveau de luminance, respectivement, M désigne le nombre des premiers niveaux de luminance qui est déterminé à l'avance, y_delta désigne T/A , A désigne le nombre de niveaux de luminance différents que le pixel de l'image affichée peut avoir, et T désigne un facteur de tolérance admissible qui est inférieur à 1.

20 12. Procédé selon la revendication 11, dans lequel, à l'étape (e), s'il est déterminé que les gradations de l'image ne sont pas améliorées, y_delta est réduit, et le premier niveau de luminance est de nouveau sélectionné parmi les nouveaux niveaux de luminance, en utilisant le y_delta réduit.

25 13. Procédé selon la revendication 11, dans lequel, à l'étape (e), le nouveau niveau de luminance y , qui satisfait en outre à la formule suivante, est déterminé en tant que premier niveau de luminance :

30

$$|yy - yx| < B(y, f),$$

où $yy = G(yx)$, $yx = G(vx)$, vy et vx désignent les composantes alternatives des nouvelles tensions de commande de cristaux liquides pour les premier et deuxième champs, $G()$ désigne une fonction gamma qui varie en fonction du type de cristal liquide utilisé dans le dispositif d'affichage d'image, f désigne la fréquence de la trame, et $B(.,.)$ désigne une fonction dépendant de y et de f .

35

14. Afficheur à cristaux liquides pour effectuer le procédé d'amélioration des gradations d'une image selon la revendication 1, l'afficheur à cristaux liquides comprenant :

40

une première unité de mémorisation (40) pour extraire une tension en fonction de l'image de chaque gradation des tensions de commande de cristaux liquides mémorisées en relation avec le premier champ, en réponse à un premier signal de commande ;

une deuxième unité de mémorisation (42) pour extraire une tension en fonction de l'image de chaque gradation des tensions de commande de cristaux liquides mémorisées en relation avec le deuxième champ, en réponse à un deuxième signal de commande ;

45

une unité de commande de cristaux liquides (44) pour générer un signal de commande de cristaux liquides en réponse à la tensions de commande de cristaux liquides extraite par la première ou la deuxième unité de mémorisation ;

50

un générateur de tension de commande de cristaux liquides (48) pour mesurer les niveaux de luminance de l'image de chaque gradation affichée sur le panneau d'affichage à cristaux liquides, et pour générer les nouvelles tensions de commande de cristaux liquides pour chacun des premier et deuxième champs dans chaque section de niveau de luminance extraite des niveaux de luminance mesurer; et

55

un contrôleur (52) pour générer alternativement l'un des premier et deuxième signaux de commande dans l'unité de champ, sélectionner au moins un niveau de luminance disponible parmi les nouveaux niveaux de luminance, vérifier si les gradations de l'image sont améliorées sur la base du niveau de luminance disponible sélectionné, et sélectionner de nouveau le niveau de luminance disponible en réponse au résultat vérifié, dans lequel les première et deuxième unités de mémorisation (40, 42) sont agencées pour mettre à jour les tensions de commande de cristaux liquides mémorisées en ajoutant les nouvelles tensions de commande de cristaux liquides générées par le générateur de tension de commande de cristaux liquides.

EP 1 315 141 B1

15. Afficheur à cristaux liquides selon la revendication 14, dans lequel le générateur de tension de commande de cristaux liquides (48) n'extrait que les deuxièmes niveaux de luminance disponibles des niveaux de luminance mesurés en utilisant une différence entre les niveaux de luminance de gradations adjacentes, et détermine la section de niveau de luminance à partir des deuxièmes niveaux de luminance.

5
16. Afficheur à cristaux liquides selon la revendication 14 ou 15 comprenant en outre un générateur de niveau de luminance (50) pour générer les nouveaux niveaux de luminance à partir des nouvelles tensions de commande de cristaux liquides générées par le générateur de tension de commande de cristaux liquides, et pour délivrer les nouveaux niveaux de luminance générés au contrôleur.

10
17. Afficheur à cristaux liquides selon la revendication 14, 15 ou 16, dans lequel le générateur de tension de commande de cristaux liquides (48) mesure le niveau de luminance de l'image affichée sur le panneau d'affichage à cristaux liquides en réponse à la nouvelles tension de commande de cristaux liquides en tant que nouveau niveau de luminance, et délivre le nouveau niveau de luminance mesuré de l'image au contrôleur.

15

20

25

30

35

40

45

50

55

FIG. 1

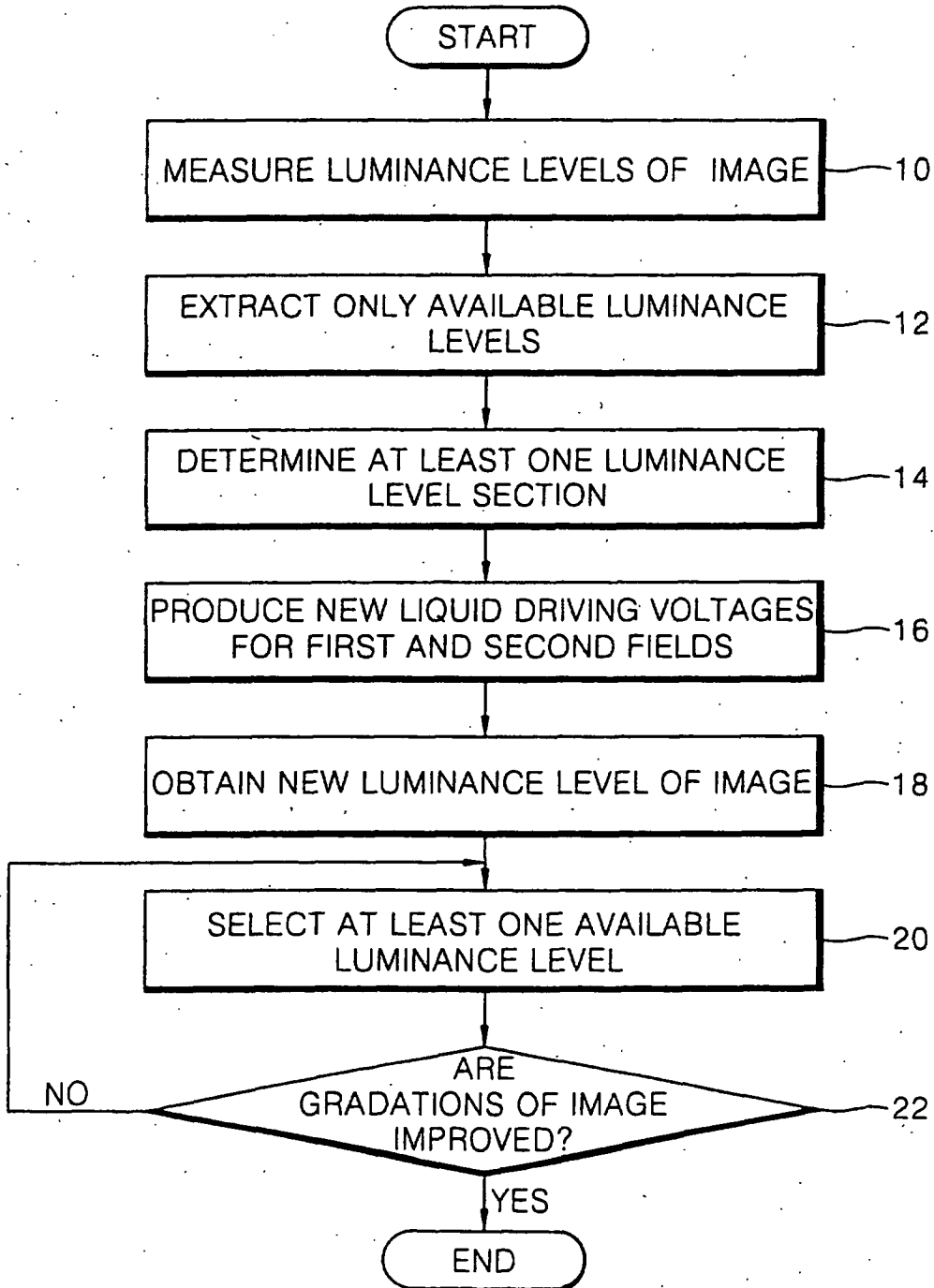

FIG. 2

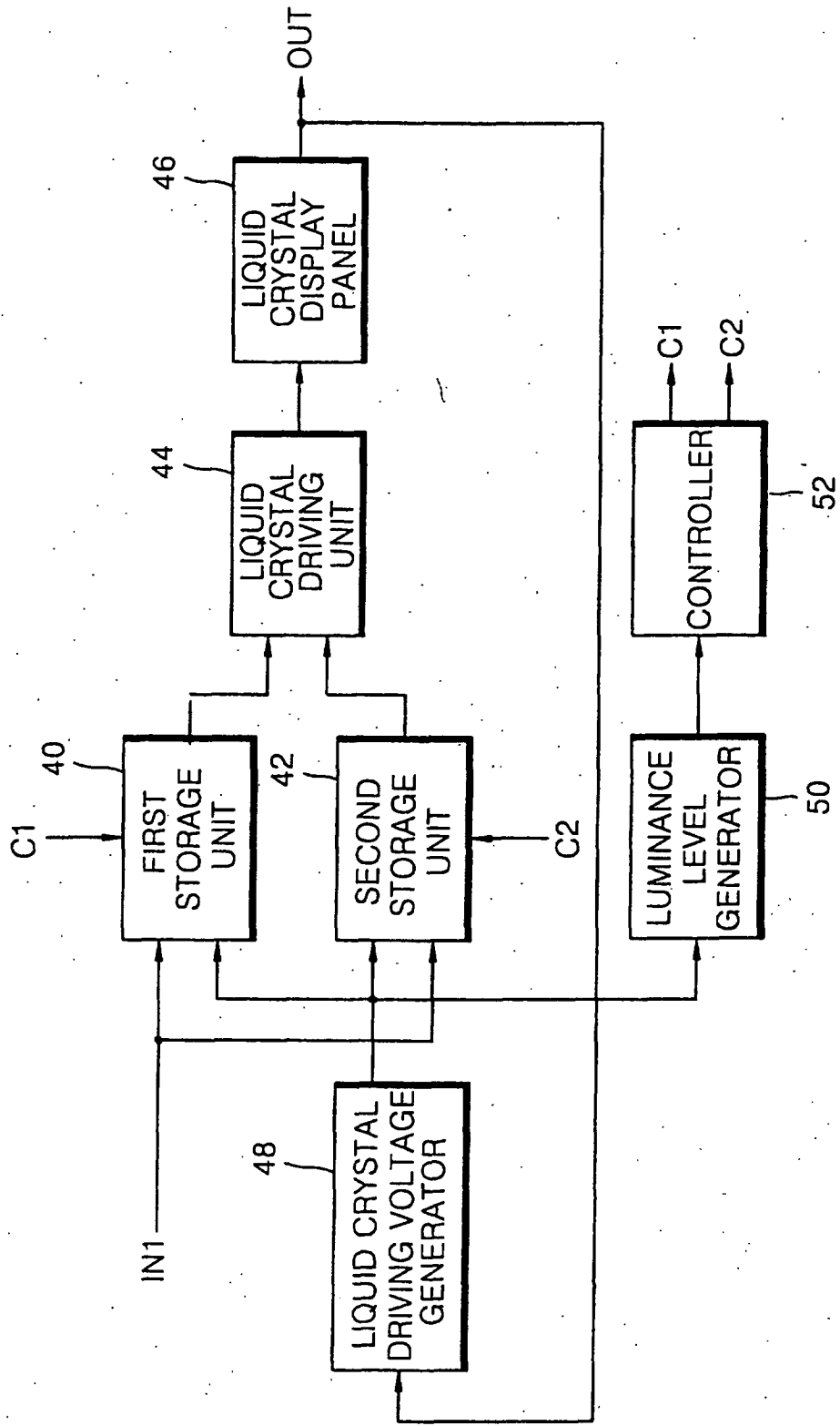

FIG. 3

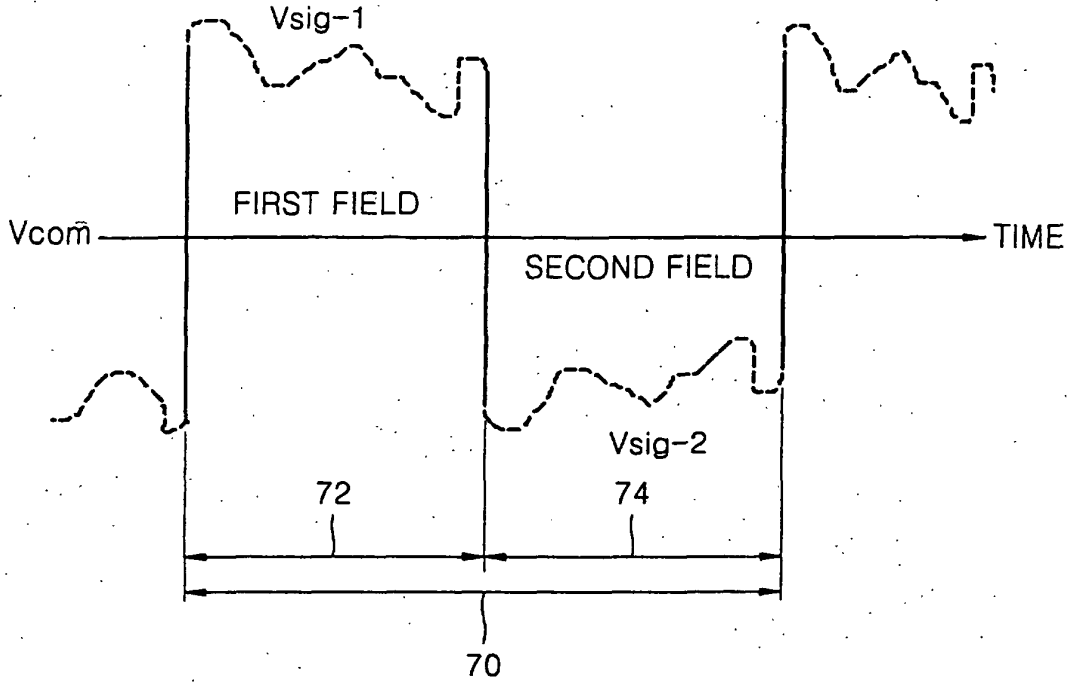

FIG. 4

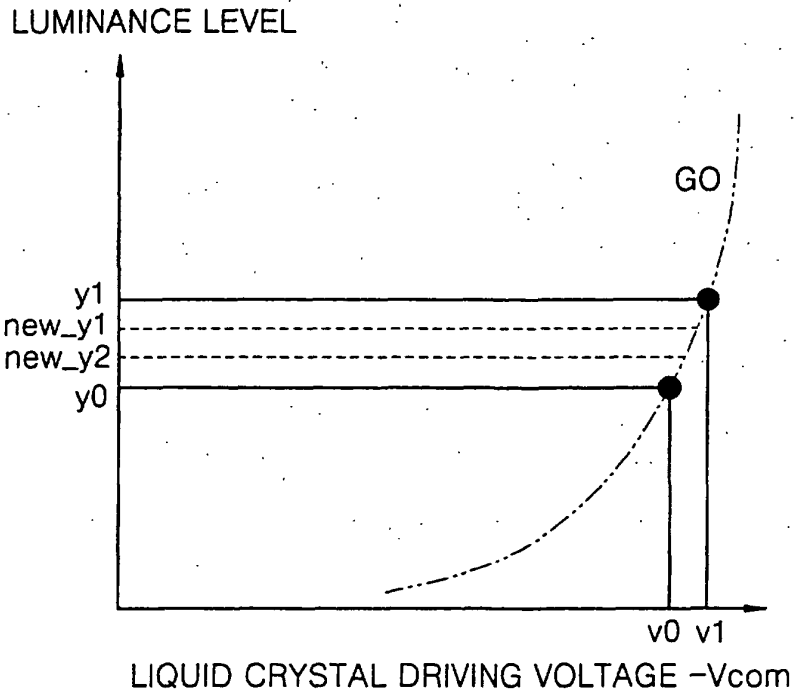

FIG. 5

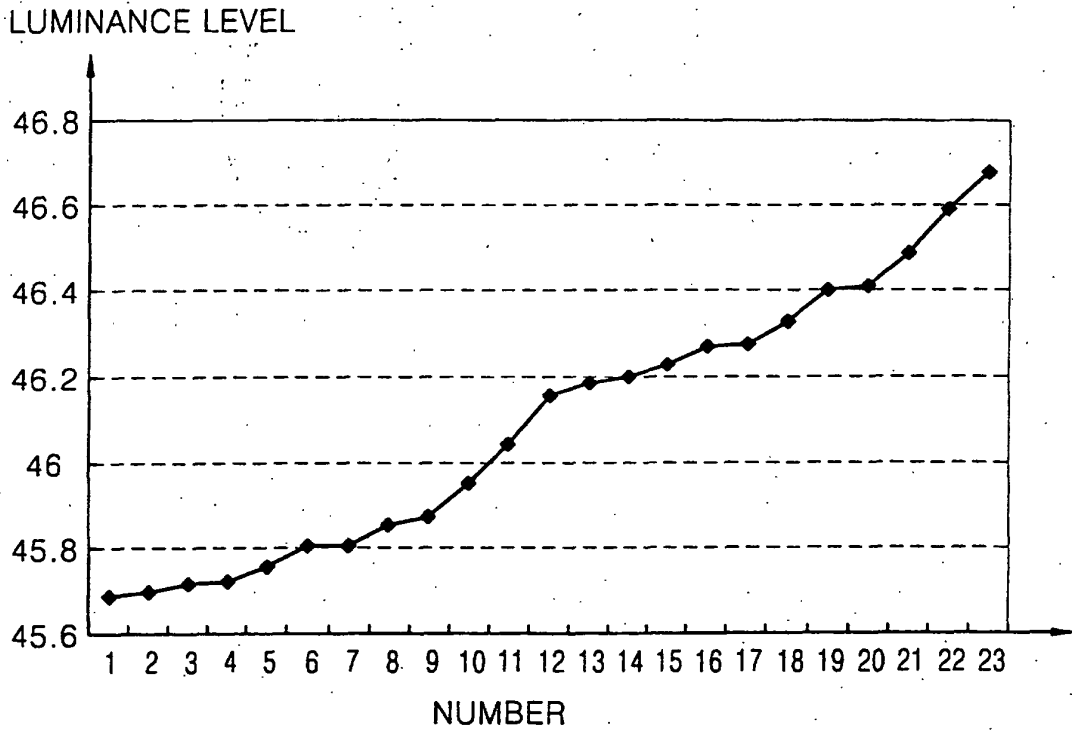
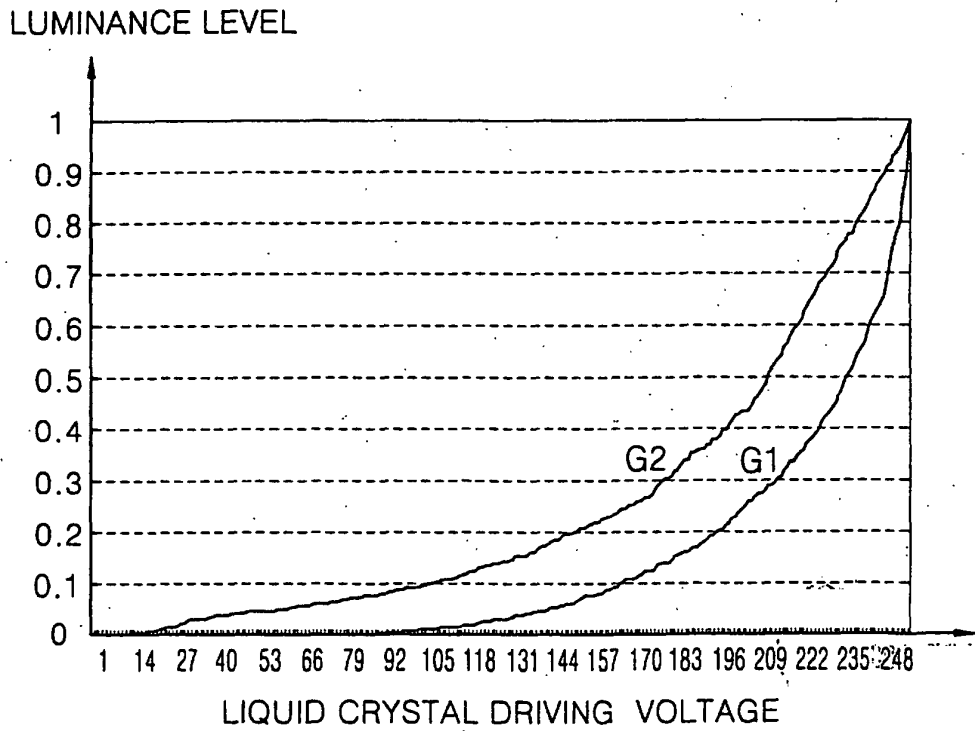

FIG. 6



REFERENCES CITED IN THE DESCRIPTION

This list of references cited by the applicant is for the reader's convenience only. It does not form part of the European patent document. Even though great care has been taken in compiling the references, errors or omissions cannot be excluded and the EPO disclaims all liability in this regard.

Patent documents cited in the description

- US 3937878 A [0004]
- US 5162925 A [0004]
- US 4921334 A [0006]
- US 5953002 A [0009]

专利名称(译)	用于改善图像灰度的方法和用于执行该方法的图像显示装置		
公开(公告)号	EP1315141B1	公开(公告)日	2010-09-15
申请号	EP2002257343	申请日	2002-10-23
[标]申请(专利权)人(译)	三星电子株式会社 三星电机株式会社		
申请(专利权)人(译)	SAMSUNG ELECTRONICS CO. , LTD. 三星机电CO.LTD.		
当前申请(专利权)人(译)	SAMSUNG ELECTRONICS CO. , LTD. 三星机电CO.LTD.		
[标]发明人	LEE SEONG DEOK KIM CHANG YEONG 502 1305 JINSAN MAEUL SAMSUNG		
发明人	LEE, SEONG-DEOK KIM, CHANG-YEONG, 502-1305 JINSAN MAEUL SAMSUNG		
IPC分类号	G09G3/36 G02F1/133 G09G3/20 H04N5/66		
CPC分类号	G09G3/3611 G09G3/2081 G09G3/3614 G09G2320/0271 G09G2320/0276 G09G2320/029 G09G2320/066 G09G2320/0693		
优先权	1020010067625 2001-10-31 KR		
其他公开文献	EP1315141A3 EP1315141A2		
外部链接	Espacenet		

摘要(译)

提供了一种提高图像的灰度的方法和用于执行该方法的图像显示装置。该方法是改进由液晶显示器执行的图像的灰度，该液晶显示器包括液晶驱动单元，用于响应于根据来自液晶驱动的图像信号的大小而选择的电压产生液晶驱动信号由构成单位帧的第一和第二场分类的电压，以及响应于液晶驱动信号被驱动并显示图像的液晶显示面板，所述方法包括：
 (a) 测量所显示的图像的亮度水平，在改变每帧的液晶驱动电压的同时改变液晶显示面板；(b) 从所测量的亮度级确定需要改进其灰度的至少一个亮度级部分；(c) 产生以每个确定的亮度级部分中的每个第一和第二场的最低亮度级相关的液晶驱动电压为中心增加或减少的新的液晶驱动电压；(d) 使用产生的新的液晶驱动电压获得新的亮度级；(e) 从新的亮度级中选择至少一个可用的第一亮度级；和(f) 使用第一亮度级检查图像的灰度是否改善，和/或如果灰度没有改善，则返回步骤(e)。根据该方法，可以增加图像的灰度的数量，并且使灰度的亮度水平之间的不规则差异规则，从而提高图像的质量。

$$\frac{|y_a - y_b|}{y_a} > y_{\text{delta}} \dots (1)$$