



(11) **EP 2 485 088 A2**

(12) **EUROPEAN PATENT APPLICATION**

(43) Date of publication:
08.08.2012 Bulletin 2012/32

(51) Int Cl.:
G02F 1/139^(2006.01) G02F 1/13363^(2006.01)

(21) Application number: **12154854.9**

(22) Date of filing: **27.01.2004**

(84) Designated Contracting States:
**AT BE BG CH CY CZ DE DK EE ES FI FR GB GR
HU IE IT LI LU MC NL PT RO SE SI SK TR**

(30) Priority: **28.01.2003 KR 20030005468**

(62) Document number(s) of the earlier application(s) in
accordance with Art. 76 EPC:
04705546.2 / 1 588 213

(71) Applicant: **LG Chem, Ltd.**
Seoul 150-721 (KR)

(72) Inventors:

- **Jeon, Byoung-kun**
305-740 Daejeon (KR)

- **Belyaev, Sergey**
305-740 Daejeon (KR)
- **Yu, Jeong Su**
305-345 Daejeon (KR)

(74) Representative: **HOFFMANN EITLE**
Patent- und Rechtsanwälte
Arabellastrasse 4
81925 München (DE)

Remarks:

This application was filed on 10-02-2012 as a
divisional application to the application mentioned
under INID code 62.

(54) **Vertically aligned liquid crystal display using a bi-axial retardation compensation film**

(57) Disclosed is a vertically aligned liquid crystal display ("VA-LCD") using a bi-axial retardation compensation film, capable of improving viewing angle characteristics.

EP 2 485 088 A2

Description**TECHNICAL FIELD**

5 [0001] The present invention relates to a vertically aligned liquid crystal display (hereinafter, referred to as a "VA-LCD") using a bi-axial retardation compensation film, capable of improving viewing angle characteristics.

BACKGROUND ART

10 [0002] As well known to those skilled in the art, a -C-plate compensation film and an A-plate compensation film have been used to compensate for a black state of a VA-LCD under the condition that small drive voltage is applied. U.S. Patent Serial No. 4,889,412 discloses a conventional VA-LCD using the -C-plate compensation film.

[0003] However, the conventional VA-LCD using the -C-plate compensation film does not completely compensate for a black state, thus having a disadvantage such as a leakage of light at a viewing angle.

15 [0004] Further, U.S. Patent Serial No. 6,141,075 discloses a conventional VA-LCD comprising both the -C-plate compensation film and the A-plate compensation film.

[0005] The above VA-LCD comprising both the -C-plate compensation film and the A-plate compensation film more completely achieves compensation of a black state under the condition that small drive voltage is applied.

20 [0006] However, the above-described conventional VA-LCDs require improvements of contrast and coloring at a front surface and a tilt angle in order to completely compensate for the black state.

DISCLOSURE OF THE INVENTION

25 [0007] Therefore, the present invention has been made in view of the above problems, and it is an object of the present invention to provide an achromatic VA-LCD in which contrast at a front surface and a tilt angle of the VA-LCD filled with liquid crystal having a positive or negative dielectric anisotropy is improved, and coloring at the tilt angle in a black state is minimized, thus improving of viewing angle characteristics.

30 [0008] In order to accomplish the above object, the present invention use a bi-axial retardation compensation film satisfying $n_x > n_y > n_z$, $R_{in} = (n_x - n_y) \times d > 0$ and $R_{th} = (n_z - n_y) \times d < 0$, wherein n_x and n_y are in-plane refractive indexes, n_z is a thickness refractive index, R_{in} is a in-plane retardation, R_{th} is a thickness retardation and d is a thickness.

[0009] The bi-axial retardation compensation film has a wavelength dispersion ($R_{in,400}/R_{in,550}$) in the range of 0.4~0.9 at wavelengths of 400nm and 550nm, and a wavelength dispersion ($R_{in,700}/R_{in,550}$) in the range of 1.1~1.8 at wavelengths of 700nm and 550nm.

35 [0010] An in-plane retardation (R_{in}) of the bi-axial retardation compensation film is in the range of 30~150nm at a wavelength of 550nm.

[0011] The bi-axial retardation compensation film has a wavelength dispersion ($R_{th,400}/R_{th,550}$) in the range of 1.05~1.4 at wavelengths of 400nm and 550nm, and a wavelength dispersion ($R_{th,700}/R_{th,550}$) in the range of 0.5~0.95 at wavelengths of 700nm and 550nm.

[0012] A thickness retardation (R_{th}) of the bi-axial retardation compensation film is in the range of -50~-500nm at 550nm.

40 [0013] The bi-axial retardation compensation film can be manufactured by elongating a polymer prepared with copolymerization of a first monomer and a second monomer, wherein the first monomer has a characteristic positive of a double refraction and the second monomer has a characteristic negative of a double refraction.

[0014] The bi-axial retardation compensation film can be manufactured by elongating a polymer prepared by mixing a first monomer and a second monomer, wherein the first monomer has a characteristic positive of a double refraction and the second monomer has a characteristic negative of a double refraction.

45 [0015] The bi-axial retardation compensation film can be prepared by laminating more than two sheets having different dependability of a in-plane retardation (R_{in}) and a thickness retardation (R_{th}).

50 [0016] Also in a vertically aligned LCD (VA-LCD) using a multi-domain mode or a chiral additive, provided with a bi-axial retardation compensation film, in which a vertically aligned panel is formed by injecting liquid crystal having a negative dielectric anisotropy ($\Delta\epsilon < 0$) or a positive dielectric anisotropy ($\Delta\epsilon > 0$) into a gap between upper and lower glass substrates, and upper and lower polarizing plates are arranged above the upper and lower surfaces of the VA-panel so that optical absorption axes of the polarizing plates are perpendicular to each other with the VA-panel as the central figure, and a cell gap in the range of $3\mu\text{m}$ to $8\mu\text{m}$ is maintained, a liquid crystal cell is prepared by arranging a bi-axial retardation compensation film between the vertically aligned panel and a upper and lower polarizing plate in which a in-plane refraction index (n_x, n_y) and a thickness refraction index (n_z) of the bi-axial retardation compensation film is $n_x > n_y > n_z$.

55 [0017] And an optical axis of the bi-axial retardation compensation film is arranged to be perpendicular to an absorption axis of an adjacent polarizing plate, and the bi-axial retardation compensation film has a reversed wavelength dispersion in which a in-plane retardation is increased in proportion to the increase of a wavelength in the range of visible rays, and

has a normal wavelength dispersion in which an absolute value of the thickness retardation is decreased in proportion to the increase of a wavelength in the range of visible rays.

[0018] In Example 1 of a vertically aligned LCD in accordance with the present invention, a liquid crystal cell is prepared by arranging the bi-axial retardation compensation film at one place of between the vertically aligned panel and upper polarizing plate, or between the vertically aligned panel and lower polarizing plate.

[0019] In Example 2 of a vertically aligned LCD in accordance with the present invention, a liquid crystal cell is prepared by arranging one of the individual bi-axial retardation compensation films between the vertically aligned panel and upper polarizing plate, or between the vertically aligned panel and lower polarizing plate.

[0020] In particular, the total of a thickness retardation including the vertically aligned panel and the bi-axial retardation compensation film being applied in the vertically aligned LCD is in the range of 30~150nm in proportion of a wavelength in the range of visible rays.

[0021] Also, in each of the above examples according to the present invention, directors of liquid crystalline polymers of the VA-panel, under the condition that no voltage is applied to the VA-panel, may have a pretilt angle in the range of 75° to 90° between the upper and lower glass substrates. The pretilt angle is preferably in the range of 87° to 90°, more preferably in the range of 89° to 90°.

[0022] Also, in each of the above examples according to the present invention, a liquid crystalline layer formed on the VA-panel may have a retardation in the range of 80nm to 400nm, preferably 80nm to 300nm, at a wavelength of 550nm.

[0023] A rubbed director of the liquid crystals of the VA-panel, under the condition that voltage is applied to the VA-panel, has an angle of 45° with the optical absorption axes of the polarizing plates.

BRIEF DESCRIPTION OF THE DRAWINGS

[0024] The above and other objects, features and other advantages of the present invention will be more clearly understood from the following detailed description taken in conjunction with the accompanying drawings, in which:

Fig. 1 is a perspective view of a VA-LCD cell comprising a bi-axial retardation compensation film in accordance with Example 1 according to the present invention;

Fig. 2 is a perspective view of a VA-LCD cell comprising a bi-axial retardation compensation film in accordance with Example 2 according to the present invention;

Fig. 3 is a reference view of a refraction index of a bi-axial retardation compensation film according to the present invention;

Fig. 4 is a graph showing a dependability of a wavelength dispersion of thickness retardation and a wavelength dispersion of a in-plain retardation of a bi-axial retardation compensation film applied in the present invention.

Fig. 5 is graphs showing the results of simulation for

(a) a transmittance according to a visual angle in a black state of the VA-LCD applying a bi-axial retardation compensation film according to the present invention, and

(b) a transmittance according to a visual angle in a black state of the VA-LCD applying a conventional bi-axial retardation compensation film.

Fig. 6 is diagrams showing the results of simulation for (a) a color variation in a black state of the VA-LCD applying a bi-axial retardation compensation film according to the present invention, and (b) a color variation in a black state of the VA-LCD applying a conventional retardation compensation film.

Fig. 7 is graphs showing the results of simulation for

(a) a transmittance in a black state according to a wavelength of the VA-LCD applying a bi-axial retardation compensation film according to the present invention, and

(b) a transmittance in a black state according to a wavelength of the VA-LCD applying a conventional bi-axial retardation compensation film.

Fig. 8 is a diagram showing the result of simulation of a contrast ratio for a structure of the VA-LCD of Example 1 at a tilt angle in the range of all azimuth angles, when applying a white ray.

Fig. 9 is a diagram showing the result of simulation of a contrast ratio for a structure of the VA-LCD, which is a modified example of Example 1, at a tilt angle in the range of 0°~80° at all azimuth angles, when applying a white ray.

Fig. 10 is a graph showing the result of simulation for a color variation in a black state of a structure of the VA-LCD, which is modified example of Example 1, at a tilt angle in the range of 0°~80°, which is varied by an interval of 2°, at azimuth angle of 45°, when applying a white ray.

Fig. 11 is a diagram showing the result of simulation for a contrast ratio of a structure of the VA-LCD of Example 2

at a tilt angle in the range of $0^\circ \sim 80^\circ$ at all azimuth angles, when applying a white ray.

Fig. 12 is a graph showing the result of simulation for a color variation in a black state of a structure of the VA-LCD of Example 2, at a tilt angle in the range of $0^\circ \sim 80^\circ$, which is varied by an interval of 2° , at azimuth angle of 45° , when applying a white ray.

5

BEST MODE FOR CARRYING OUT THE INVENTION

[0025] Now, preferred embodiments of the present invention will be described in detail with reference to the annexed drawings.

10 **[0026]** Figs. 1a, 1b and 2 illustrate respective examples of the VA-LCD in accordance with the present invention, wherein a VA-LCD cell is prepared by arranging bi-axial retardation compensation films 14, 14a, 14b between two polarizing plates 11, 12 so that absorption axes are perpendicular to each other with the VA-panel 13 as the central figure. Here, the polarizing plates 11, 12 can be comprised of a TAC (triacetate cellulose) protection film having a characteristic thickness retardation or other protection film not having a thickness retardation.

15 **[0027]** Figs. 1a and 1b are a structure of a VA-LCD cell according to Example 1 which is prepared by arranging one of a bi-axial retardation compensation film 14 between two of upper and lower polarizing plates 11, 12 which are perpendicular to a vertically aligned panel 13 so that a cell gap of $3 \sim 8 \mu\text{m}$ is maintained.

20 **[0028]** Fig. 1a illustrates an essential form of Example 1, in which a bi-axial retardation compensation film 14 is arranged between a vertically aligned panel 13 and a lower polarizing plate 11, wherein an optical axis 14c of the bi-axial retardation compensation film 14 is placed to be perpendicular to the an absorption axis 11c of the lower polarizing plate 11.

[0029] Fig. 1b illustrates other modified example of Example 1, in which a bi-axial retardation compensation film 14 is arranged between a vertically aligned panel 13 and an upper polarizing plate 12, wherein an optical axis 14c of the bi-axial retardation compensation film 14 is placed to be perpendicular to the an absorption axis 12c of the upper polarizing plate 12.

25 **[0030]** Fig. 2 is a structure of a VA-LCD cell according to Example 2 which is prepared by arranging two of bi-axial retardation compensation films 14a, 14b between two of upper and lower polarizing plates 11, 12 which are perpendicular to a vertically aligned panel 13 so that a cell gap of $3 \sim 8 \mu\text{m}$ is maintained.

30 **[0031]** Fig. 2 illustrates a VA-LCD cell of Example 2 in which one of the bi-axial retardation compensation film 14a is placed between a vertically aligned panel 13 and a lower polarizing plate 11, and another bi-axial retardation compensation film 14b is placed between a vertically aligned panel 13 and an upper polarizing plate 12, wherein an optical axis 14c of the bi-axial retardation compensation film 14a, placed between the vertically aligned panel 13 and the lower polarizing plate 11, is arranged to be perpendicular to an absorption axis 11c of the lower polarizing plate 11, and an optical axis 14c of the bi-axial retardation compensation film 14b, placed between the vertically aligned panel 13 and the upper polarizing plate 12, is arranged to be perpendicular to an absorption axis 12c of the upper polarizing plate 12.

35 **[0032]** Fig. 3 shows a refraction index of a bi-axial retardation compensation film in accordance with the present invention.

[0033] As shown in Fig. 3, a bi-axial retardation compensation film 14 according to the present invention has a refraction index of $n_x > n_y > n_z$, wherein n_x and n_y are in-plane refractive indexes, n_z is a thickness refractive index.

[0034] The bi-axial retardation compensation film has the following important characteristics.

40 **[0035]** A in-plane retardation value ($R_{in} = d \times n_x - n_y$, wherein d is a thickness of film) of the bi-axial retardation compensation film has a reversed wavelength dispersion in which retardation is increased in proportion to the increase of a wavelength in the range of visible rays.

45 **[0036]** A thickness retardation value ($R_{th} = d \times (n_z - n_y)$, wherein d is a thickness of film) of the bi-axial retardation compensation film is negative value, and has a reversed wavelength dispersion in which retardation is increased in proportion to the increase of a wavelength in the range of visible rays.

[0037] Fig. 4 is a reference view showing a dependability of a retardation value according to a wavelength of a bi-axial retardation compensation film in accordance with the present invention, which shows a wavelength dispersion ($R_{th}, \lambda/R_{th, 550}$) of a thickness retardation of the bi-axial retardation compensation film, and a wavelength dispersion ($R_{in}, \lambda/R_{in, 550}$) of an in-plane retardation.

50 **[0038]** As shown in Fig. 4, in a bi-axial retardation compensation film according to the present invention, an appropriate wavelength dispersion of an in-plane retardation value should have a relative retardation ratio ($R_{in, 400}/R_{in, 550}$) in the range of $0.4 \sim 0.9$ at wavelengths of 400nm and 550nm, and a relative retardation ratio ($R_{in, 700}/R_{in, 550}$) in the range of $1.1 \sim 1.8$ at wavelengths of 700nm and 550nm, wherein $R_{in, 400}$ is an in-plane retardation at a wavelength of 400nm, and $R_{in, 550}$ is an in-plane retardation at a wavelength of 550nm, and $R_{in, 700}$ is an in-plane retardation at a wavelength of 700nm.

55 **[0039]** An appropriate range of in-plane retardation of the bi-axial retardation compensation film according to the present invention is in the range of $30 \sim 150 \text{nm}$ at a wavelength of 550nm.

[0040] Also, an appropriate wavelength dispersion of a thickness retardation of a bi-axial retardation compensation film according to the present invention should have a relative retardation ratio ($R_{th, 400}/R_{th, 550}$) in the range of $1.05 \sim 1.4$

at wavelengths of 400nm and 550nm, and a relative retardation ratio ($R_{th,700}/R_{th,550}$) in the range of 0.5~0.95 at wavelengths of 700nm and 550nm.

[0041] An appropriate range of the thickness retardation value ($F_{th}=d \times (n_z-n_y)$) is in the range of -50~550nm at a wavelength of 550nm.

[0042] Accordingly, in case of preparing a vertically aligned LCD shown in Figs. 1a, 1b and 2, by using a bi-axial retardation compensation film according to the present invention, a complete compensation in a dark state of the VA-LCD at a tilt angle is possible, and a color variation of a dark state, a bright state and a RGB color can be minimized.

[0043] Fig. 5 is the results of comparing (a) a transmittance according to a visual angle in a black state of the VA-LCD applying a bi-axial retardation compensation film according to the present invention with (b) a transmittance according to a visual angle in a black state of the VA-LCD applying a conventional bi-axial retardation compensation film. It can be known that the bi-axial retardation compensation film according to the present invention has an excellent compensation in a black state more than a conventional bi-axial retardation compensation film.

[0044] For reference, the conventional bi-axial retardation compensation film is a polycarbonate retardation film, and a wavelength dispersion ($R_{th,400}/R_{th,550}$)= $(R_{in,400}/R_{in,550})$ thereof is 1.15.

[0045] Fig. 6 is the results of comparing (a) a color variation in a black state of the VA-LCD applying a bi-axial retardation compensation film according to the present invention with (b) a color variation in a black state of the VA-LCD applying a conventional retardation compensation film. It can be known that a color variation in a black state of a bi-axial retardation compensation film of the present invention is much smaller than that of a conventional bi-axial retardation compensation film.

[0046] The reason for showing a low transmittance in a black state and a small color variation in a black state when employing a bi-axial retardation compensation film of the present invention is that a transmittance variation in accordance with a wavelength is flat.

[0047] A bi-axial retardation compensation film in accordance with the present invention can be prepared by laminating 2~3 of a conventional film having a different dependability of retardation to a wavelength.

[0048] Also, the bi-axial retardation compensation film can be manufactured by elongating a polymer prepared with co-polymerization of a first monomer and a second monomer, or by elongating a polymer prepared by mixing a first monomer and a second monomer, wherein the first monomer has a characteristic positive of a double refraction and the second monomer has a characteristic negative of a double refraction.

Example 1

[0049] A VA-LCD was prepared by arranging one of a bi-axial retardation compensation film 14 between a vertically aligned panel 13 and upper and lower polarizing plates 11, 12 which are perpendicular to each other so that a cell gap of 3~8 μm is maintained.

[0050] Fig. 1a illustrates an essential form of Example 1, in which a bi-axial retardation compensation film 14 is arranged between a vertically aligned panel 13 and a lower polarizing plate 1.1, wherein an optical axis 14c of the bi-axial retardation compensation film 14 is placed to be perpendicular to the an absorption axis 11c of the lower polarizing plate 11.

[0051] Fig. 1b illustrates other modified example of Example 1, in which a bi-axial retardation compensation film 14 is arranged between a vertically aligned panel 13 and an upper polarizing plate 12, wherein an optical axis 14c of the bi-axial retardation compensation film 14 is placed to be perpendicular to the an absorption axis 12c of the upper polarizing plate 12.

Example 2

[0052] A VA-LCD as shown in Fig. 2 was prepared by arranging two of bi-axial retardation compensation films 14a, 14b between two of upper and lower polarizing plates 11, 12 which are perpendicular to a vertically aligned panel 13 so that a cell gap of 3~8 μm is maintained.

[0053] Namely, two of bi-axial retardation compensation film was employed in this Example 2, in which one of the bi-axial retardation compensation film 14a is placed between a vertically aligned panel 13 and a lower polarizing plate 11, and another bi-axial retardation compensation film 14b is placed between a vertically aligned panel 13 and an upper polarizing plate 12, wherein an optical axis 14c of the bi-axial retardation compensation film 14a, placed between the vertically aligned panel 13 and the lower polarizing plate 11, is arranged to be perpendicular to an absorption axis 11c of the lower polarizing plate 11, and an optical axis 14c of the bi-axial retardation compensation film 14b, placed between the vertically aligned panel 13 and the upper polarizing plate 12, is arranged to be perpendicular to an absorption axis 12c of the upper polarizing plate 12.

[0054] Hereinafter, experimental examples for testing contrast characteristics of samples selected from the above examples of a VA-LCD employing a bi-axial retardation compensation film of the present invention will be described. Improvements of the contrast characteristics in the respective examples will be more easily understood by the below

experimental examples. The below experimental examples will be disclosed for illustrative purposes, but do not limit the subject matter of the present invention.

Experimental Example 1

[0055] A VA-LCD of Fig. 1(a) applying one of a bi-axial retardation compensation film prepared by Example 1 was used as a sample in this Experimental Example.

[0056] The VA-LCD included a VA-panel having a cell gap of $3\mu\text{m}$, wherein a pretilt angle was 89° , a dielectric anisotropy ($\Delta\epsilon$) was -4.9 , a refractive anisotropy (Δn) was 0.0979 , and a wavelength dispersion ($\Delta n_{400}/\Delta n_{550}$) was 1.096 . Accordingly, a thickness retardation ($R_{VA,550}$) of the VA-panel at a wavelength of 550nm was 297nm .

[0057] The bi-axial retardation compensation film was prepared with polycarbonate series, wherein a thickness retardation value ($R_{th}(550\text{nm})$) was -270nm , an in-plane retardation value ($R_{in}(550\text{nm})$) was 67nm , a wavelength dispersion of a thickness retardation ($R_{th}(450\text{nm})/R_{th}(550\text{nm})$) was 1.15 , and a wavelength dispersion of an in-plane retardation ($R_{in}(450\text{nm})/R_{in}(550\text{nm})$) was 0.652 .

[0058] Fig. 8 shows the result of simulation of a contrast ratio of the VA-LCD compensated by employing the above bi-axial retardation compensation film, and Fig. 6 shows a color variation in a black state of the VA-LCD compensated by employing the above bi-axial retardation compensation film,

Modified Example of (Experimental Example 1)

[0059] A VA-LCD of Fig. 1(b) applying one of a bi-axial retardation compensation film prepared by Example 1 was used as a sample in this Experimental Example.

[0060] The VA-LCD included a VA-panel having a cell gap of $3\mu\text{m}$, wherein a pretilt angle was 89° , a dielectric anisotropy ($\Delta\epsilon$) was -4.9 , a refractive anisotropy (Δn) was 0.0979 , and a wavelength dispersion ($\Delta n_{400}/\Delta n_{550}$) was 1.096 . Accordingly, a thickness retardation ($R_{VA,550}$) of the VA-panel at a wavelength of 550nm was 297nm .

[0061] The bi-axial retardation compensation film was prepared with triacetate cellulose (TAG) series, wherein a thickness retardation value ($R_{th}(550\text{nm})$) was -241nm , an in-plane retardation value ($R_{in}(550\text{nm})$) was 44nm , a wavelength dispersion of a thickness retardation ($R_{th}(450\text{nm})/R_{th}(550\text{nm})$) was 1.12 , and a wavelength dispersion of an in-plane retardation ($R_{in}(450\text{nm})/R_{in}(550\text{nm})$) was 0.61 .

[0062] Fig. 9 shows the result of simulation of a contrast ratio for a structure of the VA-ZCD, and also Fig. 10 shows the result of simulation for a color variation in a black state of a structure of the VA-LCD.

[0063] Table 1 comparatively shows contrasts of the sample (hereinafter, referred to as a 'first sample') employed by the Modified Example of Experimental Example 1 and a sample (hereinafter, referred to as a 'second sample') serving as a comparative example. Here, in the first sample, the retardation (R_{VA}) of the VA-panel at 550nm , the thickness retardation (R_{th}) of the bi-axial retardation film, the total retardation (R_{TOTAL}) of the two retardation (R_{VA}, R_{th}), and the in-plane retardation (R_{in}) of the bi-axial retardation film were 297 , -240 , $+46$ and 90 , respectively. On the other hand, in the second sample, the retardation (R_{VA}) of the VA-panel at 550nm , the thickness retardation (R_{th}) of the bi-axial retardation film, the total retardation (R_{TOTAL}) of the two retardation (R_{VA}, R_{th}), and the in-plane retardation (R_{in}) of the bi-axial retardation film were 297 , -100 , $+197$ and 0 , respectively. And the minimum contrasts of the first and second samples at a tilt angle of 70° were 160 and 5 , respectively.

Table 1

	R_{VA}	R_{th}	R_{TOTAL}	R_{in}	Minimum contrast (at a tilt angle of 70°)
First sample (Experimental Example)	297	-240	+46	395	160
Second sample (Comparative Example)	297	-100	+197	460	5

[0064] In Table 1, the minimum contrasts of the first and second samples at a tilt angle of 70° were 160 and 5 . Since the tilt angle of 70° has the minimum contrast, other tilt angles rather than the tilt angle of 70° have contrasts higher than the minimum contrast. Accordingly, the contrasts at other tilt angles rather than the tilt angle of 70° are higher than the minimum contrast.

(Experimental Example 2)

[0065] A VA-LCD of Fig. 2 applying two of a bi-axial retardation compensation film prepared by Example 2 was used as a sample in this Experimental Example.

[0066] The VA-LCD included a VA-panel having a cell gap of $3\mu\text{m}$, wherein a pretilt angle was 89° , a dielectric

anisotropy ($\Delta\epsilon$) was -4.9, a refractive anisotropy (Δn) was 0.0979, and a wavelength dispersion ($\Delta n_{400}/\Delta n_{550}$) was 1.096. Accordingly, a thickness retardation ($R_{VA,550}$) of the VA-panel at a wavelength of 550nm was 297nm.

[0067] The two of bi-axial retardation compensation films were prepared with polycarbonate series, wherein a thickness retardation value ($R_{th}(550nm)$) was -119nm, a in-plain retardation value ($R_{in}(550nm)$) was 44nm, a wavelength dispersion of a thickness retardation ($R_{th}(450nm)/R_{th}(550nm)$) was 1.24, and a wavelength dispersion of a in-plain retardation ($R_{in}(450nm)/R_{in}(550nm)$) was 0.585.

[0068] Fig. 11 shows the result of simulation of a contrast ratio for a structure of the VA-LCD, and also Fig. 12 shows the result of simulation for a color variation in a black state of a structure of the VA-LCD.

INDUSTRIAL APPLICABILITY

[0069] As apparent from the above description, the present invention provides a VA-LCD comprising a bi-axial retardation compensation film, which compensates for a dark state at a tilt angle of the VA-LCD and minimizes coloring in dark, white and RGB states, thus improving viewing angle characteristics.

[0070] Although the preferred embodiments of the present invention have been disclosed for illustrative purposes, those skilled in the art will appreciate that various modifications, additions and substitutions are possible, without departing from the scope and spirit of the invention as disclosed in the accompanying claims.

[0071] The present invention can also be summarised by the following embodiments (embs):

Emb. 1. A bi-axial retardation compensation film having $n_x > n_y > n_z$, $R_{in} = (n_x - n_y) \times d > 0$ and $R_{th} = (n_z - n_y) \times d < 0$, wherein n_x and n_y are in-plain refractive indexes, n_z is a thickness refractive index, R_{in} is a in-plain retardation, R_{th} is a thickness retardation and d is a thickness.

Emb.2. The bi-axial retardation compensation film according to Emb 1, wherein a wavelength dispersion ($R_{in,400}/R_{in,550}$) is in the range of 0.4~0.9 at wavelengths of 400nm and 550nm, and a wavelength dispersion ($R_{in,700}/R_{in,550}$) is in the range of 1.1~2.8 at wavelengths of 700nm and 550nm, wherein $R_{in,400}$, $R_{in,550}$ and $R_{in,700}$ are in-plain retardations at wavelengths of 400nm, 550nm and 700nm.

Emb. 3. The bi-axial retardation compensation film according to Emb 1, wherein a in-plain retardation (R_{in}) is in the range of 30~150nm at a wavelength of 550nm.

Emb. 4. The bi-axial retardation compensation film according to Emb 1, wherein a wavelength dispersion ($R_{th,400}/R_{th,550}$) is in the range of 1.05~1.4 at wavelengths of 400nm and 550nm, and a wavelength dispersion ($R_{th,700}/R_{th,550}$) is in the range of 0.5~0.95 at wavelengths of 700nm and 550nm, wherein $R_{th,400}$, $R_{th,550}$ and $R_{th,700}$ are thickness retardations at wavelengths of 400nm, 550nm and 700nm.

Emb. 5. The bi-axial retardation compensation film according to Emb 1, wherein a thickness retardation (R_{th}) is in the range of -50~500nm at 550nm.

Emb. 6. The bi-axial retardation compensation film according to Emb 1, wherein said bi-axial retardation compensation film is manufactured by elongating a polymer prepared with co-polymerization of a first monomer and a second monomer, wherein the first monomer has a characteristic positive of a double refraction and the second monomer has a characteristic negative of a double refraction.

Emb. 7. The bi-axial retardation compensation film according to Emb 1, wherein said bi-axial retardation compensation film is manufactured by elongating a polymer prepared by mixing a first monomer and a second monomer, wherein the first monomer has a characteristic positive of a double refraction and the second monomer has a characteristic negative of a double refraction.

Emb. 8. The bi-axial retardation compensation film according to Emb 1, wherein said bi-axial retardation compensation film is prepared by laminating more than two sheets having different dependability of a in-plane retardation (R_{in}) and a thickness retardation (R_{th}).

Emb 9. In a vertically aligned LCD (VA-LCD) using a multi-domain mode or a chiral additive, provided with a bi-axial retardation compensation film, in which a vertically aligned panel is formed by injecting liquid crystal having a negative dielectric anisotropy ($\Delta\epsilon < 0$) or a positive dielectric anisotropy ($\Delta\epsilon > 0$) into a gap between upper and lower glass substrates, and upper and lower polarizing plates are arranged above the upper and lower surfaces of the VA-panel so that optical absorption axes of the polarizing plates are perpendicular to each other with the VA-panel as the

central figure, and a cell gap in the range of $3\mu\text{m}$ to $8\mu\text{m}$ is maintained,
 a liquid crystal cell is prepared by arranging a bi-axial retardation compensation film between the vertically aligned panel and a upper and lower polarizing plate in which a in-plain refraction index (n_x , n_y) and a thickness refraction index (n_z) of the bi-axial retardation compensation film is $n_x > n_y > n_z$; and
 5 an optical axis of the bi-axial retardation compensation film is arranged to be perpendicular to an absorption axis of an adjacent polarizing plate, and the bi-axial retardation compensation film has a reversed wavelength dispersion in which a in-plain retardation is increased in proportion to the increase of a wavelength in the range of visible rays, and has a normal wavelength dispersion in which an absolute value of the thickness retardation is decreased in proportion to the increase of a wavelength in the range of visible rays.

10 Emb. 10. The vertically aligned LCD according to Emb 2, wherein a liquid crystal cell is prepared by arranging the bi-axial retardation compensation film at one place of between the vertically aligned panel and upper polarizing plate, or between the vertically aligned panel and lower polarizing plate.

15 Emb. 11. The vertically aligned LCD according to Emb 9, wherein a liquid crystal cell is prepared by arranging one of the individual bi-axial retardation compensation films between the vertically aligned panel and upper polarizing plate, and between the vertically aligned panel and lower polarizing plate.

20 Emb. 12. The vertically aligned LCD according to Emb 9, wherein the total of a thickness retardation including the vertically aligned panel and the bi-axial retardation compensation film being applied in the vertically aligned LCD is in the range of 30~150nm in proportion of a wavelength in the range of visible rays.

25 Emb. 13. The vertically aligned LCD according to Emb 12, wherein directors of liquid crystalline polymers of the VIA-panel, under the condition that no voltage is applied to the VA-panel, may have a pretilt angle in the range of 75 to 90° between the upper and lower glass substrates.

Emb. 14. The vertically aligned LCD according to Emb 13, wherein the pretilt angle is in the range of 87° to 90°.

30 Emb. 15. The vertically aligned LCD according to Emb 13, wherein the pretilt angle is in the range of 89° to 90°.

Emb. 16. The vertically aligned LCD according to Emb 12, wherein a liquid crystalline layer of the VA-panel has a retardation in the range of 80nm to 400nm at a wavelength of 550nm.

35 Emb. 17. The vertically aligned LCD according to Emb 16, wherein a liquid crystalline layer of the VA-panel has a retardation in the range of 80nm to 300nm at a wavelength of 550nm.

40 Emb. 18. The vertically aligned LCD according to Emb 12, wherein a rubbed director of the liquid crystals of the VA-panel, under the condition that voltage is applied to the VA-panel, has an angle of 45° with the optical absorption axes of the polarizing plate.

Claims

- 45 1. In a vertically aligned LCD (VA-LCD) using a multi-domain mode or a chiral additive, provided with a bi-axial retardation compensation film, in which a vertically aligned panel is formed by injecting liquid crystal having a negative dielectric anisotropy ($\Delta\epsilon < 0$) or a positive dielectric anisotropy ($\Delta\epsilon > 0$) into a gap between upper and lower glass substrates, and upper and lower polarizing plates are arranged above the upper and lower surfaces of the VA-panel so that optical absorption axes of the polarizing plates are perpendicular to each other with the VA-panel as the central figure, and a cell gap in the range of $3\mu\text{m}$ to $8\mu\text{m}$ is maintained,
 50 a liquid crystal cell is prepared by arranging a bi-axial retardation compensation film between the vertically aligned panel and a upper and lower polarizing plate in which a in-plain refraction index (n_x , n_y) and a thickness refraction index (n_z) of the bi-axial retardation compensation film is $n_x > n_y > n_z$; and
 an optical axis of the bi-axial retardation compensation film is arranged to be perpendicular to an absorption axis of an adjacent polarizing plate, and the bi-axial retardation compensation film has a reversed wavelength dispersion in which a in-plain retardation is increased in proportion to the increase of a wavelength in the range of visible rays, and has a normal wavelength dispersion in which an absolute value of the thickness retardation is decreased in proportion to the increase of a wavelength in the range of visible rays.

EP 2 485 088 A2

2. The vertically aligned LCD according to claim 1, wherein a liquid crystal cell is prepared by arranging one of the individual bi-axial retardation compensation films between the vertically aligned panel and upper polarizing plate, and between the vertically aligned panel and lower polarizing plate.
- 5 3. The vertically aligned LCD according to claim 1, wherein the total of a thickness retardation including the vertically aligned panel and the bi-axial retardation compensation film being applied in the vertically aligned LCD is in the range of 30~150nm in proportion of a wavelength in the range of visible rays.
- 10 4. The vertically aligned LCD according to claim 3 wherein directors of liquid crystalline polymers of the VA-panel, under the condition that no voltage is applied to the VA-panel, may have a pretilt angle in the range of 75° to 90° between the upper and lower glass substrates.
5. The vertically aligned LCD according to claim 4, wherein the pretilt angle is in the range of 87° to 90°.
- 15 6. The vertically aligned LCD according to claim 4, wherein the pretilt angle is in the range of 89° to 90°.
7. The vertically aligned LCD according to claim 3, wherein a liquid crystalline layer of the VA-panel has a retardation in the range of 80nm to 400nm at a wavelength of 550nm.
- 20 8. The vertically aligned LCD according to claim 7, wherein a liquid crystallize layer of the VA-panel has a retardation in the range of 80nm to 300nm at a wavelength of 55 nm.
- 25 9. The vertically aligned LCD according to claim 3, wherein a rubbed director of the liquid crystals of the VA-panel, under the condition that voltage is applied to the VA-panel, has an angle of 45° with the optical absorption axes of the polarizing plate.

30

35

40

45

50

55

FIGURE 1

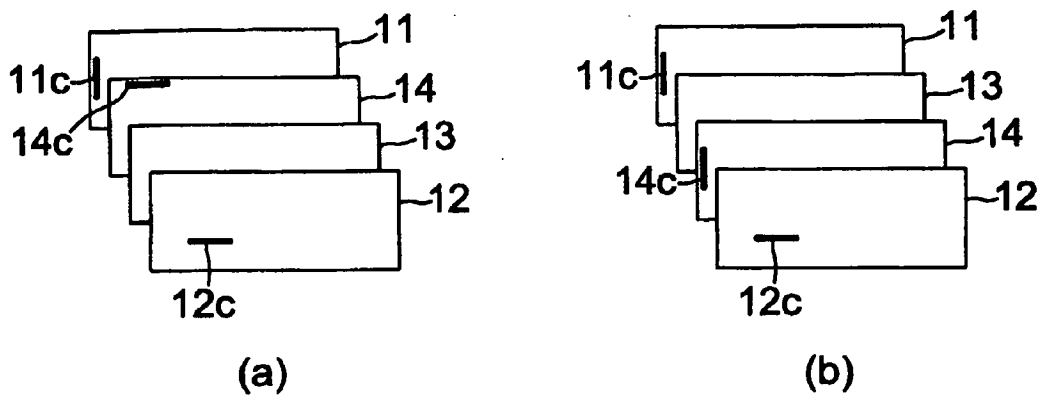

FIGURE 2

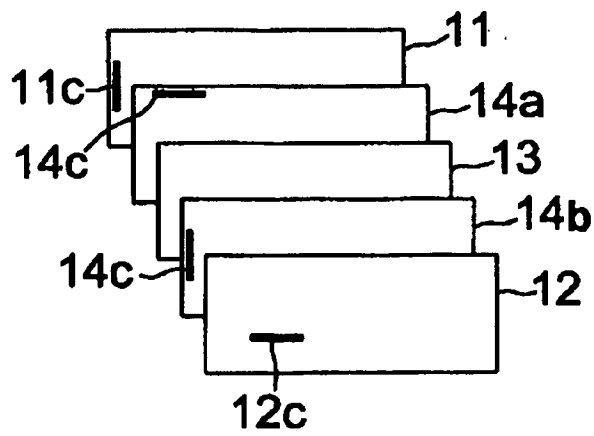

FIGURE 3

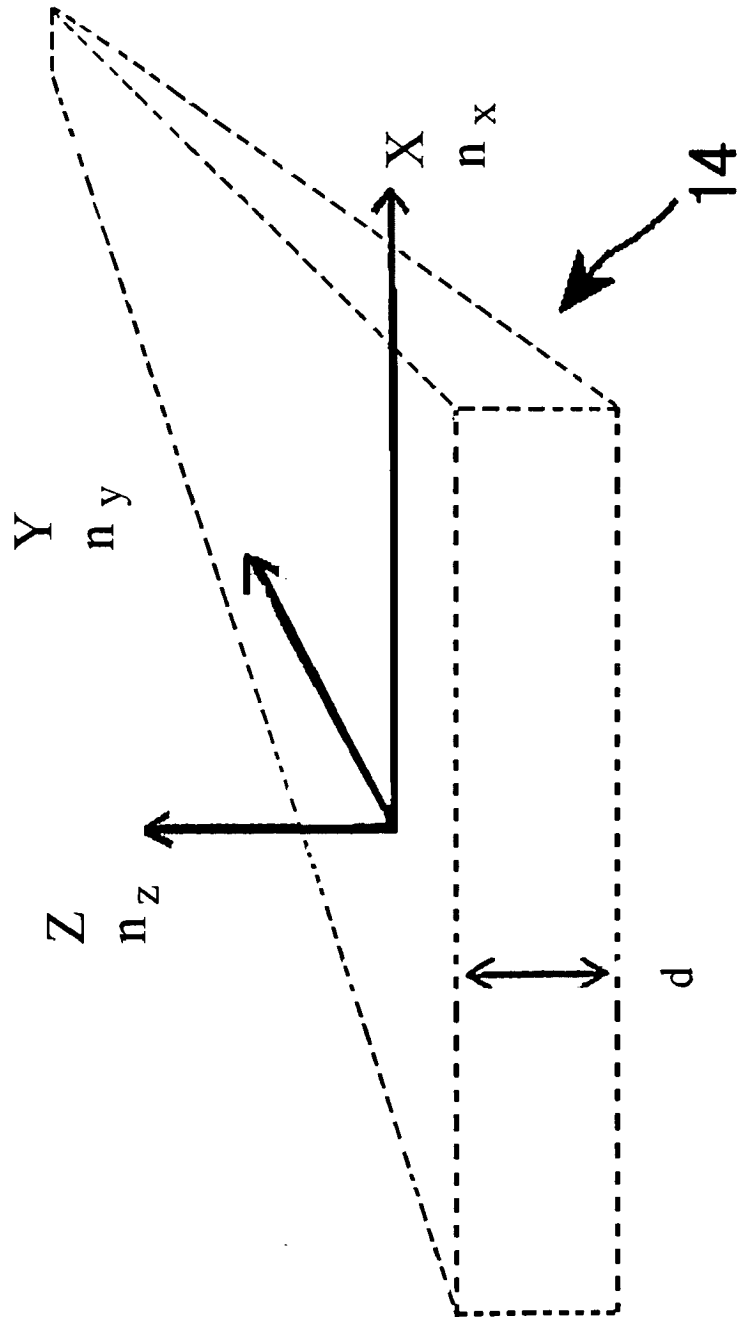

FIGURE 4

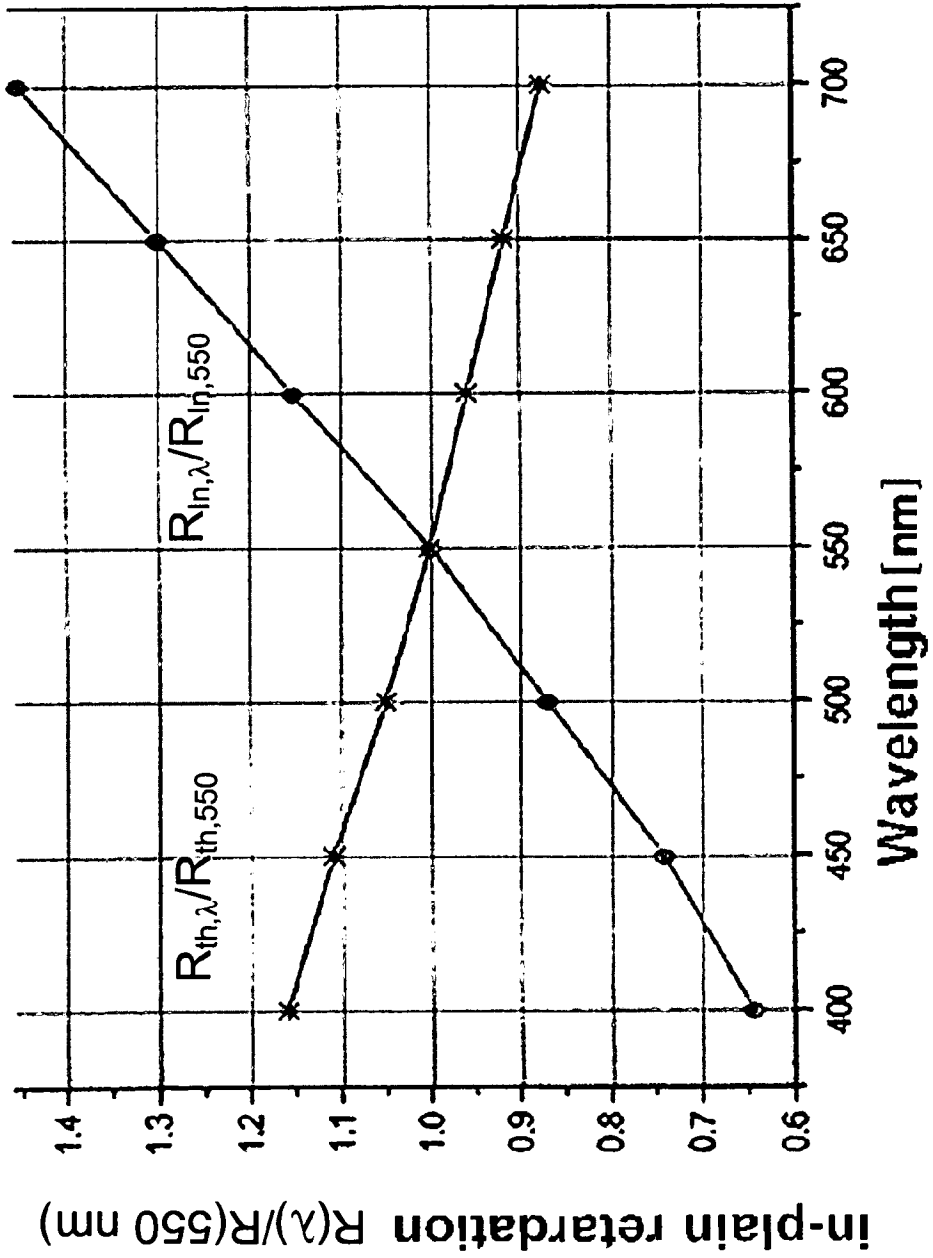
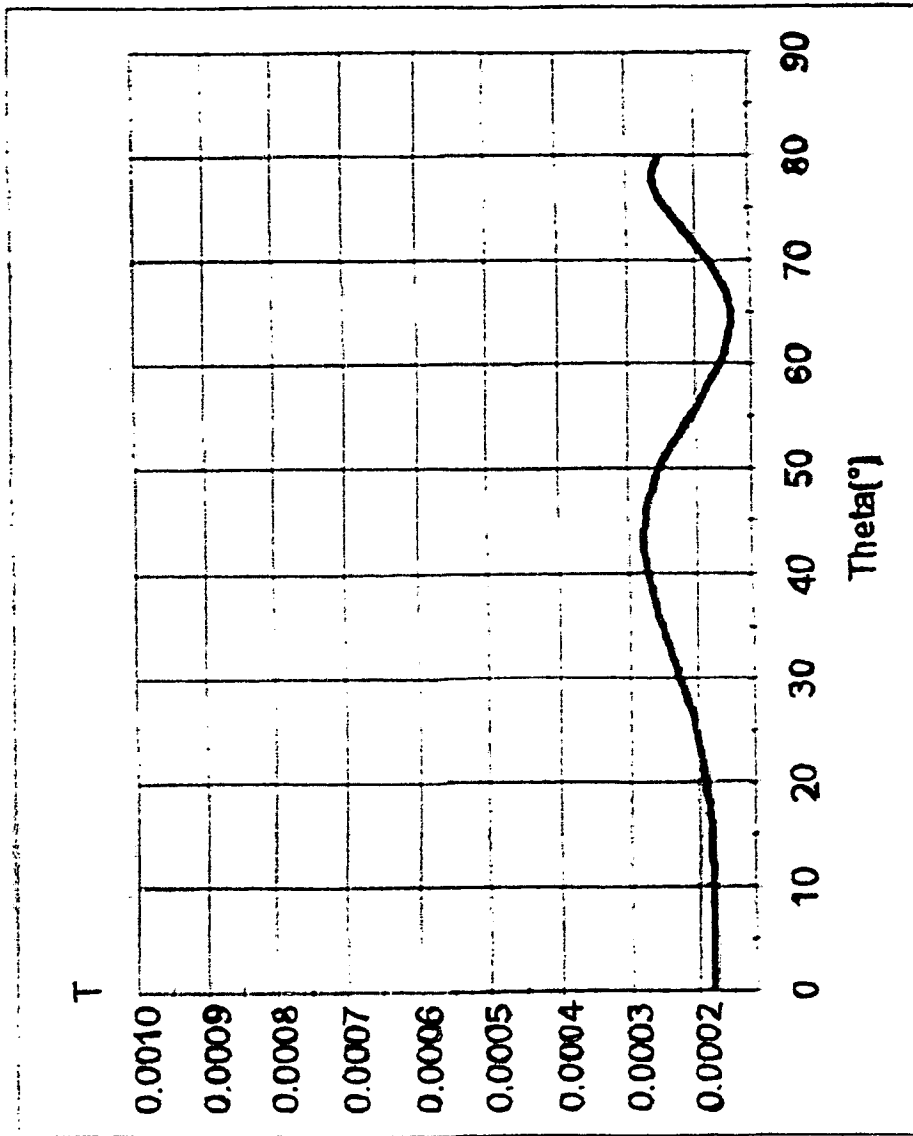
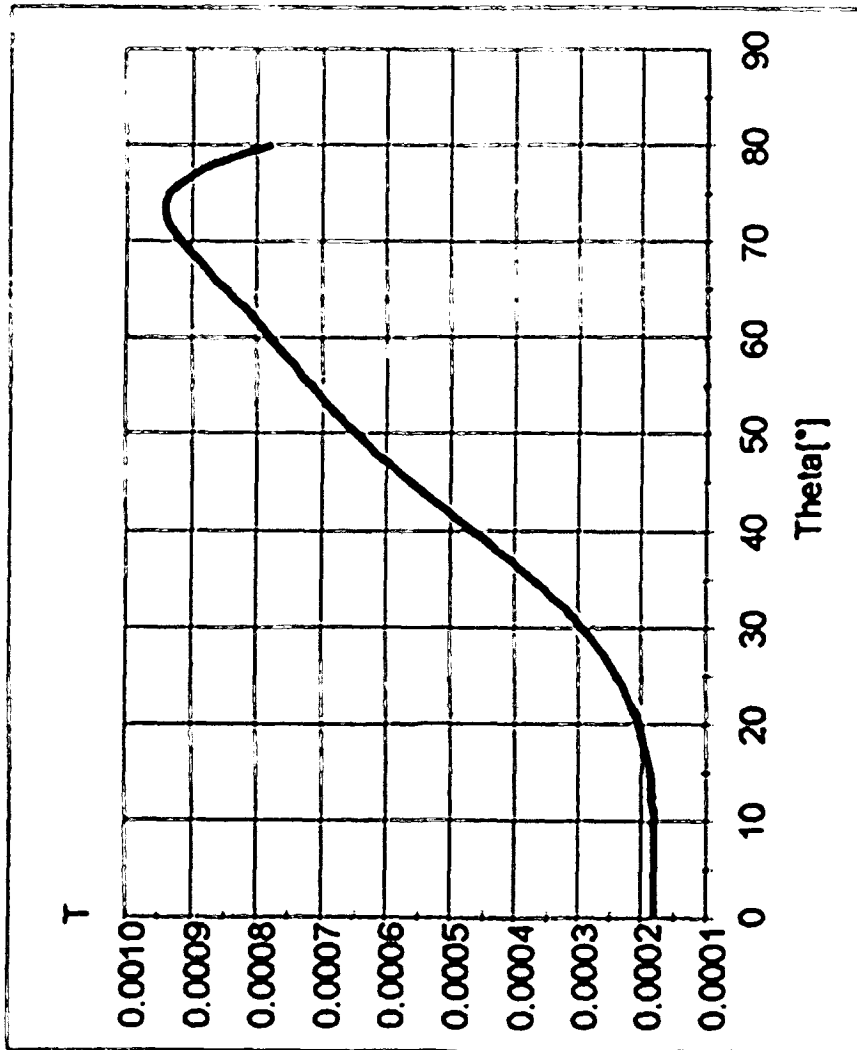

FIGURE 5a



(a)

FIGURE 5b



(b)

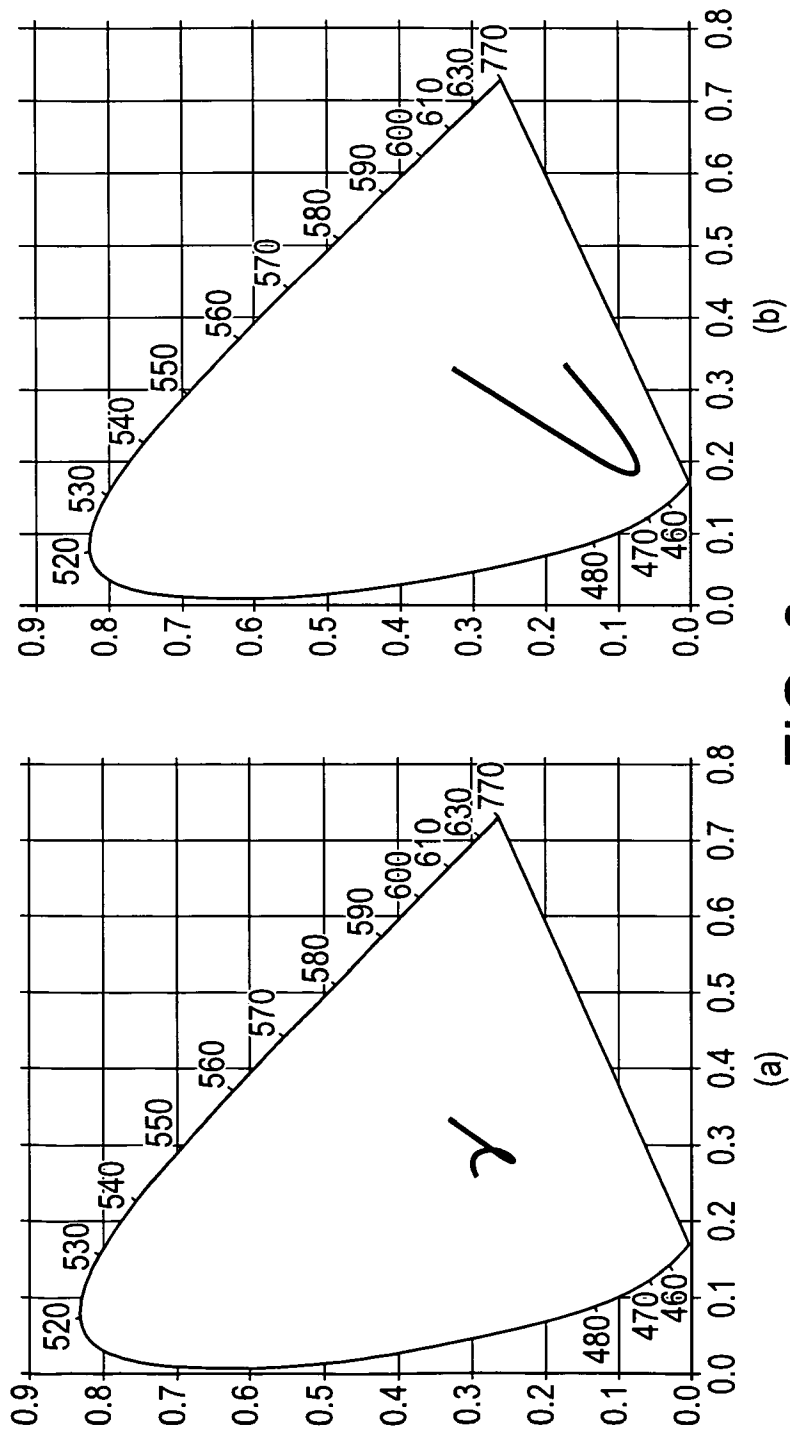

FIG. 6

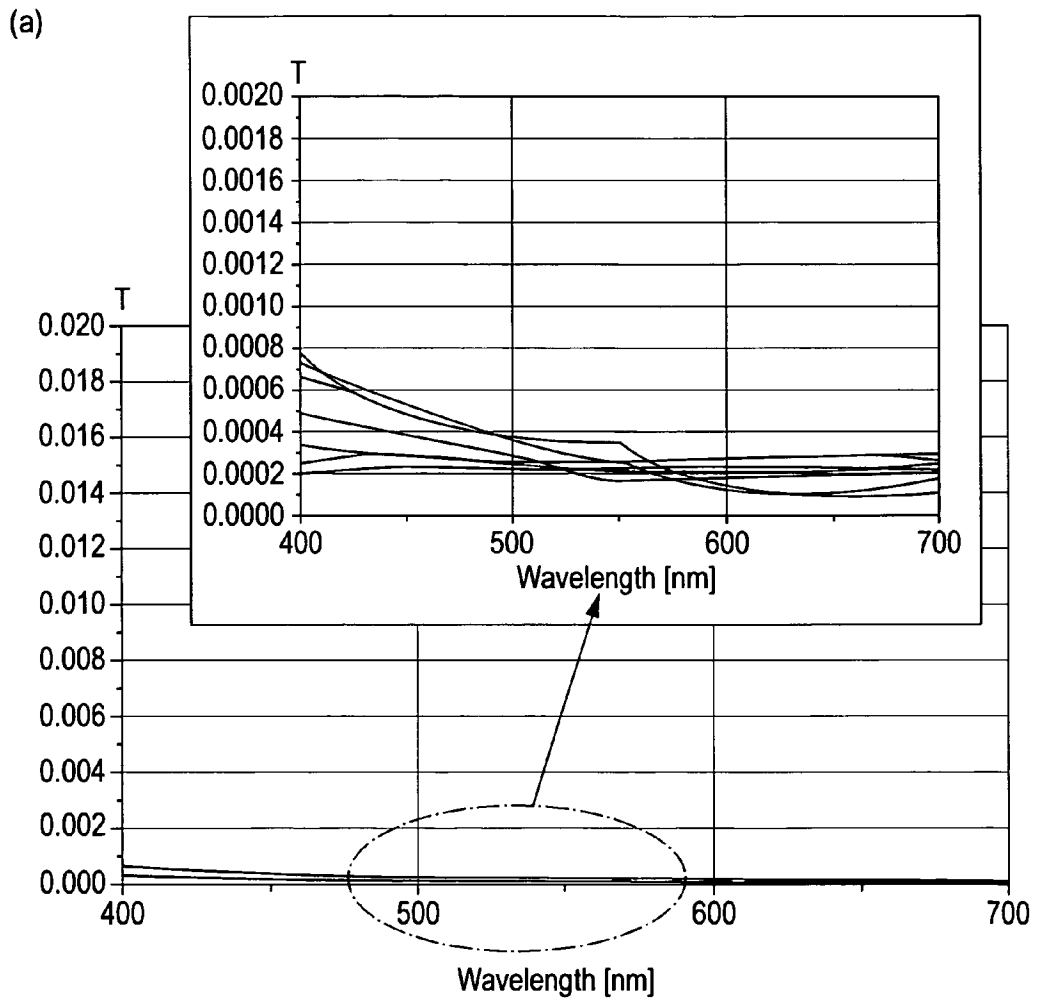

FIG. 7

(b)

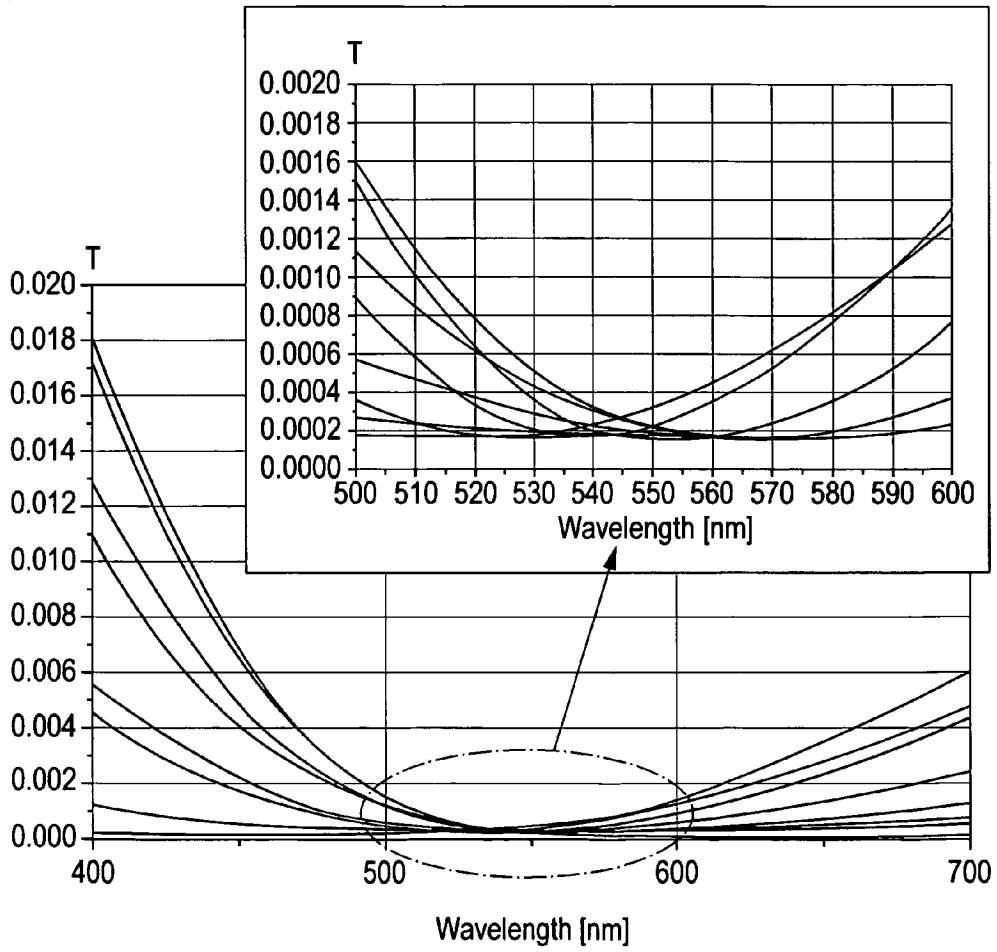

FIG. 7 Cont'd

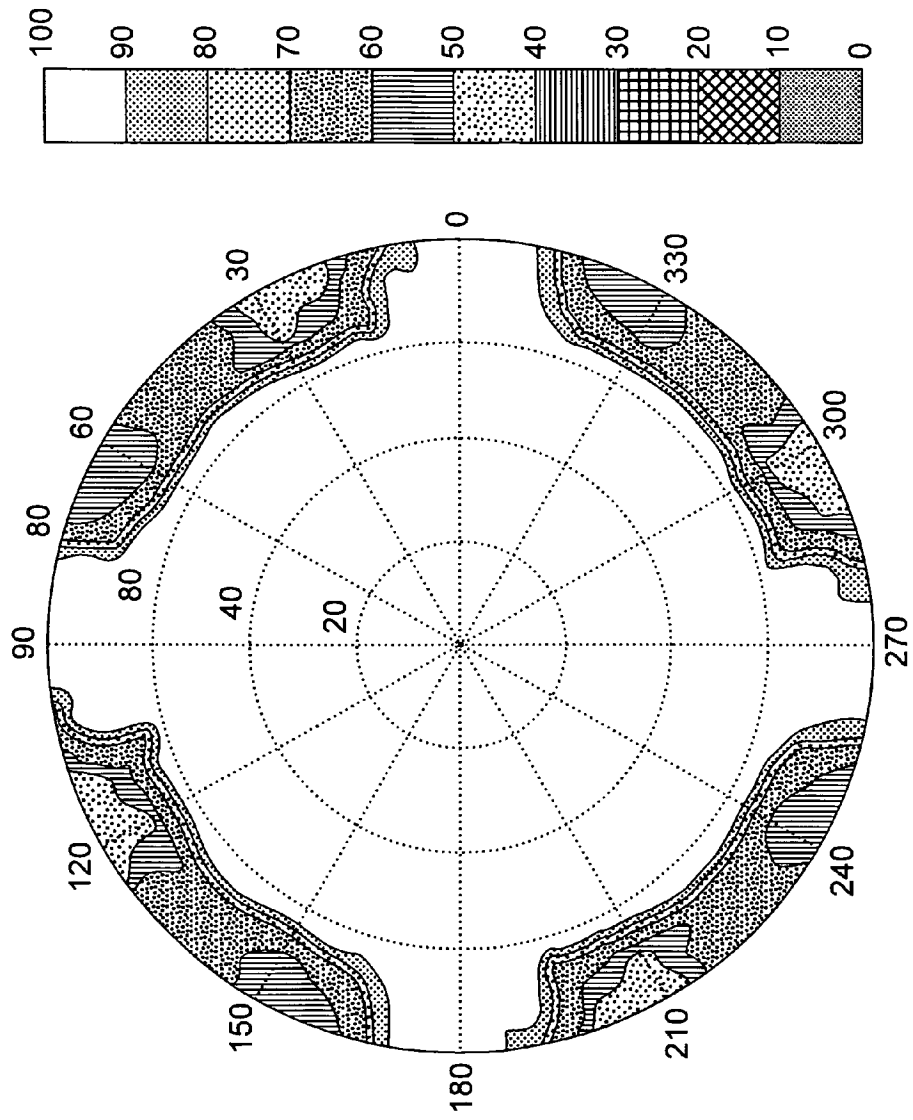

FIG. 8

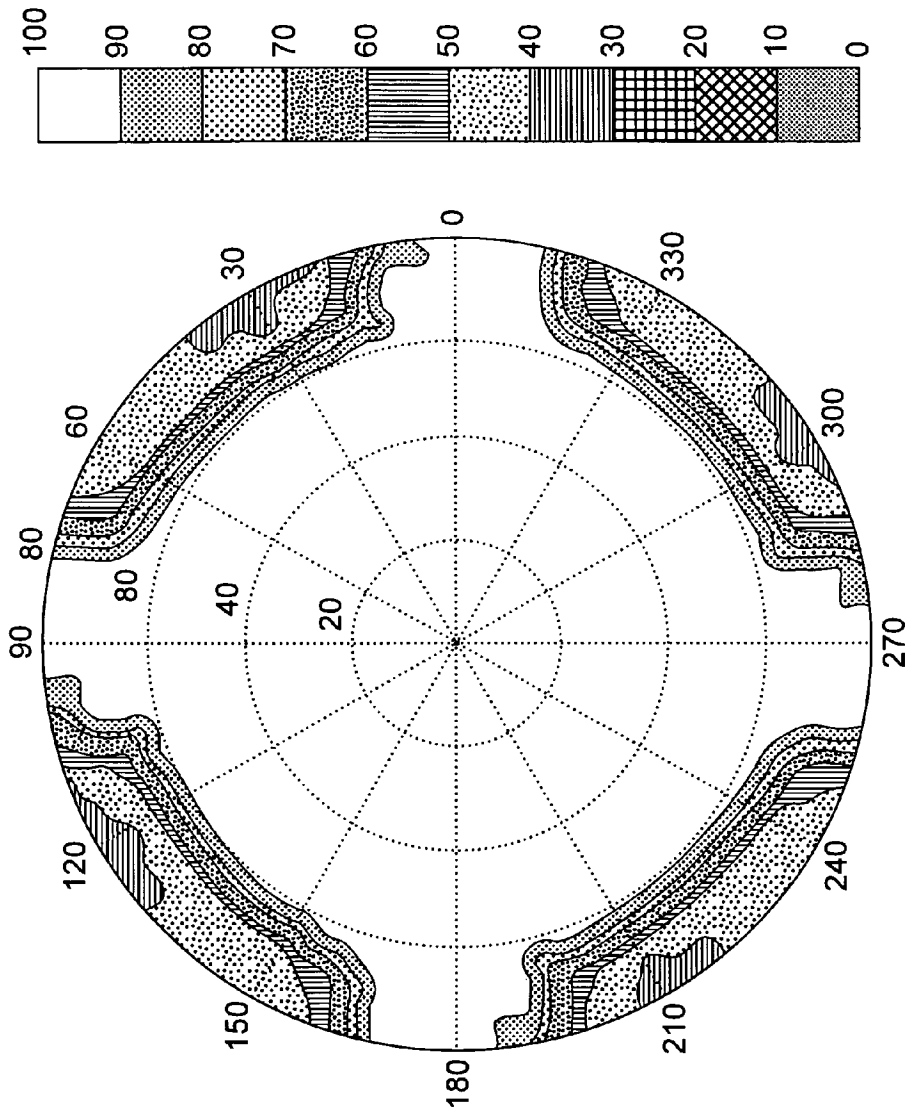
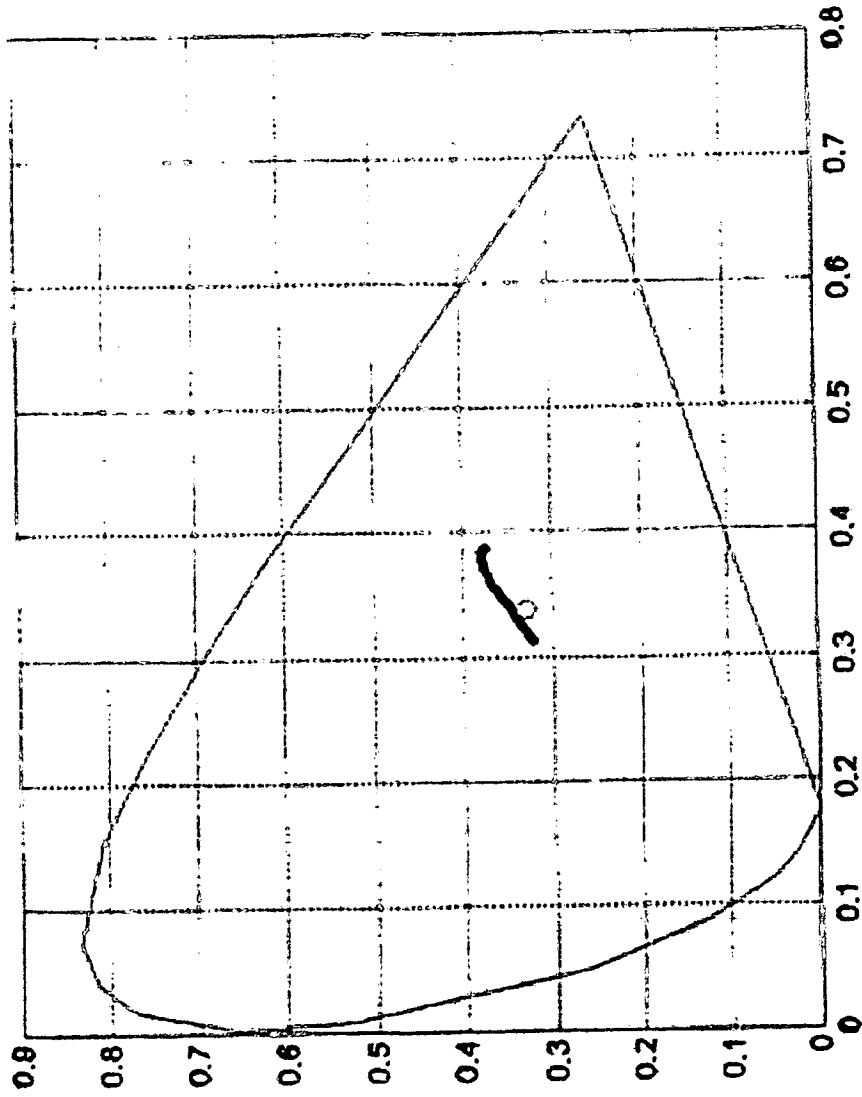

FIG. 9

FIGURE 10



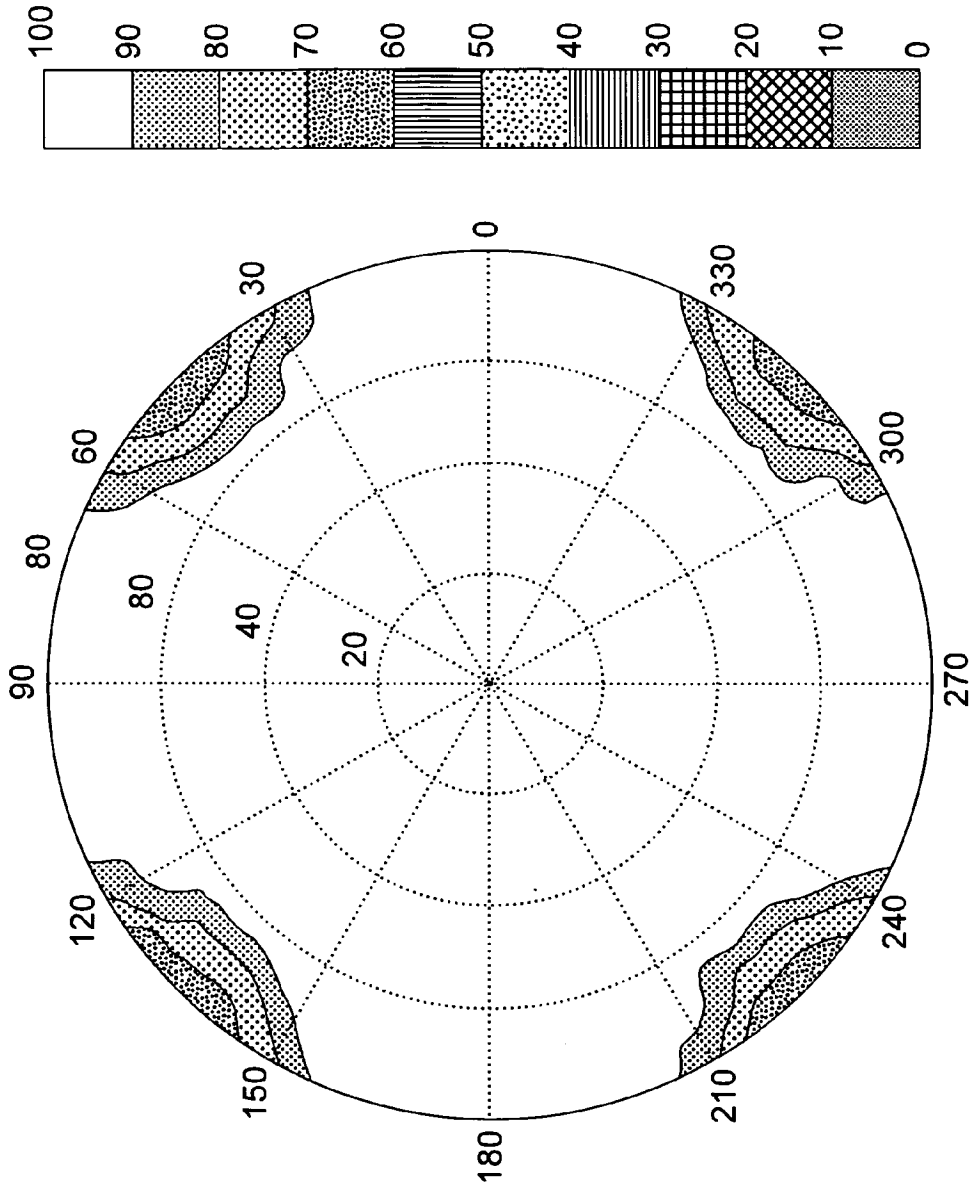
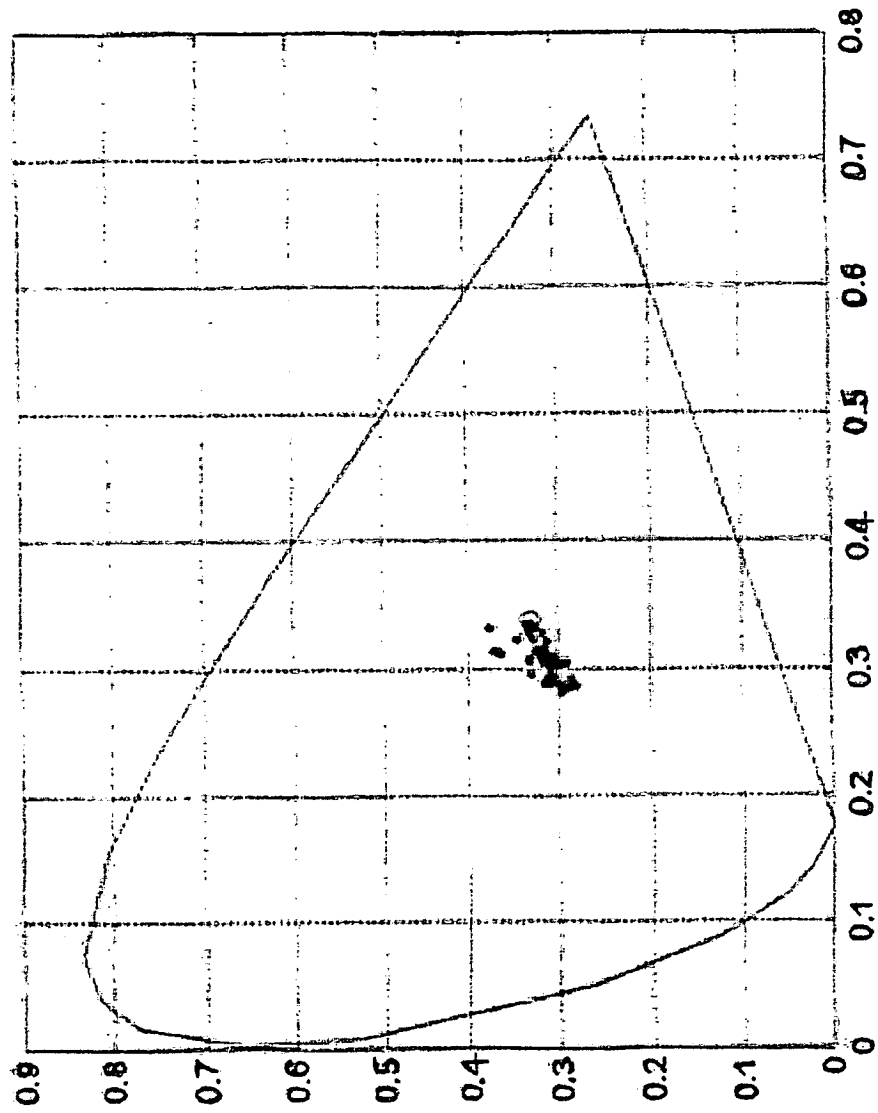

FIG. 11

FIGURE 12



REFERENCES CITED IN THE DESCRIPTION

This list of references cited by the applicant is for the reader's convenience only. It does not form part of the European patent document. Even though great care has been taken in compiling the references, errors or omissions cannot be excluded and the EPO disclaims all liability in this regard.

Patent documents cited in the description

- US 4889412 A [0002]
- US 6141075 A [0004]

专利名称(译)	使用双轴延迟补偿膜的垂直排列的液晶显示器		
公开(公告)号	EP2485088A2	公开(公告)日	2012-08-08
申请号	EP2012154854	申请日	2004-01-27
[标]申请(专利权)人(译)	乐金化学股份有限公司		
申请(专利权)人(译)	LG化学有限公司.		
当前申请(专利权)人(译)	LG化学有限公司.		
[标]发明人	JEON BYOUNG KUN BELYAEV SERGEY YU JEONG SU		
发明人	JEON, BYOUNG-KUN BELYAEV, SERGEY YU, JEONG SU		
IPC分类号	G02F1/139 G02F1/13363		
CPC分类号	G02F1/133634 G02F1/1393 G02F2001/133637		
优先权	1020030005468 2003-01-28 KR PCT/KR2004/000133 2004-01-27 WO		
其他公开文献	EP2485088A3 EP2485088B1		
外部链接	Espacenet		

摘要(译)

公开了一种使用双轴延迟补偿膜的垂直排列的液晶显示器 (“VA-LCD”)，其能够改善视角特性。

