

(19)



(11)

**EP 1 994 442 B1**

(12)

**EUROPEAN PATENT SPECIFICATION**

(45) Date of publication and mention of the grant of the patent:  
**30.12.2015 Bulletin 2015/53**

(51) Int Cl.:  
**G02F 1/1339 (2006.01)**

(21) Application number: **07737741.4**

(86) International application number:  
**PCT/JP2007/054130**

(22) Date of filing: **27.02.2007**

(87) International publication number:  
**WO 2007/100123 (07.09.2007 Gazette 2007/36)**

(54) **LIQUID CRYSTAL DISPLAY APPARATUS COMPRISING SPACERS**

FLÜSSIGKRISTALLANZEIGEVORRICHTUNG MIT ABSTANDHALTERN

DISPOSITIF D’AFFICHAGE A CRISTAUX LIQUIDES COMPRENANT DES ESPACEURS

(84) Designated Contracting States:  
**DE FR GB**

(72) Inventor: **YANAGISAWA, Masaki**  
**Tokyo 205-8555 (JP)**

(30) Priority: **28.02.2006 JP 2006051633**

(74) Representative: **Grünecker Patent- und  
Rechtsanwälte  
PartG mbB  
Leopoldstraße 4  
80802 München (DE)**

(43) Date of publication of application:  
**26.11.2008 Bulletin 2008/48**

(73) Proprietor: **CASIO COMPUTER CO., LTD.**  
**Shibuya-ku,**  
**Tokyo 151-8543 (JP)**

(56) References cited:  
**JP-A- 2004 271 886      JP-A- 2005 017 494**  
**US-A1- 2004 169 797      US-A1- 2005 237 469**

**EP 1 994 442 B1**

Note: Within nine months of the publication of the mention of the grant of the European patent in the European Patent Bulletin, any person may give notice to the European Patent Office of opposition to that patent, in accordance with the Implementing Regulations. Notice of opposition shall not be deemed to have been filed until the opposition fee has been paid. (Art. 99(1) European Patent Convention).

**Description**

## Technical Field

**[0001]** The present invention relates to a liquid crystal display apparatus having spacers between the substrates of the liquid crystal display apparatus, according to the preamble of claim 1. Such a device is known from JP 2005 017 494.

## Background Art

**[0002]** In a conventional liquid crystal display apparatus described in Jpn. Pat. Appln. KOKAI Publication No. 2002-214621, R (red), G (green), and B (blue) pixel regions are arranged in stripes, and columnar spacers are arranged in non-pixel regions arranged between the R pixel regions and B pixel regions respectively located upstream and downstream in the direction of rubbing treatment. This prevents an alignment defect resulting from the columnar spacers from occurring in the G pixel region, which has a visual sensitivity that is higher than visual sensitivities of the R pixel region and B pixel region. As a result, a display nonuniformity due to the alignment defect resulting from the columnar spacers will not be observed easily.

**[0003]** In the conventional liquid crystal display apparatus described above, columnar spacers are arranged regularly in the non-pixel regions between the R pixel regions and B pixel regions respectively located upstream and downstream in the direction of rubbing treatment. Namely, the columnar spacers are arranged in all the non-pixel regions downstream of all the R pixel regions in the direction of rubbing treatment. The columnar spacers are thus arranged consecutively with respect to the R pixel regions located in the direction of rubbing treatment. With this structure, an alignment defect resulting from the consecutively arranged columnar spacers is observed as a display abnormality on a straight line extending in the direction of rubbing treatment.

## Disclosure of Invention

**[0004]** An object of the present invention is to provide a liquid crystal display apparatus in which an alignment defect resulting from the spacers will not be easily observed as a display abnormality on a straight line extending in the direction of rubbing treatment. Such an object is achieved by a liquid crystal display apparatus according to claim 1.

**[0005]** According to the present invention, the spacers are arranged intermittently along the direction of rubbing treatment. As a result, an alignment defect resulting from the spacers will not be easily observed as a display abnormality on the straight line extending in the direction of rubbing treatment.

## Brief Description of Drawings

**[0006]**

FIG. 1 is a sectional view showing the main part of a liquid crystal display apparatus according to an embodiment of the present invention;

FIG. 2 shows a planar arrangement relationship among some color filter elements, some pixel electrodes, and some columnar spacers; and

FIG. 3 shows a planar arrangement relationship between some pixel electrodes and some columnar spacers.

**15 Best Mode for Carrying Out the Invention**

**[0007]** FIG. 1 is a sectional view showing the main part of a liquid crystal display apparatus according to an embodiment of the present invention. This liquid crystal display apparatus is of an active matrix type and includes a first substrate, i.e., an active substrate 1, and a second substrate, i.e., a countersubstrate 11. The active substrate 1 and countersubstrate 11 are formed by glass substrates. Thin film transistors 2 serving as switching elements are formed in a matrix on the upper surface (an inner surface opposing the countersubstrate 11) of the active substrate 1.

**[0008]** An overcoat film 3 is formed on the upper surface of the active substrate 1 and on the thin film transistors 2. Red-, green-, and blue-display pixel electrodes 4R, 4G, and 4B are formed on the upper surface of the overcoat film 3. The pixel electrodes 4R, 4G, and 4B are respectively connected to corresponding thin film transistors 2 through contact holes 5 formed in the overcoat film 3. An alignment film 6 is formed on the upper surface of the overcoat film 3 and on the pixel electrodes 4R, 4G, and 4B.

**[0009]** The end of the drain electrode of each thin film transistor 2 is arranged on one end side of an operational semiconductor layer, made of amorphous silicon (a-Si) or the like, on a gate electrode. The source electrode of each thin film transistor 2 is formed so that the end thereof is arranged on the other end side of the semiconductor layer. The source electrode connects to a pixel electrode 4R, 4G, or 4B through a corresponding contact hole 5.

**[0010]** Light-shielding films 12 and red, green, and blue color filter elements 13R, 13G, and 13B are formed on the lower surface (an inner surface opposing the active substrate 1) of the countersubstrate 11. A counterelectrode, i.e., a common electrode 14, is formed to cover the lower surfaces of the color filter elements 13R, 13B, and 13B. Columnar spacers 15 are arranged at predetermined portions of the lower surface of the common electrode 14 between the color filter elements 13R and 13G. An alignment film 16 is formed on the lower surface of the common electrode 14 and on the surfaces (i.e., lower and side surfaces as shown in FIG. 1) of the columnar spacers 15. In this case, the columnar spacers

15 and the alignment film 16 formed on the surfaces of the columnar spacers 15 constitute a practical columnar spacer.

**[0011]** The active substrate 1 and countersubstrate 11 adhere to each other via an almost square frame-shaped seal member (not shown) interposed between them. In this state, the lower surface of the practical columnar spacer is in contact with the upper surface of the alignment film 6 of the active substrate 1. The active substrate 1 and countersubstrate 11 are arranged to oppose each other with an almost constant gap therebetween, with the alignment films 6 and 16 provided inside of the gap between the active substrate 1 and countersubstrate 11. The alignment films 6 and 16 of the two substrates 1 and 11 seal a liquid crystal 17 inside the seal member.

**[0012]** FIG. 2 shows a planar arrangement relationship among some color filter elements 13R, 13G, and 13B, some pixel electrodes 4R, 4G, and 4B, and some columnar spacers 15. The color filter elements 13R, 13G, and 13B extend in a column direction of the liquid crystal display (a direction along which columns of pixels of the display extend) and are arranged in stripes. The vertically elongated pixel electrodes 4R, 4G, and 4B are arranged under the color filter elements 13R, 13G, and 13B at the same pitch in the column direction.

**[0013]** Display regions of the liquid crystal display apparatus are formed by regions where the pixel electrodes 4R, 4G, and 4B and color filter elements 13R, 13G, and 13B overlap, excluding regions where the light-shielding film 12 and thin film transistors 2 are provided. The remaining region, e.g., a portion among the pixel electrodes 4R, 4G, and 4B, forms a substantially grid-like non-display region. The pixel electrodes 4R, 4G, and 4B arranged close to each other in the row direction of the liquid crystal display apparatus (the direction along which rows of pixels of the liquid crystal display apparatus extend). Three pixel electrodes 4R, 4G, 4B, (i.e., one each of red, green and blue) form one pixel. The columnar spacers 15 are arranged in the non-display regions on the upper left of the green-display pixel electrodes 4G as viewed from the top (i.e., when looking down at the upper, or outer, surface of the countersubstrate 11). However, the columnar spacers 15 are absent in some cases, as will be described hereinafter.

**[0014]** FIG. 3 shows a planar arrangement relationship between some pixel electrodes 4R, 4G, and 4B and some columnar spacers 15. Referring to FIG. 3, the vertically elongated rectangular regions defined by (surrounded by) vertical lines and horizontal lines indicate the pixel electrodes 4R, 4G, and 4B. The black dots formed on the upper left corners of specific green-display pixel electrodes 4G indicate the columnar spacers 15.

**[0015]** Referring to FIG. 3, the pixel electrodes 4R, 4G, and 4B for respectively displaying red, green, and blue are arranged in stripes. The pixel electrodes 4R, 4G, and 4B constitute pixels arranged in a matrix. Each pixel includes three pixel electrodes 4R, 4G, and 4B arranged close to each other in the row direction. Each pixel has

a substantially (or almost) square shape. The number of columnar spacers 15 is smaller than the number of pixels.

**[0016]** The columnar spacers 15 indicated by the black dots in FIG. 3 are arranged arbitrarily in a random manner. In the example shown in FIG. 3, among the pixels of the 1st column, the columnar spacers 15 are arranged at the upper left corners of the pixel electrodes 4G in the 1st, 2nd, 4th, 5th, 6th, and 9th rows. Among the pixels of the 2nd column, the columnar spacers 15 are arranged at the upper left corners of the pixel electrodes 4G in the 2nd, 3rd, 4th, 7th, 11th, and 12th rows. Among the pixels of the 3rd column, the columnar spacers 15 are arranged at the upper left corners of the pixel electrodes 4G in the 1st, 5th, 6th, 8th, 9th, and 10th rows. Among the pixels of the 4th column, the columnar spacers 15 are arranged at the upper left corners of the pixel electrodes 4G in the 3rd, 4th, 6th, 7th, 8th, and 11th rows. Among the pixels of the 5th column, the columnar spacers 15 are arranged at the upper left corners of the pixel electrodes 4G in the 1st, 2nd, 5th, 9th, 10th, and 12th rows. And in the 6th column shown in FIG. 3, the columnar spacers 15 are arranged at the upper left corners of the pixel electrodes 4G of the 3rd, 7th, 8th, 10th, 11th, and 12th rows.

**[0017]** The arrows running from the upper right to the lower left of FIG. 3 indicate the direction of rubbing treatment, as seen from the upper surface side of the countersubstrate 11, with respect to the alignment film 16 of the countersubstrate 11 shown in FIG. 1. A direction of rubbing treatment for the alignment film of the second substrate is parallel to a diagonal of each pixel. Along the direction of rubbing treatment indicated by the arrows in FIG. 3, at least one columnar spacer 15 is present per three consecutive pixels, although one or less columnar spacer 15 is provided per pixel, and the columnar spacers 15 are arranged such that no three consecutive pixels along the direction of the rubbing treatment all have a respective columnar spacer corresponding thereto. In other words, the columnar spacers 15 are arranged so that, along the direction of rubbing treatment indicated by the arrows, not more than one spacer is provided per pixel, at least one spacer is present per three consecutive pixels, and no three consecutive pixels along the direction of the rubbing treatment all have a respective columnar spacer corresponding thereto. That is, not more than one columnar spacer is provided per pixel, and at least one, but not more than two, columnar spacers are provided per three consecutive pixels along the direction of the rubbing treatment.

**[0018]** As a result, the columnar spacers 15 are intermittently arranged along the direction of rubbing treatment. This prevents an alignment defect resulting from the columnar spacers 15 from being easily observed as a display abnormality on a straight line extending in the direction of rubbing treatment.

**[0019]** In the row direction, at least one columnar spacer 15 is present per three consecutive pixels, although one or less columnar spacer 15 is provided per pixel, and the columnar spacers 15 are arranged such that no three

consecutive pixels along the row direction all have a respective columnar spacer corresponding thereto. In other words, along the row direction, the columnar spacers 15 are arranged so that not more than one spacer is provided per pixel, at least one spacer is present per three consecutive pixels, and no three consecutive pixels along the row direction all have a respective columnar spacer corresponding thereto. That is, not more than one columnar spacer is provided per pixel, and at least one, but not more than two, columnar spacers are provided per three consecutive pixels along the row direction.

**[0020]** In the column direction, at least one columnar spacer 15 is present per four consecutive pixels, although one or less columnar spacer 15 is provided per pixel, and the columnar spacers 15 are arranged such that no four consecutive pixels along the column direction all have a respective columnar spacer corresponding thereto. In other words, along the column direction, the columnar spacers 15 are arranged so that not more than one spacer is provided per pixel, at least one spacer is present per four consecutive pixels, and no four consecutive pixels along the column direction all have a respective columnar spacer corresponding thereto. That is, not more than one columnar spacer is provided per pixel, and at least one, but not more than three, columnar spacers are provided per four consecutive pixels along the column direction.

**[0021]** This arrangement of columnar spacers along the row and column directions further prevents an aligning defect resulting from the columnar spacers 15 from being easily observed as a display abnormality on a straight line extending in the direction of rubbing treatment. In this case, the columnar spacers 15 are consecutively arranged on up to three pixels in the direction of column and not on four or more pixels, because a display abnormality due to an aligning defect resulting from the columnar spacers 15 does not stand out in the direction of column.

**[0022]** As shown in FIG. 3, a rectangular region including six pixels in the row direction and 12 pixels in the column direction is defined as a reference region. Predetermined numbers of such reference regions are arranged in the row direction and the column direction to constitute the entire pixel region of one liquid crystal display apparatus. In this case, the number of columnar spacers 15 arranged in each column in the reference region shown in FIG. 3 is six, which is half the number of pixels in each column in the reference region, and the number of columnar spacers 15 arranged in each row in the reference region shown in FIG. 3 is three, which is half the number of pixels in each row in the reference region. Accordingly, the number of spacers arranged in each column in the reference region is the same, and the number of spacers arranged in each row in the reference region is the same. Thus, in the reference region, even if the columnar spacers 15 are arranged arbitrarily in a random manner, they are arranged almost uniformly, to ensure uniform thickness of the liquid crystal layer.

**[0023]** In the above embodiment, as shown in FIG. 2, the columnar spacers 15 are arranged in the upper left non-display regions of the green-display pixel electrodes 4G. However, the present invention is not limited to this.

5 The columnar spacers 15 may be arranged in the upper left non-display regions of the red-display pixel electrodes 4R, or the upper left non-display regions of the blue-display pixel electrodes 4B. Also, the columnar spacers 15 may be arranged at arbitrary random positions of the non-display regions of the pixel electrodes 4R, 4G, and 4B, irrespective of what color corresponds to the pixel electrode.

**[0024]** In the above embodiment, the present invention is applied to an active matrix type color liquid crystal display apparatus. However, the present invention is not limited to this, and can also be applied to a simple matrix type color liquid crystal display apparatus, or a monochrome active matrix type or simple matrix type liquid crystal display apparatus.

20 **[0025]** In the above embodiment, along the row direction, the spacers 15 are arranged so that not more than one spacer is provided per pixel, at least one spacer is present per three consecutive pixels, and no three consecutive pixels along the row direction all have a respective columnar spacer corresponding thereto. However, the present invention is not limited to this. Along the row direction, the spacers 15 may be arranged so that not more than one spacer is provided per pixel, at least one spacer is present per three consecutive pixels, and no two consecutive pixels along the row direction both have a respective columnar spacer corresponding thereto.

30 **[0026]** In the above embodiment, along the column direction, the spacers 15 are arranged so that not more than one spacer is provided per pixel, at least one spacer is present per four consecutive pixels, and no four consecutive pixels along the column direction all have a respective columnar spacer corresponding thereto. However, the present invention is not limited to this. Along the column direction, the spacers 15 may be arranged so that not more than one spacer is provided per pixel, at least one spacer is present per three consecutive pixels, and no three consecutive pixels along the column direction all have a respective columnar spacer corresponding thereto. Alternatively, along the column direction, the spacers 15 may be arranged so that not more than one spacer is provided per pixel, at least one spacer is present per three consecutive pixels, and no two consecutive pixels along the column direction both have a respective columnar spacer corresponding thereto.

## Claims

1. A liquid crystal display apparatus comprising:

- a first substrate (1) provided with a first alignment film (6) on one surface thereof;
- a second substrate (11) arranged to face the

- surface of the first substrate on which the first alignment film is provided, and provided with a second alignment film (16) on one surface thereof that faces the first substrate;
- a plurality of spacers (15) formed on the second substrate and keeping a distance between the first substrate and the second substrate; and
- a plurality of pixels arranged in a row direction and a column direction, and respectively having a plurality of pixel electrodes (4R, 4G, 4B) or a plurality of color filters (13R, 13G, 13B) that respectively correspond to different color components,
- the number of spacers being smaller than the number of the pixels,
- each pixel being provided with at most one spacer, and
- the second alignment film having been subjected to rubbing treatment in a direction of a first diagonal of each pixel,
- characterized in that**
- in a series of pixels arranged in the direction of the first diagonal along a direction of the rubbing treatment, not more than one columnar spacer is provided per pixel, and at least one, but not more than two, columnar spacers are provided per three consecutive pixels.
2. The liquid crystal display apparatus according to claim 1, **characterized in that** in the series of pixels arranged in the direction of the first diagonal, two consecutive pixels are provided with spacers.
  3. The liquid crystal display apparatus according to claim 2, **characterized in that** in the series of pixels arranged in the direction of the first diagonal, two consecutive pixels respectively provided with spacers and two consecutive pixels not provided with spacers are arranged alternately.
  4. The liquid crystal display apparatus according to claim 1, **characterized in that** in a series of pixels arranged in the row direction, at least one and at most two of three consecutive pixels are each provided with a spacer.
  5. The liquid crystal display apparatus according to claim 4, **characterized in that** in a series of pixels arranged in the column direction, at least one and at most three of four consecutive pixels are each provided with a spacer.
  6. The liquid crystal display apparatus according to any one of claims 1 to 5, **characterized in that** the different color components are arranged in stripes.
  7. The liquid crystal display apparatus according to any one of claims 1 to 6, **characterized in that** the dif-

ferent color components are red, green, and blue color components; and the spacers are formed in regions corresponding to the green components.

8. The liquid crystal display apparatus according to any one of claims 1 to 7, **characterized in that** the spacers comprise columnar spacers.
9. The liquid crystal display apparatus according to any one of claims 1 to 8, **characterized in that** the number of spacers is half of the number of pixels.
10. The liquid crystal display apparatus according to any one of claims 1 to 9, **characterized in that** the second alignment film covers the spacers.
11. The liquid crystal display apparatus according to any one of claims 1 to 10, **characterized in that** the spacers are arranged in the same positions of the respective pixels provided with the spacers.

#### Patentansprüche

1. Flüssigkristall-Anzeigevorrichtung, die umfasst:
  - ein erstes Substrat (1), das mit einer ersten Alignment-Schicht (6) an einer Fläche desselben versehen ist;
  - ein zweites Substrat (11), das so angeordnet ist, dass es der Fläche des ersten Substrats zugewandt ist, an der die erste Alignment-Schicht vorhanden ist, und mit einer zweiten Alignment-Schicht (16) an einer Fläche desselben versehen ist, die dem ersten Substrat zugewandt ist;
  - eine Vielzahl von Abstandshaltern (15), die an dem zweiten Substrat ausgebildet sind und einen Abstand zwischen dem ersten Substrat und dem zweiten Substrat aufrechterhalten; und
  - eine Vielzahl von Pixeln, die in einer Zeilen-Richtung und einer Spalten-Richtung angeordnet sind und jeweils eine Vielzahl von Pixel-Elektroden (4R, 4G, 4B) oder eine Vielzahl von Farbfiltern (13R, 13G, 13B) aufweisen, die jeweils unterschiedlichen Farbkomponenten entsprechen,
  - wobei die Anzahl von Abstandshaltern kleiner ist als die Anzahl von Pixeln,
  - jedes Pixel mit maximal einem Abstandshalter versehen ist, und
  - die zweite Alignment-Schicht Reibbehandlung in einer Richtung einer ersten Diagonale jedes Pixels unterzogen worden ist,
  - dadurch gekennzeichnet, dass**
  - in einer Reihe von Pixeln, die in der Richtung der ersten Diagonale entlang einer Richtung der Reibbehandlung angeordnet sind, nicht mehr als ein säulenförmiger Abstandshalter pro Pixel

- vorhanden ist und wenigstens ein säulenförmiger Abstandshalter, jedoch nicht mehr als zwei säulenförmige Abstandshalter pro drei aufeinanderfolgende Pixel vorhanden ist/sind.
2. Flüssigkristall-Anzeigevorrichtung nach Anspruch 1, **dadurch gekennzeichnet, dass** in der Reihe von Pixeln, die in der Richtung der ersten Diagonale angeordnet sind, zwei aufeinanderfolgende Pixel mit Abstandshaltern versehen sind.
  3. Flüssigkristall-Anzeigevorrichtung nach Anspruch 2, **dadurch gekennzeichnet, dass** in der Reihe von Pixeln, die in der Richtung der ersten Diagonale angeordnet sind, zwei aufeinanderfolgende Pixel, die jeweils mit Abstandshaltern versehen sind, und zwei aufeinanderfolgende Pixel, die nicht mit Abstandshaltern versehen sind, abwechselnd angeordnet sind.
  4. Flüssigkristall-Anzeigevorrichtung nach Anspruch 1, **dadurch gekennzeichnet, dass** in einer Reihe von Pixeln, die in der Zeilen-Richtung angeordnet sind, wenigstens ein und maximal zwei von drei aufeinanderfolgenden Pixeln jeweils mit einem Abstandshalter versehen ist/sind.
  5. Flüssigkristall-Anzeigevorrichtung nach Anspruch 4, **dadurch gekennzeichnet, dass** in einer Reihe von Pixeln, die in der Spalten-Richtung angeordnet sind, wenigstens ein und maximal drei von vier aufeinanderfolgenden Pixeln jeweils mit einem Abstandshalter versehen ist/sind.
  6. Flüssigkristall-Anzeigevorrichtung nach einem der Ansprüche 1 bis 5, **dadurch gekennzeichnet, dass** die unterschiedlichen Farbkomponenten in Streifen angeordnet sind.
  7. Flüssigkristall-Anzeigevorrichtung nach einem der Ansprüche 1 bis 6, **dadurch gekennzeichnet, dass** die unterschiedlichen Farbkomponenten Rot-, Grün- und Blau-Farbkomponenten sind und die Abstandshalter in Bereichen ausgebildet sind, die den Grün-Komponenten entsprechen.
  8. Flüssigkristall-Anzeigevorrichtung nach einem der Ansprüche 1 bis 7, **dadurch gekennzeichnet, dass** die Abstandshalter säulenförmige Abstandshalter umfassen.
  9. Flüssigkristall-Anzeigevorrichtung nach einem der Ansprüche 1 bis 8, **dadurch gekennzeichnet, dass** die Anzahl von Abstandshaltern der Hälfte der Anzahl von Pixeln entspricht.
  10. Flüssigkristall-Anzeigevorrichtung nach einem der Ansprüche 1 bis 9, **dadurch gekennzeichnet, dass**

die zweite Alignment-Schicht die Abstandshalter abdeckt.

11. Flüssigkristall-Anzeigevorrichtung nach einem der Ansprüche 1 bis 10, **dadurch gekennzeichnet, dass** die Abstandshalter an den gleichen Positionen wie die jeweils mit den Abstandshaltern versehenen Pixel angeordnet sind.

## Revendications

1. Dispositif d'affichage à cristaux liquides comprenant :

un premier substrat (1) prévu avec un premier film d'alignement (6) sur sa surface ;  
 un seconde substrat (11) agencé pour faire face à la surface du premier substrat sur lequel le premier film d'alignement est prévu, et prévu avec un second film d'alignement (16) sur sa surface qui fait face au premier substrat ;  
 une pluralité d'espaceurs (15) formés sur le second substrat et maintenant une distance entre le premier substrat et le second substrat ; et  
 une pluralité de pixels agencés dans une direction de ligne et une direction de colonne, et ayant respectivement une pluralité d'électrodes de pixel (4R, 4G, 4B) ou une pluralité de filtres de couleur (13R, 13G, 13B) qui correspondent respectivement à différents composants de couleur,  
 le nombre d'espaceurs étant inférieur au nombre de pixels,  
 chaque pixel étant prévu avec un espaceur au maximum, et  
 le second film d'alignement ayant été soumis au traitement par frottement dans une direction d'une première diagonale de chaque pixel,  
**caractérisé en ce que**  
 dans une série de pixels agencés dans la direction de la première diagonale le long d'une direction du traitement par frottement, on ne prévoit pas plus d'un espaceur colonnaire par pixel, et on prévoit au moins un, mais pas plus de deux, espaceurs colonnaires pour trois pixels consécutifs.

2. Dispositif d'affichage à cristaux liquides selon la revendication 1, **caractérisé en ce que**, dans la série de pixels agencés dans la direction de la première diagonale, deux pixels consécutifs sont prévus avec des espaceurs.
3. Dispositif d'affichage à cristaux liquides selon la revendication 2, **caractérisé en ce que**, dans la série de pixels agencés dans la direction de la première diagonale, deux pixels consécutifs respectivement

prévus avec des espaceurs et deux pixels consécutifs non prévus avec des espaceurs sont agencés de manière alternée.

4. Dispositif d'affichage à cristaux liquides selon la revendication 1, **caractérisé en ce que**, dans une série de pixels agencés dans la direction de ligne, au moins un et au maximum deux des trois pixels consécutifs sont chacun prévus avec un espaceur. 5  
10
5. Dispositif d'affichage à cristaux liquides selon la revendication 4, **caractérisé en ce que**, dans une série de pixels agencés dans la direction colonnaire, au moins un et au maximum trois des quatre pixels consécutifs sont chacun prévus avec un espaceur. 15
6. Dispositif d'affichage à cristaux liquides selon l'une quelconque des revendications 1 à 5, **caractérisé en ce que** les différents composants de couleur sont agencés en bandes. 20
7. Dispositif d'affichage à cristaux liquides selon l'une quelconque des revendications 1 à 6, **caractérisé en ce que** les différents composants de couleur sont des composants de couleur rouge, verte et bleue ; et les espaceurs sont formés dans les régions correspondant aux composants verts. 25
8. Dispositif d'affichage à cristaux liquides selon l'une quelconque des revendications 1 à 7, **caractérisé en ce que** les espaceurs comprennent des espaceurs colonnaires. 30
9. Dispositif d'affichage à cristaux liquides selon l'une quelconque des revendications 1 à 8, **caractérisé en ce que** le nombre d'espaceurs représente la moitié du nombre de pixels. 35
10. Dispositif d'affichage à cristaux liquides selon l'une quelconque des revendications 1 à 9, **caractérisé en ce que** le second film d'alignement couvre les espaceurs. 40
11. Dispositif d'affichage à cristaux liquides selon l'une quelconque des revendications 1 à 10, **caractérisé en ce que** les espaceurs sont agencés dans les mêmes positions des pixels respectifs prévus avec les espaceurs. 45

50

55

FIG.1

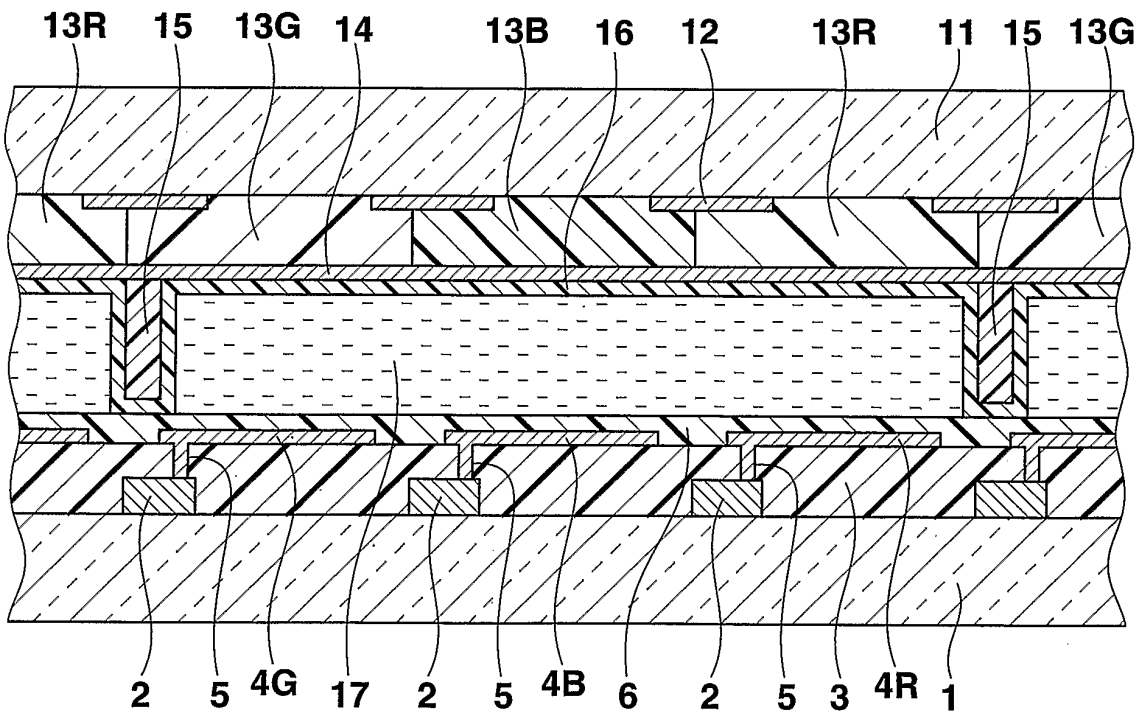
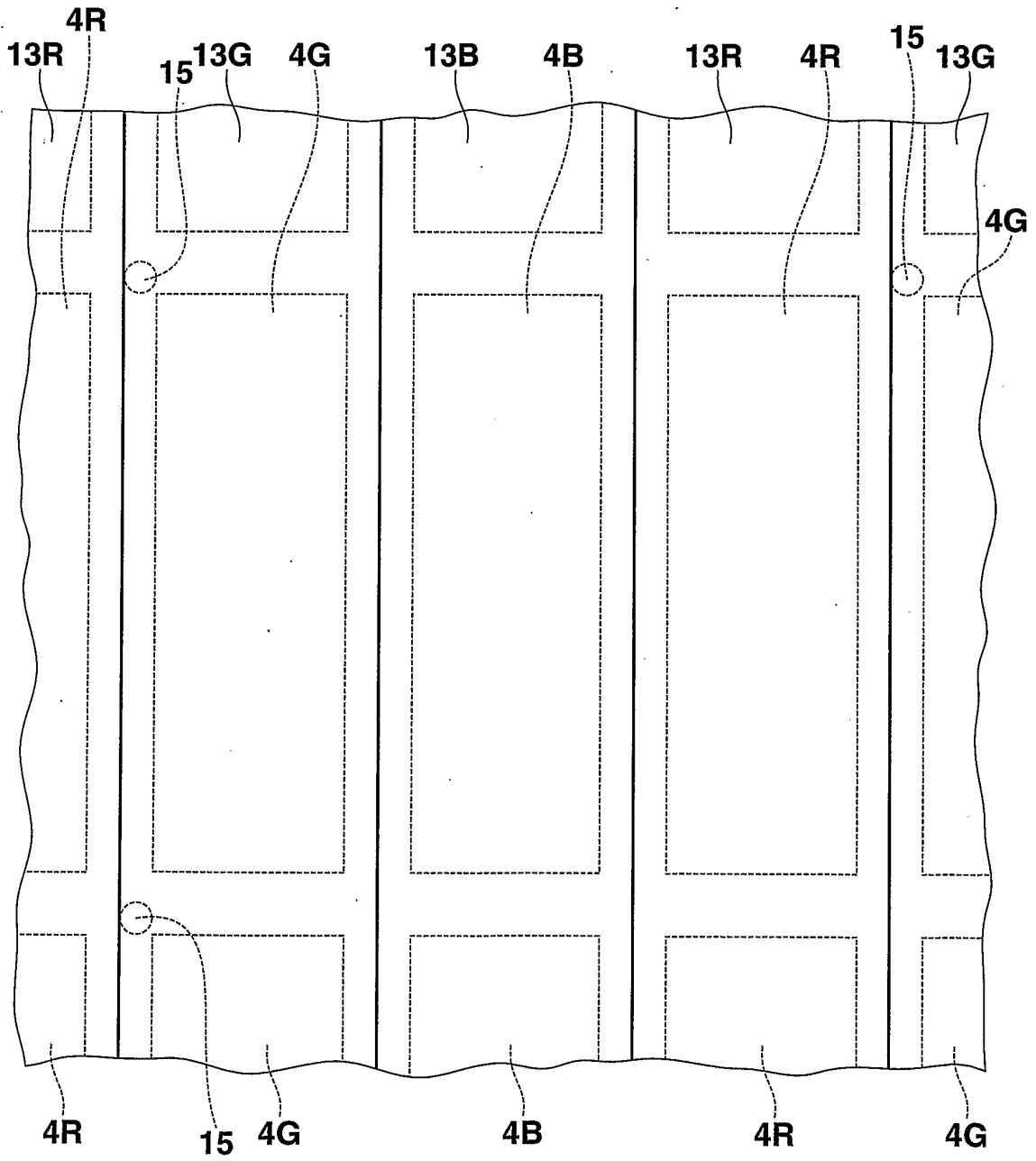
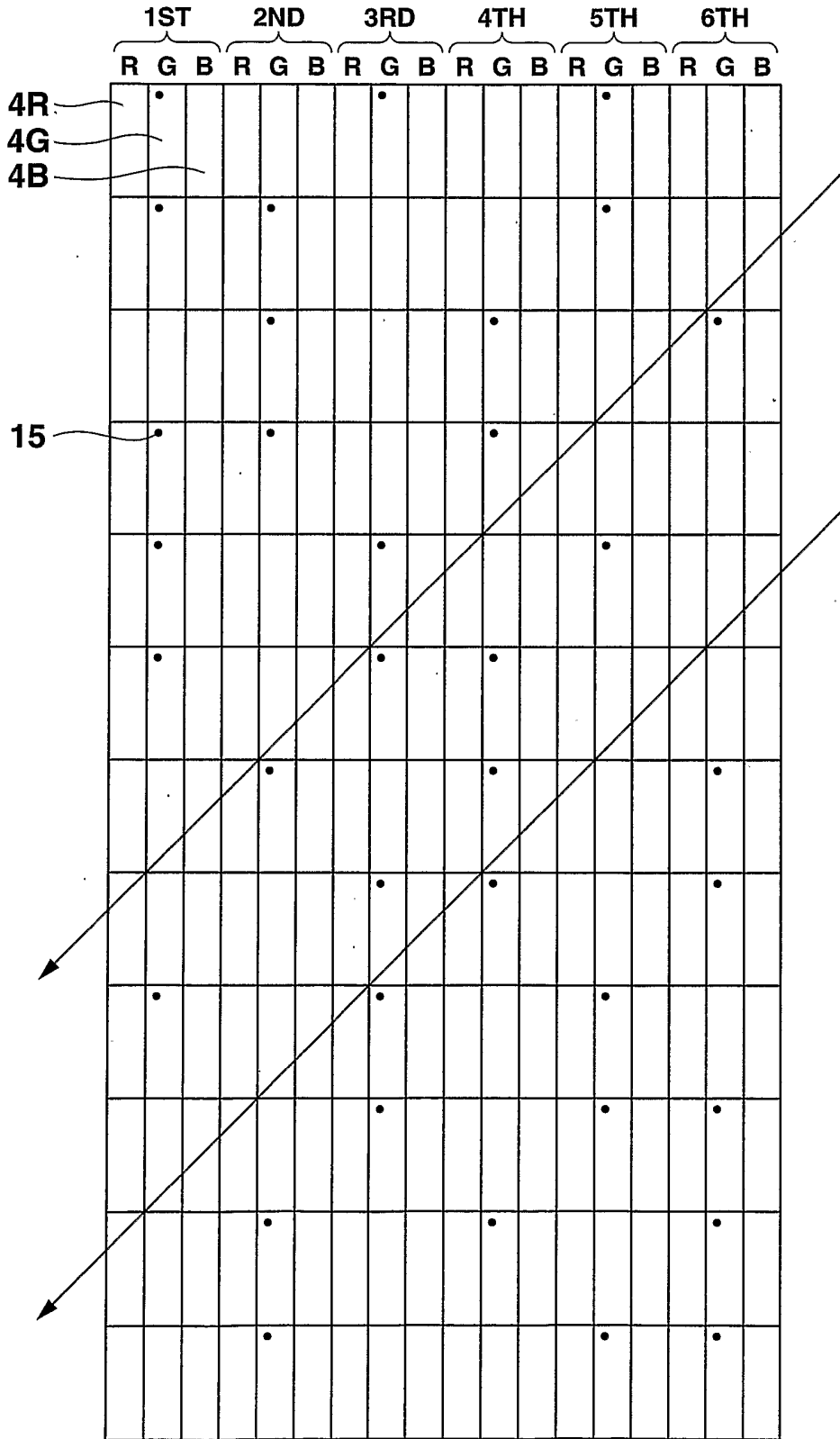

FIG.2



**FIG.3**



**REFERENCES CITED IN THE DESCRIPTION**

*This list of references cited by the applicant is for the reader's convenience only. It does not form part of the European patent document. Even though great care has been taken in compiling the references, errors or omissions cannot be excluded and the EPO disclaims all liability in this regard.*

**Patent documents cited in the description**

- JP 2005017494 B [0001]
- JP 2002214621 A [0002]

专利名称(译)	液晶显示装置包括隔离物		
公开(公告)号	<a href="#">EP1994442B1</a>	公开(公告)日	2015-12-30
申请号	EP2007737741	申请日	2007-02-27
[标]申请(专利权)人(译)	卡西欧计算机株式会社		
申请(专利权)人(译)	CASIO COMPUTER CO., LTD.		
当前申请(专利权)人(译)	CASIO COMPUTER CO., LTD.		
[标]发明人	YANAGISAWA MASAKI		
发明人	YANAGISAWA, MASAKI		
IPC分类号	G02F1/1339		
CPC分类号	G02F1/13394 G02F1/133784		
优先权	2006051633 2006-02-28 JP		
其他公开文献	EP1994442A1		
外部链接	<a href="#">Espacenet</a>		

摘要(译)

一种液晶显示装置，包括：第一基板，在其一个表面上设置有取向膜；以及第二基板，在其一个表面上设置有取向膜。第一基板和第二基板布置成彼此相对，其中对准膜位于相对的第一和第二基板内。间隔物（15）插入在第一和第二基板之间，并且像素以矩阵形式排列在显示装置中。间隔物（15）布置成使得沿着第二基板的取向膜的摩擦处理方向，每个像素设置不多于一个间隔物（15），每三个连续存在至少一个间隔物（15）像素，并且没有三个连续像素都具有与其对应的相应间隔物（15）。

