



(12) **EUROPEAN PATENT APPLICATION**

(43) Date of publication:
13.09.2000 Bulletin 2000/37

(51) Int. Cl.⁷: **G09G 3/36**

(21) Application number: **00104521.0**

(22) Date of filing: **10.03.2000**

(84) Designated Contracting States:
**AT BE CH CY DE DK ES FI FR GB GR IE IT LI LU
MC NL PT SE**
Designated Extension States:
AL LT LV MK RO SI

(72) Inventor: **Sakumoto, Aiichiro**
Chigasaki-shi, Kanagawa-ken (JP)

(74) Representative: **HOFFMANN - EITLÉ**
Patent- und Rechtsanwälte
Arabellastrasse 4
81925 München (DE)

(30) Priority: **11.03.1999 JP 6547299**

(71) Applicant:
KABUSHIKI KAISHA TOSHIBA
Kanagawa-ken 210 (JP)

(54) **Liquid crystal display apparatus and method for driving the same**

(57) The present invention provides a liquid crystal display apparatus capable of reducing waving and shadowing. The driving circuit portion in the liquid crystal display apparatus according to the present invention has a random number generating circuit 2, a display data RAM 3, a display data RAM address decoder 7, and a row driver 8. The random number generating circuit 2 generates random numbers for setting the scanning order of the row electrodes. The row address decoder 7 sets the scanning order on the row elec-

trodes. The column driver 6 supplies the video data of all the column electrodes corresponding to the scanning row electrode. The scanning order of the scanning lines is set by the random numbers generated by the random number generating circuit 2. Because of this, the scanning order becomes random at each frame, and the shadowing depending to the video data is reduced. Furthermore, because the adjacent scanning lines are not continuously scanned, the waving does not arise.

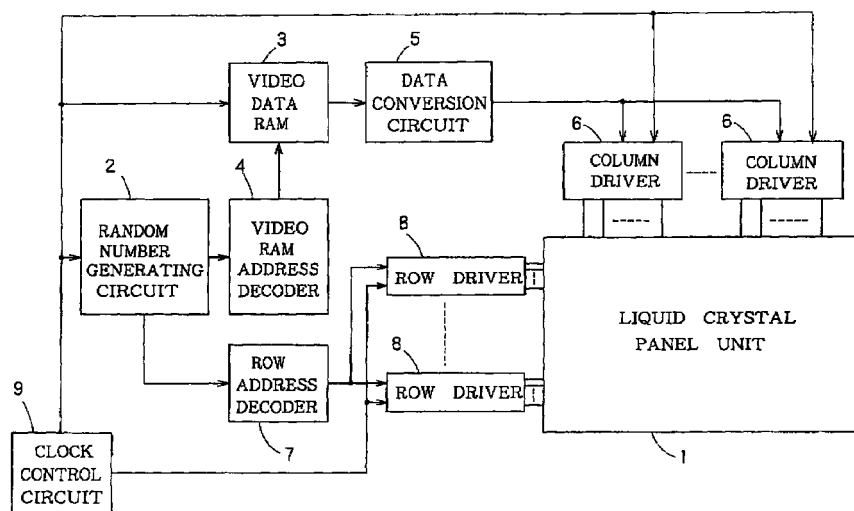

FIG. 2

DescriptionBACKGROUND OF THE INVENTIONField of the Invention

[0001] The present invention relates to a liquid crystal display apparatus of a simple matrix driving type, which has a plurality of row electrodes (scanning lines) and column electrodes (signal lines) arranged in matrix form, and drives all of column electrodes during driving one row electrode.

Related Background Art

[0002] In the liquid crystal display (LCD) apparatus of the simple matrix driving type, there is a system scanning the row electrodes arranged to a horizontal direction of a display screen line by line. On the LCD screen, only one line is lightened in a moment. However, because lightening is repeatedly carried out, an eye of human is perceived so that all the screen is lightening.

[0003] On the other hand, when the LCD screen becomes large and the number of the scanning lines increases, if each row electrode is not scanned at high speed, a flicker is likely visible. In order to reduce the flicker, it is necessary to set the number of scanning frame to more than 25 times per one minute. One frame time, that is, a lightening time for one line is set by the number of scanning frames per one minute. The more the number of the scanning lines is, the shorter the lightening time is. The shorter the lightening time for one line is, the lower the ratio of ON/OFF of the liquid crystal, that is, a contrast ratio becomes; as a result, the more the screen image is blurred.

[0004] By improvement of the liquid crystal material, it is possible to compensate deterioration of the contrast. However, undesirable problems such as shadowing and waving occurs, thereby deteriorating display quality. The shadowing designates a phenomenon that shadow emerges at non-lightening points, as shown in Fig. 1. In order to reduce the shadowing, it is general to detect turning point of the ON/OFF of the liquid crystal and to apply a supplement voltage at the points. However, because a circuit for detecting the turning points of the ON/OFF and a circuit for applying the supplement voltage has to be added, the cost is up and mounting area becomes necessary too much.

[0005] Next, the waving will be explained. The liquid crystal has a characteristic that its properties deteriorate when the voltage is applied only to one direction. Therefore, ordinarily, the polarity of the voltage applied to the liquid crystal is periodically switched, and the voltage applied to the liquid crystal is controlled so as to become plus minus zero. As a specific method of the polarity inversion, there are a frame inversion that the polarity inverts at each frame (each screen), and a dot inversion that the polarity inverts at each dot.

[0006] For example, in the case of the line inversion, if the polarity inversion is carried out at every sub-multiple pieces of all the horizontal lines, the polarity is inverted by the same line at each frame. As a result, the line showing change-over of the polarity is perceived.

[0007] On the other hand, in the case of the frame inversion, as a property of CMOS transistor constituting the driving circuit, penetrating current flows. Therefore, the driving voltage goes down and the contrast changes undesirably.

[0008] Because of this, in the liquid crystal display apparatus of simple matrix driving type, the polarity is switched at every prime factor pieces of lines, for example, 13 or 17 pieces. When the polarity is switched at every the prime factor pieces of lines, a least common for the number of all lines becomes large, and the location that the polarity of the driving voltage switches changes at each frame. As a result, the line showing change-over of the polarity is not perceived.

[0009] However, even if inverting the polarity at every prime factor pieces of lines, there is a case that the line to switch the polarity inversion is perceived so that the wave flows. In order to reduce such a waving, it is necessary to provide the horizontal lines more than the number of the horizontal lines in the display area and to prevent the occurrence of the wave by controlling a surplus divided by a prime factor. Because of this, the scanning control is complicated and a new circuit becomes necessary.

SUMMARY OF THE INVENTION

[0010] The present invention has been developed in consideration of the above-described respects, and a object of the present invention is to provide a liquid crystal display apparatus capable of reducing the shadowing and the waving.

[0011] To attain the above-described object, according to the present invention, there is provided a liquid crystal display apparatus comprising:

- a plurality of row electrodes and column electrodes arranged in matrix form;
- a row electrode driving circuit for driving each of said row electrodes in random order; and
- a column electrode driving circuit for driving each of said column electrodes.

[0012] According to the present invention, because each of the row electrodes is driven in random, it is possible to reduce the shadowing depending to the video data. Furthermore, because the adjacent row electrodes are not continuously scanned, the waving does not occur and the display quality is improved.

[0013] In the present invention, if pattern strings showing the scanning order of the row electrodes is stored in the storing apparatus in advance, it is possible to quickly decide the scanning order of the row elec-

trodes and to surely drive each of the row electrodes within a prescribed time, even if there are a lot of the row electrodes.

BRIEF DESCRIPTION OF THE DRAWINGS

[0014]

Fig. 1 is a diagram explaining the shadowing.

Fig. 2 is a block diagram showing a first embodiment of a liquid crystal display apparatus.

Fig. 3 is scanning order patterns stored in the non-volatile memory.

Fig. 4A-4B is a diagram showing scanning order.

Fig. 5 is a block diagram showing the second embodiment of a liquid crystal display apparatus.

Fig. 6 is a diagram showing a relationship between the output of the address counter and the corresponding data read out from the row electrodes.

DESCRIPTION OF THE PREFERRED EMBODIMENTS

[0015] Preferred embodiments of the present invention will be described below with reference to the drawings.

(First Embodiment)

[0016] Fig. 2 is a block diagram showing a first embodiment of a liquid crystal display apparatus according to the present invention. The liquid crystal display apparatus of Fig. 2 has a module on which a liquid crystal panel unit 1 and a portion of a driving circuit are formed.

[0017] The driving circuit of the liquid crystal display apparatus according to the present invention, as shown in Fig. 2, has a random number generating circuit 2, a video data RAM 3, a video RAM address decoder 4, a data conversion circuit 5, a column driver 6, a row address decoder 7, and a row driver 8.

[0018] The random number generating circuit 2 generates random numbers which is used to set scanning order of the row electrodes L1-Ln. The random number generated by the random number generating circuit 2 does not need to be a complete random number. the random number may be pseudo random numbers constituted of pattern string with long period. For example, the random number generating circuit 2 may be provided with a ROM for storing a plurality of patterns showing the scanning order of the row electrodes L1-Ln, and the scanning order may be set by reading out the patterns showing the scanning order in the ROM.

[0019] The video data RAM 3 is a RAM for storing the video data. Because the scanning order changes randomly, a frame buffer capable of storing the video data for one screen is used.

[0020] The video RAM address decoder 4 is a decoder for selecting data stored in the video data RAM 3, and decodes addresses of the video data RAM 3 corresponding to the random number outputted from the random number generating circuit 2.

[0021] The data conversion circuit 5 is constituted in the same way as the conventional circuit, and carries out a parallel/serial conversion of the video data in accordance with the number of the input data bits of the column driver 6.

[0022] The column driver 6 is constituted in the same way as the conventional one, and supplies the video data supplied from the data conversion circuit 5 to each column line at a time.

[0023] The row address decoder 7 sets the scanning order based on the random number outputted from the random number generating circuit 2. Specifically, the row address decoder 7 supplies to the row driver 8 a chip select signal of the row driver 8 constituted of a plurality of chips and a signal showing the display output order.

[0024] The row address decoder 8 becomes an enable status by the chip select signal from the row address decoder 7. The row driver 8 selects its output terminal by a decoder in the row driver 8, based on a signal showing the display output order from the row address decoder 7, and then scans each of the row lines L1-Ln based on the selected result.

[0025] Next, the operation of the liquid crystal display apparatus showing in Fig. 2 will be explained. The following is an example of having a nonvolatile memory such as ROM or RAM for storing a plurality of types of the scanning order patterns. The scanning order patterns stored in the nonvolatile memory, for example, as shown in Fig. 3, are constituted of pattern strings with the same number as that of the row electrodes L1-Ln. The numeral of Fig. 3 shows the numeral of the row electrodes. In the nonvolatile memory, a lot of patterns as shown in Fig. 3 is stored. These patterns are constituted of numeral strings close to the random number so that the scanning order of the row electrodes L1-Ln does not coincide at each frame.

[0026] The random number generating circuit 2 repeatedly reads out the patterns showing the scanning order stored in the nonvolatile memory. When the patterns are repeatedly read out, the random number generating circuit 2 outputs the same pattern at every prescribed period. When many patterns are stored in the nonvolatile memory, there is few frequency to read out the same pattern. As a result, the same advantageous effect as that by outputting the random number is obtained.

[0027] The patterns showing the scanning order outputted from the random number generating circuit 2 is inputted to the video data RAM address decoder 4 and the row address decoder 7. The video data RAM address decoder 4 selects addresses of the video data corresponding to the scanning row electrodes based on

the pattern showing the scanning order, and supplies the selected address to the video data RAM 3. The video data RAM 3 outputs the video data in accordance with the scanning row electrodes. The video data read out from the video data RAM 3 is converted from parallel data to serial data, and then supplied to the column driver 6. The column driver 6 supplies these video data to each of the column electrodes C1-Cm at the same timing.

[0028] On the other hand, the row address decoder 7 sets the scanning order of the row electrodes L1-Ln, based on the patterns showing the scanning order outputted from the random number generating circuit 2. The row driver 8 drives each of the row electrodes L1-Ln in accordance with the order the row address decoder 7 sets.

[0029] Accordingly, in a certain frame, for example, the scan is carried out in an order showing in Fig. 4A, and in the next frame, so that the scanning order is different from the previous frame, the scan is carried out in an order showing in Fig. 4B. The numerals of Fig. 4A and 4B express the scanning order.

[0030] Thus, the first embodiment sets the scanning order of the scanning lines in accordance with the random numbers generated by the random number generating circuit 2. Because of this, the scanning order becomes random at every frame, and the shadowing depending on the video data is reduced. That is, even when displaying the image that the shadowing is subject to happen, the occurrence of the shadowing is prevented.

[0031] Furthermore, because the adjacent scanning lines are scanned continuously, the waving does not happen and the display quality is improved.

[0032] Because the patterns showing the scanning order are stored in advance in the random number generating circuit 2, it is possible to quickly decide the scanning order. Accordingly, even when there are many row electrodes, it is possible to drive all the row electrodes within a prescribed time. Furthermore, it is possible to use the conventional data conversion circuit 5 and column driver 6 as it is, thereby cutting cost for design change.

(Second Embodiment)

[0033] A second embodiment has a feature that a ROM is used as the random number generating circuit.

[0034] Fig. 5 is a block diagram showing the second embodiment of a liquid crystal display apparatus according to the present invention. In Fig. 5, the constituents common to those of Fig. 1 are denoted with the same reference numerals, and mainly the different respects will be described hereinafter.

[0035] The liquid crystal display apparatus of Fig. 5 has an address counter 11 and the random data ROM 12, instead of the display data RAM address decoder.

[0036] The address counter 11 outputs read-out

addresses of the random data ROM 12. Specifically, the address incremented one by one is outputted.

[0037] In the inside of the random data ROM 12, the random data showing the order scanning the row electrodes is stored. Fig. 6 is a diagram showing a relationship between the output of the address counter 11 and the corresponding data read out from the row electrodes, and shows an example having 240 pieces of the row electrodes. As shown in Fig. 6, when the address increments one by one, the random data is outputted from the random data ROM 12.

[0038] Data read out from the random data ROM 12 is transferred to the row address decoder 7 and the video data RAM 3. The row address decoder 7 decides the scanning order of the row electrodes based on data read out from the random data ROM 12. The video data RAM 3 decides the order to read out the video data.

[0039] The column driver 6 drives all the column electrodes at the same timing, based on the video data read out from the video data RAM 3.

[0040] Furthermore, the random data ROM 12 of Fig. 5 is applicable to any nonvolatile memory such as mask ROM, EPROM, EEPROM, and FRAM.

[0041] In the above-mentioned second embodiment, examples providing the ROM for storing the patterns showing the scanning order in the random number generating circuit 2 have been explained. The patterns showing the scanning order may be stored in the RAM, and the patterns showing the scanning order may be programmably changed.

[0042] Otherwise, instead of storing the patterns showing the scanning order in advance, the random numbers may be calculated and the scanning order may be set at each scanning of the scanning lines.

Claims

1. A liquid crystal display apparatus comprising:
 - a plurality of row electrodes and column electrodes arranged in matrix form;
 - a row electrode driving circuit for driving each of said row electrodes in random order; and
 - a column electrode driving circuit for driving each of said column electrodes.
2. A liquid crystal display apparatus according to claim 1,
 - said column electrode driving circuit drives all of the column electrodes while said row electrode driving circuit drives one row electrode.
3. A liquid crystal display apparatus according to claim 1, further comprising a random data output circuit for outputting random data,
 - wherein said row electrode driving circuit decides driving order of said row electrodes based

- on said random data.
4. A liquid crystal display apparatus according to claim 3,
 wherein said random data is any among random numbers, pseudo random numbers, and data with a long period.
5. A liquid crystal display apparatus according to claim 3, further comprising:
 a video memory for storing video data; and
 a video address decoder for deciding order to read out said video memory,
 wherein said column electrode driving circuit drives all of said column electrodes at the same timing, based on the video data read out from said video memory in accordance with the decided read-out order.
6. A liquid crystal display apparatus according to claim 3,
 wherein said random data output circuit has a storing apparatus for storing a plurality of pattern strings showing the order for driving said row electrodes, and an address generating apparatus for outputting addresses to read out the pattern strings stored in said storing apparatus.
7. A liquid crystal display apparatus according to claim 6,
 wherein said row electrode driving circuit reads out the pattern strings stored in said storing apparatus, and decides the order for driving said row electrodes, based on each of the read-out pattern strings.
8. A liquid crystal display apparatus according to claim 7,
 wherein said row electrode driving circuit and said column electrode driving circuit allow the polarity of voltage applied to both of said row electrodes and said column electrodes at every multiple row electrodes to invert, and said random data output circuit sets a type of said pattern strings for storing in said storing apparatus.
9. A liquid crystal display apparatus according to claim 6,
 wherein said storing apparatus is a read-only memory.
10. A liquid crystal display apparatus according to claim 9,
 wherein said storing apparatus is any among mask ROM, EPROM, EEPROM and FRAM.
11. A liquid crystal display apparatus according to claim 6,
 wherein said storing apparatus is a readable and writable memory.
12. A method for driving a liquid crystal display apparatus comprising a plurality of row electrodes and column electrodes arranged in matrix form, a row electrode driving circuit for driving each of said row electrodes, and a column electrodes for driving each of said column electrodes,
 wherein said row electrodes are driven in random order, respectively.
13. A method for driving a liquid crystal display apparatus according to claim 12,
 wherein said column electrode driving circuit drives all the column electrodes while said row electrode driving circuit drives one row electrode.
14. A method for driving a liquid crystal display apparatus according to claim 12,
 wherein said row electrode driving circuit decides the order for driving said row electrodes, based on random data outputted from a random data output circuit.
15. A method for driving a liquid crystal display apparatus according to claim 14,
 wherein said random data is any among random numbers, pseudo random numbers, and data for long period.
16. A method for driving a liquid crystal display apparatus according to claim 12, comprising step of deciding read-out order of the video memory for storing video data,
 wherein said column electrode driving circuit drives all of said column electrodes at the same timing, based on the video data read out from said video memory in accordance with the decided read-out order.
17. A method for driving a liquid crystal display apparatus according to claim 16,
 said step of deciding read-out order of the video memory has further the steps of:
 storing a plurality of pattern strings showing the order for driving said row electrodes; and
 outputting addresses for reading out the pattern strings stored in said storing apparatus.
18. A method for driving a liquid crystal display apparatus according to claim 17,
 said row electrode driving circuit repeatedly reads out the pattern strings stored in said storing apparatus in order, and decides the order

for driving said row electrodes based on each of the read-out pattern strings.

- 19.** A method for driving a liquid crystal display apparatus according to claim 12, 5
wherein said row electrode driving circuit and said column electrode driving circuit allow polarity of voltage applying to said row electrodes and said column electrodes to invert at every multiple row electrodes, and said random data output 10
circuit sets a type of said pattern strings for storing in said storing apparatus, so that line showing polarity inversion is not perceived.

15

20

25

30

35

40

45

50

55

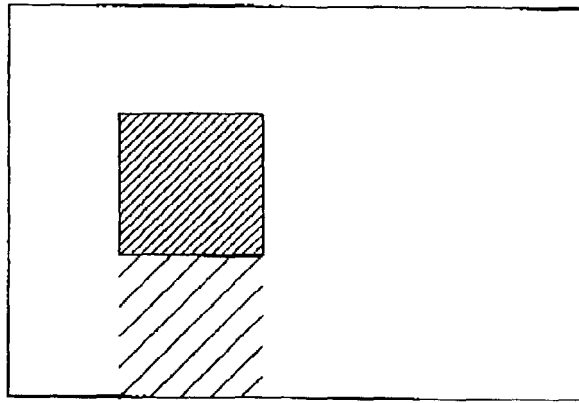

FIG. 1

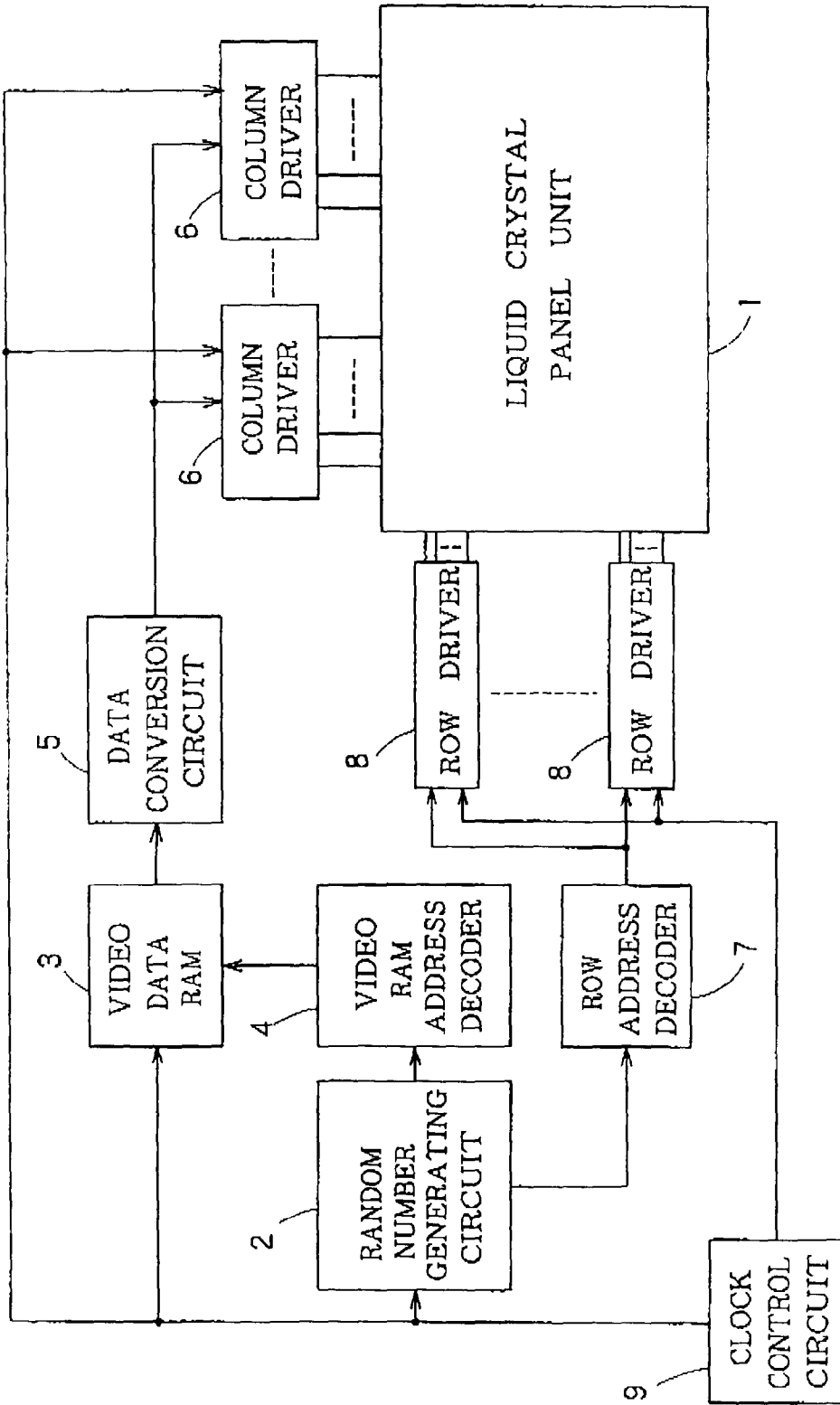

FIG. 2

25, 192, 64, 121, 3, 54, 68, 19, ...
181, 63, 72, 38, 145, 139, 6, 95, ...
89, 17, 48, 27, 156, 174, 24, 112, ...
⋮

FIG. 3

94	
173	
6	
25	
132	
68	
	⋮

FIG. 4A

21	
3	
127	
185	
16	
54	
	⋮

FIG. 4B

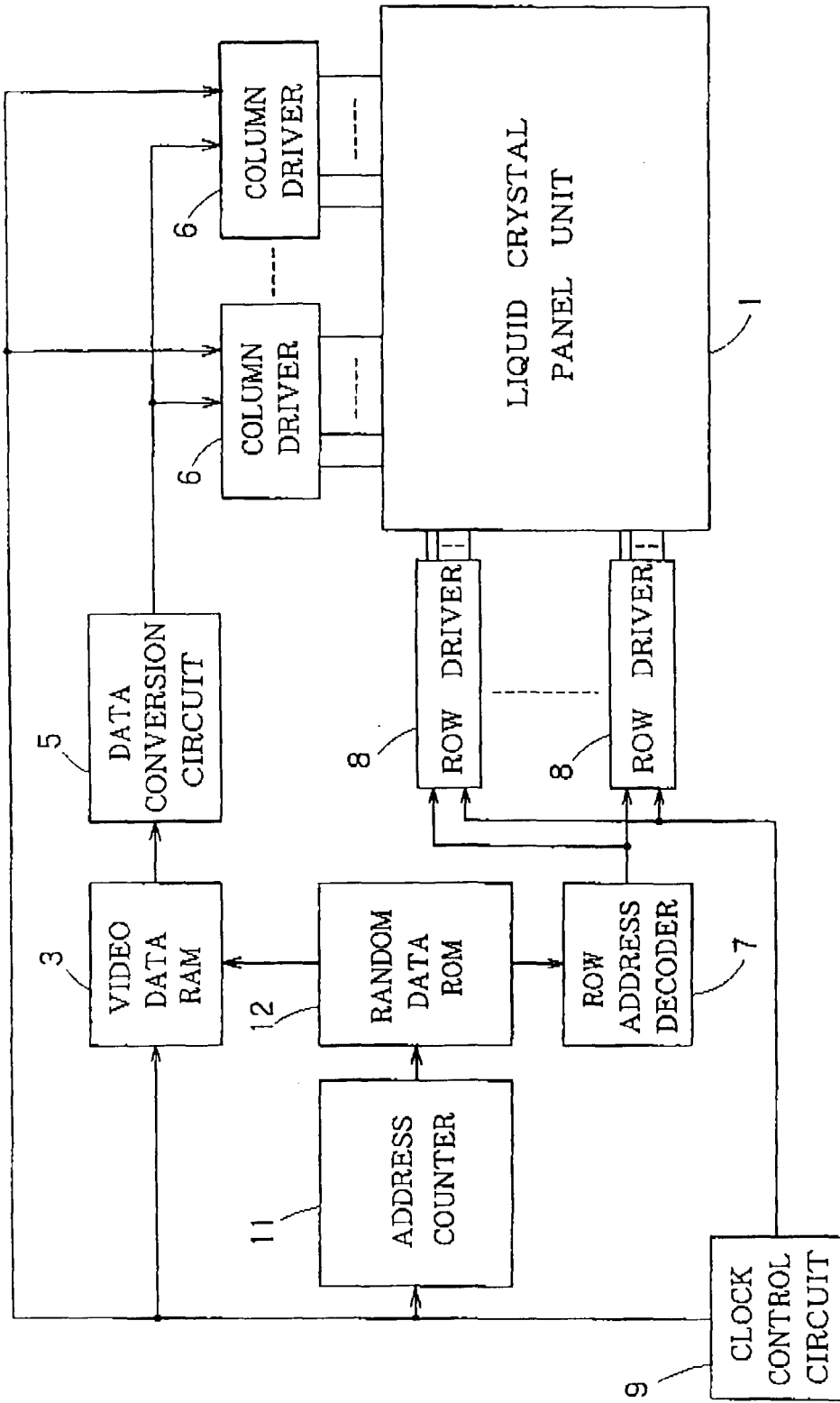

FIG. 5

ADDRESS DATA FROM ADDRESS COUNTER	DATA STORED IN ROM
00h	E7h
01h	60h
03h	A3h
04h	54h
05h	9Fh
06h	55h
07h	CEh
.	.
.	.
.	.
.	.
.	.
EDh	96h
EEh	1Dh
EFh	03h
F0h	5Ah

FIG. 6



European Patent Office

EUROPEAN SEARCH REPORT

Application Number
EP 00104521.0

DOCUMENTS CONSIDERED TO BE RELEVANT			
Category	Citation of document with indication, where appropriate, of relevant passages	Relevant to claim	CLASSIFICATION OF THE APPLICATION (Int. Cl. 7)
X	EP 0837445 A (CANON KABUSHIKI KAISHA) 22 April 1998, claims 1,2,12,13, fig. 1,2-2H.	1,2,	G09G3/36
A	--	3,5, 10,12, 13,16, 17	
A	WO 95/20210 A (ARITHMOS INC.) 27 July 1995, abstract, claims 10-20, fig. 1,2.	1,2,3, 5,10, 12,13, 16,19	
A	US 5751261 A (ZAVRACKY et al.) 12 May 1998, abstract, fig.1.	1,2,3, 5,10, 12,16, 17	
A	WO 96/16393 A (PHILIPS ELECTRONICS E.V.) 30 June 1996, claim 1, fig.1. ----	1,2	
			TECHNICAL FIELDS SEARCHED (Int. Cl. 7)
			G09G G02F
The present search report has been drawn up for all claims			
Place of search VIENNA		Date of completion of the search 12-05-2000	Examiner MIHATSEK
<p>CATEGORY OF CITED DOCUMENTS</p> <p>X: particularly relevant if taken alone Y: particularly relevant if combined with another document of the same category A: technological background O: non-written disclosure P: intermediate document T: theory or principle underlying the invention</p> <p>E: earlier patent document, but published on, or after the filing date D: document cited in the application L: document cited for other reasons</p> <p>&: member of the same patent family, corresponding document</p>			

EPA Form 1503 03 82

ANNEX TO THE EUROPEAN SEARCH REPORT
ON EUROPEAN PATENT APPLICATION NO. EP 00104521.0

This annex lists the patent family members relating to the patent documents cited in the above-mentioned search report. The members are as contained in the EPIDOS (INPADOC) file on 15. 6.1970. The European Patent Office is in no way liable for these particulars which are merely given for the purpose of information.

Patent document cited in search report	Publication date	Patent family member(s)	Publication date
EP A1 837445	22-04-1998	JP A2 10177162	30-06-1998
WO A2 9520210	27-07-1995	AU A1 16890/95	08-08-1995
		EP A1 722602	24-07-1996
		JP T2 9508219	19-08-1997
		US A 5739803	14-04-1998
		WO A3 9520210	23-11-1995
US A 5751261	12-05-1998	EP A1 565588	20-10-1993
		JP T2 6504139	12-05-1994
		US A 5206749	27-04-1993
		US A 5444557	22-08-1995
		WO A1 9212453	23-07-1992
		US A 5256562	26-10-1993
		US A 5258325	02-11-1993
		US A 5317236	31-05-1994
		US A 5317436	31-05-1994
		US A 5331149	19-07-1994
		US A 5376561	27-12-1994
		US A 5376979	27-12-1994
		US A 5377031	27-12-1994
		US A 5394304	07-03-1995
		US A 5438241	01-08-1995
		US A 5475514	12-12-1995
		US A 5499124	12-03-1996
		US A 5539550	23-07-1996
		US A 5581385	03-12-1996
		US A 5583335	10-13-1996
		US A 5661371	26-08-1997
		US A 5666175	09-09-1997
		US A 5702963	30-12-1997
		US A 5713652	03-02-1998
		US A 5743614	28-04-1998
		US A 5757445	26-05-1998
		US A 5861929	19-01-1999
		US A 6043800	28-03-2000
		US A 5258320	02-11-1993
		US A 5362671	08-11-1994
		US A 5736768	07-04-1998
		EP A1 647383	12-04-1995
		EP A1 935389	11-08-1999
		JP T2 7503557	13-04-1995
		WO A1 9315589	05-08-1993
		US A 5467154	14-11-1995
		US A 5692820	02-12-1997
		US A 5420055	30-05-1995
		US A 5578865	26-11-1996
		AT E 173839	15-12-1998
		DE CO 69322279	07-01-1999
		DE T2 69322279	24-06-1999
		EP A1 659282	28-06-1995
		EP A2 853254	15-07-1998
		EP A3 853254	14-10-1998
		EP B1 659282	25-11-1998
		JP T2 8501887	27-02-1996
		WO A1 9407177	21-04-1994
		US A 5654811	05-08-1997
		US A 5708424	06-01-1998
		WO A1 9525983	28-09-1995
		WO A1 9410794	11-05-1994
		US A 5300788	05-04-1994
		WO A2 9213363	06-08-1992
		US A 5453405	26-09-1995
		EP A1 624099	30-11-1994
		JP T2 7504782	25-05-1995
		WO A1 9316491	19-08-1993
		AT E 180578	15-06-1999
		DE CO 693225110	01-07-1999
		DE T2 693225110	09-12-1999
		EP A1 725939	14-08-1996
		EP A2 909972	21-04-1999
		EP B1 725939	26-05-1999
		EP A3 909972	09-06-1999
		JP T2 7504764	25-05-1995
		WO A2 9318428	16-09-1993
		WO A3 9318428	17-02-1994
		WO A1 9410660	11-05-1994
		US A 5528397	18-06-1996
		WO A1 9418791	18-08-1994
		CA AA 2186160	28-09-1995
		EP A1 752121	08-01-1997
		JP T2 9510797	28-10-1997
WO A1 9616393	30-05-1996	GB A0 9507414	31-05-1995
		EP A1 741898	13-11-1996
		JP T2 9508222	19-08-1997
		US A 5798740	25-08-1998
		GB A0 9423705	11-01-1995

专利名称(译)	液晶显示装置及其驱动方法		
公开(公告)号	EP1035535A1	公开(公告)日	2000-09-13
申请号	EP2000104521	申请日	2000-03-10
[标]申请(专利权)人(译)	株式会社东芝		
申请(专利权)人(译)	株式会社东芝		
当前申请(专利权)人(译)	株式会社东芝		
[标]发明人	SAKUMOTO AIICHIRO		
发明人	SAKUMOTO, AIICHIRO		
IPC分类号	G02F1/133 G09G3/20 G09G3/36 H04N5/66		
CPC分类号	G09G3/3611 G09G3/3622 G09G3/3674 G09G3/3685 G09G2310/02 G09G2320/0209		
优先权	1999065472 1999-03-11 JP		
外部链接	Espacenet		

摘要(译)

本发明提供一种能够减少波浪和阴影的液晶显示装置。根据本发明的液晶显示装置中的驱动电路部分具有随机数产生电路2，显示数据RAM 3，显示数据RAM地址译码器7和行驱动器8。随机数产生电路2产生用于设置行电极扫描顺序的随机数。行地址译码器7在行电极上设置扫描顺序。列驱动器6提供与扫描行电极对应的所有列电极的视频数据。扫描线的扫描顺序由随机数产生电路2产生的随机数设定。因此，扫描顺序在每帧变为随机的，并且减少了依赖于视频数据的阴影。此外，由于不连续扫描相邻的扫描线，因此不会产生波动。

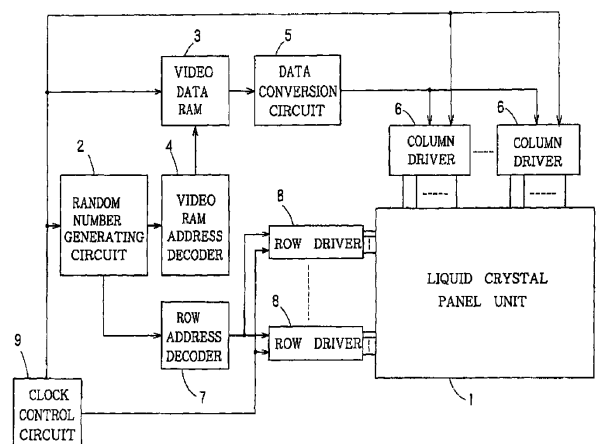

FIG. 2