



(12) **EUROPEAN PATENT APPLICATION**

(43) Date of publication:
27.11.2013 Bulletin 2013/48

(51) Int Cl.:
G02F 1/1333^(2006.01) F21V 8/00^(2006.01)

(21) Application number: **13168931.7**

(22) Date of filing: **23.05.2013**

(84) Designated Contracting States:
AL AT BE BG CH CY CZ DE DK EE ES FI FR GB GR HR HU IE IS IT LI LT LU LV MC MK MT NL NO PL PT RO RS SE SI SK SM TR
 Designated Extension States:
BA ME

(72) Inventors:
 • **Ahn, Joon-seok Gyeonggi-do (KR)**
 • **Park, Jae-hyun Seoul (KR)**

(30) Priority: **25.05.2012 KR 20120056184**
12.11.2012 KR 20120127641

(74) Representative: **Hewett, Jonathan Michael Richard Venner Shipley LLP 200 Aldersgate London EC1A 4HD (GB)**

(71) Applicant: **Samsung Electronics Co., Ltd Gyeonggi-do 443-742 (KR)**

(54) **Liquid crystal display apparatus**

(57) A liquid crystal display (100) is provided. The liquid crystal display (100) includes a liquid crystal panel (110) which is configured to display an image; a backlight (120) which is configured to supply light for displaying the image on the liquid crystal panel (110); a top chassis (130) and bottom chassis (140) which package the liquid crystal panel (110) and backlight unit (120) in one module; and a strength reinforcing member (160) which is mounted to an internal surface (141) of the bottom chassis (140) to reinforce a strength of the bottom chassis (140).

(130) and bottom chassis (140) which package the liquid crystal panel (110) and backlight unit (120) in one module; and a strength reinforcing member (160) which is mounted to an internal surface (141) of the bottom chassis (140) to reinforce a strength of the bottom chassis (140).

FIG. 2

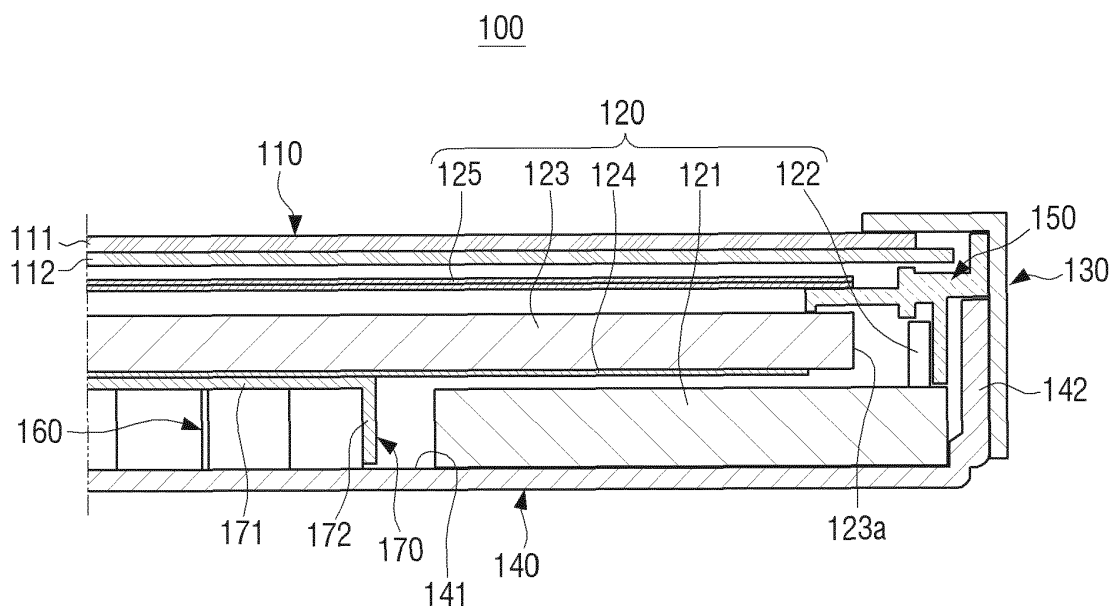

Description

[0001] The present invention relates to a liquid crystal display module, and more particularly, to a liquid crystal display module having improved resistance to deformation.

[0002] A liquid crystal display may be provided in a flat panel or a curved panel display configuration. In either case, where the flat panel or curved panel display becomes deformed by weight, an external force, or heat etc. from a manufactured flatness or curvature, there is a disadvantage in that deterioration of the image quality of the display increases.

[0003] It has been proposed to form a beading structure on a surface of a chassis of the display to attempt to reinforce the strength of the display. However, there is a disadvantage in that such beading increases the size and weight of the display as the display becomes larger in size. Thus, as the display becomes larger in size, a beading structure becomes less and less effective in preventing deformation.

[0004] Alternatively, it has been proposed to increase a thickness of the chassis in order to prevent deformation. However, in such a case, there is a disadvantage that the manufacturing cost increases as the thickness increases, and further, the thickness and weight of the display apparatus also increases.

[0005] Therefore, it is an aspect of the present invention to improve a strength of a chassis provided in a liquid crystal display apparatus while maintaining a relatively low manufacturing cost.

[0006] According to an aspect of an exemplary embodiment of the present invention, there is provided a liquid crystal display apparatus that includes a liquid crystal panel which is configured to display an image; a backlight unit which is configured to supply light for displaying the image on the liquid crystal panel; a top chassis and bottom chassis which package the liquid crystal panel and backlight unit in one module; and a strength reinforcing member which is mounted to an internal surface of the bottom chassis.

[0007] The strength reinforcing member may have a shape of a honeycomb having a plurality of cells.

[0008] Each cell of the strength reinforcing member may have a shape of a hexagonal column.

[0009] The strength reinforcing member may have a shape of a wave.

[0010] The strength reinforcing member may have a shape of an egg carton.

[0011] The strength reinforcing member may include a plurality of convex portions and a plurality of concave portions, and a concave portion may be placed between four convex portions and a convex portion may be placed between four concave portions.

[0012] The liquid crystal display apparatus may further include a cover member which covers the strength reinforcing member.

[0013] The strength reinforcing member may be at-

tached to the bottom chassis, and the cover member may be attached to the strength reinforcing member.

[0014] The strength reinforcing member and the bottom chassis may be attached by an adhesive, and the cover member and the strength reinforcing member may be attached by an adhesive.

[0015] The adhesive may be a hot melt adhesive.

[0016] The backlight unit may include at least one light source printed circuit board (PCB) on which a plurality of light sources are mounted, and the strength reinforcing member may be provided in a first area of the internal surface of the bottom chassis, and the at least one light source PCB may be attached to a second area of the internal surface of the bottom chassis which is not occupied by the strength reinforcing member.

[0017] A heat sink for transmitting heat generated by the light source to the bottom chassis may be provided between the light source PCB and bottom chassis.

[0018] The heat sink may be directly fastened to the top chassis.

[0019] The backlight unit may include at least one light source PCB on which a plurality of light sources are mounted, and the liquid crystal display apparatus may further include at least one heat sink that discharges heat generated by the light sources to outside, and the heat sink may be provided in a location to support the bottom chassis and light source PCB.

[0020] The heat sink may be directly fastened to the top chassis.

[0021] The liquid crystal display apparatus may further include a mid mold which assists mounting of the liquid crystal panel and backlight unit, and the heat sink may be directly fastened to the mid mold.

[0022] The strength reinforcing member may be made of aluminum.

[0023] The liquid crystal display apparatus may be applied to a large size television of 55 inches or more.

[0024] According to an aspect of another exemplary embodiment, there is provided a curved display apparatus that comprises a liquid crystal panel which is configured to display an image; a backlight unit which is configured to supply light for displaying the image on the liquid crystal panel; a top chassis and bottom chassis which package the liquid crystal panel and backlight unit in one module; and a strength reinforcing member which is attached to an internal surface of the bottom chassis.

[0025] The strength reinforcing member may have a shape of a honeycomb having a plurality of cells.

[0026] The above and/or other aspects will be more apparent by describing exemplary embodiments with reference to the accompanying drawings, in which:

FIG. 1 is a cross-sectional view illustrating a liquid crystal display apparatus according to a first exemplary embodiment;

FIG. 2 is an enlarged cross-sectional view of a right end portion of the liquid crystal display apparatus illustrated in FIG. 1;

FIG. 3 is a perspective view illustrating a bottom chassis and components mounted to the bottom chassis, provided in the liquid crystal display apparatus of FIG. 1;

FIG. 4 is a perspective view illustrating disassembled components of FIG. 3;

FIG. 5 is a perspective view illustrating a strength reinforcing member provided in the liquid crystal display apparatus of FIG. 1 according to an exemplary embodiment;

FIG. 6 is a perspective view illustrating a strength reinforcing member provided in the liquid crystal display apparatus of FIG. 1 according to another exemplary embodiment;

FIG. 7 is a similar view to FIG. 2, which illustrates a cross-sectional view of a liquid crystal display apparatus according to a second exemplary embodiment;

FIG. 8 is a similar view to FIG. 2, which illustrates a cross-sectional view of a liquid crystal display apparatus according to third exemplary embodiment;

FIG. 9 is a similar view to FIG. 2, which illustrates a cross-sectional view of a liquid crystal display apparatus according to fourth exemplary embodiment;

FIG. 10 is a cross-sectional view illustrating a liquid crystal display apparatus according to a fifth exemplary embodiment; and

FIG. 11 is an enlarged cross-sectional view of a right end portion of the liquid crystal display apparatus illustrated in FIG. 10.

[0027] Certain exemplary embodiments are described in more detail below with reference to the accompanying drawings.

[0028] FIG. 1 is a cross-sectional view illustrating a liquid crystal display apparatus according to a first exemplary embodiment, and FIG. 2 is an enlarged cross-sectional view of a right end portion of the liquid crystal display apparatus illustrated in FIG. 1.

[0029] With reference to FIGS. 1 and 2, the liquid crystal display (LCD) apparatus 100 is applicable to various liquid crystal display apparatuses, and more particularly to a large size display apparatus, for example a television of 55 inches or more. As illustrated in FIG. 1, the liquid crystal display apparatus 100 is a type of flat panel display apparatus.

[0030] As shown in FIG. 2, the liquid crystal display apparatus 100 includes a liquid crystal panel 110, backlight unit 120, top chassis 130, bottom chassis 140 and a mold 150.

[0031] The liquid crystal panel 110 is a component which displays an image, and includes an upper panel 111 and a lower panel 112. Between the upper panel 111 and the lower panel 112, there is placed liquid crystal (not illustrated). Although not illustrated, a front polarized filter and a color filter layer are provided in the upper panel 111, and a rear polarized filter and TFT array is provided in the lower panel 112.

[0032] According to a switching operation of the TFT

array, an arrangement of liquid crystal molecules corresponding to each pixel are adjusted, thereby displaying images from the liquid crystal panel 110. An operation principle of the liquid crystal panel 110 is known, and thus further explanation thereof is omitted.

[0033] The backlight unit 120 is for providing light for displaying images on the liquid crystal panel 110. Thus, the backlight unit 120 includes at least one light source printed circuit board (light source PCB) 121, a plurality of light sources 122 mounted to each light source printed circuit board 121, a light guide plate 123 placed at a rear side of the liquid crystal panel 110, a reflective sheet 124 which is placed at a rear side of the light guide plate 123, and a plurality of optical sheets 125 placed between the liquid crystal panel 110 and the light guide plate 123.

[0034] In the present exemplary embodiment, each of the light source PCBs 121 is placed on a right side and left side of the light guide plate 170 (see FIG. 1), and the plurality of light sources 122 provided in each of the light source PCB are placed to face an edge surface 123a of the light guide plate 123. For example, the light sources 122 may be provided as LEDs. The light discharged from the light sources 122 enter inside the light guide plate 123 through the edge surface 123a, and the entered light is guided to a front of the light guide plate 123 with the help of light emitting patterns (not illustrated) provided in a front surface or a rear surface of the light guide plate 123 and the reflective sheet 124 placed at a rear side of the light guide plate 123, and the guided light is provided to the liquid crystal panel 110 after the light is changed to have a further uniform brightness distribution by the optical sheets 125.

[0035] The light source PCB 121 is advantageously made of a metal material such as, for example aluminum, stainless steel, etc. of high thermal conductivity so that heat generated by the light sources 122 is well transmitted to the bottom chassis 140 which dissipates the heat and thus functions as a heat sink.

[0036] The structure of the backlight unit 120 explained hereinabove is merely an example, and thus the detailed structure of the backlight unit 120 according to other exemplary embodiments may be changed in various ways. In addition, the general structure of the backlight unit 120 is known, and thus further detailed explanation thereof is omitted. The top chassis 130 and bottom chassis 140 house the components of the liquid display apparatus 100 which include the liquid crystal panel 110 and backlight unit 120 explained hereinabove in one module. The mold 150 supports components of the liquid crystal panel 110 and optical sheets 125, etc., and assists the packing of the liquid crystal apparatus 100. Mold 150 may also be referred to as an intermediate mold or "mid" mold, on account of its position between the top chassis 130 and the bottom chassis 140.

[0037] The bottom chassis 140 has a coupling part 142 which is placed substantially orthogonally with respect to the liquid crystal panel 110 and backlight unit 120. Since the coupling part 142 is fastened to the top chassis

130 by a fastener such as a screw, the bottom chassis 140 is directly coupled to the top chassis 130. In other alternative exemplary embodiments, the top chassis 130 and bottom chassis 140 may be coupled to each other through the mid mold 150, and thus not directly coupled to each other. That is, the top chassis 130 and the bottom chassis 140 may be mutually connected to each other because each of the top chassis 130 and the bottom chassis 140 is independently connected to the mid mold 150.

[0038] The bottom chassis 140 also performs a function of discharging to the outside the heat generated by the light sources 122. That is, the bottom chassis 140 also functions as a heat sink for cooling the light sources 122. To this end, the bottom chassis 140 is advantageously made of a metal material of high heat conductivity, such as, for example, aluminum, stainless steel etc.

[0039] The bottom chassis 140 has a strength reinforcing member 160 mounted onto an internal surface 141 of the bottom chassis 140. The strength reinforcing member 160 is covered by a cover member 170. Herein, the strength reinforcing member 160 reinforces of the bottom chassis 140, making the bottom chassis 140 stronger thereby preventing deformation of the bottom chassis 140. By such a strength reinforcing member 160, the bottom chassis 140 becomes able to maintain a good flatness.

[0040] Referring to FIG. 3 and FIG. 4, the strength reinforcing member 160 and the cover member 170 will be described more detail.

[0041] FIG. 3 is a perspective view illustrating the bottom chassis, and components mounted to the bottom chassis, provided in the liquid crystal display apparatus of FIG. 1, and FIG. 4 is a perspective view illustrating disassembled components of FIG. 3.

[0042] With reference to FIGS. 3 and 4, the strength reinforcing member 160 is placed in a central portion of the bottom chassis 140. Therefore, the internal surface 141 of the bottom chassis 140 is divided into an occupied area 141a which is occupied by the strength reinforcing member 160 and a non-occupied area 141b which is not occupied by the strength reinforcing member 160. Herein, in FIG. 4, the occupied area 141a is expressed in virtual rectangular dotted lines, and a shape and size area of the occupied area 141a may change according to a shape and area of the strength reinforcing member 160. In the non-occupied area 141b, two light source PCBs 121 are mounted, and the strength reinforcing member 160 is provided therebetween. Thus, one light source PCB 121 is provided on each side of the strength reinforcing member 160. Note that alternatively there may be a plurality of light source PCBs 121, such that each side of the strength reinforcing member has multiple light source PCBs. On each of the light source PCBs 121, a plurality of light sources 122 are arranged.

[0043] The strength reinforcing member 160 is attached to the bottom chassis 140 by, for example, an adhesive such as a hot melt adhesive. As illustrated in

FIG. 4, the strength reinforcing member 160 has a plurality of cells 161, wherein each cell has a shape of a hexagonal column. Therefore, the strength reinforcing member 160 has an overall shape of a honeycomb. However, this is only an example, and in other alternative exemplary embodiments, a shape of each cell 161 may be changed to have other various shapes, for example other columnar shapes, for example, a tetragonal column shape or a cylindrical shape etc.

[0044] The strength reinforcing member 160 is made of aluminium, and may be advantageously made of aluminium with high strength. However, it is not limited thereto, and thus the strength reinforcing member 160 may be made of other metal materials or non-metal materials, such as, for example, plastic.

[0045] As such, the strength reinforcing member 160 having a shape of a honeycomb may be mounted to the bottom chassis 140, thereby significantly reinforcing of the bottom chassis 140 and improving the strength properties of the bottom chassis 140. Accordingly, the deformation of the bottom chassis 140 by weight, external force, or heat etc. may be minimized, so a good flatness of the bottom chassis 140 can be maintained. Thus, it is possible to prevent deterioration of the quality of images displayed by the liquid crystal panel 110 that would otherwise be caused by such deformation of the bottom chassis 140.

[0046] In addition, since the strength reinforcing member 160 does not increase the thickness of the bottom chassis 140 in order to achieve an improvement in the strength properties of the bottom chassis 140, and since the strength reinforcing member 160 is attached to the bottom chassis 140 relatively simply through an adhesive, it is possible to improve the strength properties of the bottom chassis 140 while maintaining a low manufacturing cost and high productivity.

[0047] Even when the liquid crystal display apparatus 100 is applied to a large size display apparatus, for example a television of 55 inches or more, it is possible to maintain a good flatness of the bottom chassis 140 by means of the aforementioned strength reinforcing member 160. In the case of such a large size display apparatus, the size area of the bottom chassis 140 becomes significantly large, and thus it is advantageous to prevent deformation of the bottom chassis 140 and maintain a good flatness thereof.

[0048] The cover member 170 covers the strength reinforcing member 160 so that the strength reinforcing member 160 is not exposed. Accordingly, the cover member 170 includes an upper portion 171 which covers the upper side of the strength reinforcing member 160 and a side portion 172 which covers the border of the strength reinforcing member 160. For example, the side portion 172 may be formed through a bending process. The cover member 170 may be made of a same material as the strength reinforcing member 160. Therefore, the cover member 170 may be made of, for example, aluminium. In addition, the cover member 170 is attached

to the strength reinforcing member 160, for example, by an adhesive such as hot melt.

[0049] Since the strength reinforcing member 160 is covered by the cover member 170, pollutants that may exist in the strength reinforcing member 160 and that may cause a deterioration in the performance of the liquid crystal display apparatus 100 may be prevented from entering the liquid crystal display apparatus 100. For example, particles generated during processing of or formation of the strength reinforcing member 160 may be examples of such a pollutant. Moreover, with reference to FIG. 2, the cover member 170 may also perform a function of supporting components such as the light guide plate 120 placed in its upper side.

[0050] FIG. 5 is a perspective view illustrating a strength reinforcing member provided in the liquid crystal display apparatus of FIG. 1 according to an alternative exemplary embodiment, and FIG. 6 is a perspective view illustrating a strength reinforcing member provided in the liquid crystal display apparatus of FIG. 1 according to another alternative exemplary embodiment.

[0051] With reference to FIG. 5, the alternative strength reinforcing member 160A is corrugated, also referred to as having an undulating or waved-shaped surface. More particularly, the strength reinforcing member 160A has a structure where convex portions 163 and concave portions 164 are repeated periodically. Herein, the convex portions 163 and concave portions 164 extend along a width direction or longitudinal direction of the strength reinforcing member 160A. That is, a concave portion 164 is placed between two convex portions 163, and a convex portion 163 is placed between two concave portions 164.

[0052] With reference to FIG. 6, another alternative strength reinforcing member 160B has a shape of an egg container, having a matrix of recessed portions or cells, divided by partitioning walls. More particularly, the strength reinforcing member 160B has a plurality of convex portions 165, corresponding to the partitioning walls, and a plurality of concave portions 166, corresponding to the recessed portions, which are repeated regularly in a two dimensional array, and a concave portion 166 is placed between four convex portions 165, and a convex portion 165 is placed between four concave portions 166.

[0053] In this disclosure, three strength reinforcing members 160, 160A, 160B having different shapes are introduced, but other strength reinforcing members having other shapes may be used as long as they contribute to improvement of a strength property of the bottom chassis 140.

[0054] FIG. 7 is a similar view to FIG. 2, which illustrates a cross-sectional view of a liquid crystal display apparatus according to a second exemplary embodiment.

[0055] The configuration of the liquid crystal display apparatus 100' illustrated in FIG. 7 is similar to the configuration of the liquid crystal display apparatus 100 illustrated in the aforementioned FIG. 1. However, in the case of the aforementioned liquid crystal display apparatus 100, the strength reinforcing member 160 is attached di-

rectly to the bottom chassis 140, whereas in the case of the liquid crystal display apparatus 100', there is a difference that the strength reinforcing member 160 is mounted to the bottom chassis 140 through an additional lower side cover member 175.

[0056] As such, the liquid crystal display apparatus 100' further includes a lower side cover member 175 in addition to the upper side cover member 170, and the strength reinforcing member 160 is surrounded by the upper side cover member 170 and the lower side cover member 175. In such a case, the lower side cover member 175, strength reinforcing member 160, and upper side cover member 170 may be attached sequentially on the bottom chassis 140, but the lower side cover member 175, strength reinforcing member 160, and upper side cover member 170 may also be mutually and individually bonded to each other first to form one strength reinforcing unit 101, and then bonded to the bottom chassis 140 at once by use of an adhesive, such as an adhesive tape or other such bonding method. The formation of one strength reinforcing unit 101, prior to bonding to the bottom chassis 140, has an advantage of simplifying the manufacturing process of the liquid crystal display apparatus 100'.

[0057] FIG. 8 is a similar view to FIG. 2, which illustrates a cross-sectional view of a liquid crystal display apparatus according to third exemplary embodiment.

[0058] With reference to FIG. 8, an alternative liquid crystal display apparatus 100A is similar to the configuration of the liquid crystal display apparatus 100 illustrated in the aforementioned FIG. 1. Especially, the alternative liquid crystal display apparatus 100A is similar to the liquid crystal display apparatus 100 of FIG. 1 in that a strength reinforcing member 160 for strength reinforcement is mounted to the bottom chassis 140A.

[0059] The difference of the liquid crystal display apparatus 100A from the aforementioned liquid crystal display apparatus 100 is that the liquid crystal display apparatus 100A further includes a heat sink 180 placed between a light source PCB 121 and the bottom chassis 140A. The heat sink 180 is made of a material, for example, aluminium, having a high thermal conductivity, to further effectively deliver the heat generated by the light sources 122 to the bottom chassis 140A.

[0060] Such a heat sink 180 includes a body part 181 which supports the light source PCB 121 and a coupling part 182 substantially orthogonal to the body part 181. The coupling part 182 is fastened to the top chassis 130 by a fastener, thereby being directly coupled to the top chassis 130. In other alternative exemplary embodiments, the heat sink 180 may be alternatively directly coupled to the mid mold 150.

[0061] FIG. 9 is a similar view to FIG. 2, which illustrates a cross-sectional view of a liquid crystal display apparatus according to fourth exemplary embodiment.

[0062] With reference to FIG. 9, another alternative liquid crystal display apparatus 100B is also similar to the aforementioned liquid crystal display apparatus 100 il-

lustrated in FIG. 1. Specifically, the liquid crystal display apparatus 100B is similar to the liquid crystal display apparatus 100 of FIG. 1 in that a strength reinforcing member 160 for strength reinforcement is mounted to a bottom chassis 140B.

[0063] The difference of the liquid crystal display apparatus 100B from the aforementioned liquid crystal display apparatus 100 is that the liquid crystal display apparatus 100B further includes a heat sink 190 placed at a rear side of the bottom chassis 140B. The heat sink 190 is made of a material, for example, aluminum, having a high thermal conductivity, to further effectively deliver the heat generated by the light sources 122 to the outside.

[0064] Such a heat sink 190 includes a body part 191 and a coupling part 192. The body part 191 supports not only a light source PCB 121 but also the bottom chassis 140B. Since the light source PCB 121 is not supported by the bottom chassis 140B directly, compared to other exemplary embodiments, the size (e.g., the width in the right to left direction in FIG. 1, or the area, etc.) of the bottom chassis 140B may be reduced. For example, the width of the bottom chassis 140B may be reduced to be the same as the width of the cover member 170. Moreover, since the coupling part 192 is fastened to the top chassis 130 by a fastener (not illustrated) such as a screw, the heat sink 190 may be directly coupled to the top chassis 130. In alternative exemplary embodiments, the heat sink 190 may be alternatively directly fastened to the mid mold 150.

[0065] FIG. 10 is a cross-sectional view illustrating a liquid crystal display apparatus according to a fifth exemplary embodiment, and FIG. 11 is an enlarged cross-sectional view of a right end portion of the liquid crystal display apparatus illustrated in FIG. 10.

[0066] With reference to FIGS. 10 and 11, the liquid crystal display apparatus 200 according to a fifth exemplary embodiment is a curved display apparatus, unlike the aforementioned liquid crystal display apparatuses.

[0067] Compared to the liquid crystal display apparatus 100 (see FIGS. 1 and 2) according to the first exemplary embodiment, the detailed configuration of the liquid crystal panel 110, the backlight unit 120, the top chassis 130, the bottom chassis 140, the mid mold 150, and the strength reinforcing member 160 of the liquid crystal display apparatus 200 are provided in substantially the same manner as those of the aforementioned liquid crystal display apparatuses 100, but since the liquid crystal display apparatus 200 is a curved surface display with a curvature, the liquid crystal panel 110, the backlight unit 120, the top chassis 130, the bottom chassis 140, the mid mold 150, and the strength reinforcing member 160 of the liquid crystal display apparatus 200 are formed to conform to such a curvature.

[0068] As discussed above, in the fifth exemplary embodiment, the bottom chassis 140 of the liquid crystal display apparatus 200 is also formed to conform to such a curvature. It is thus advantageous for the bottom chassis 140 to have good strength performance and proper-

ties so as to maintain the curvature.

[0069] Various methods may be applied to manufacture the liquid crystal display apparatus 200 in a curved shape. For example, a manufacturing method may be used where, after manufacturing a bottom chassis 140 of a curved surface shape, a top chassis 130 of a non-curved surface shape is assembled to the bottom chassis 140, thereby having other components such as the top chassis 130, etc. to conform to the curvature of the bottom chassis 140. In such a method, if the strength of the bottom chassis 140 is not sufficient, it may be difficult to maintain the curved surface shape of the liquid crystal display apparatus 200, and thus good strength performance of the bottom chassis 140 is advantageous.

[0070] Accordingly, a strength reinforcing member 160 of a honeycomb shape is mounted to the internal surface of the bottom chassis 140. As aforementioned, the strength of the bottom chassis 140 where the strength reinforcing member 160 of a honeycomb shape is attached may be reinforced significantly, and accordingly, even when a weight, external force, or heat, etc. are applied to the liquid crystal display apparatus 200, the liquid crystal display apparatus 200 may maintain the initial curvature with stability. Therefore, it is possible to prevent the quality of the images provided by the liquid crystal display apparatus 200 from being deteriorated due to deformation of the bottom chassis 140 from the original manufactured curvature.

[0071] The fifth exemplary embodiment was described as having a strength reinforcing member 160 having a honeycomb shape as the shape of the strength reinforcing member 160, but as aforementioned, a wave shape, or egg carton shape, etc. may also be applied as an alternative shape of the strength reinforcing member 160.

[0072] As aforementioned, according to the present invention, a strength reinforcing member may be mounted to a bottom chassis, to significantly improve the strength of the bottom chassis, thereby minimizing deformation of the bottom chassis due to weight, external force, and heat, etc. Therefore, in a case where the present invention is applied to a flat panel display apparatus, it is possible to maintain a good flatness of the flat panel display apparatus, and in a case where the present invention is applied to the curved display apparatus, it is possible to maintain the initial curvature with stability. Consequently, it is possible to prevent deterioration, caused by excessive deformation of the bottom chassis, of the quality of the images that the display apparatus provides.

[0073] In the case of a large size liquid crystal display apparatus, for example, a television of 55 inches or more, the area of the bottom chassis also increases, and thus it becomes advantageous to prevent deformation of the bottom chassis. Therefore, the liquid crystal display apparatus according to the present invention may be applied to such a large size display apparatus particularly advantageously.

[0074] Although a few embodiments of the present in-

vention have been shown and described, it would be appreciated by those skilled in the art that changes may be made to these exemplary embodiments without departing from the invention, the scope of which is defined in the claims.

Claims

1. A liquid crystal display apparatus comprising:

a liquid crystal panel which displays an image;
a backlight unit which provides light for displaying an image on the liquid crystal panel;
a top chassis and bottom chassis for packaging the liquid crystal panel and backlight unit in one module; and
a strength reinforcing member which is mounted to an internal surface of the bottom chassis for reinforcing a strength of the bottom chassis.

2. The liquid crystal apparatus according to claim 1, wherein the strength reinforcing member contains a two-dimensional array of cells, bounded by partitioning walls.

3. The liquid crystal display apparatus according to claim 2, wherein each cell of the strength reinforcing member has a shape of a hexagonal column, so that the strength reinforcing member has the shape of a honeycomb.

4. The liquid crystal display apparatus according to claim 2, wherein the strength reinforcing member has a shape of an egg carton.

5. The liquid crystal display apparatus according to claim 4, wherein the strength reinforcing member comprises a plurality of convex portions and a plurality of concave portions, and wherein a concave portion is placed between four convex portions and a convex portion is placed between four concave portions.

6. The liquid crystal display apparatus according to claim 1, wherein the strength reinforcing member is corrugated.

7. The liquid crystal display apparatus according to any one of the preceding claims, further comprising a cover member which covers the strength reinforcing member.

8. The liquid crystal display apparatus according to any one of claims 1 to 7, wherein the backlight unit comprises at least one light source printed circuit board (PCB) where a plurality of light sources are mounted, and

wherein the strength reinforcing member occupies a partial area of the internal surface of the bottom chassis, and the at least one light source PCB is mounted to an area of the internal surface of the bottom chassis which is not occupied by the strength reinforcing member.

9. The liquid crystal display apparatus according to claim 8, wherein a heat sink for transmitting heat generated by the light sources to the bottom chassis is placed between the light source PCB and bottom chassis.

10. The liquid crystal display apparatus according to claim 9, wherein the heat sink is directly fastened to the top chassis.

11. The liquid crystal display apparatus according to any one of claims 1 to 7, wherein the backlight unit comprises at least one light source printed circuit board (PCB) where a plurality of light sources are mounted, and the liquid crystal display apparatus further comprises at least one heat sink for discharging heat generated by the light source to outside, and wherein the heat sink is placed to support the bottom chassis and light source PCB.

12. The liquid crystal display apparatus according to claim 11, wherein the liquid crystal display apparatus further comprises a mold which assists mounting of the liquid crystal panel and backlight unit, and the heat sink is directly fastened to the mid mold.

13. The liquid crystal display apparatus according to any one of the preceding claims, wherein the strength reinforcing member is made of aluminium.

14. A curved display apparatus which is provided as a liquid crystal display apparatus according to any one of claims 1 to 13.

15. The liquid crystal display apparatus according to any one of the preceding claims, wherein the liquid crystal display apparatus is applied to a large size television of 55 inches or more.

FIG. 1

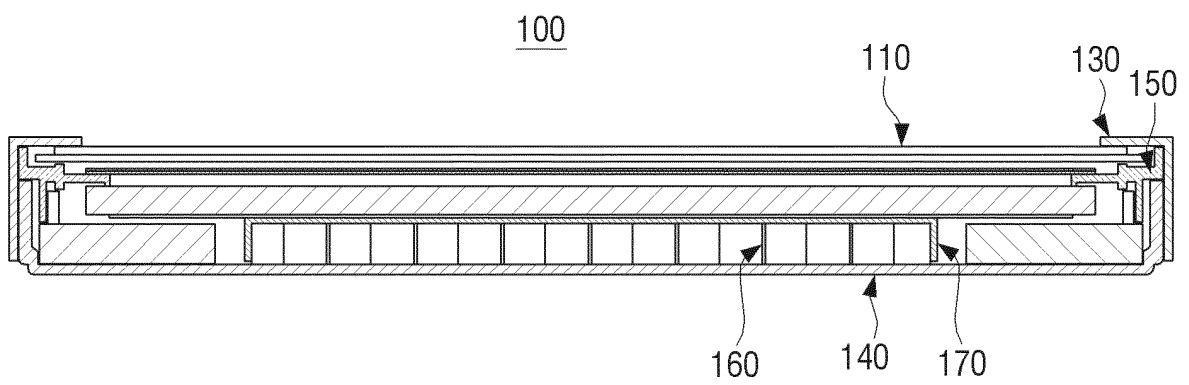

FIG. 2

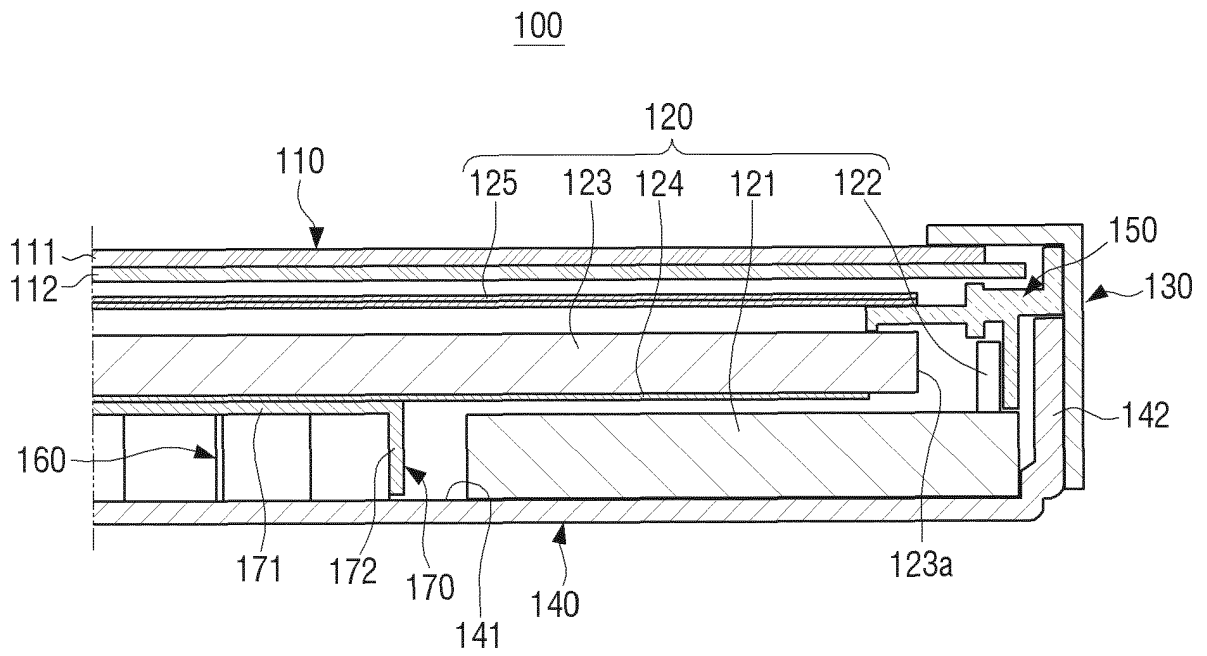

FIG. 3

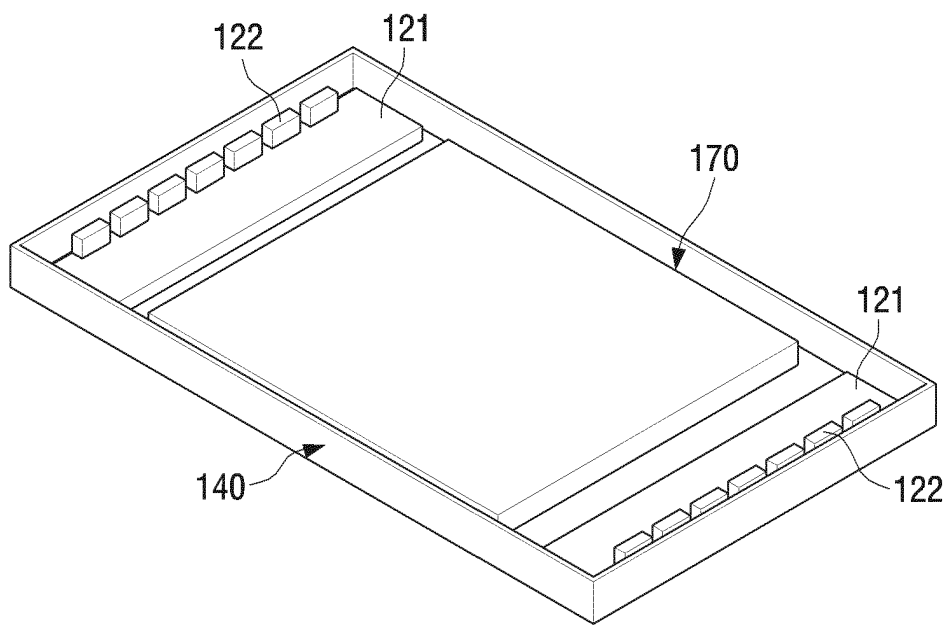

FIG. 4

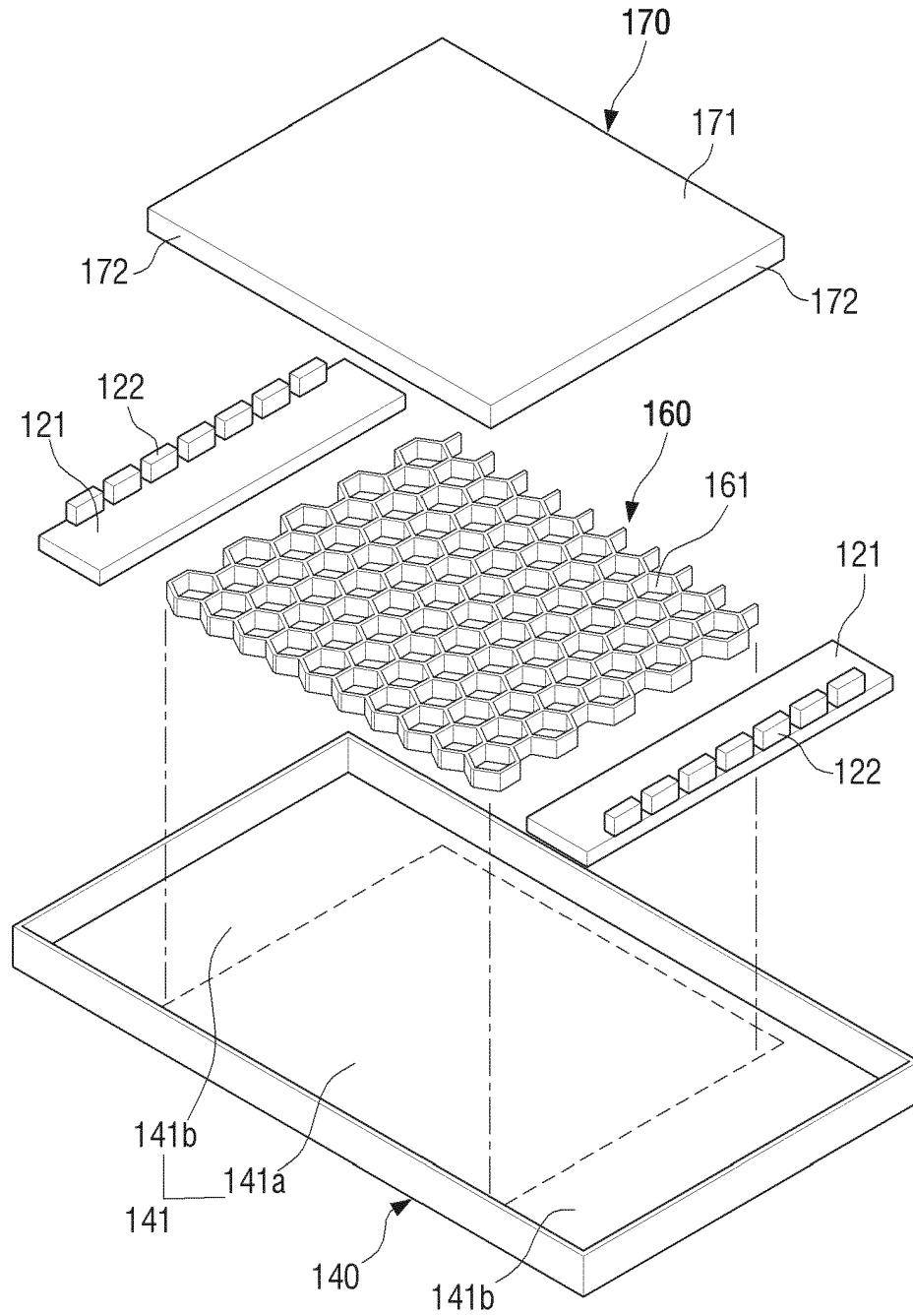

FIG. 5

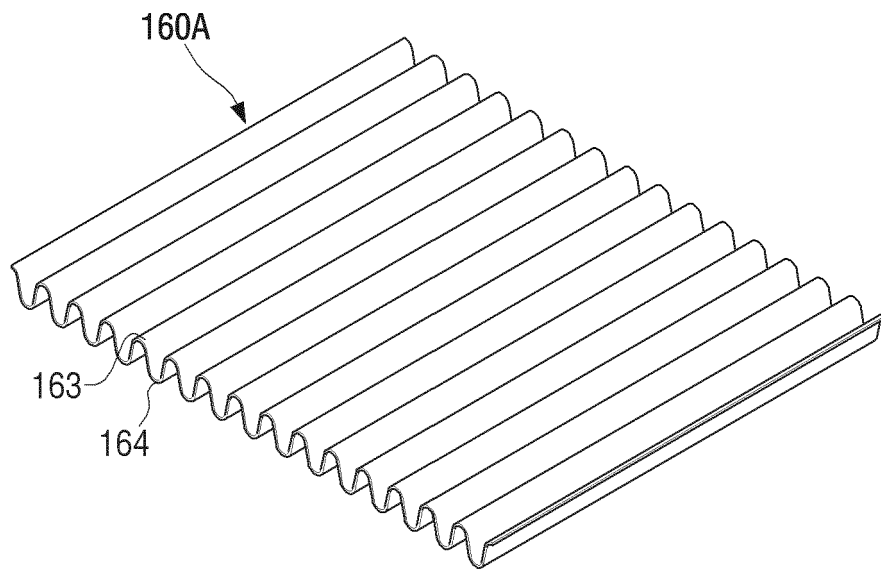

FIG. 6

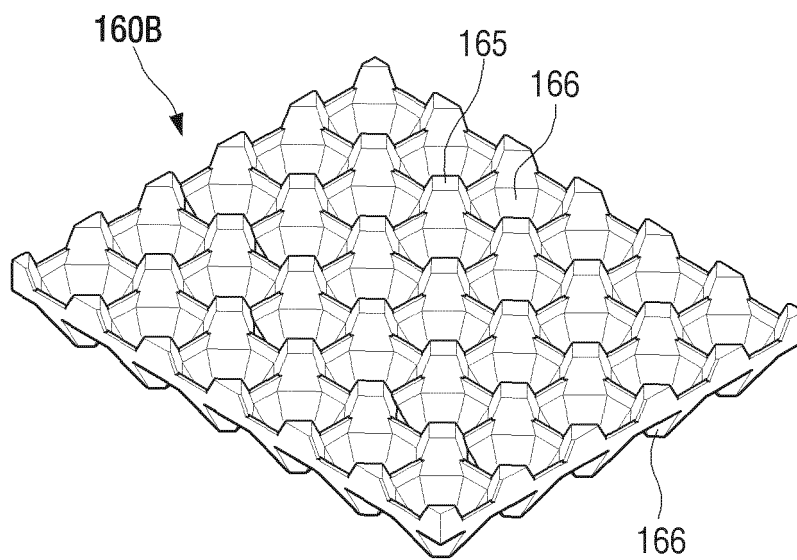

FIG. 7

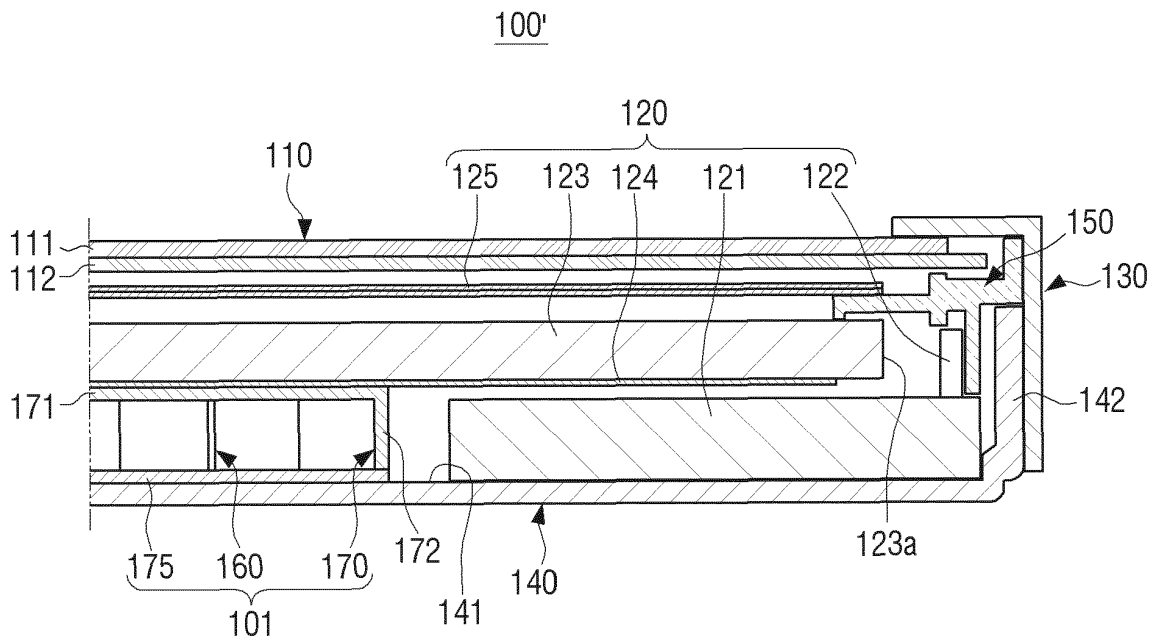

FIG. 8

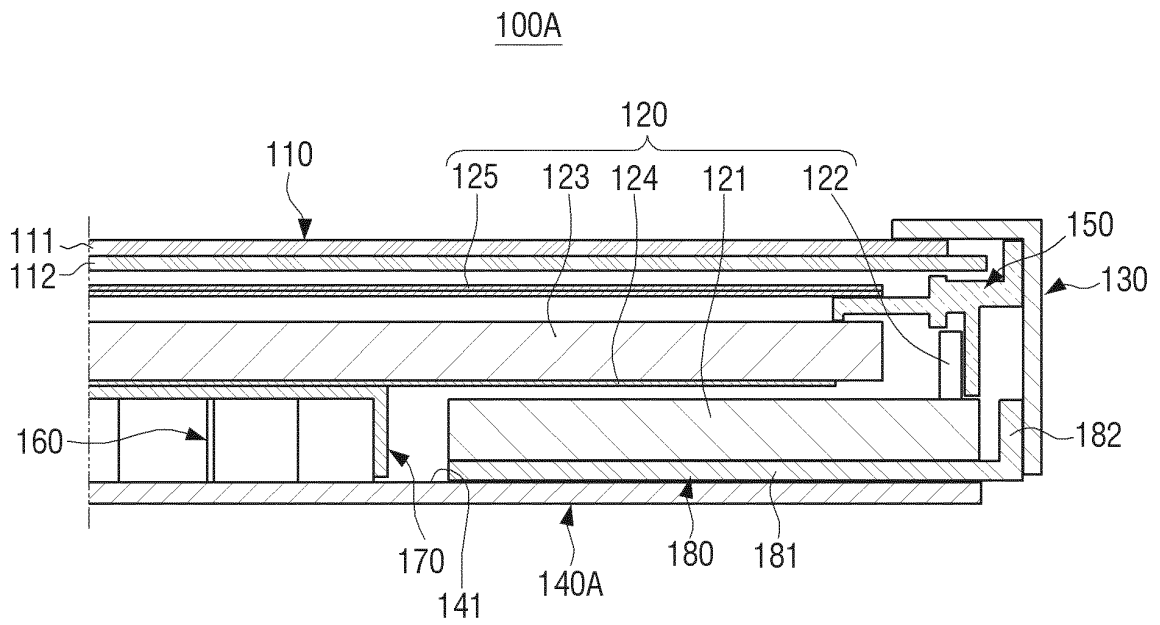

FIG. 9

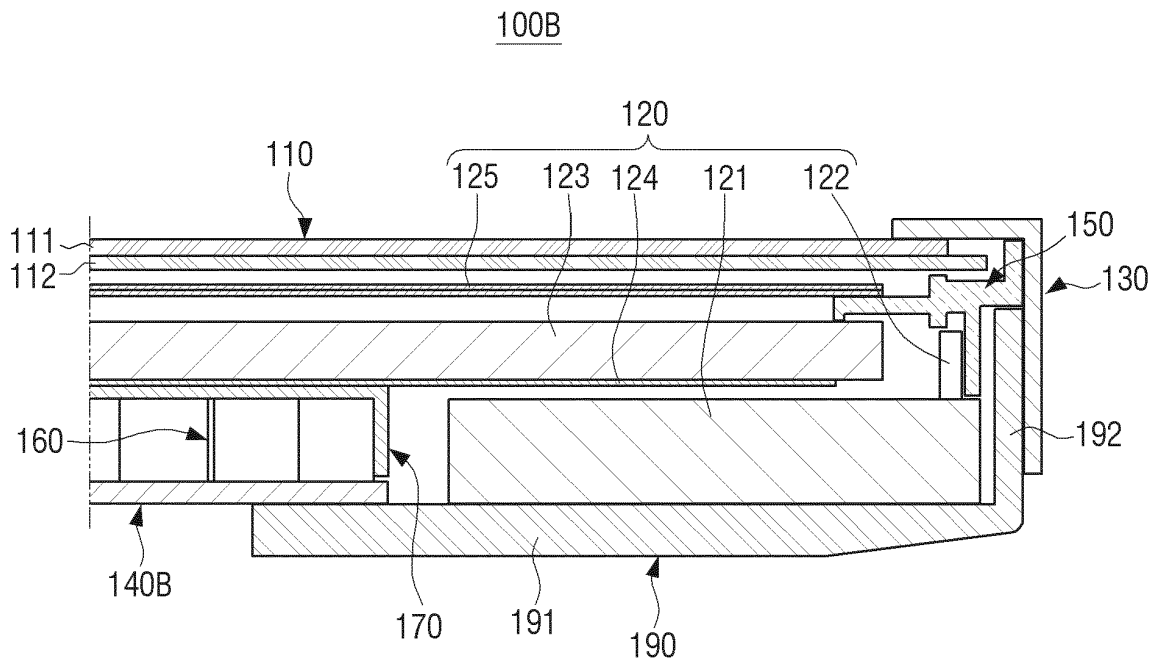

FIG. 10

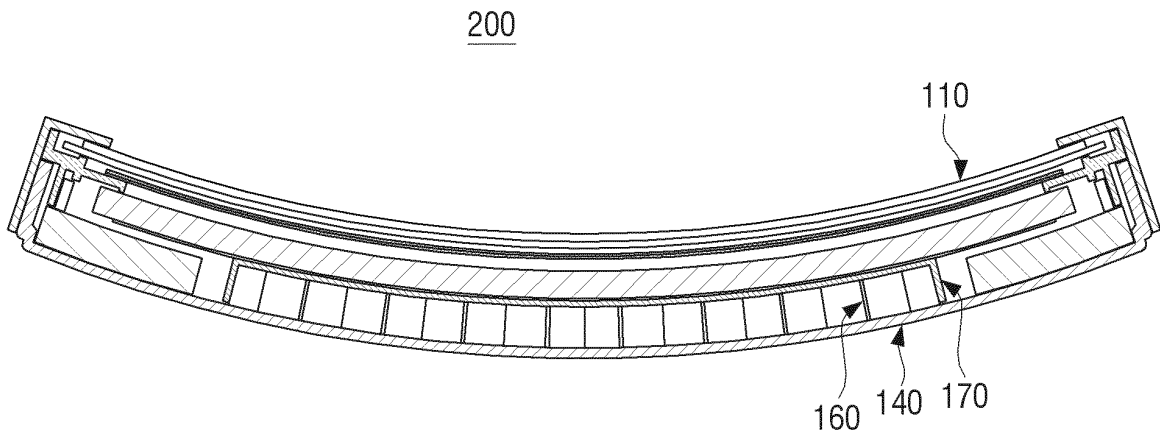
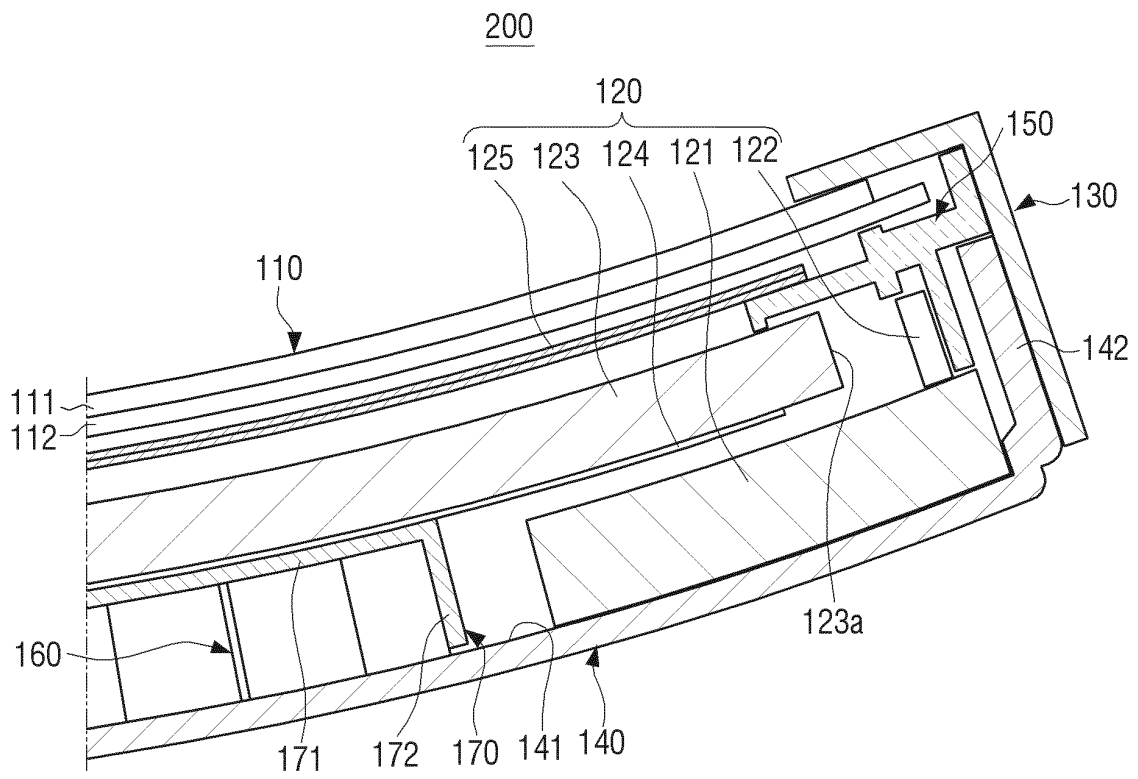

FIG. 11





EUROPEAN SEARCH REPORT

Application Number
EP 13 16 8931

DOCUMENTS CONSIDERED TO BE RELEVANT			
Category	Citation of document with indication, where appropriate, of relevant passages	Relevant to claim	CLASSIFICATION OF THE APPLICATION (IPC)
X	JP 2008 288047 A (SHARP KK) 27 November 2008 (2008-11-27)	1-3,7, 13,15	INV. G02F1/1333 F21V8/00
Y	* abstract * * figures 1-4 *	4-6,14	
Y	----- US 2001/012812 A1 (SPENGLER ERNST MAXIMILIAN [DE]) 9 August 2001 (2001-08-09) * figures 4-12 * * paragraph [0036] - paragraph [0055] *	4,5	
Y	----- JP 2008 276035 A (SEIKO EPSON CORP) 13 November 2008 (2008-11-13) * figures 2, 8 * * abstract *	6	
Y	----- US 2009/316062 A1 (NISHIZAWA SHIGEKI [JP]) 24 December 2009 (2009-12-24) * figure 1 *	14	
Y	----- US 2011/090426 A1 (CHOI JAE-CHANG [KR] ET AL) 21 April 2011 (2011-04-21) * figures 1-7 * * paragraph [0035] - paragraph [0069] *	1-3, 11-13	TECHNICAL FIELDS SEARCHED (IPC) G02F G02B
Y	----- WO 2011/024254 A1 (FUJITSU LTD [JP]; AOKI SHINJI [JP]) 3 March 2011 (2011-03-03) * figures 8,20 *	1-3, 11-13	
E	----- EP 2 610 667 A1 (SAMSUNG ELECTRONICS CO LTD [KR]) 3 July 2013 (2013-07-03) * figures 1-8 * * paragraph [0033] - paragraph [0154] *	1-3,7,13	
The present search report has been drawn up for all claims			
Place of search Munich		Date of completion of the search 7 August 2013	Examiner Kentischer, Florian
CATEGORY OF CITED DOCUMENTS X : particularly relevant if taken alone Y : particularly relevant if combined with another document of the same category A : technological background O : non-written disclosure P : intermediate document		T : theory or principle underlying the invention E : earlier patent document, but published on, or after the filing date D : document cited in the application L : document cited for other reasons & : member of the same patent family, corresponding document	

2
EPO FORM 1503 03.82 (P04C01)

ANNEX TO THE EUROPEAN SEARCH REPORT
ON EUROPEAN PATENT APPLICATION NO.

EP 13 16 8931

This annex lists the patent family members relating to the patent documents cited in the above-mentioned European search report. The members are as contained in the European Patent Office EDP file on The European Patent Office is in no way liable for these particulars which are merely given for the purpose of information.

07-08-2013

Patent document cited in search report	Publication date	Patent family member(s)	Publication date
JP 2008288047 A	27-11-2008	JP 4722082 B2 JP 2008288047 A	13-07-2011 27-11-2008
US 2001012812 A1	09-08-2001	DE 20001729 U1 US 2001012812 A1	21-06-2001 09-08-2001
JP 2008276035 A	13-11-2008	NONE	
US 2009316062 A1	24-12-2009	JP 2010002487 A US 2009316062 A1	07-01-2010 24-12-2009
US 2011090426 A1	21-04-2011	CN 102042542 A JP 2011086627 A KR 20110042574 A US 2011090426 A1	04-05-2011 28-04-2011 27-04-2011 21-04-2011
WO 2011024254 A1	03-03-2011	NONE	
EP 2610667 A1	03-07-2013	CN 103187009 A EP 2610667 A1 US 2013170116 A1	03-07-2013 03-07-2013 04-07-2013

EPO FORM P0459

For more details about this annex : see Official Journal of the European Patent Office, No. 12/82

专利名称(译)	液晶显示装置		
公开(公告)号	EP2667247A1	公开(公告)日	2013-11-27
申请号	EP2013168931	申请日	2013-05-23
[标]申请(专利权)人(译)	三星电子株式会社		
申请(专利权)人(译)	三星电子有限公司		
当前申请(专利权)人(译)	三星电子有限公司		
[标]发明人	AHN JOON SEOK PARK JAE HYUN		
发明人	AHN, JOON-SEOK PARK, JAE-HYUN		
IPC分类号	G02F1/1333 F21V8/00		
CPC分类号	G02F1/133608 G02B6/0085 G02B6/0093 G02F1/133308 G02F2001/133314 G02F2201/50 G02F2201/503		
优先权	1020120127641 2012-11-12 KR 1020120056184 2012-05-25 KR		
其他公开文献	EP2667247B1		
外部链接	Espacenet		

摘要(译)

提供液晶显示器 (100)。液晶显示器 (100) 包括液晶面板 (110)，其配置为显示图像;背光 (120)，用于提供用于在液晶面板 (110) 上显示图像的光;顶部机壳 (130) 和底部机壳 (140)，其将液晶面板 (110) 和背光单元 (120) 封装在一个模块中;强度加强件 (160) 安装在底架 (140) 的内表面 (141) 上，以增强底架 (140) 的强度。

FIG. 2

