

(19)



(11)

EP 2 192 440 B1

(12)

EUROPEAN PATENT SPECIFICATION

(45) Date of publication and mention of the grant of the patent:
23.01.2013 Bulletin 2013/04

(51) Int Cl.:
G02F 1/1345 (2006.01)

(21) Application number: **09008027.6**

(22) Date of filing: **19.06.2009**

(54) **Liquid crystal display**

Flüssigkristallanzeige

Affichage à cristaux liquides

(84) Designated Contracting States:
AT BE BG CH CY CZ DE DK EE ES FI FR GB GR HR HU IE IS IT LI LT LU LV MC MK MT NL NO PL PT RO SE SI SK TR

(30) Priority: **27.11.2008 KR 20080119142**

(43) Date of publication of application:
02.06.2010 Bulletin 2010/22

(73) Proprietor: **Samsung Display Co., Ltd. Yongin-City, Gyeonggi-Do (KR)**

(72) Inventor: **Lee, Sang-Duk Asan-si Chungcheongnam-do (KR)**

(74) Representative: **Weitzel, Wolfgang Patentanwalt Friedenstrasse 10 89522 Heidenheim (DE)**

(56) References cited:
EP-A1- 2 221 658 JP-A- 2001 194 645
US-A1- 2002 149 074 US-A1- 2003 043 104
US-A1- 2006 125 981 US-A1- 2007 046 884
US-A1- 2008 043 193

EP 2 192 440 B1

Note: Within nine months of the publication of the mention of the grant of the European patent in the European Patent Bulletin, any person may give notice to the European Patent Office of opposition to that patent, in accordance with the Implementing Regulations. Notice of opposition shall not be deemed to have been filed until the opposition fee has been paid. (Art. 99(1) European Patent Convention).

Description

[0001] This application claims priority to Korean Patent Application No. 10-2008-0119142 filed on November 27, 2008.

BACKGROUND OF THE INVENTION

1. Field of the Invention

[0002] The present invention relates to a liquid crystal display ("LCD"), and more particularly, to an LCD which can reduce the manufacturing cost thereof.

2. Description of the Related Art

[0003] Liquid crystal displays ("LCDs") include a first display panel including a plurality of pixel electrodes, a second display panel including a common electrode, and a liquid crystal panel including a dielectric-anisotropy liquid crystal layer interposed between the first and second display panels. An LCD may display desired images by generating an electric field between the plurality of pixel electrodes and the common electrode, and adjusting the intensity of the electric field so as to control the amount of light transmitted through the liquid crystal panel.

[0004] In a conventional LCD, the manufacturing cost of a data driving module is generally higher than that of a gate driving module, and a transistor of the data driving module is required to provide high mobility.

[0005] JP2001194645 discloses a liquid crystal display panel having a rectangular shape. On the panel, gate lines extend in parallel to the short sides of the liquid crystal display panel and data lines extend in parallel to the long sides of the liquid crystal display panel.

[0006] US2006/0125981 discloses a liquid crystal display comprising a liquid crystal panel having a rectangular shape, and comprising a printed circuit board which supplies an image to the liquid crystal panel and which is placed on a same level with the liquid crystal panel at one of the short side of the liquid crystal panel. The liquid crystal display also comprises a flexible circuit board on which light emitting diodes are mounted. The flexible circuit board is connected via a connector to a circuit film linking the liquid crystal panel and the printed circuit board.

BRIEF SUMMARY OF THE INVENTION

[0007] Since the manufacturing cost of a data driving module is generally higher than that of a gate driving module, and a transistor of the data driving module is required to provide high mobility to a liquid crystal display ("LCD"), there may be disadvantages in manufacturing the liquid crystal display. For example, it is difficult to directly form the data driving module on an insulating substrate as an integrated circuit ("IC"). In addition, as the number of data lines connected to each data driving

module increases, the number of data driving modules required to manufacture an LCD increases, and thus, the manufacturing cost increases considerably. Therefore, in order to reduce the manufacturing cost, an LCD capable of reducing the number of data driving modules and/or the number of data lines is needed. Exemplary embodiments of the present invention provide a liquid crystal display ("LCD") which can reduce the manufacturing cost.

[0008] The invention is defined by the appended claims.

BRIEF DESCRIPTION OF THE DRAWINGS

BRIEF DESCRIPTION OF THE DRAWINGS

[0009] The above and other aspects and features of the present invention will become more apparent by describing in detail exemplary embodiments thereof with reference to the attached drawings, in which:

FIG. 1 illustrates a front view and side views of a liquid crystal display ("LCD") according to a first exemplary embodiment of the present invention;

FIG. 2 illustrates an exemplary embodiment of a rear view of the LCD shown in FIG. 1;

FIG. 3 illustrates an exploded perspective view of the LCD shown in FIG. 1;

FIG. 4A illustrates a plan view of an exemplary embodiment of a liquid crystal panel shown in FIG. 3;

FIG. 4B illustrates a layout of an exemplary embodiment of a pixel array of the liquid crystal panel shown in FIG. 4A;

FIG. 4C illustrates an exemplary embodiment of an equivalent circuit diagram of the pixel array shown in FIG. 4B;

FIGS. 5A through 5C illustrate diagrams of alternative exemplary embodiments of the LCD shown in FIG. 1;

FIG. 6 illustrates a rear view of an LCD according to a second exemplary embodiment of the present invention;

FIG. 7A illustrates a front view and side views of an LCD according to a third exemplary embodiment of the present invention;

FIG. 7B illustrates an exemplary embodiment of a rear view of the LCD shown in FIG. 7A;

FIG. 8A illustrates a front view and side views of an LCD according to a fourth exemplary embodiment of the present invention;

FIG. 8B illustrates an exemplary embodiment of a rear view of the LCD shown in FIG. 8A;

FIG. 9A illustrates a front view and side views of an LCD according to an example not according to the present invention;

FIG. 9B illustrates a rear view of the LCD shown in FIG. 9A;

FIG. 10A illustrates a front view and side views of an

LCD according to an example not according to the present invention; and
 FIG. 10B illustrates a rear view of the LCD shown in FIG. 10A.

DETAILED DESCRIPTION OF THE INVENTION

[0010] The present invention will now be described more fully with reference to the accompanying drawings, in which exemplary embodiments of the invention are shown. The invention may, however, be embodied in many different forms and should not be construed as being limited to the embodiments set forth herein. Rather, these embodiments are provided so that this disclosure will be thorough and complete, and will fully convey the concept of the invention to those skilled in the art.

[0011] Hereinafter, the present invention will be described in detail with reference to the accompanying drawings.

[0012] A liquid crystal display ("LCD") according to an exemplary embodiment of the present invention will hereinafter be described in detail with reference to FIGS. 1 through 4C.

[0013] FIG. 1 illustrates a front view and side views of an LCD 100 according to a first exemplary embodiment of the present invention, FIG. 2 illustrates an exemplary embodiment of a rear view of the LCD 100, and FIG. 3 illustrates an exploded perspective view of the LCD 100.

[0014] Referring to FIGS. 1 through 3, the LCD 100 includes a liquid crystal panel assembly 120, a backlight assembly 190 and an upper container 110.

[0015] The liquid crystal panel assembly 120 includes a liquid crystal panel 123, a chip film package 126 and a printed circuit board ("PCB") 128.

[0016] The liquid crystal panel 123 includes a lower display panel 122 including a plurality of gate lines, a plurality of data lines, a thin-film transistor ("TFT") array and a plurality of pixel electrodes, an upper display panel 124 facing the lower display panel 122, and a liquid crystal layer (not shown) interposed between the lower display panel 122 and the upper display panel 124.

[0017] The liquid crystal panel 123 is substantially rectangular in planar shape, and may display image data. In a layout view, the gate lines extend substantially vertically in a first direction and substantially parallel with the short (e.g., transverse) sides of the liquid crystal panel 123. In the layout view, the data lines extend substantially horizontally in a second direction and substantially parallel with the long (e.g., longitudinal) sides of the liquid crystal panel 123. The first and the second direction may be inclined relative to each other, such as being substantially perpendicular to each other. The short sides of the liquid crystal panel 123 may correspond to the left and right sides of a viewing direction from which a viewer watches the LCD 100, and the long sides of the liquid crystal panel 123 may correspond to the upper and lower sides of the viewing direction. However, the present invention is not restricted thereto.

[0018] The chip film package 126 may be a data driving module. The chip film package 126 may be disposed on a first side (e.g., the left side or transverse side) of the liquid crystal panel 123, may be connected to the data lines disposed on the lower display panel 122, and may provide a data driving signal to the data lines. The chip film package 126 may include a wiring pattern obtained by disposing a semiconductor chip on a flexible film and a tape-automated bonding ("TAB") tape. In one exemplary embodiment, a tape carrier package ("TCP") or a chip-on-film ("COF") may be used as the chip film package 126, but the present invention is not restricted thereto.

[0019] A gate driving module (not shown) may be connected to the gate lines disposed on the lower display panel 122 and may provide a gate driving signal to the gate lines. The gate driving module may be disposed on the lower display panel 122 as an integrated circuit. In one exemplary embodiment, the gate driving module may be disposed on the upper or lower side of the lower display panel 122, in the layout view, such as to be disposed at a side of the liquid crystal panel 123 adjacent to the side where the chip film package 126 is disposed. The gate driving module may be formed during the formation of a TFT array. However, the present invention is not restricted thereto. In an exemplary embodiment, the gate driving module may be formed in substantially the same shape as the chip film package 126.

[0020] Since the chip film package 126 is disposed near one of the short sides of the liquid crystal panel 123 so as to be connected to the data lines of the liquid crystal panel 123, the PCB 128, which is connected to the chip film package 126, is disposed near whichever of the short sides of the liquid crystal panel 123 is close to the chip film package 126. Various driving elements 129 for processing a gate driving signal to be input to the gate driving module and a data driving signal to be input to the chip film package 126 may be mounted on the PCB 128. The PCB 128 is connected to the liquid crystal panel 123 and provides image data to the liquid crystal panel 123.

[0021] In order to minimize an overall thickness of the LCD 100, the PCB 128 is disposed on a level with the liquid crystal panel 123. Referring to a side view of FIG. 1, an uppermost surface of the PCB 128 is substantially coplanar with an uppermost surface of the upper container 110 of the LCD 100. Similarly, a lowermost surface of the driving element 129 is disposed substantially coplanar with and not extending further than a lowermost surface of the upper container 110 of the LCD 100.

[0022] Referring to FIG. 2, the PCB 128 is connected to an external controller (not shown) through a film module 186, and may be provided with various signals for displaying an image by the external controller. In the illustrated embodiment, a first connector 182 is disposed on a bottom surface of the PCB 128, and is electrically and physically connected to the film module 186. In order to reduce an overall size (e.g., dimension) of the LCD

100, a width of the PCB 128, taken in a direction substantially perpendicular to a longitudinal direction of the PCB 128, may be reduced. In the illustrated embodiment, if a width of the film module 186, taken in a direction substantially perpendicular to a longitudinal direction of the film module 186, is greater than the width of the PCB 128, a connection terminal of the first connector 182 may be arranged to face the liquid crystal panel 123. As shown in FIG. 2, the film module 186 is coupled to the first connector 182 by being moved in a direction substantially perpendicular to the short sides of the liquid crystal panel 123. The film module 186 may be bent in an L-shape in the layout view.

[0023] The backlight assembly 190 includes a mold frame 130, a plurality of an optical sheet 140, a light guide plate 150, a reflective sheet 160, a light source module 177 and a lower container 170.

[0024] The light guide plate 150 guides light provided to the liquid crystal panel 123 by the light source module 177. The light guide plate 150 may be substantially plate-shaped (e.g., planar) and include a transparent plastic material, and may be able to efficiently transmit light. In one exemplary embodiment, the light guide plate 150 may include of an acrylic resin, such as polymethyl methacrylate ("PMMA") or polycarbonate. When light incident upon one or more of a side surface of the light guide plate 150 arrives at the top or bottom of the light guide plate 150 at an angle greater than the critical angle of the light guide plate 150 by passing through the light guide plate 150, the light is essentially totally reflected from the respective top or bottom of the light guide plate 150, and is uniformly distributed throughout the whole light guide plate 150, instead of being emitted from the light guide plate 150. As used herein, top and bottom may refer to a front or viewing side of the LCD 100, and a rear side of the LCD 100, respectively.

[0025] A plurality of diffusion patterns (not shown) may be disposed on at least one of the top or bottom of the light guide plate 150 in order to emit light reflected within the light guide plate 150 toward the liquid crystal panel 123, which is disposed above the light guide plate 150 towards the viewing side of the LCD 100. In one exemplary embodiment, the diffusion patterns may be disposed on the bottom of the light guide plate 150. Light reflected within the light guide plate 150 may be reflected by the diffusion patterns and may be emitted toward the outside of the light guide plate 150 through the top surface (e.g., light emitting surface) of the light guide plate 150.

[0026] In order to substantially uniformly maintain the luminance of light emitted from the light guide plate 150, the size and/or density of the diffusion patterns may vary according to the distance from the light source module 177. In one exemplary embodiment, the size and/or density of the diffusion patterns may increase as the distance from the light source module 177 increases, thereby substantially uniformly maintaining the luminance of light emitted from the light guide plate 150. The diffusion patterns may be formed using a silk-screen printing method,

but the present invention is not restricted thereto. In an alternative embodiment, a plurality of grooves or protrusions may be disposed on the light guide plate 150, thereby obtaining the benefits of the diffusion patterns.

[0027] The light source module 177 may be disposed on one or more of a side of the light guide plate 150. In the layout view of FIGS. 1 and 2, the light source module 177 may be disposed below the light guide plate, and particularly, along a lower side of the LCD 100 which is a longitudinal side of the LCD 100. In the side view of FIG. 1, the light source module 177 is disposed at a side of the light guide plate 150. In the illustrated embodiment, the light guide plate 150 may be formed as a substantially flat plate having a substantially uniform thickness in order to uniformly distribute light throughout an entire display screen, but the present invention is not restricted thereto. Alternatively, the light guide plate 150 may be formed in various shapes other than that set forth herein. The light source module 177 includes a circuit board 176 on which circuit patterns are disposed, and a plurality of a light source unit 178 each of which is mounted on the circuit board 176. The light source units 178 generate light to be provided to the light guide plate 150.

[0028] Each of the light source units 178 may include a light-emitting element. In exemplary embodiments, light-emitting diodes ("LEDs"), incandescent bulbs, or white halogen lamps may be used as the light source units 178. Preferably, LEDs, which have excellent color representation capability and consume less power, may be used as the light source units 178. Each of the light source units 178 may include a frame (not shown), and red, green and blue light-emitting chips (not shown) installed in the frame. Red light, green light and blue light emitted from the red, green and blue light-emitting chips, respectively, may be mixed, thereby generating white light.

[0029] Referring to FIGS. 2 and 3, a first portion of the circuit board 176 is disposed between the lower container 170 and the light guide plate 150, and the light source units 178 are mounted on the first portion of the circuit board 176. A second portion of the circuit board 176 extends from an inner portion of the lower container 170 to along an outer surface of a rear of the lower container 170 through an opening (not shown) disposed at a bottom portion of the lower container 170. An end of the circuit board 176 is connected to the PCB 128 at the rear of LCD 100, as illustrated in FIG. 2. The end of the circuit board 176 is connected to a second connector 184 disposed on a bottom of the PCB 128. A connection terminal of the second connector 184, like the connection terminal of the first connector 182, is arranged to face the liquid crystal panel 123. In the illustrated embodiment, the circuit board 176 is coupled to the second connector 184 by being moved in a direction substantially perpendicular to the short sides of the liquid crystal panel 123. An entire of the circuit board 176 disposed at the rear of the LCD 100 overlaps portions of the lower container 170 and the PCB 128.

[0030] If the circuit board 176 of the light source module 177 and the film module 186 overlap each other, signal interference may occur. In the illustrated embodiment, the second connector 184 is disposed closer to the light source module 177 than the first connector 182 to the light source module 177, in order to reduce or effectively prevent the circuit board 176 and the film module 186 from overlapping each other. The second portion of the circuit board 176 and the film module 186 do not overlap each other at the rear side of the LCD 100. Therefore, the second connector 184 is located lower than the first connector 182 on the PCB 128, as shown in the layout view of FIG. 2.

[0031] Referring again to FIG. 3, the optical sheets 140 may be disposed above the light guide plate 150 on a viewing side of the LCD 100. The optical sheets 140 may diffuse and collect light transmitted by the light guide plate 150. In an exemplary embodiment, the optical sheets 140 may include a diffusion sheet, one or more prism sheets and/or a protective sheet. The diffusion sheet may be disposed between the light guide plate 150 and the prism sheet and may diffuse light incident thereupon from the light guide plate 150, thereby reducing or effectively preventing the light from being concentrated in certain areas. A plurality of triangular prisms may be substantially uniformly disposed on the top of each of the prism sheets. More specifically, the optical sheets 140 may include two prism sheets. Where the optical sheets 140 include more than one prism sheet, the direction in which a plurality of prisms are arranged on one prism sheet may form a predetermined angle with the direction in which a plurality of prisms are arranged on another of the prism sheets. The prism sheets may collect light diffused by the diffusion sheet and may enable the collected light to be substantially perpendicularly incident upon the liquid crystal panel 123. Therefore, light transmitted through the prism sheets may travel substantially perpendicularly toward the liquid crystal panel 123, and the distribution of luminance on the protective sheet may become regular. The protective sheet may be disposed on the prism sheets, such as directly adjacent to the liquid crystal panel assembly 120, and may protect the prism sheets. In addition, the protective sheet may diffuse light and may provide a uniform distribution of light. The elements of the optical sheets 140 are not restricted to that set forth herein. The elements of the optical sheets 140 may change according to the structure of the LCD 100.

[0032] The reflective sheet 160 may be disposed below the light guide plate 150 towards the rear of the LCD 100, and may reflect light emitted from the bottom of the light guide plate 150 toward the light guide plate 150. The reflective sheet 160 may reflect light yet to be reflected by the diffusion patterns on the light guide plate 150 toward the light guide plate 150, thereby reducing light loss and improving the uniformity of light penetrated into the light guide plate 150. In an exemplary embodiment, the reflective sheet 160 may include polyethylene terephthalate ("PET"). One or more of a surface of the reflective

sheet 160 may be coated with a diffusion layer, such as including titanium dioxide. In one exemplary embodiment, if titanium dioxide is dried and fixed onto the reflective sheet 160, a frost-like white layer may be formed on the reflective sheet 160, such that the reflective sheet 160 may be able to uniformly distribute light and effectively reflect light.

[0033] The mold frame 130 may be formed as a substantially rectangular frame and may be disposed to surround all sides of the optical sheets 140. The mold frame 130 may include sidewalls each connected to each other and disposed adjacent to side faces of the optical sheets 140, such that an uppermost surface of the optical sheets 140 is exposed to the liquid crystal panel assembly 120.

The mold frame 130 may be coupled to the lower container 170 and may accommodate the optical sheets 140, the light guide plate 150, the reflective sheet 160 and the light source module 177 therein. The mold frame 130 and the lower container 170 may be coupled to each other in various manners, such as by using hooks or screws.

[0034] The liquid crystal panel 123 may be disposed above the mold frame 130 towards a viewing side of the LCD 100. The upper container 110 may be coupled to the lower container 170 or the mold frame 130 so as to cover (e.g., overlap) upper top edges of the liquid crystal panel 123. The upper container 110 may include an upper face disposed continuous with sidewalls extending towards the rear of the LCD 100, such that an uppermost surface of the liquid crystal panel assembly 120 is exposed to the viewing side of the LCD 100.

[0035] The structure of the liquid crystal panel 123 will hereinafter be described in detail with reference to FIGS. 4A through 4C. FIG. 4A illustrates a plan view of any exemplary embodiment of the liquid crystal panel 123, FIG. 4B illustrates a layout of an exemplary embodiment of a pixel array of the liquid crystal panel 123, and FIG. 4C illustrates an exemplary embodiment of an equivalent circuit diagram of the pixel array shown in FIG. 4B.

[0036] Referring to FIGS. 4A through 4C, the liquid crystal panel 123 may include a plurality of gate lines G_n through G_{n+3} , a plurality of data lines D_m through D_{m+3} , a plurality of pixel electrodes 11, a plurality of storage electrodes 12, a plurality of TFTs 13, the chip film package 126 (e.g., a data driving module) and a gate driving module 127.

[0037] Since the data lines D_m through D_{m+3} extend substantially horizontally in the layout view and in parallel with the long sides of the liquid crystal panel 123, the number of channels of the data driving module 126 can be reduced to two-thirds (2/3), compared with a conventional pixel design method in which data lines extend vertically and in parallel with short sides of a liquid crystal panel. With the number of the number of channels of the data driving module 126 can be reduced to two-thirds (2/3), it is possible to advantageously reduce the manufacturing cost of an LCD. In addition, since the gate driving module 127 is disposed on an insulating substrate (not shown) as an integrated circuit ("IC") during the fab-

rication of a TFT array, a gate driver IC may be unnecessary, and omitted from the structure of the liquid crystal panel 123.

[0038] Referring to FIGS. 4B and 4C, two adjacent data lines may be disposed for each of a plurality of a pixel row 16, and one gate line may be disposed for each of a plurality of a pixel column 17. The gate lines G_n and G_{n+1} may be electrically connected to each other, and the gate lines G_{n+1} and G_{n+2} may be electrically connected to each other. In the layout view, the TFTs 13 may be arranged in a zigzag fashion, and may be physically and electrically connected to the data lines D_m through D_{m+3} and the gate lines G_n through G_{n+3} . In the illustrated embodiment, TFTs 13 disposed in adjacent areas along each of the pixel rows 16, are alternately directly connected to the two adjacent data lines to form the zigzag arrangement.

[0039] Since a gate signal is applied to a pair of horizontally adjacent pixels at the same time, it is possible to secure sufficient pixel charging time. The liquid crystal panel 123 may include a pixel array in which a plurality of pixels are arranged in a matrix, and each of the pixels may extend longer vertically than horizontally in the layout view. The pixel array may include the pixel rows 16 and the pixel columns 17. A number of pixels vertically adjacent to one another may represent the same color. Three pixels respectively representing red, green and blue may be alternately arranged in a longitudinal direction of each of the pixel rows 16.

[0040] The storage electrodes 12 may be substantially disposed near the gate lines G_n through G_{n+3} in order to prevent texture from being generated due to the distortion of an electric field when a gate signal is applied to the gate lines G_n through G_{n+3} .

[0041] In the exemplary embodiment of FIGS. 4A through 4C, two data lines are disposed for each of the pixel rows 16, and one gate line is disposed for each of the pixel columns 17. However, the present invention is not restricted thereto. Alternatively, one data line may be disposed for each of the pixel rows 16, and one gate line may be disposed for each of the pixel columns 17. With one data line being disposed for each of the pixel rows 16, and one gate line being disposed for each of the pixel columns 17, the number of data lines, e.g., the number of channels of the data driving module 126, may be reduced to one-half (1/2), compared with the illustrated exemplary embodiment of FIGS. 4A through 4C. Advantageously, it is possible to reduce the manufacturing cost of an LCD and improve the aperture ratio of an LCD.

[0042] FIGS. 5A through 5C illustrate alternative exemplary embodiments of the LCD 100 shown in FIG. 1, e.g., LCDs 101 through 103.

[0043] Referring to the LCD 101 shown in FIG. 5A, a chip film package 126 may be disposed on the right transverse side of a liquid crystal panel 123, instead of on the left transverse side as illustrated in FIGS. 1-3.

[0044] Referring to the LCD 102 shown in FIG. 5B, a chip-on-glass ("COG") chip 126b may be mounted on a

liquid crystal panel 123 as a data driving module, and the COG chip 126b and a PCB 128 may be electrically connected to each other by a circuit film 126a, which is disposed on the left transverse side of the liquid crystal panel 123. The circuit film 126a may electrically and physically connect the COG chip 126b and the PCB 128.

[0045] Referring to the LCD 103 shown in FIG. 5C, a PCB 128, a circuit film 126a and a COG chip 126b may all be disposed on the right transverse side of a liquid crystal panel 123, instead of on the left transverse side as illustrated in FIG. 5B. The circuit film 126a may electrically and physically connect the COG chip 126b and the PCB 128.

[0046] An LCD according to another exemplary embodiment of the present invention will hereinafter be described in detail with reference to FIG. 6. FIG. 6 illustrates a bottom view of an LCD 104 according to a second exemplary embodiment of the present invention. In FIGS. 1 through 4C and 6, like reference numerals indicate like elements, and thus, detailed descriptions thereof will be omitted.

[0047] Referring to the layout view of FIG. 6, a plurality of light source units 178 may be disposed above a light guide plate (not shown) and may be arranged along the upper side of the LCD 104 which is a longitudinal side of the LCD 100. In order to prevent signal infiltration between a circuit board 176 and a film module 186, a second connector 184 may be disposed closer to the light source units 178 than a first connector 182 to the light source units 178. In the layout view, the second connector 184 may be located higher than the first connector 182 in the longitudinal direction of a PCB 128.

[0048] In the illustrated embodiment, the first connector 182 and the second connector 184 may each be disposed at an end of the PCB 128, in contrast to FIG. 2 where the first connector 182 is disposed at a substantially central portion of the PCB 128. Where the first connector 182 and the second connector 184 are each disposed at an end of the PCB 128, the circuit board 176 of the light source module 177 and the film module 186 are extended to opposing longitudinal sides of the LCD 104, where in FIG. 2, both the circuit board 176 and the film module 186 are extended to a same longitudinal side of the LCD 100.

[0049] An LCD according to another exemplary embodiment of the present invention will hereinafter be described in detail with reference to FIGS. 7A and 7B. FIG. 7A illustrates a front view and a side views of an LCD 105 according to a third exemplary embodiment of the present invention, and FIG. 7B illustrates a rear view of the LCD 105. In FIGS. 1 through 4C, 7A, and 7B, like reference numerals indicate like elements, and thus, detailed descriptions thereof will be omitted.

[0050] Referring to FIGS. 7A and 7B, a chip film package 126 may be electrically and physically connected to a plurality of data lines (not shown), which are disposed on a liquid crystal panel 123, and extend substantially horizontally in the layout view, and a PCB 128 may be

physically and electrically connected to the chip film package 126. The film package 126 and the PCB 128 may be disposed near one of the short transverse sides of the liquid crystal panel 123. A plurality of light source units 178 may be disposed between the PCB 128 and the liquid crystal panel 123 in the layout view. More specifically, the light source units 178 may be disposed on the left side of a light guide plate 150, and particularly, on the left transverse side of the LCD 105. In contrast, the plurality of light sources 178 are disposed substantially parallel to longitudinal sides of the LCD 100 in FIGS. 1-3.

[0051] If a circuit board 176 and a film module 186 overlap each other, signal interference may occur. In order to prevent signal interference between the circuit board 176 and the film module 186, the circuit board 176 and the film module 186 may be arranged so as not to overlap each other. In the illustrated embodiment, an end of the circuit board 176 and an end of the film module 186 opposing the second connector 184 and the first connector 182 respectively, are both disposed extended toward a same longitudinal side of the LCD 105.

[0052] An LCD according to another exemplary embodiment of the present invention will hereinafter be described in detail with reference to FIGS. 8A and 8B. FIG. 8A illustrates a front view and side views of an LCD 106 according to a fourth exemplary embodiment of the present invention, and FIG. 8B illustrates a rear view of the LCD 106. In FIGS. 1 through 4C, 8A, and 8B, like reference numerals indicate like elements, and thus, detailed descriptions thereof will be omitted.

[0053] Referring to FIGS. 8A and 8B, a chip film package 126 may be physically and electrically connected to a plurality of data lines (not shown), which are disposed on a liquid crystal panel 123 and extend substantially horizontally in the layout view, and a PCB 128 may be physically and electrically connected to the chip film package 126. The chip film package 126 and the PCB 128 may be disposed near one of the short transverse sides of the liquid crystal panel 123.

[0054] A plurality of light source units 178 may be arranged along whichever of the short transverse sides of the liquid crystal panel is more distant than the other from the PCB 128. In the illustrated embodiment, the light source units 178 may be disposed on the right side of a light guide plate 150 in the layout view, and particularly, on the right side of the LCD 106.

[0055] If a circuit board 176 and a film module 186 overlap each other, signal interference may occur. In order to prevent signal interference between the circuit board 176 and the film module 186, the circuit board 176 and the film module 186 may be arranged so as not to overlap each other. The circuit board 176 may connect the PCB 128 and the light source units 178 by extending horizontally along the surface of the bottom of the LCD 106. A first end of the circuit board 176 and a first end of the film module 186 are connected to the second connector 184 and the first connector 182, respectively. A second end

of each of the circuit board 176 and the film module 186 are respectively disposed extended to adjacent sides of the LCD 106, such as a longitudinal side and a transverse side adjacent to the longitudinal side.

[0056] An LCD according to an example not according to the present invention will hereinafter be described in detail with reference to FIGS. 9A and 9B. FIG. 9A illustrates a front view and side views of an LCD 107 not according to the present invention, and FIG. 9B illustrates a rear view of the LCD 107. In FIGS. 1 through 4C, 9A, and 9B, like reference numerals indicate like elements, and thus, detailed descriptions thereof will be omitted.

[0057] Referring to FIGS. 9A and 9B, a plurality of light source units 178 may be disposed below a light guide plate 150 in the layout view, and may be arranged along the lower longitudinal side of the LCD 107. A chip film package 126 may be physically and electrically connected to a plurality of data lines (not shown), which are disposed on a liquid crystal panel 123. The chip film package 126 may be disposed near one of the short transverse sides of the liquid crystal panel 123. Since a PCB 128 is connected to the liquid crystal panel 123 by the chip film package 126, which includes a flexible film, the PCB 128 may be bent along the short transverse side of the liquid crystal panel 123 and may be disposed at a rear of the liquid crystal panel 123.

[0058] If a circuit board 176 and a film module 186 overlap each other, signal interference may occur. In order to prevent signal interference between the circuit board 176 and the film module 186, the circuit board 176 and the film module 186 may be arranged so as not to overlap each other.

[0059] An LCD not according to the present invention will hereinafter be described in detail with reference to FIGS. 10A and 10B. FIG. 10A illustrates a front view and side views of an LCD 108 not according to the present invention, and FIG. 10B illustrates a rear view of the LCD 108. In FIGS. 1 through 4C, 10A, and 10B, like reference numerals indicate like elements, and thus, detailed descriptions thereof will be omitted.

[0060] Referring to FIGS. 10A and 10B, a chip film package 126 may be physically and electrically connected to a plurality of data lines (not shown), which are disposed on a liquid crystal panel 123 and extend substantially horizontally in a longitudinal direction of the liquid crystal panel 123, and a PCB 128 may be physically and electrically connected to the chip film package 126. The chip film package 126 and the PCB 128 may be disposed near one of the short transverse sides of the liquid crystal panel 123. A plurality of light source units 178 may be arranged along whichever of the short transverse sides of the liquid crystal panel is more distant than the other from the PCB 128. In the illustrated example not according to the invention, the light source units 178 may be disposed on the right side of a light guide plate 150 in the layout view, and particularly, on the right side of the LCD 108. Since the PCB 128 is connected to the liquid crystal panel 123 by the chip film package, which includes a flexible film,

the PCB 128 may be bent along the transverse side of the liquid crystal panel 123 and may be disposed at a rear of the liquid crystal panel 123.

[0061] In order to prevent an increase in the overall thickness of the LCD 108, the light guide plate 250 may have a wedge-shaped structure tapering from the light source units 178 to the PCB 128.

[0062] If a circuit board 176 and a film module 186 overlap each other, signal interference may occur. In order to prevent signal interference between the circuit board 176 and the film module 186, the circuit board 176 and the film module 186 may be arranged so as not to overlap each other. The circuit board 176 may connect the PCB 128 and the light source units 178 by extending substantially horizontally along the surface of the bottom of the LCD 108.

[0063] While the present invention has been particularly shown and described with reference to exemplary embodiments thereof, it will be understood by those of ordinary skill in the art that various changes in form and details may be made therein without departing from the scope of the present invention as defined by the following claims.

Claims

1. A liquid crystal display (100; 101; 102, 103; 104; 105; 106; 107; 108) comprising:

a liquid crystal panel (123) having a rectangular shape;

a plurality of gate lines (Gn to Gn+3) disposed on the liquid crystal panel (123) and extending substantially in parallel with the short sides of the liquid crystal panel (123);

a plurality of data lines (Dm to Dm+3) insulated from the gate lines (Gn to Gn+3), intersecting the gate lines (Gn to Gn+3) and extending substantially in parallel with the long sides of the liquid crystal panel (123); a printed circuit board (128) for providing an image signal to the liquid crystal panel (123); a film module (186) which is connected to an external controller; **characterized in that**

the printed circuit board (128) is disposed on a level with the liquid crystal panel (123) such that a surface of the printed circuit board (128) is disposed substantially coplanar with a surface of the liquid crystal panel (123) and at a short side of the liquid crystal panel (123)

and **in that** the liquid crystal display further comprises a light guide plate (150; 250) overlapping the liquid crystal panel (123);

a light source module (177) generating and providing light to the light guide plate (150; 250); and a circuit board (176) comprising a first portion on which the light source module (177) is mount-

ed,

and a second portion, wherein the printed circuit board (128) includes a first connector (182) disposed on the printed circuit board (128) and comprising a connection terminal arranged to face an edge of the liquid crystal panel (123) and connected to the film module (186), and a second connector (184) disposed on the printed circuit board (128) and comprising a connection terminal arranged to face said edge of the liquid crystal panel (123) and connected to the circuit board (176), wherein the film module (186) and the second portion of the circuit board (176) do not overlap each other at the light guide side of the liquid crystal display (100).

2. The liquid crystal display (100; 101; 102, 103; 104; 105; 106; 107; 108) of claim 1, further comprising:

a gate driving module (127) connected to the gate lines (Gn to Gn+3), disposed on the liquid crystal panel (123) as an integrated circuit and disposed at a long side of the liquid crystal panel (123); and

a data driving module (126) connected to the data lines (Dm to Dm+3) and disposed at a short side of the liquid crystal panel (123).

3. The liquid crystal display (102, 103) of claim 1, further comprising:

a chip-on-glass chip (126b) mounted on the liquid crystal panel (123); and

a circuit film (126a) connecting the chip-on-glass chip (126b) and the printed circuit board (128).

4. The liquid crystal display (100; 101; 102, 103; 104) of claim 1,

wherein the light source module (177) is disposed adjacent to one side of the light guide plate (150), and arranged substantially parallel to the long sides of the of the liquid crystal panel (123).

5. The liquid crystal display (100; 105) of claim 1, wherein the light source module (177) is disposed between the printed circuit board (128) and the liquid crystal panel (123), and arranged substantially parallel to the short sides of the liquid crystal panel (123).

6. The liquid crystal display (105; 106; 108) of claim 1, wherein the light source module (177) is arranged near one of the short sides of the liquid crystal panel (123) which is more distant from the printed circuit board (128) than the remaining short side.

7. The liquid crystal display of claim 1, further comprising a pixel including a long side and a short side and

disposed to the liquid crystal panel (123), wherein the plurality of gate lines extends substantially in parallel with the long side of the pixel, and wherein the plurality of data lines extends substantially in parallel with the short side of the pixel.

5

Patentansprüche

1. Flüssigkristallanzeige (100; 101; 102, 103; 104; 105; 106; 107; 108), umfassend:

ein Flüssigkristall-Anzeigefeld (123) mit rechteckiger Form;

eine Mehrzahl von Gate-Leitungen (G_n bis G_{n+3}), die auf dem Flüssigkristall-Anzeigefeld (123) angeordnet sind und sich im Wesentlichen parallel zu den kurzen Seiten des Flüssigkristall-Anzeigefelds (123) erstrecken;

eine Mehrzahl von Datenleitungen (D_m bis D_{m+3}), die von den Gate-Leitungen (G_n bis G_{n+3}) isoliert sind, die Gate-Leitungen (G_n bis G_{n+3}) kreuzen und sich im Wesentlichen parallel zu den langen Seiten des Flüssigkristall-Anzeigefelds (123) erstrecken;

eine Leiterplatine (128) zur Bereitstellung eines Bildsignals an das Flüssigkristall-Anzeigefeld (123);

ein Filmmodul (186), das an eine externe Steuerung angeschlossen ist;

dadurch gekennzeichnet, dass

die Leiterplatine (128) derart auf einer Ebene mit dem Flüssigkristall-Anzeigefeld (123) angeordnet ist, dass eine Oberfläche der Leiterplatine (128) im wesentlichen koplanar mit einer Oberfläche des Flüssigkristall-Anzeigefelds (123) und an einer kurzen Seite des Flüssigkristall-Anzeigefelds (123) angeordnet ist,

und dass die Flüssigkristallanzeige ferner eine Lichtleiterplatte (150; 250) umfasst, die das Flüssigkristall-Anzeigefeld (123) überlappt;

ein Lichtquellenmodul (177), das Licht generiert und die Lichtleiterplatte (150; 250) damit versorgt; und

eine Leiterplatte (176), die einen ersten Abschnitt umfasst, auf dem das Lichtquellenmodul (177) montiert ist, und einen zweiten Abschnitt umfasst, wobei die Leiterplatine (128) einen ersten Verbinder (182) umfasst, der auf der Leiterplatine (128) angeordnet ist, und einen Verbindungsanschluss umfasst, der so angeordnet ist, dass er einer Kante des Flüssigkristall-Anzeigefelds (123) zugewandt und an das Filmmodul (186) angeschlossen ist; und

dass ein zweiter Verbinder (184) auf der Leiterplatine (128) angeordnet ist und einen Verbindungsanschluss umfasst, der so angeordnet ist,

10

2. Flüssigkristallanzeige (100; 101; 102, 103; 104; 105; 106; 107; 108) gemäß Anspruch 1, ferner umfassend:

ein Gate-Treibermodul (127), das mit den Gate-Leitungen (G_n bis G_{n+3}) verbunden ist und auf dem Flüssigkristall-Anzeigefeld (123) als integrierter Schaltkreis angeordnet und an einer langen Seite des Flüssigkristall-Anzeigefelds (123) angeordnet ist; und

ein Datentreibermodul (126), das mit den Datenleitungen (D_m bis D_{m+3}) verbunden und an einer kurzen Seite des Flüssigkristall-Anzeigefelds (123) angeordnet ist.

25

3. Flüssigkristallanzeige (102, 103) gemäß Anspruch 1, ferner umfassend:

einen auf dem Flüssigkristall-Anzeigefeld (123) montierten Chip-auf-Glas-Chip (126b); und einen Dünnschichtschaltkreis (126a), der den Chip-auf-Glas-Chip (126b) und die Leiterplatine (128) verbindet.

30

4. Flüssigkristallanzeige (100; 101; 102, 103; 104) gemäß Anspruch 1, wobei das Lichtquellenmodul (177) angrenzend an eine Seite der Lichtleiterplatte (150) und im Wesentlichen parallel zu den langen Seiten des Flüssigkristall-Anzeigefelds (123) angeordnet ist.

35

5. Flüssigkristallanzeige (100; 105) gemäß Anspruch 1, wobei das Lichtquellenmodul (177) zwischen der Leiterplatine (128) und dem Flüssigkristall-Anzeigefeld (123) und im Wesentlichen parallel zu den kurzen Seiten des Flüssigkristall-Anzeigefelds (123) angeordnet ist.

40

45

6. Flüssigkristallanzeige (105; 106; 108) gemäß Anspruch 1, wobei das Lichtquellenmodul (177) nahe einer der kurzen Seiten des Flüssigkristall-Anzeigefelds (123) angeordnet ist, das sich weiter entfernt von der Leiterplatine (128) befindet als die restliche kurze Seite.

50

7. Flüssigkristallanzeige gemäß Anspruch 1, ferner umfassend ein Pixel, das eine lange Seite und eine kurze Seite umfasst und am Flüssigkristall-Anzeigefeld (123) angeordnet ist, wobei sich die Mehrzahl von Gate-Leitungen im We-

55

sentlichen parallel zu der langen Seite des Pixels erstreckt und wobei sich die Mehrzahl der Datenleitungen im Wesentlichen parallel zu der kurzen Seite des Pixels erstreckt.

Revendications

1. Un écran à cristaux liquides (100 ; 101 ; 102, 103 ; 104 ; 105 ; 106 ; 107 ; 108) comprenant :

un panneau à cristaux liquides (123) ayant une forme rectangulaire ;

une pluralité de lignes de porte (Gn à Gn+3) disposées sur le panneau à cristaux liquides (123) et s'étendant substantiellement en parallèle avec les côtés courts du panneau à cristaux liquides (123) ;

une pluralité de lignes de données (Dm à Dm+3) isolées des lignes de porte (Gn à Gn+3), croisant les lignes de porte (Gn à Gn+3) et s'étendant substantiellement en parallèle avec les côtés longs du panneau à cristaux liquides (123) ;

une carte de circuit imprimé (128) pour fournir un signal d'image au panneau à cristaux liquides (123) ; un module à film (186) qui est connecté à un contrôleur externe ; **caractérisé en ce que** la carte de circuit imprimé (128) est disposée sur un niveau avec le panneau à cristaux liquides (123) de sorte qu'une surface de la carte de circuit imprimé (128) soit disposée substantiellement de façon coplanaire avec une surface du panneau à cristaux liquides (123) et sur un côté court du panneau à cristaux liquides (123)

et **en ce que** l'écran à cristaux liquides comprend également une plaque guide-lumière (150 ; 250) chevauchant le panneau à cristaux liquides (123) ;

un module source de lumière (177) générant et fournissant de la lumière à la plaque guide-lumière (150 ; 250) ; et

une carte de circuit (176) comprenant une première partie sur laquelle le module de source de lumière (177) est monté, et une deuxième partie où la carte de circuit imprimé (128) inclut un premier connecteur (182) disposé sur la carte de circuit imprimé (128) et comprenant un terminal de connexion disposé pour faire face à un bord du panneau à cristaux liquides (123) et connecté au module à film (186) ; et

un deuxième connecteur (184) disposé sur la carte de circuit imprimé (128) et comprenant un terminal de connexion disposé pour faire face à ce bord du panneau à cristaux liquides (123) et connecté à la carte de circuit (176) ;

où le module à film (186) et la deuxième partie de la carte de circuit (176) ne se chevauchent

pas sur le côté du guide-lumière de l'écran à cristaux liquides (100).

2. L'écran à cristaux liquides (100 ; 101 ; 102, 103 ; 104 ; 105 ; 106 ; 107 ; 108) de la revendication 1, comprenant de plus :

un module d'entraînement de porte (127) connecté aux lignes de porte (Gn à Gn+3), disposé sur le panneau à cristaux liquides (123) comme un circuit intégré et disposé sur un côté long du panneau à cristaux liquides (123) ; et un module d'entraînement de données (126) connecté aux lignes de données (Dm à Dm+3) et disposé sur un côté court du panneau à cristaux liquides (123).

3. L'écran à cristaux liquides (102, 103) de la revendication 1, comprenant de plus :

une puce *chip-on-glass* (126b) montée sur le panneau à cristaux liquides (123) ; et un film pour circuits (126a) connectant la puce *chip-on-glass* (126b) et la carte de circuit imprimé (128).

4. L'écran à cristaux liquides (100 ; 101 ; 102, 103 ; 104) de la revendication 1, où le module de source de lumière (177) est disposé de façon adjacente à un côté de la plaque guide-lumière (150), et disposé substantiellement parallèle aux côtés longs du panneau à cristaux liquides (123).

5. L'écran à cristaux liquides (100 ; 105) de la revendication 1, où le module de source de lumière (177) est disposé entre la carte de circuit imprimé (128) et le panneau à cristaux liquides (123) et disposé substantiellement parallèle aux côtés courts du panneau à cristaux liquides (123).

6. L'écran à cristaux liquides (105 ; 106 ; 108) de la revendication 1, où le module de source de lumière (177) est disposé à proximité d'un des côtés courts du panneau à cristaux liquides (123) qui est plus distant de la carte de circuit imprimé (128) que le côté court restant.

7. L'écran à cristaux liquides de la revendication 1, comprenant de plus un pixel incluant un côté long et un côté court et disposé sur le panneau à cristaux liquides (123), où la pluralité de lignes de porte s'étend substantiellement en parallèle avec le côté long du pixel, et où la pluralité de lignes de données s'étend substantiellement en parallèle avec le côté court du pixel.

Fig. 1

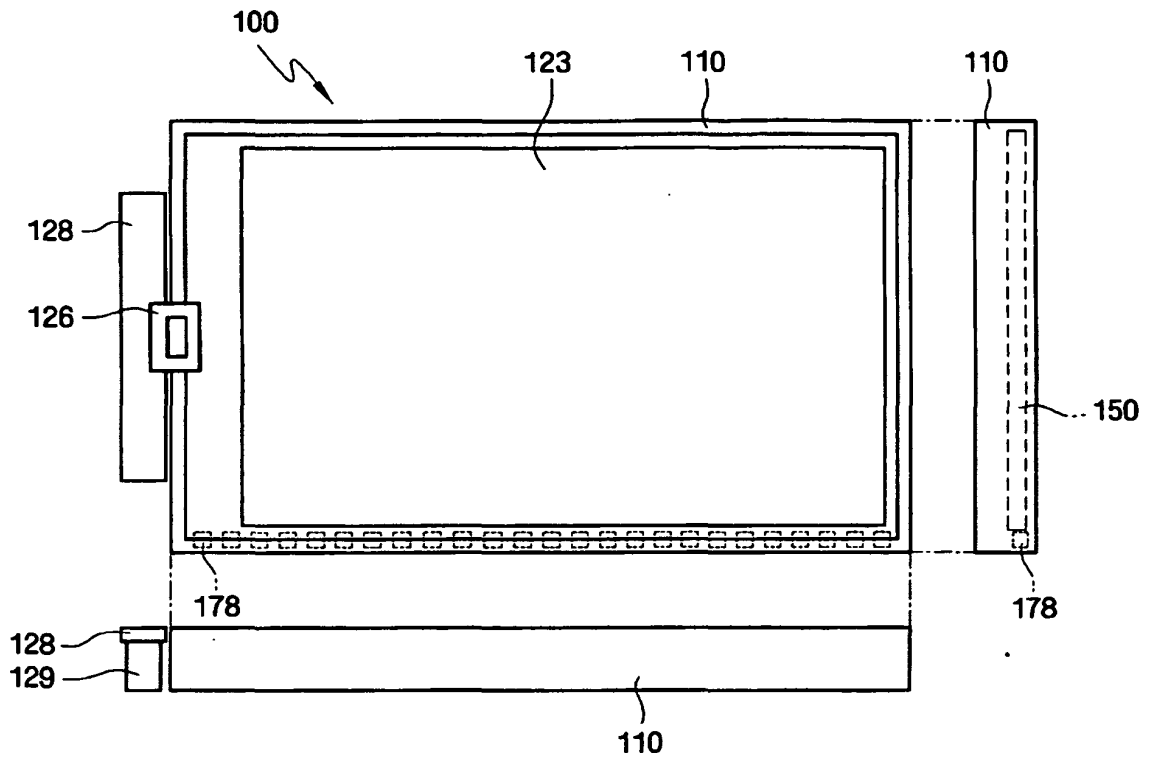

Fig. 2

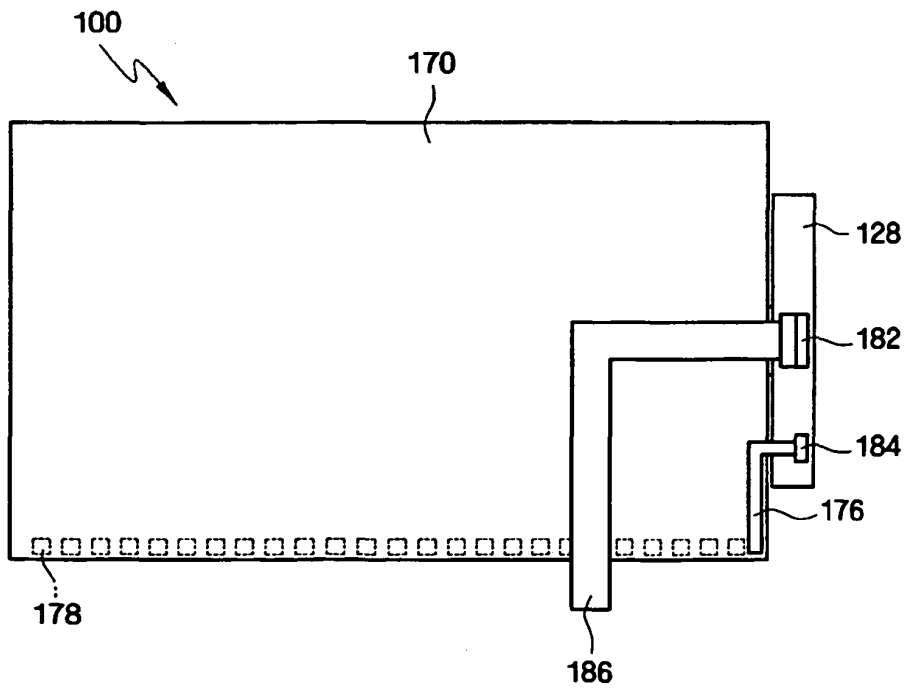

Fig. 3

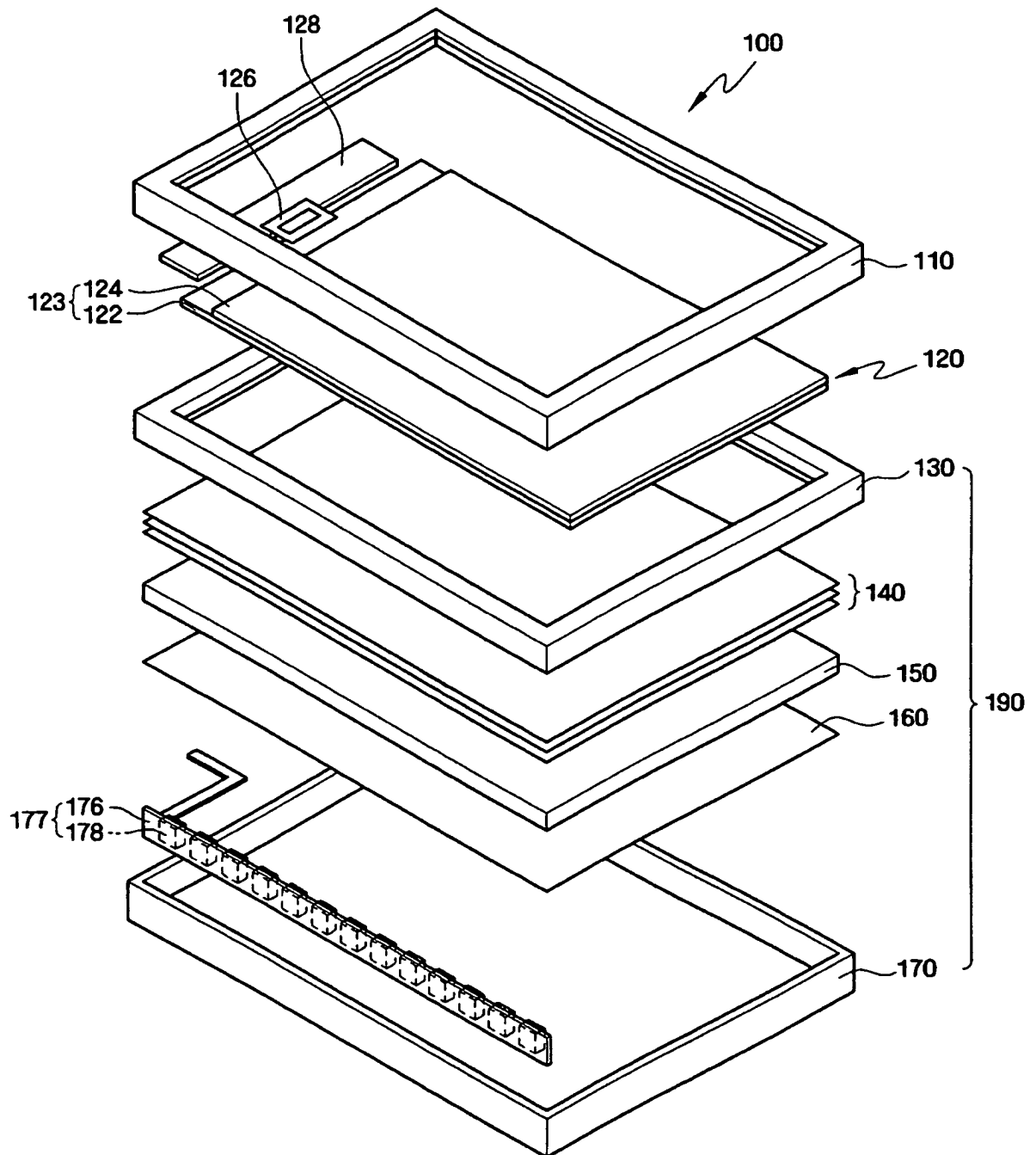

Fig. 4A

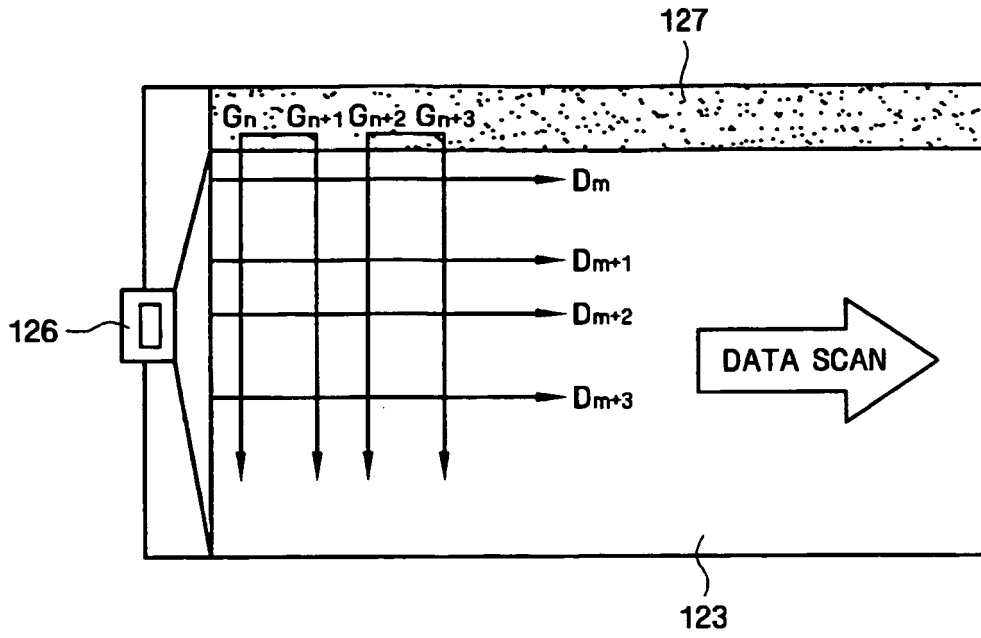

Fig. 4B

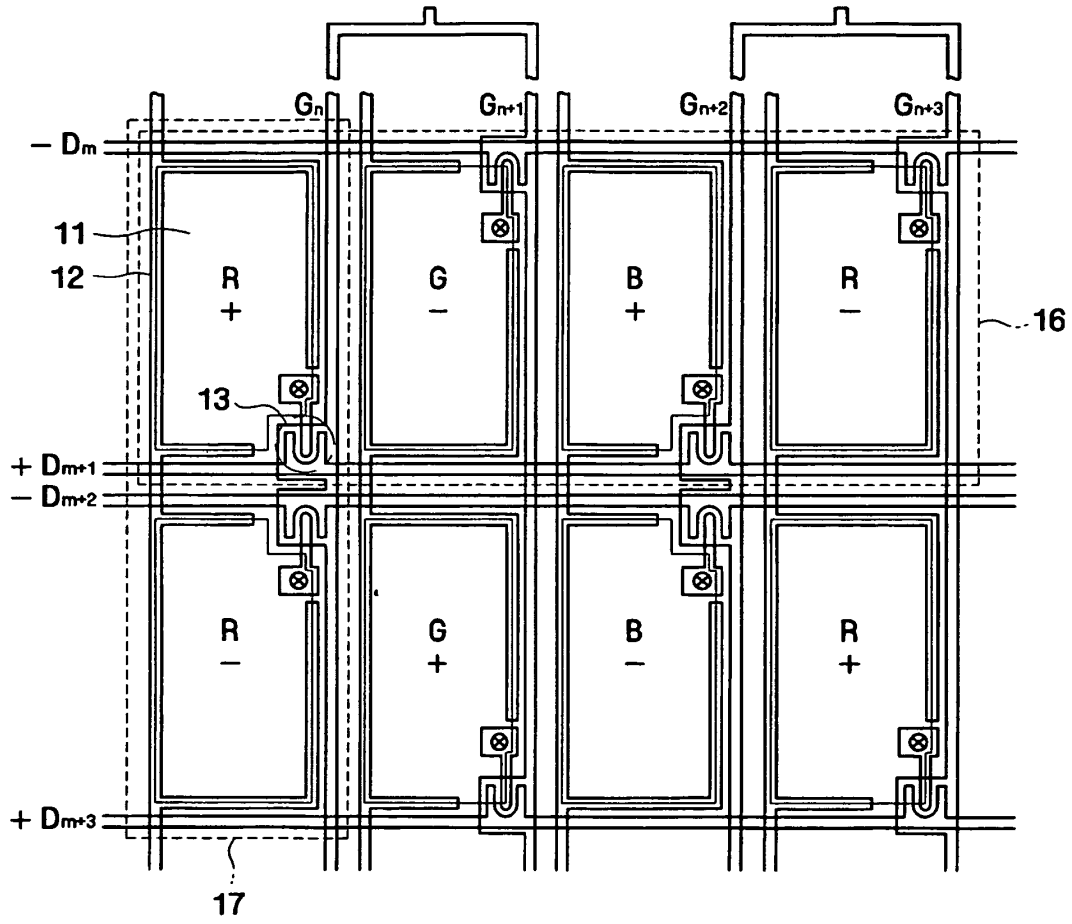

Fig. 4C

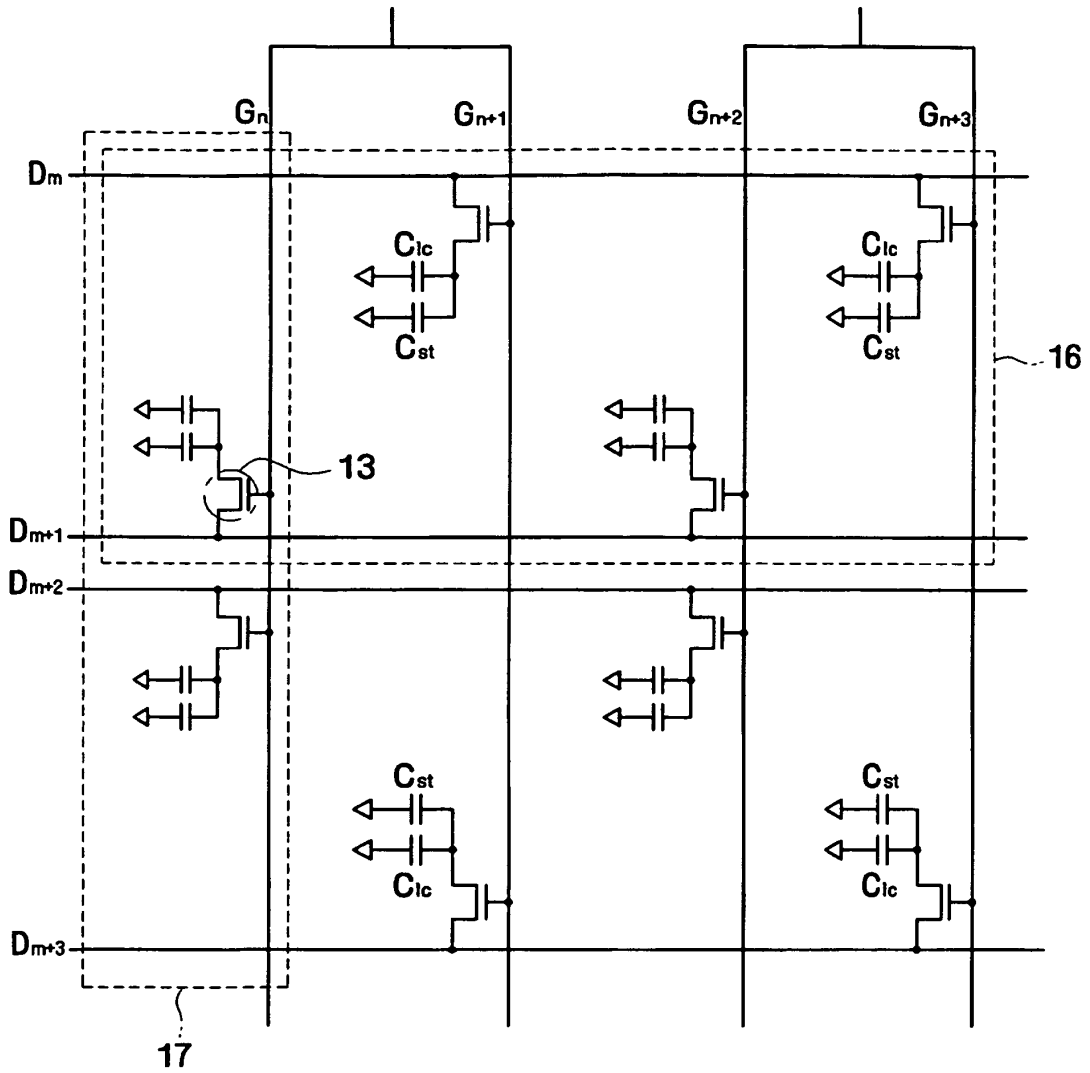

Fig. 5A

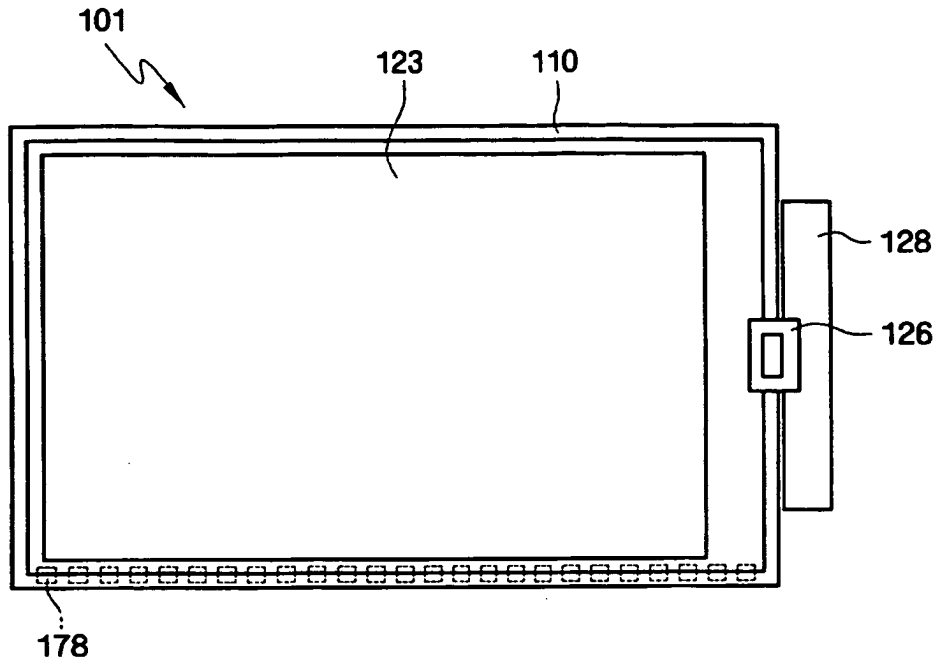

Fig. 5B

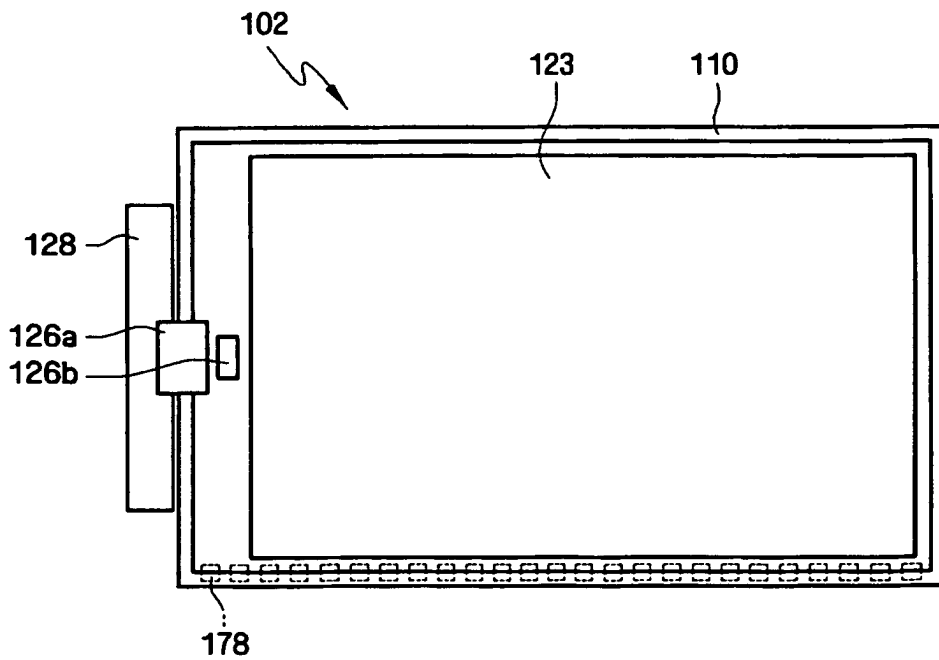

Fig. 5C

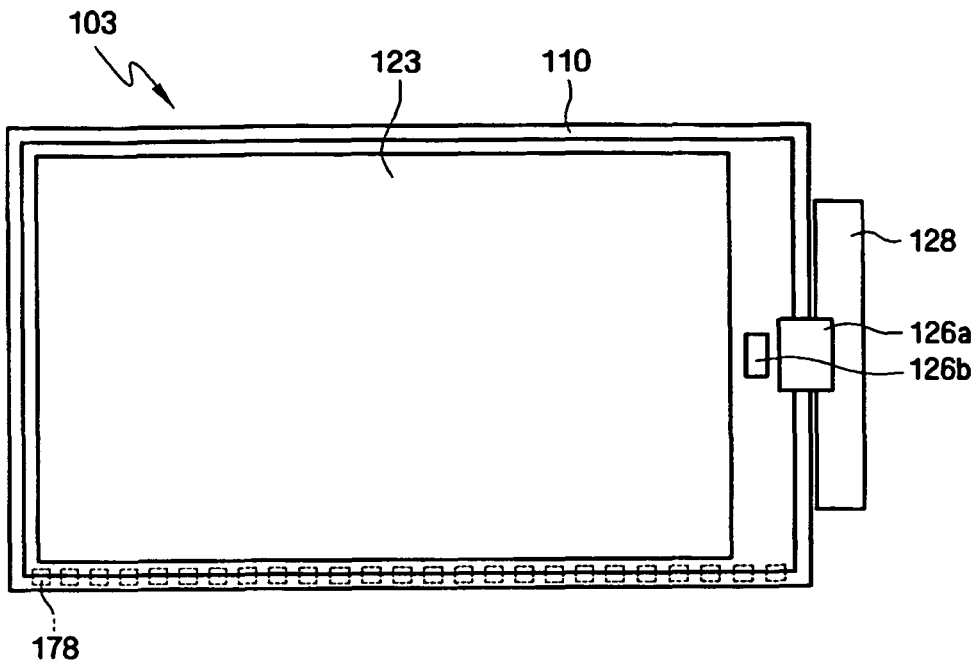

Fig. 6

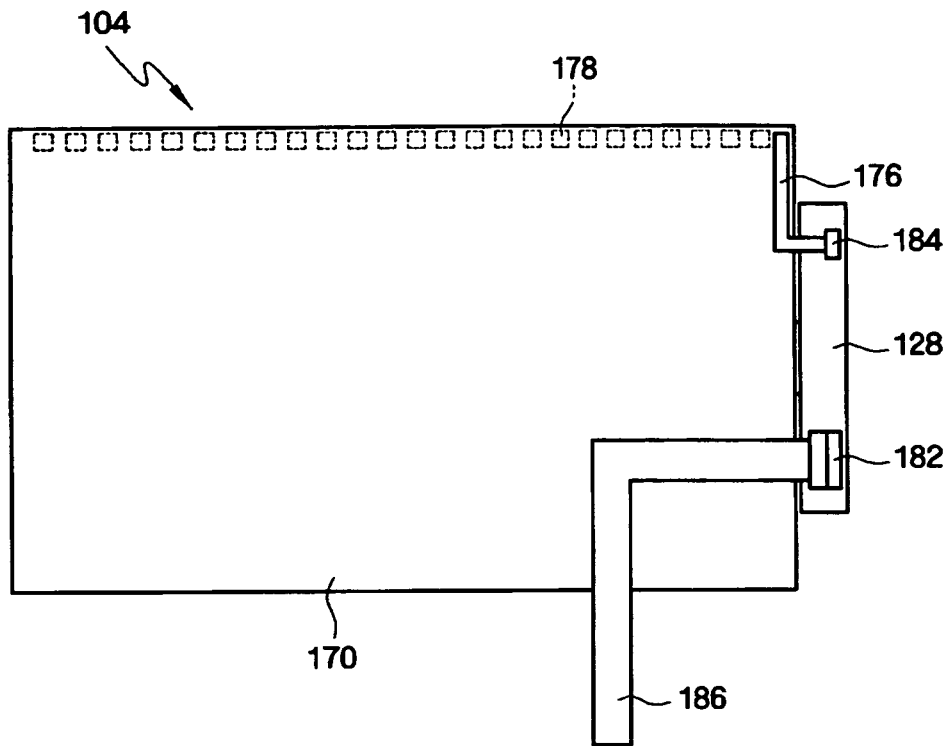

Fig. 7A

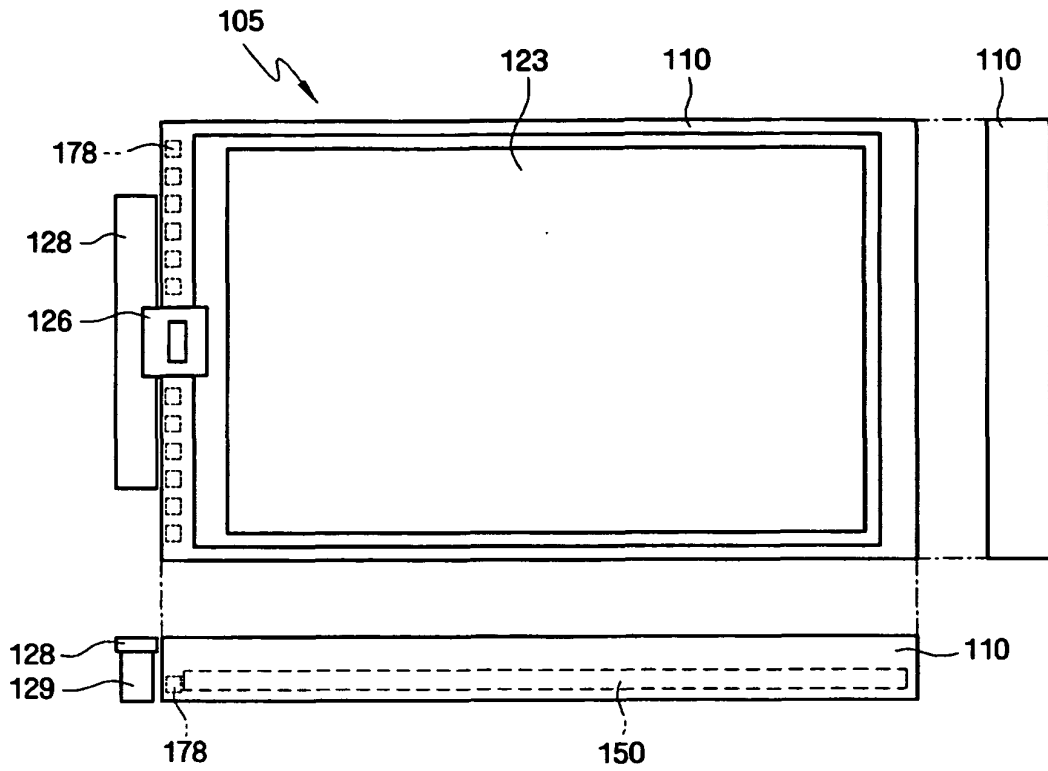

Fig. 7B

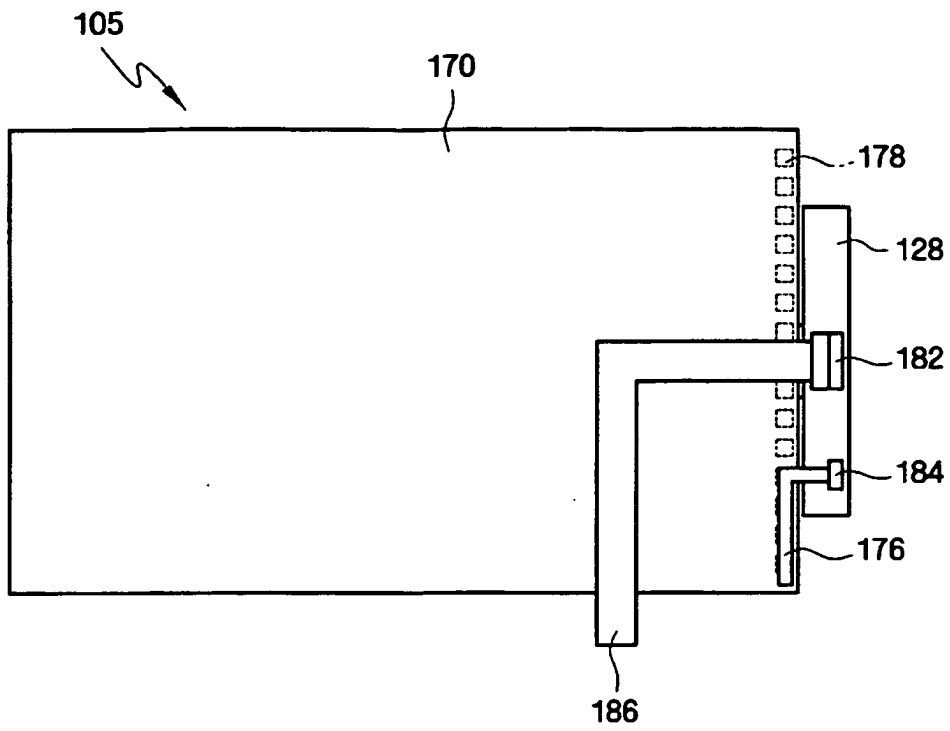

Fig. 8A

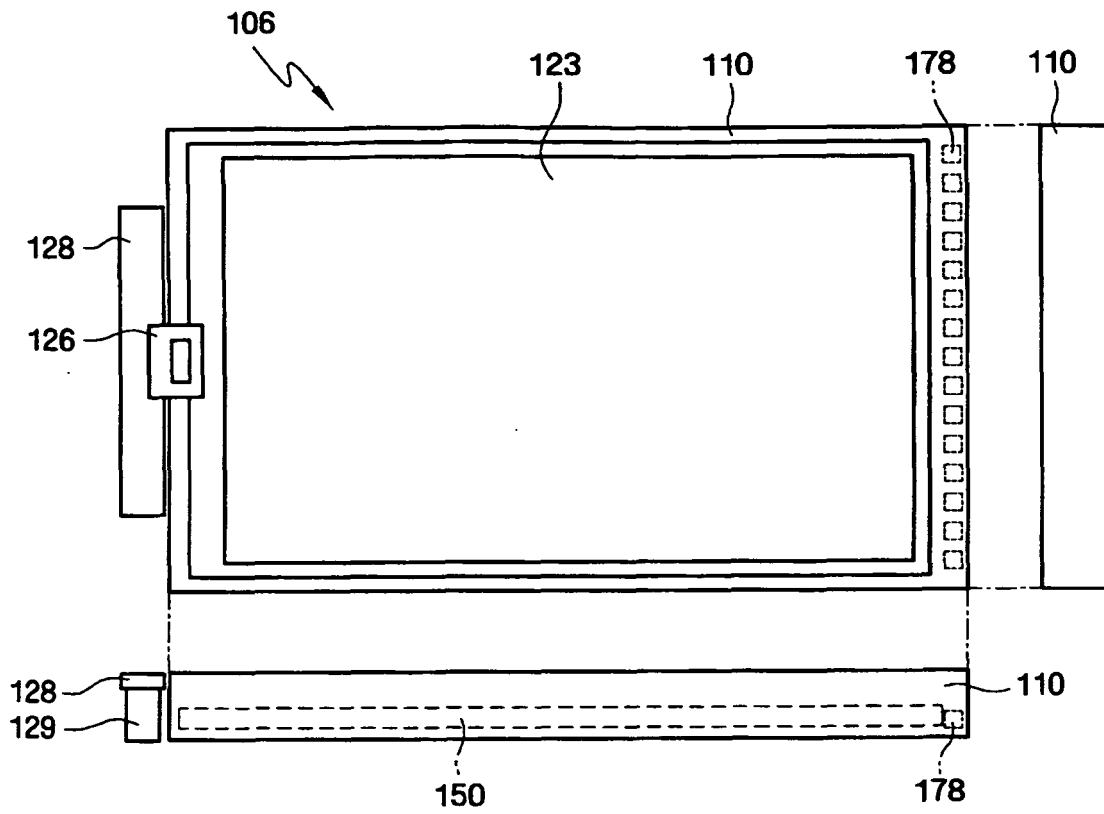

Fig. 8B

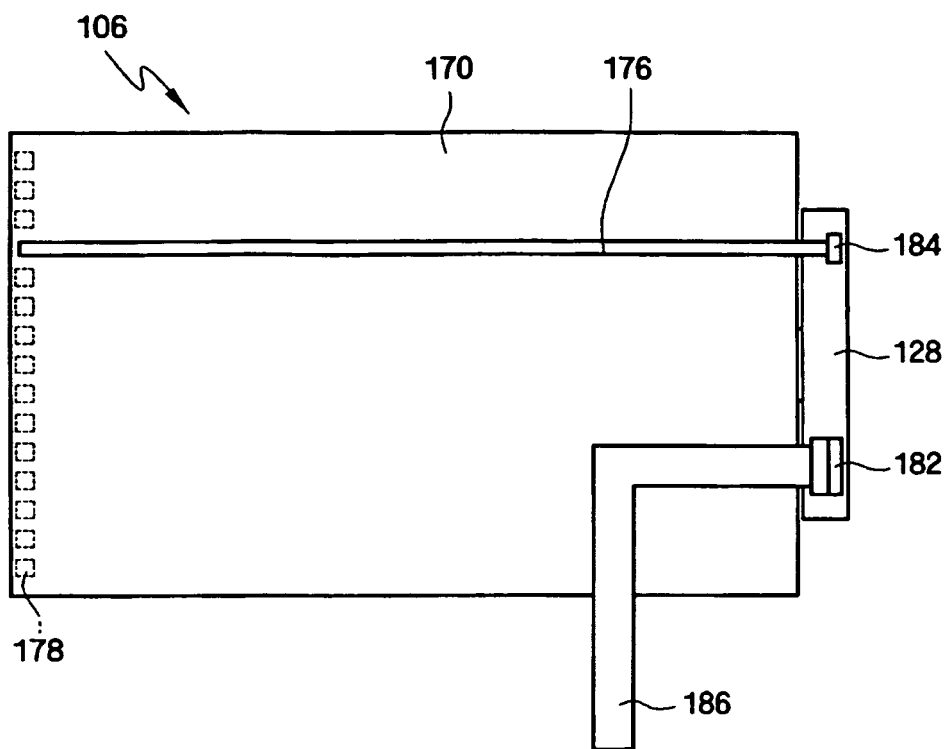

Fig. 9A

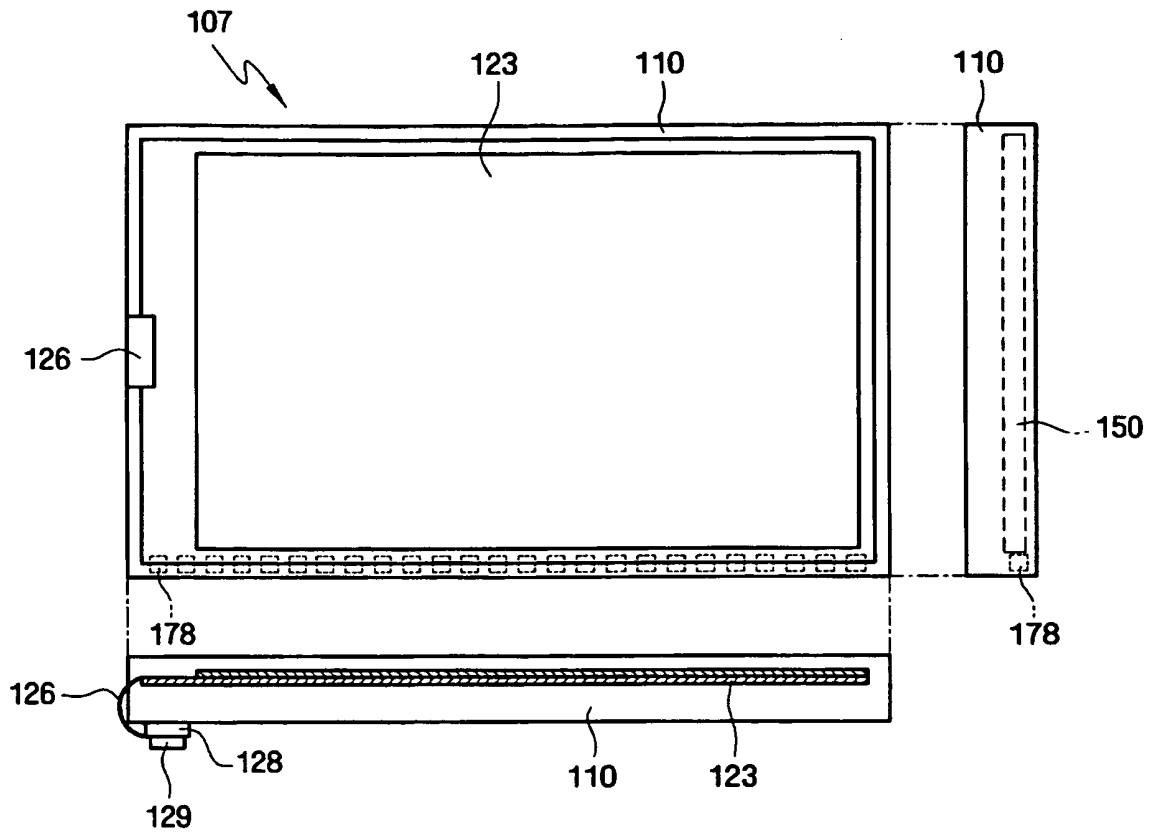

Fig. 9B

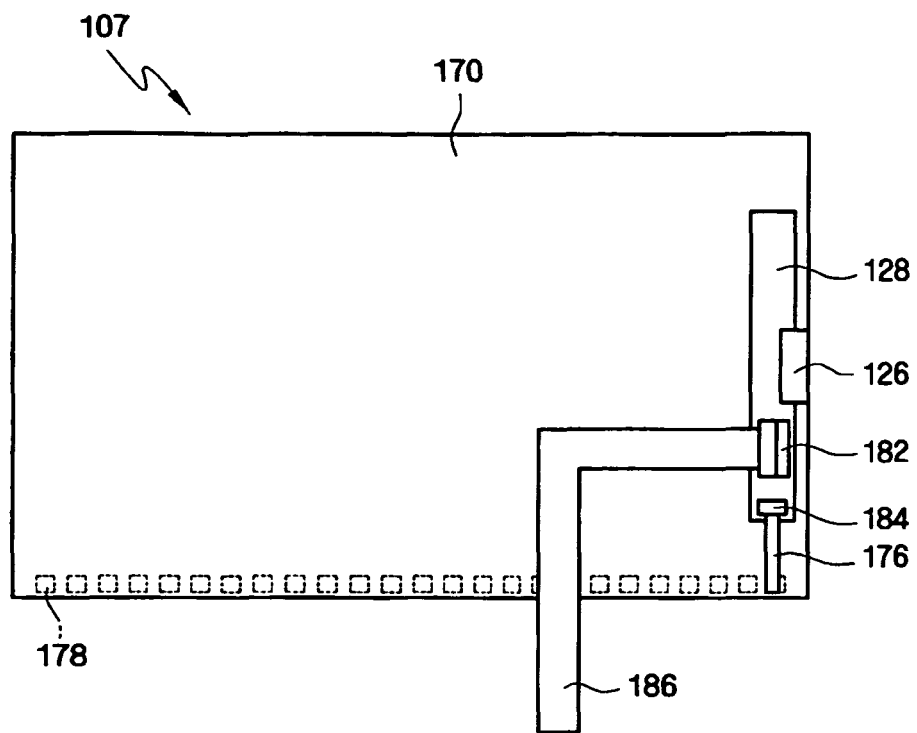

Fig. 10A

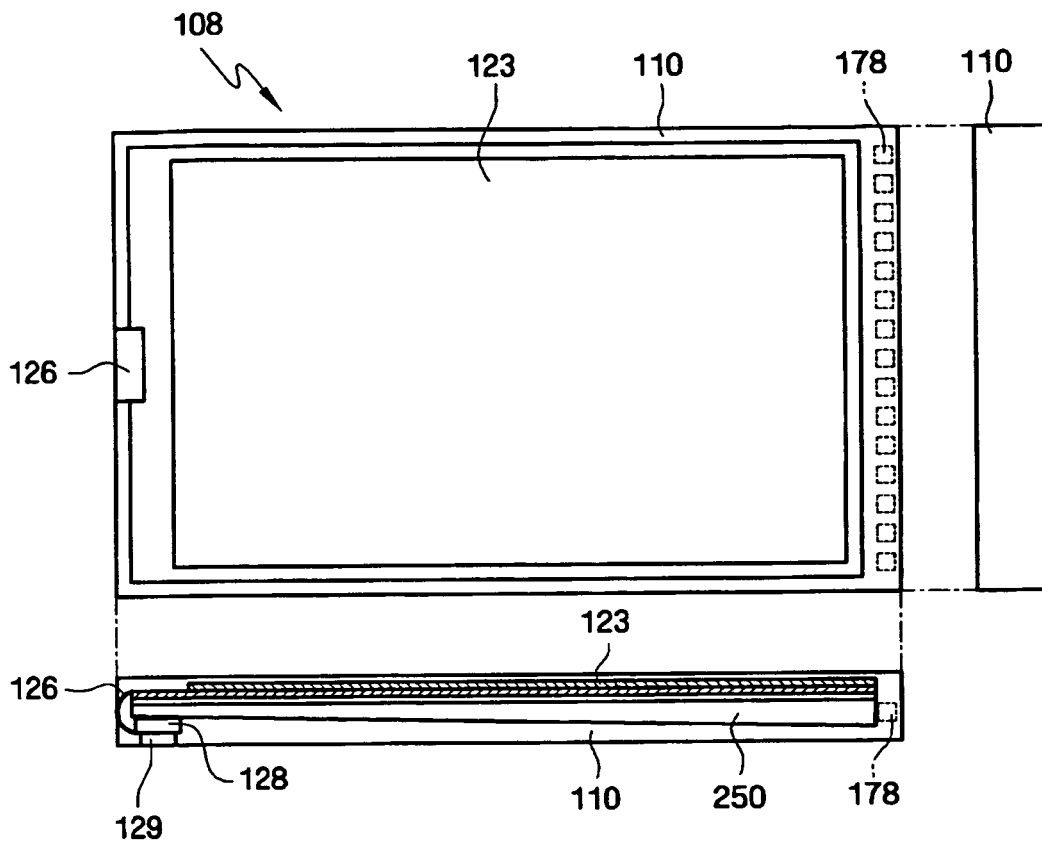
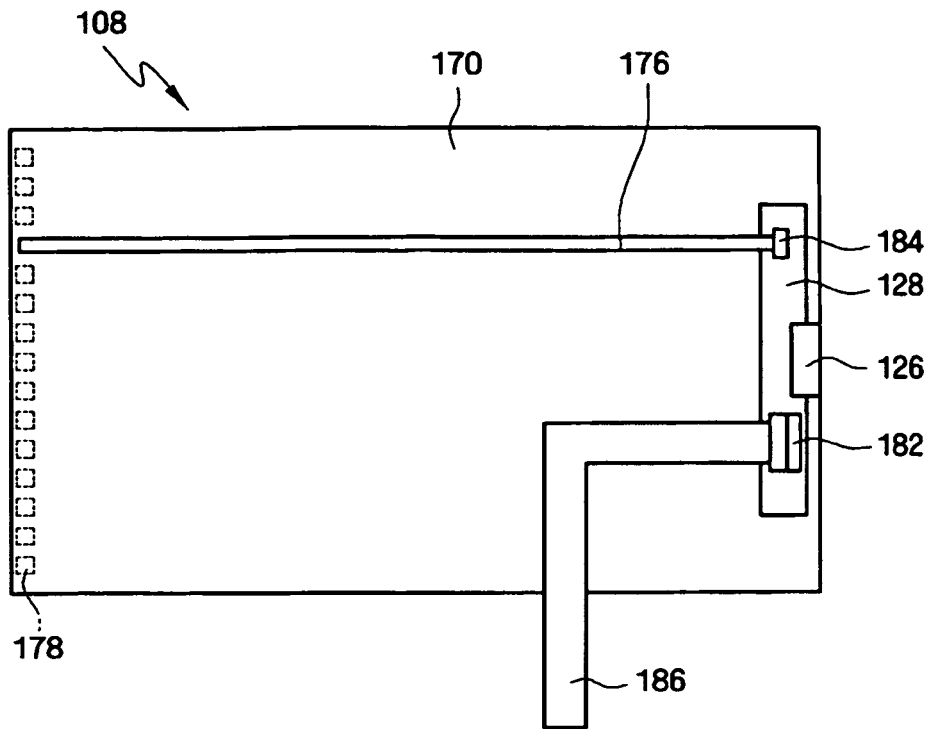

Fig. 10B



REFERENCES CITED IN THE DESCRIPTION

This list of references cited by the applicant is for the reader's convenience only. It does not form part of the European patent document. Even though great care has been taken in compiling the references, errors or omissions cannot be excluded and the EPO disclaims all liability in this regard.

Patent documents cited in the description

- KR 1020080119142 [0001]
- JP 2001194645 B [0005]
- US 20060125981 A [0006]

专利名称(译)	液晶显示器		
公开(公告)号	EP2192440B1	公开(公告)日	2013-01-23
申请号	EP2009008027	申请日	2009-06-19
[标]申请(专利权)人(译)	三星电子株式会社		
申请(专利权)人(译)	SAMSUNG ELECTRONICS CO. , LTD.		
当前申请(专利权)人(译)	三星DISPLAY CO. , LTD.		
[标]发明人	LEE SANG DUK		
发明人	LEE, SANG-DUK		
IPC分类号	G02F1/1345 F21Y101/00		
CPC分类号	G02F1/133615 G02F1/134336 G02F1/13452 G02F1/13454		
代理机构(译)	韦策尔 , WOLFGANG		
优先权	1020080119142 2008-11-27 KR		
其他公开文献	EP2192440A1		
外部链接	Espacenet		

摘要(译)

液晶显示器包括：液晶面板，包括短边和长边；多条栅极线，设置在液晶面板上并且与液晶面板的短边基本平行地延伸；多条数据线，与所述液晶面板的短边绝缘。栅极线，与栅极线交叉并且基本上与液晶面板的长边平行地延伸，印刷电路板设置在液晶面板的一个短边附近并向液晶面板提供图像信号，与液晶面板重叠的导光板，向导光板提供光的光源模块和安装有光源模块的电路板。

