



(11) **EP 2 012 179 A1**

(12) **EUROPEAN PATENT APPLICATION**
published in accordance with Art. 153(4) EPC

(43) Date of publication:
07.01.2009 Bulletin 2009/02

(51) Int Cl.:
G02F 1/1368 (2006.01) G02F 1/1337 (2006.01)

(21) Application number: **07742316.8**

(86) International application number:
PCT/JP2007/058881

(22) Date of filing: **24.04.2007**

(87) International publication number:
WO 2007/123244 (01.11.2007 Gazette 2007/44)

(84) Designated Contracting States:
AT BE BG CH CY CZ DE DK EE ES FI FR GB GR HU IE IS IT LI LT LU LV MC MT NL PL PT RO SE SI SK TR
Designated Extension States:
AL BA HR MK RS

(72) Inventors:
• **SHORAKU, Akihiro**
Suzuka-shi,
MIE 513-0827 (JP)
• **TSUBATA, Toshhide**
Tsu-shi,
MIE 514-0003 (JP)

(30) Priority: **24.04.2006 JP 2006119419**
07.07.2006 JP 2006188645

(74) Representative: **Müller - Hoffmann & Partner**
Patentanwälte
Innere Wiener Strasse 17
81667 München (DE)

(71) Applicant: **Sharp Kabushiki Kaisha**
Osaka-shi, Osaka 545-8522 (JP)

(54) **LIQUID CRYSTAL DISPLAY DEVICE**

(57) Each pixel region includes two subpixel regions, in which different voltages are applied to a liquid crystal layer with respect to a signal voltage supplied from a source bus line by way of TFTs. A first substrate includes a first electrode provided for the two subpixel regions. A second substrate includes a second electrode that faces the first electrode with a vertical alignment liquid crystal layer interposed. A liquid crystal capacitor is provided for each of these subpixel regions. Each subpixel region includes at least one liquid crystal domain that produces a dark area, which looks darker than a gray scale tone being presented for a viewer located in front of the device, inside of, and substantially parallel to, an edge portion of the first electrode. At least a part of the edge portion of the first electrode is arranged so as to overlap with a gate bus line and selectively shield at least a part of the dark area. Two TFTs associated with the two subpixel regions have substantially equal drain-gate capacitances C_{gd} , thus providing a VA mode liquid crystal display device that achieves good display quality.

FIG. 22

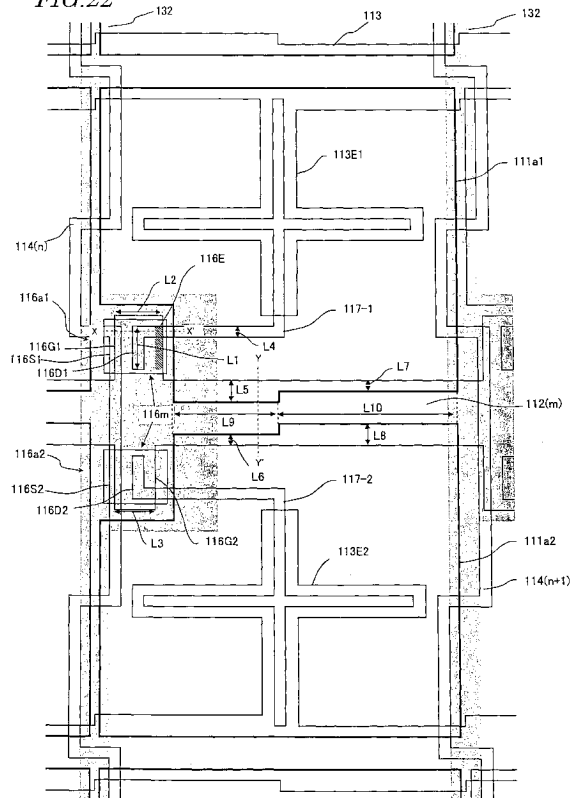

EP 2 012 179 A1

Description**TECHNICAL FIELD**

5 [0001] The present invention relates to a liquid crystal display device and more particularly relates to a liquid crystal display device with a wide viewing angle characteristic.

BACKGROUND ART

10 [0002] Recently, the display performances of liquid crystal displays (LCDs) have been improved to the point that more and more manufacturers adopt LCD panels as TV monitors, for example. The viewing angle characteristic of LCDs has been improved to a certain degree but not satisfactorily in some respects. Among other things, there is still a high demand for improvement of the viewing angle characteristic of an LCD using a vertical alignment liquid crystal layer (which is sometimes called a "VA mode LCD").

15 [0003] A VA mode LCD, which is currently used for a TV set with a big screen, for example, adopts a multi-domain structure, in which multiple liquid crystal domains are formed in a single pixel region, to improve the viewing angle characteristic. An MVA mode is often adopted as a method of forming such a multi-domain structure. Specifically, according to the MVA mode, an alignment control structure is provided on one of the two substrates, which face each other with a vertical alignment liquid crystal layer interposed between them, so as to contact with the liquid crystal layer, thereby forming multiple domains with mutually different alignment directions (i.e., tilt directions), the number of which is typically four. As the alignment control structure, a slit (as an opening) or a rib (as a projection structure) may be provided for an electrode, thereby creating an anchoring force from both sides of the liquid crystal layer.

20 [0004] If a slit or a rib is adopted, however, the anchoring force will be applied onto liquid crystal molecules non-uniformly within a pixel region because the slit or rib has a linear structure unlike the situation where the pretilt directions are defined by an alignment film in a conventional TN mode LCD. As a result, the response speed may have a distribution unintentionally. In addition, since the transmittance of light will decrease in the areas with the slits or ribs, the luminance on the screen will decrease, too.

25 **Patent Document No. 1:** Japanese Patent Application Laid-Open Publication No. 11-133429

30 **Patent Document No. 2:** Japanese Patent Application Laid-Open Publication No. 11-352486

DISCLOSURE OF INVENTION**PROBLEMS TO BE SOLVED BY THE INVENTION**

35 [0005] To avoid such a problem, the multi-domain structure is preferably formed by defining the pretilt directions with an alignment film for a VA mode LCD, too. Thus, the present inventors discovered and confirmed via experiments that a unique misalignment occurred in a VA mode LCD and affected its display quality.

40 [0006] Even in a conventional LCD in which the multi-domain structure is formed using an alignment film, a technique for providing an opaque portion for cutting the light that has been transmitted through an area with misalignment to minimize the deterioration in display quality due to the misalignment is also known (see Patent Document No. 1, for example).

45 [0007] The conventional multi-domain structure is provided with such an opaque portion to shield an area with an optical transmittance that is higher than a predetermined value (i.e., an area that looks brighter when viewed straight than an area where liquid crystal molecules are aligned normally) due to a misalignment such as a reverse tilt in a TN mode LCD, for example. However, the present inventors discovered that the display quality of a VA mode LCD could not be improved sufficiently just by shielding such an area that looked brighter when viewed straight than an area where liquid crystal molecules were aligned normally.

50 [0008] In order to overcome the problems described above, the present invention has an object of providing a VA mode liquid crystal display device with excellent display quality.

MEANS FOR SOLVING THE PROBLEMS

55 [0009] A liquid crystal display device is characterized by including: a vertical alignment liquid crystal layer; a first substrate and a second substrate, which face each other with the liquid crystal layer interposed between them; and at least one alignment film, which is arranged in contact with the liquid crystal layer. The first substrate includes a TFT, a gate bus line, a source bus line and a storage capacitor line. Each pixel region includes two subpixel regions, in which mutually different voltages are applied to the liquid crystal layer with respect to a signal voltage that has been supplied

from the source bus line by way of their associated TFTs. The first substrate further includes a first electrode, which is provided for each of the two subpixel regions. The second substrate includes a second electrode, which is arranged so as to face the first electrode with the liquid crystal layer interposed between them. A liquid crystal capacitor, formed by the first and second electrodes and the liquid crystal layer between the first and second electrodes, is provided for each said subpixel region. Each said subpixel region includes at least one liquid crystal domain that produces a dark area, which looks darker than a gray scale tone being presented for a viewer located in front of the device, inside of, and substantially parallel to, an edge portion of the first electrode. At least a part of the edge portion of the first electrode is arranged so as to overlap with the gate bus line and selectively shield at least a part of the dark area from incoming light. Two TFTs associated with the two subpixel regions have substantially equal drain-gate capacitances C_{gd} .

[0010] In one preferred embodiment, the gate electrodes of the two TFTs associated with the two subpixel regions have mutually different areas.

[0011] In another preferred embodiment, the drain electrodes of the two TFTs associated with the two subpixel regions have mutually different areas.

[0012] In still another preferred embodiment, a portion of the first electrode overlapping with the gate bus line, including the edge portion, in one of the two subpixel regions has a different area from the overlapping portion of the first electrode in the other subpixel region.

[0013] In an alternative preferred embodiment, a portion of the first electrode overlapping with the gate bus line, including the edge portion, in one of the two subpixel regions has the same area as the overlapping portion of the first electrode in the other subpixel region.

[0014] In yet another preferred embodiment, the liquid crystal display device further includes: drain extension lines, which are connected to the respective drains of the two TFTs associated with the two subpixel regions; and gate bus line extended portions, which branch from the gate bus line. Each gate bus line extended portion includes a portion that faces its associated drain extension line that is connected to one of the two TFTs with an insulating layer interposed between them.

[0015] In this particular preferred embodiment, each of the two subpixel regions further includes first, second, third and fourth liquid crystal domains in which liquid crystal molecules are tilted in first, second, third and fourth directions, respectively, around the center of the plane, and approximately at the middle of the thickness, of the liquid crystal layer in response to a voltage applied. The first, second, third and fourth directions are defined such that an angle formed between any two of the four directions is approximately equal to an integral multiple of 90 degrees. The first liquid crystal domain is located close to at least a part of an edge of the first electrode, and the part includes a first edge portion in which an azimuthal direction that is perpendicular to the part and that points toward the inside of the first electrode defines an angle greater than 90 degrees with respect to the first direction. The second liquid crystal domain is located close to at least a part of another edge of the first electrode, and the part includes a second edge portion in which an azimuthal direction that is perpendicular to the part and that points toward the inside of the first electrode defines an angle greater than 90 degrees with respect to the second direction. The third liquid crystal domain is located close to at least a part of still another edge of the first electrode, and the part includes a third edge portion in which an azimuthal direction that is perpendicular to the part and that points toward the inside of the first electrode defines an angle greater than 90 degrees with respect to the third direction. The fourth liquid crystal domain is located close to at least a part of yet another edge of the first electrode, and the part includes a fourth edge portion in which an azimuthal direction that is perpendicular to the part and that points toward the inside of the first electrode defines an angle greater than 90 degrees with respect to the fourth direction. Either the first or second substrate has an opaque member that includes first, second, third and fourth opaque portions for selectively shielding at least respective parts of the first, second, third and fourth edge portions from incoming light, and a central opaque portion for shielding at least a part of a boundary area, where each of the first, second, third and fourth liquid crystal domains is adjacent to another one of these four liquid crystal domains, from incoming light. The central opaque portion includes a part of the drain extension line.

[0016] In a specific preferred embodiment, if the horizontal direction of a display screen has an azimuthal angle of zero degrees, the first, second, third and fourth directions are an approximately 225 degree direction, an approximately 315 degree direction, an approximately 45 degree direction and an approximately 135 degree direction, respectively. The first and third edge portions are parallel to a vertical direction and the second and fourth edge portions are parallel to the horizontal direction. In one of the two subpixel regions, the third opaque portion includes at least a part of the gate bus line extended portion.

[0017] In another preferred embodiment, in one of the two subpixel regions, the first opaque portion includes at least a part of the storage capacitor line extended portion.

[0018] In still another preferred embodiment, in the other subpixel region, the third opaque portion includes at least a part of the storage capacitor line extended portion.

[0019] In yet another preferred embodiment, in the other subpixel region, the first opaque portion includes at least a part of an island opaque portion that is made of the same layer as the gate bus line.

[0020] In yet another preferred embodiment, the feedthrough voltages of the two subpixel regions have a difference

of 100 mV or less.

5 [0021] Another liquid crystal display device according to the present invention is characterized by including: a vertical alignment liquid crystal layer; a first substrate and a second substrate, which face each other with the liquid crystal layer interposed between them; a first electrode, which is arranged on the first substrate so as to face the liquid crystal layer; a second electrode, which is arranged on the second substrate so as to face the liquid crystal layer; and at least one alignment film, which is arranged in contact with the liquid crystal layer. A pixel region includes at least one liquid crystal domain that produces a dark area, which looks darker than a gray scale tone being presented for a viewer located in front of the device, inside of, and substantially parallel to, an edge portion of the first electrode. Either the first substrate or the second substrate has an opaque member that includes at least one opaque portion for selectively shielding the dark area from incoming light.

10 [0022] Another liquid crystal display device according to the present invention is characterized by including: a vertical alignment liquid crystal layer; a first substrate and a second substrate, which face each other with the liquid crystal layer interposed between them; a first electrode, which is arranged on the first substrate so as to face the liquid crystal layer; a second electrode, which is arranged on the second substrate so as to face the liquid crystal layer; and at least one alignment film, which is arranged in contact with the liquid crystal layer. A pixel region includes a first liquid crystal domain in which liquid crystal molecules are tilted in a predetermined first direction around the center of a plane, and approximately at the middle of the thickness, of the liquid crystal layer in response to a voltage applied. The first liquid crystal domain is located close to at least a part of an edge of the first electrode. The part includes a first edge portion in which an azimuthal direction that is perpendicular to the part and that points toward the inside of the first electrode defines an angle greater than 90 degrees with respect to the first direction. Either the first substrate or the second substrate has an opaque member that includes a first opaque portion for selectively shielding at least one a part of the first edge portion from incoming light.

20 [0023] In one preferred embodiment, the pixel region further includes second, third and fourth liquid crystal domains in which liquid crystal molecules are tilted in second, third and fourth directions, respectively, around the center of the plane, and approximately at the middle of the thickness, of the liquid crystal layer in response to the voltage applied. The first, second, third and fourth directions are defined such that an angle formed between any two of the four directions is approximately equal to an integral multiple of 90 degrees. The second liquid crystal domain is located close to at least a part of another edge of the first electrode, and the part includes a second edge portion in which an azimuthal direction that is perpendicular to the part and that points toward the inside of the first electrode defines an angle greater than 90 degrees with respect to the second direction. The third liquid crystal domain is located close to at least a part of still another edge of the first electrode, and the part includes a third edge portion in which an azimuthal direction that is perpendicular to the part and that points toward the inside of the first electrode defines an angle greater than 90 degrees with respect to the third direction. The fourth liquid crystal domain is located close to at least a part of yet another edge of the first electrode, and the part includes a fourth edge portion in which an azimuthal direction that is perpendicular to the part and that points toward the inside of the first electrode defines an angle greater than 90 degrees with respect to the fourth direction. The opaque member further includes second, third and fourth opaque portions for selectively shielding at least respective parts of the second, third and fourth edge portions, respectively, from incoming light.

30 [0024] In this particular preferred embodiment, the first, second, third and fourth liquid crystal domains are arranged such that the tilt directions of any two adjacent ones of the liquid crystal domains define an angle of approximately 90 degrees between them.

35 [0025] In a specific preferred embodiment, if the horizontal direction of a display screen has an azimuthal angle of zero degrees, the first, second, third and fourth directions are an approximately 225 degree direction, an approximately 315 degree direction, an approximately 45 degree direction and an approximately 135 degree direction, respectively. The first and third edge portions are parallel to a vertical direction and the second and fourth edge portions are parallel to the horizontal direction.

40 [0026] In an alternative preferred embodiment, if the horizontal direction of a display screen has an azimuthal angle of zero degrees, the first, second, third and fourth directions are an approximately 225 degree direction, an approximately 315 degree direction, an approximately 45 degree direction and an approximately 135 degree direction, respectively. The first and third edge portions are parallel to the horizontal direction and the second and fourth edge portions are parallel to a vertical direction.

45 [0027] In another alternative preferred embodiment, if the horizontal direction of a display screen has an azimuthal angle of zero degrees, the first, second, third and fourth directions are an approximately 225 degree direction, an approximately 315 degree direction, an approximately 45 degree direction and an approximately 135 degree direction, respectively. Each of the first, second, third and fourth edge portions includes a first part that is parallel to the horizontal direction and a second part that is parallel to a vertical direction.

50 [0028] In another preferred embodiment, the pixel region further includes second, third and fourth liquid crystal domains in which liquid crystal molecules are tilted in second, third and fourth directions, respectively, around the center of the plane, and approximately at the middle of the thickness, of the liquid crystal layer in response to the voltage applied.

The first, second, third and fourth directions are defined such that an angle formed between any two of the four directions is approximately equal to an integral multiple of 90 degrees. The first and second directions form an angle of approximately 180 degrees between them. The second liquid crystal domain is located close to at least a part of another edge of the first electrode, and the part includes a second edge portion in which an azimuthal direction that is perpendicular to the part and that points toward the inside of the first electrode defines an angle greater than 90 degrees with respect to the second direction. Each of the first and second edge portions includes a first part that is parallel to the horizontal direction and a second part that is parallel to a vertical direction. And the opaque member further includes a second opaque portion for selectively shielding at least a part of the second edge portion from incoming light.

[0029] In a specific preferred embodiment, if the horizontal direction on the display screen has an azimuthal angle of zero degrees, the first direction is either an approximately 135 degree direction or an approximately 225 degree direction.

[0030] In another preferred embodiment, if the horizontal direction of a display screen has an azimuthal angle of zero degrees, the first, second, third and fourth directions are an approximately 90 degree direction, an approximately 180 degree direction, an approximately 0 degree direction and an approximately 270 degree direction, respectively. The first and fourth edge portions are parallel to the horizontal direction and the second and third edge portions are parallel to a vertical direction.

[0031] In still another preferred embodiment, if the horizontal direction of a display screen has an azimuthal angle of zero degrees, the first, second, third and fourth directions are an approximately 225 degree direction, an approximately 315 degree direction, an approximately 45 degree direction and an approximately 135 degree direction, respectively. The first, second, third and fourth edge portions are all parallel to a vertical direction.

[0032] In yet another preferred embodiment, the opaque member includes a central opaque portion for selectively shielding at least a portion of a boundary area of each of the first, second, third and fourth liquid crystal domains, which is adjacent to another one of the liquid crystal domains, from incoming light.

[0033] In yet another preferred embodiment, the opaque member includes another opaque portion for shielding an intersection between a boundary area of each of the first, second, third and fourth liquid crystal domains, which is adjacent to another one of the liquid crystal domains, and one of the first, second, third and fourth edge portions from incoming light.

[0034] In yet another preferred embodiment, the first substrate further includes a TFT, a gate bus line, a source bus line, a drain extension line, and a storage capacitor line. One of the first, second, third, fourth, central and another opaque portions is defined by at least a portion of at least one line selected from the group consisting of the gate bus line, the source bus line, the drain extension line, and the storage capacitor line.

[0035] In this particular preferred embodiment, the at least one line has a portion that is bent or broadened in a direction that crosses its length direction, and the at least the portion of the at least one line includes at least a part of the bent or broadened portion.

[0036] In yet another preferred embodiment, the second substrate further includes a black matrix layer, and one of the first, second, third, fourth, central and another opaque portions is defined by a portion of the black matrix layer.

[0037] In yet another preferred embodiment, the liquid crystal display device further includes two polarizers, which are arranged so as to face each other with the liquid crystal layer interposed between them and to have their transmission axes crossed at right angles. The first, second, third and fourth directions define an angle of approximately 45 degrees with respect to the transmission axes of the two polarizers.

[0038] In yet another preferred embodiment, the vertical alignment liquid crystal layer includes a liquid crystal material with negative dielectric anisotropy. The at least one alignment film includes two alignment films that are arranged so as to sandwich the liquid crystal layer between them. Respective pretilt directions defined by the two alignment films are different from each other by approximately 90 degrees.

[0039] In yet another preferred embodiment, the at least one alignment film includes two alignment films that are arranged so as to sandwich the liquid crystal layer between them. Respective pretilt angles defined by the two alignment films are substantially equal to each other.

[0040] In yet another preferred embodiment, the at least one alignment film is an optical alignment film.

[0041] Still another liquid crystal display device according to the present invention includes: a vertical alignment liquid crystal layer; a first substrate and a second substrate, which face each other with the liquid crystal layer interposed between them; a first electrode, which is arranged on the first substrate so as to face the liquid crystal layer; a second electrode, which is arranged on the second substrate so as to face the liquid crystal layer; and at least one alignment film, which is arranged in contact with the liquid crystal layer. A pixel region includes first, second, third and fourth liquid crystal domains in which liquid crystal molecules are tilted in first, second, third and fourth directions, respectively, around the center of a plane, and approximately at the middle of the thickness, of the liquid crystal layer in response to a voltage applied. The first, second, third and fourth directions are defined such that an angle formed between any two of the four directions is approximately equal to an integral multiple of 90 degrees. Each of the first, second, third and fourth liquid crystal domains is adjacent to another one of the liquid crystal domains. An opaque member includes a central opaque portion for selectively shielding at least a portion of a boundary area of each of the first, second, third and fourth liquid crystal domains, which is adjacent to another one of the liquid crystal domains, from incoming light.

5 [0042] In one preferred embodiment, the first liquid crystal domain is located close to at least a part of an edge of the first electrode, and the part includes a first edge portion in which an azimuthal direction that is perpendicular to the part and that points toward the inside of the first electrode defines an angle greater than 90 degrees with respect to the first direction. The second liquid crystal domain is located close to at least a part of another edge of the first electrode, and the part includes a second edge portion in which an azimuthal direction that is perpendicular to the part and that points toward the inside of the first electrode defines an angle greater than 90 degrees with respect to the second direction. The third liquid crystal domain is located close to at least a part of still another edge of the first electrode, and the part includes a third edge portion in which an azimuthal direction that is perpendicular to the part and that points toward the inside of the first electrode defines an angle greater than 90 degrees with respect to the third direction. The fourth liquid crystal domain is located close to at least a part of yet another edge of the first electrode, and the part includes a fourth edge portion in which an azimuthal direction that is perpendicular to the part and that points toward the inside of the first electrode defines an angle greater than 90 degrees with respect to the fourth direction.

10 [0043] In another preferred embodiment, the first, second, third and fourth liquid crystal domains are arranged in two rows and two columns so as to define a matrix pattern.

15 [0044] In an alternative preferred embodiment, the first, second, third and fourth liquid crystal domains are arranged in line in a predetermined direction.

20 [0045] In still another preferred embodiment, the first substrate further includes a TFT, a gate bus line, a source bus line, a drain extension line, and a storage capacitor line, and the central opaque portion is defined by at least a portion of at least one line selected from the group consisting of the gate bus line, the source bus line, the drain extension line, and the storage capacitor line.

[0046] In this particular preferred embodiment, the at least one line has a portion that is bent or broadened in a direction that crosses its length direction, and the at least the portion of the at least one line includes at least a part of the bent or broadened portion. In yet another preferred embodiment, the second substrate further includes a black matrix layer, and the central opaque portion is defined by a portion of the black matrix layer.

25 [0047] In yet another preferred embodiment, the liquid crystal display device further includes two polarizers, which are arranged so as to face each other with the liquid crystal layer interposed between them and to have their transmission axes crossed at right angles. The first, second, third and fourth directions define an angle of approximately 45 degrees with respect to the transmission axes of the two polarizers.

30 [0048] In yet another preferred embodiment, the vertical alignment liquid crystal layer includes a liquid crystal material with negative dielectric anisotropy. The at least one alignment film includes two alignment films that are arranged so as to sandwich the liquid crystal layer between them. Respective pretilt directions defined by the two alignment films are different from each other by approximately 90 degrees.

35 [0049] In yet another preferred embodiment, the at least one alignment film includes two alignment films that are arranged so as to sandwich the liquid crystal layer between them, and respective pretilt angles defined by the two alignment films are substantially equal to each other.

[0050] In yet another preferred embodiment, the at least one alignment film is an optical alignment film.

40 [0051] Yet another liquid crystal display device according to the present invention includes: a vertical alignment liquid crystal layer; a first substrate and a second substrate, which face each other with the liquid crystal layer interposed between them; a first electrode, which is arranged on the first substrate so as to face the liquid crystal layer; a second electrode, which is arranged on the second substrate so as to face the liquid crystal layer; and at least one alignment film, which is arranged in contact with the liquid crystal layer. A pixel region includes first, second, third and fourth liquid crystal domains in which liquid crystal molecules are tilted in first, second, third and fourth directions, respectively, around the center of a plane, and approximately at the middle of the thickness, of the liquid crystal layer in response to a voltage applied. The first, second, third and fourth directions are defined such that an angle formed between any two of the four directions is approximately equal to an integral multiple of 90 degrees. The first liquid crystal domain is located close to at least a part of an edge of the first electrode, and the part includes a first edge portion in which an azimuthal direction that is perpendicular to the part and that points toward the inside of the first electrode defines an angle greater than 90 degrees with respect to the first direction. The second liquid crystal domain is located close to at least a part of another edge of the first electrode, and the part includes a second edge portion in which an azimuthal direction that is perpendicular to the part and that points toward the inside of the first electrode defines an angle greater than 90 degrees with respect to the second direction. The third liquid crystal domain is located close to at least a part of still another edge of the first electrode, and the part includes a third edge portion in which an azimuthal direction that is perpendicular to the part and that points toward the inside of the first electrode defines an angle greater than 90 degrees with respect to the third direction. The fourth liquid crystal domain is located close to at least a part of yet another edge of the first electrode, and the part includes a fourth edge portion in which an azimuthal direction that is perpendicular to the part and that points toward the inside of the first electrode defines an angle greater than 90 degrees with respect to the fourth direction. Each of the first, second, third and fourth liquid crystal domains is adjacent to another one of the liquid crystal domains. Either the first substrate or the second substrate includes an opaque member, which includes an opaque portion for shielding

an intersection between a boundary area of each of the first, second, third and fourth liquid crystal domains, which is adjacent to another one of the liquid crystal domains, and one of the first, second, third and fourth edge portions from incoming light.

5 [0052] In one preferred embodiment, the first, second, third and fourth liquid crystal domains are arranged such that the tilt directions of any two adjacent ones of the liquid crystal domains define an angle of approximately 90 degrees between them.

[0053] In a specific preferred embodiment, if the horizontal direction of a display screen has an azimuthal angle of zero degrees, the first, second, third and fourth directions are an approximately 225 degree direction, an approximately 315 degree direction, an approximately 45 degree direction and an approximately 135 degree direction, respectively.
10 The first and third edge portions are parallel to a vertical direction and the second and fourth edge portions are parallel to the horizontal direction.

[0054] In an alternative preferred embodiment, if the horizontal direction of a display screen has an azimuthal angle of zero degrees, the first, second, third and fourth directions are an approximately 225 degree direction, an approximately 315 degree direction, an approximately 45 degree direction and an approximately 135 degree direction, respectively.
15 The first and third edge portions are parallel to the horizontal direction and the second and fourth edge portions are parallel to a vertical direction.

[0055] In another alternative preferred embodiment, if the horizontal direction of a display screen has an azimuthal angle of zero degrees, the first, second, third and fourth directions are an approximately 90 degree direction, an approximately 180 degree direction, an approximately 0 degree direction and an approximately 270 degree direction, respectively.
20 The first and fourth edge portions are parallel to the horizontal direction and the second and third edge portions are parallel to a vertical direction.

[0056] In still another alternative preferred embodiment, if the horizontal direction of a display screen has an azimuthal angle of zero degrees, the first, second, third and fourth directions are an approximately 225 degree direction, an approximately 315 degree direction, an approximately 45 degree direction and an approximately 135 degree direction, respectively.
25 The first, second, third and fourth edge portions are all parallel to a vertical direction.

[0057] In yet another preferred embodiment, the opaque portion is substantially triangular.

[0058] In yet another preferred embodiment, an opaque member includes a central opaque portion for selectively shielding at least a portion of a boundary area of each of the first, second, third and fourth liquid crystal domains, which is adjacent to another one of the liquid crystal domains, from incoming light.

30 [0059] In yet another preferred embodiment, the first substrate further includes a TFT, a gate bus line, a source bus line, a drain extension line, and a storage capacitor line. Either the opaque portion or the central opaque portion is defined by at least a portion of at least one line selected from the group consisting of the gate bus line, the source bus line, the drain extension line, and the storage capacitor line.

[0060] In yet another preferred embodiment, the second substrate further includes a black matrix layer, and either the opaque portion or the central opaque portion is defined by a portion of the black matrix layer.
35

[0061] In yet another preferred embodiment, the liquid crystal display device further includes two polarizers, which are arranged so as to face each other with the liquid crystal layer interposed between them and to have their transmission axes crossed at right angles. The first, second, third and fourth directions define an angle of approximately 45 degrees with respect to the transmission axes of the two polarizers.

40 [0062] In yet another preferred embodiment, the vertical alignment liquid crystal layer includes a liquid crystal material with negative dielectric anisotropy, and the at least one alignment film includes two alignment films that are arranged so as to sandwich the liquid crystal layer between them. The pretilt direction defined by one of the two alignment films is different from that defined by the other alignment film by approximately 90 degrees.

[0063] In yet another preferred embodiment, the at least one alignment film includes two alignment films that are arranged so as to sandwich the liquid crystal layer between them, and respective pretilt angles defined by the two alignment films are substantially equal to each other.
45

[0064] In yet another preferred embodiment, the at least one alignment film is an optical alignment film.

EFFECTS OF THE INVENTION

50 [0065] According to the present invention, the display quality of a VA mode liquid crystal display device can be improved in terms of its viewing angle dependence, in particular. Also, according to the present invention, the display quality of a liquid crystal display device having a multi-domain structure defined by an alignment film can be improved.

55 BRIEF DESCRIPTION OF DRAWINGS

[0066]

FIG. 1 illustrates an exemplary pixel region with a multi-domain structure in a VA mode liquid crystal display device according to the present invention.

Portions (a) and (b) of FIG. 2 illustrate an exemplary pixel region with a multi-domain structure in a VA mode liquid crystal display device according to the present invention.

5 Portions (a) and (b) of FIG. 3 illustrate another exemplary pixel region with a multi-domain structure in a VA mode liquid crystal display device according to the present invention.

Portions (a) and (b) of FIG. 4 illustrate still another exemplary pixel region with a multi-domain structure in a VA mode liquid crystal display device according to the present invention.

10 FIGS. 5(a) and 5(b) illustrate yet another exemplary pixel region with a multi-domain structure in a VA mode liquid crystal display device according to the present invention.

FIG. 6 is a cross-sectional view of a pixel region of a VA mode liquid crystal display device according to the present invention, showing the equipotential curve of an electric field created in the liquid crystal layer, the orientation directions of liquid crystal molecules in the layer, and the transmittance thereof, which were figured out by simulations.

15 FIG. 7 is a cross-sectional view of a pixel region of a VA mode liquid crystal display device according to the present invention, showing the equipotential curve of an electric field created in the liquid crystal layer, the orientation directions of liquid crystal molecules in the layer, and the transmittance thereof, which were figured out by simulations.

FIG. 8 is a cross-sectional view of a pixel region of a VA mode liquid crystal display device according to the present invention, showing the equipotential curve of an electric field created in the liquid crystal layer, the orientation directions of liquid crystal molecules in the layer, and the transmittance thereof, which were figured out by simulations.

20 FIG. 9 is a cross-sectional view of a pixel region of a VA mode liquid crystal display device according to the present invention, showing the equipotential curve of an electric field created in the liquid crystal layer, the orientation directions of liquid crystal molecules in the layer, and the transmittance thereof, which were figured out by simulations.

FIG. 10 is graphs showing the distributions of transmission intensities in a situation where the pixel region shown in portion (a) of FIG. 2 is viewed from the direction defined by an azimuth angle of 45 degrees.

25 FIG. 11 is a schematic representation illustrating an exemplary pixel structure for a liquid crystal display device according to the present invention.

FIG. 12 is a schematic representation illustrating another exemplary pixel structure for a liquid crystal display device according to the present invention.

30 FIG. 13 is a schematic representation illustrating still another exemplary pixel structure for a liquid crystal display device according to the present invention.

FIG. 14 is a schematic representation illustrating yet another exemplary pixel structure for a liquid crystal display device according to the present invention.

FIG. 15 is a cross-sectional view schematically illustrating the pixel structure shown in FIG. 14.

35 FIG. 16 is a schematic representation illustrating yet another exemplary pixel structure for a liquid crystal display device according to the present invention.

FIG. 17 is a cross-sectional view schematically illustrating the pixel structure shown in FIG. 16.

FIG. 18 is a schematic representation illustrating yet another exemplary pixel structure for a liquid crystal display device according to the present invention.

40 FIG. 19 is a schematic representation illustrating yet another exemplary pixel structure for a liquid crystal display device according to the present invention.

FIG. 20 is a schematic representation showing another area in which misalignment occurs in a pixel region with a multi-domain structure in a VA mode liquid crystal display device according to the present invention.

FIG. 21 is a schematic representation illustrating yet another exemplary pixel structure for a liquid crystal display device according to the present invention.

45 FIG. 22 is a schematic representation illustrating yet another exemplary pixel structure for a liquid crystal display device according to the present invention.

FIG. 23(a) is a schematic cross-sectional view as viewed on the plane X-X' shown in FIG. 22 and FIG. 23(b) is a schematic cross-sectional view as viewed on the plane Y-Y' shown in FIG. 22.

FIG. 24 is an equivalent circuit diagram of a pixel having the multi-domain pixel structure shown in FIG. 22.

50 FIG. 25 is an enlarged view of a portion of the multi-domain pixel structure shown in FIG. 22 where Cgd is produced.

FIG. 26 is a schematic representation illustrating another exemplary pixel structure for a liquid crystal display device according to the present invention.

FIG. 27 is a schematic representation illustrating still another exemplary pixel structure for a liquid crystal display device according to the present invention.

55 FIG. 28 is a schematic representation illustrating yet another exemplary pixel structure for a liquid crystal display device according to the present invention.

FIG. 29 is a schematic representation illustrating yet another exemplary pixel structure for a liquid crystal display device according to the present invention.

DESCRIPTION OF REFERENCE NUMERALS

[0067]

5	1	TFT substrate
	1a, 2a	transparent substrate
	2	CF substrate
	3	liquid crystal layer
	3a	liquid crystal molecule
10	10	pixel region
	11	pixel electrode
	12	counter electrode
	111	pixel electrode
	111a, 111a1, 111a2	subpixel electrode
15	111a1E	111E broadened portion of pixel electrode or subpixel electrode broadened portion of subpixel electrode
	112	gate bus line
	112E1, 112E2	extended portion of gate bus line
	113	CS bus line (storage capacitor line)
	113E, 113E1, 113E2	extended portion of CS bus line
20	114	source bus line
	115	gate insulating film
	116, 116a, 116b, 116a1, 116a2	TFT
	116m	semiconductor layer (i-layer)
	116D, 116D1, 116D2	drain electrode
25	116G, 116G1, 116G2	gate electrode
	116S, 116S1, 116S2	source electrode
	117, 117-1, 117-2	drain extension line
	117E	extended portion of drain extension line
	118a	passivation film
30	118b	interlayer dielectric film
	132	black matrix
	SD1 to SD4	edges of pixel electrode
	EG1 to EG4	edge portions of pixel electrode
	A to D	liquid crystal domain
35	t1 to t4	tilt direction (reference alignment direction)
	e1 to e4	azimuth direction that is perpendicular to edge of pixel electrode and pointed inward in pixel electrode

BEST MODE FOR CARRYING OUT THE INVENTION

40 **[0068]** Hereinafter, preferred embodiments of a liquid crystal display device according to the present invention will be described with reference to the accompanying drawings. However, the present invention is in no way limited to the following specific preferred embodiments. According to the present invention, a liquid crystal display device, including a vertical alignment liquid crystal layer of which the pretilt direction is controlled by using at least one alignment film, has its display quality improved by providing an opaque film where misalignment occurs.

45 **[0069]** The display quality is affected to different degrees depending on where misalignment has occurred. That is why the type of misalignment to be hidden behind an opaque portion also changes with the display performance required. In the following description, three types of misalignment to occur in three different locations in a pixel region (namely, an electrode edge portion, a central portion and an intersection portion) will be described separately. These three locations may be shielded independently of each other. Two or more of these locations may be shielded in any arbitrary combination or all of them may be shielded, too.

50 **[0070]** As used herein, the "vertical alignment liquid crystal layer" means a liquid crystal layer in which the axis of liquid crystal molecules (which will be sometimes referred to herein as an "axis direction") defines a tilt angle of approximately 85 degrees or more with respect to the surface of a vertical alignment film. The liquid crystal molecules have negative dielectric anisotropy and are combined with polarizers that are arranged as crossed Nicols to conduct a display operation in normally black mode. The alignment film may be provided for at least one of the two substrates. However, to stabilize the alignment, each of the two substrates is preferably provided with an alignment film. In the preferred embodiment to be described below, each of the two substrates is provided with a vertical alignment film. Also, since every misalignment

occurs within the multi-domain structure except that occurring in an electrode edge portion, a four-domain structure that realizes a particularly good viewing angle characteristic will be described as an example. As used herein, the "pixel" refers to a minimum unit for representing a particular gray scale tone on the screen, and corresponds to a unit for representing each gray scale tone of red (R), green (G) and blue (B) in color display and is also called a "dot". A combination of R, G and B pixels forms a single color display pixel. The "pixel region" refers to a region of a liquid crystal display device that is allocated to a single "pixel" on the screen. The "pretilt direction" is the orientation direction of liquid crystal molecules to be controlled with an alignment film and refers to an azimuthal direction on a display screen. Also, the angle formed by the liquid crystal molecules with respect to the surface of the alignment film in this case will be referred to herein as a "pretilt angle". The pretilt direction will be defined by subjecting the alignment film to a rubbing treatment or an optical alignment treatment. By changing the combinations of the pretilt directions of the two alignment films that face each other with the liquid crystal layer interposed between them, the four-domain structure can be formed. The quadruple pixel region includes four liquid crystal domains (which will be sometimes simply referred to herein as "domains"). Each of these liquid crystal domains is characterized by the tilt direction of liquid crystal molecules at the center of a plane of the liquid crystal layer, to which a voltage is being applied, and at the middle of the thickness of the liquid crystal layer. Such a tilt direction will be sometimes referred to herein as a "reference alignment direction". And this tilt direction (or reference alignment direction) will have an important effect on the viewing angle dependence of each domain. The tilt direction is also an azimuthal direction. The reference azimuthal direction is supposed to be the horizontal direction on the screen and the azimuth angle is supposed to increase counterclockwise. For example, comparing the display screen to a clock face, the three o'clock direction is supposed to have an azimuth angle of zero degrees and the angle is supposed to increase counterclockwise. By defining the tilt directions of the four liquid crystal domains such that an angle formed between any two of the four directions is approximately equal to an integral multiple of 90 degrees (e.g., as the twelve o'clock direction, the nine o'clock direction, the six o'clock direction and the three o'clock direction, respectively), highly uniform viewing angle characteristic and good display quality are realized. To increase the uniformity of the viewing angle characteristic, the areas of those four liquid crystal domains in the pixel region are preferably equalized with each other. Specifically, the difference between the area of the largest one of the four liquid crystal domains and that of the smallest one of the four is preferably no greater than 25% of the largest area.

[0071] The vertical alignment liquid crystal layer of the preferred embodiment to be described below includes a nematic liquid crystal material with negative dielectric anisotropy. The pretilt directions defined by the two alignment films that sandwich the liquid crystal layer between them are different from each other by approximately 90 degrees. The tilt angle (i.e., the reference alignment direction) is defined as an intermediate direction between these two pretilt directions. No chiral agent is added to the liquid crystal layer. And when a voltage is applied to the liquid crystal layer, the liquid crystal molecules located near the alignment films will have a twisted alignment under the anchoring force of the alignment films. If necessary, a chiral agent may be added to the liquid crystal layer. By using such a pair of vertical alignment films defining two pretilt directions (alignment treatment directions) that are perpendicular to each other, the VA mode in which the liquid crystal molecules have a twisted alignment is sometimes called a vertical alignment twisted nematic (VATN) mode (see Patent Document No. 2, for example).

[0072] In the VATN mode, the pretilt angles defined by the two alignment films are preferably substantially equal to each other as disclosed by the applicant of the present application in Japanese Patent Application No. 2005-141846. By using such a pair of alignment films defining pretilt angles that are approximately equal to each other, the display luminance can be increased. Particularly when the difference between the pretilt angles defined by the two alignment films is within one degree, the tilt direction (i.e., the reference alignment direction) of liquid crystal molecules, located approximately at the middle of the thickness of the liquid crystal layer, can be controlled with good stability and the display luminance can be increased. This is probably because if the difference between the pretilt angles were more than one degree, then the tilt direction would vary noticeably from one location to another in the liquid crystal layer and the transmittance would vary significantly as a result (i.e., some area would have a lower transmittance than a desired one).

[0073] According to known methods, the pretilt direction of liquid crystal molecules may be defined by alignment films by subjecting the alignment films to a rubbing treatment or an optical alignment treatment, by forming a microstructure on an undercoat film for each alignment film and transferring the pattern of the microstructure onto the surface of the alignment film, or by evaporating obliquely an inorganic material such as SiO on an alignment film to define a microstructure thereon. Considering its mass productivity, either the rubbing treatment or the optical alignment treatment is preferred. Among other things, the optical alignment treatment is particularly preferred to increase the yield because that treatment is a non-contact method and generates no static electricity due to friction unlike the rubbing treatment. Also, as described in Japanese Patent Application No. 2005-141846 mentioned above, by using an optical alignment film including a photosensitive group, the variation in pretilt angle can be reduced to one degree or less. The optical alignment film preferably includes at least one photosensitive group selected from the group consisting of a 4-chalcone group, a 4'-chalcone group, a coumarin group, and a cinnamoyl group to name a few.

[0074] The preferred embodiment to be described below is a TFT LCD as a typical example. However, the present invention is naturally applicable for use in a liquid crystal display device that adopts any other driving method.

Edge portion and central portion

[0075] First, misalignment that may occur in an electrode edge portion will be described.

[0076] The present inventors discovered that when a voltage was applied to a liquid crystal display device including a vertical alignment liquid crystal layer, of which the pretilt direction was controlled using an alignment film, to present a gray scale tone thereon, an area, which looked darker than the gray scale tone being presented when viewed straight, appeared inside of, and substantially parallel to, an edge portion of a pixel electrode. In the multi-domain structure, if at any of the edges of a pixel electrode, to which a liquid crystal domain is located close, the azimuthal direction that is perpendicular to the edge and that points toward the inside of the pixel electrode defines an angle greater than 90 degrees with respect to the tilt direction (i.e., the reference alignment direction) of the liquid crystal domain, the area that looks darker than the gray scale tone being presented will appear inside of, and substantially parallel to, that edge. The alignment state of the liquid crystal molecules will be disturbed in that area probably because the tilt direction of the liquid crystal domain and the direction in which the anchoring force is produced by an oblique electric field at the edge of the pixel electrode have opposing components.

[0077] As used herein, the "gray scale tone" refers to any tone except black (i.e., the lowest tone) and white (i.e., the highest tone). The dark area always appears when a non-black gray scale tone (including white) is presented as a matter of principle. However, the dark area is easier to perceive at a relatively high gray scale tone. Also, unless a particular viewing direction is specified, the display state is always supposed to be a front viewing state (i.e., when the screen is viewed perpendicularly by a viewer located right in front of the screen).

[0078] The quadruple pixel region **10** shown in FIG. **1** will be described. FIG. **1** illustrates a pixel region **10** provided for a substantially square pixel electrode for the sake of simplicity. However, the present invention is in no way limited to any particular shape of a pixel region.

[0079] The pixel region **10** includes four liquid crystal domains **A**, **B**, **C** and **D**, of which the tilt directions (i.e., reference alignment directions) are identified by **t1**, **t2**, **t3** and **t4**, respectively. These four tilt directions are defined such that an angle formed between any two of the four directions is approximately equal to an integral multiple of 90 degrees. This is an ideal quadruple structure to achieve the best viewing angle characteristic because the areas of these liquid crystal domains **A**, **B**, **C** and **D** are equal to each other. The four liquid crystal domains **A**, **B**, **C** and **D** are arranged in two columns and two rows to define a matrix pattern.

[0080] The pixel electrode has four edges (or sides) **SD1**, **SD2**, **SD3** and **SD4**. An oblique electric field to be generated responsive to a voltage applied produces an anchoring force that has a component that is perpendicular to any of these sides and that points toward the inside of the pixel electrode (in an azimuthal direction). In the example shown in FIG. **1**, the azimuthal directions that are perpendicular to the four edges **SD1**, **SD2**, **SD3** and **SD4** and that point toward the inside of the pixel electrode are identified by **e1**, **e2**, **e3** and **e4**, respectively.

[0081] Each of the four liquid crystal domains is close to two out of the four edges of the pixel electrode. While a voltage is being applied thereto, each liquid crystal domain is subjected to the anchoring forces that have been produced at those edges by the oblique electric field.

[0082] In an edge portion **EG1** of one edge of the pixel electrode, to which the liquid crystal domain **A** is located close, the azimuthal direction **e1** that is perpendicular to the edge portion **EG1** and that points toward the inside of the pixel electrode defines an angle greater than 90 degrees with respect to the tilt direction **t1** of the liquid crystal domain, and misalignment occurs in that area. As a result, when a voltage is applied thereto, the liquid crystal domain **A** produces an area that looks darker than the other areas (which will be referred to herein as a "domain line **DL1**") parallel to this edge portion **EG1**. It should be noted that in this case, the two polarizers are arranged so as to face each other with the liquid crystal layer interposed between them and to have their transmission axes (polarization axes) crossed at right angles. That is to say, one of the two polarization axes is arranged horizontally and the other vertically. The transmission axes of the polarizers are supposed to be arranged in this manner unless otherwise stated.

[0083] In the same way, in an edge portion **EG2** of one edge of the pixel electrode, to which the liquid crystal domain **B** is located close, the azimuthal direction **e2** that is perpendicular to the edge portion **EG2** and that points toward the inside of the pixel electrode defines an angle greater than 90 degrees with respect to the tilt direction **t2** of the liquid crystal domain, and misalignment occurs in that area. As a result, when a voltage is applied thereto, the liquid crystal domain **B** may produce an area that looks darker than the other areas (which will be referred to herein as a "domain line **DL2**") parallel to this edge portion **EG2**.

[0084] In the same way, in an edge portion **EG3** of one edge of the pixel electrode, to which the liquid crystal domain **C** is located close, the azimuthal direction **e3** that is perpendicular to the edge portion **EG3** and that points toward the inside of the pixel electrode defines an angle greater than 90 degrees with respect to the tilt direction **t3** of the liquid crystal domain, and misalignment occurs in that area. As a result, when a voltage is applied thereto, the liquid crystal domain **C** may produce an area that looks darker than the other areas (which will be referred to herein as a "domain line **DL3**") parallel to this edge portion **EG3**.

[0085] In the same way, in an edge portion **EG4** of one edge of the pixel electrode, to which the liquid crystal domain

D is located close, the azimuthal direction **e4** that is perpendicular to the edge portion **EG4** and that points toward the inside of the pixel electrode defines an angle greater than 90 degrees with respect to the tilt direction **t4** of the liquid crystal domain, and misalignment occurs in that area. As a result, when a voltage is applied thereto, the liquid crystal domain **D** may produce an area that looks darker than the other areas (which will be referred to herein as a "domain line **DL4**") parallel to this edge portion **EG4**.

[0086] If the horizontal direction on a display screen (i.e., the three o'clock direction) has an azimuthal angle of zero degrees, the tilt directions **t1**, **t2**, **t3** and **t4** are an approximately 225 degree direction (liquid crystal domain **A**), an approximately 315 degree direction (liquid crystal domain **B**), an approximately 45 degree direction (liquid crystal domain **C**) and an approximately 135 degree direction (liquid crystal domain **D**), respectively. The liquid crystal domains **A**, **B**, **C** and **D** are arranged such that the tilt directions of any two adjacent ones of the liquid crystal domains define an angle of approximately 90 degrees between them. The angle defined by any of the tilt directions **t1**, **t2**, **t3** and **t4** of the liquid crystal domains **A**, **B**, **C** and **D** with respect to an associated one of the azimuth angle components **e1**, **e2**, **e3** and **e4** of the anchoring forces produced by the oblique electric fields at the nearby edge portions **EG1**, **EG2**, **EG3** and **EG4** is approximately 135 degrees.

[0087] The dark areas (i.e., the domain lines **DL1** through **DL4**) that are produced parallel to the edge portions **EG1**, **EG2**, **EG3** and **EG4**, respectively, within the pixel region **10** deteriorate the viewing angle characteristic as will be described later. Thus, by providing opaque portions that can selectively shield at least respective parts of these edge portions **EG1** through **EG4** from incoming light, the deterioration of the viewing angle characteristic can be minimized.

[0088] As used herein, "to shield an edge portion from incoming light" means shielding not only the edge portion **EG1**, **EG2**, **EG3** or **EG4** but also its associated dark area (i.e., the domain line **DL1**, **DL2**, **DL3** or **DL4**) produced near the edge portion in the pixel region from incoming light. The location of each domain line (i.e., the distance from its associated edge portion of the pixel electrode) is changeable with the dimensions of the pixel electrode, for example. Typically, however, the opaque portion may be arranged so as to shield a range that reaches approximately 10 μm to 20 μm from any edge portion of the pixel electrode from incoming light. Also, "an opaque portion for selectively shielding an area from incoming light" means that the opaque portion is provided to shield only that area selectively from incoming light. Nevertheless, there is no need to isolate such an opaque portion for selectively shielding an area from incoming light from the other opaque portions. To minimize the deterioration in viewing angle characteristic, the opaque portions are preferably arranged so as to shield all of the domain lines from incoming light. However, the presence of the opaque portions would decrease the optical efficiency (represented by the effective aperture ratio of a pixel). If an opaque portion that shields at least a part of an edge portion (including a domain line produced around there) from incoming light is provided, then the deterioration in viewing angle characteristic can be lightened at least to that degree. That is why the portions to shield from incoming light may be determined so as to strike an adequate balance between the required performance of the LCD and the optical efficiency to achieve.

[0089] Typically, an opaque portion is arranged so as to shield an edge portion and a domain line, which is produced near the edge portion in the pixel region, from incoming light. However, if the pixel aperture ratio should be given a higher priority than the viewing angle characteristic to strike a proper balance between them, only a part or all of the domain line may be shielded from incoming light without shielding the edge portion in order to reduce the area of the opaque portion. In most of the preferred embodiments to be described below, the edge portion and all of the domain line are supposed to be shielded from incoming light. However, in any of those preferred embodiments, the viewing angle characteristic can be improved by providing an opaque portion that selectively shields at least a portion of the domain line.

[0090] A method of dividing a pixel region into these four liquid crystal domains **A** through **D** (i.e., the arrangement of the liquid crystal domains in the pixel region) is not limited to the example illustrated in FIG. 1. Alternative alignment division methods (or alternative arrangements of liquid crystal domains) will be described with reference to FIGS. 2 through 5.

[0091] Portion (a) of FIG. 2 shows a method of dividing the pixel region **10** shown in FIG. 1. More specifically, the pretilt directions **PA1** and **PA2** defined by the alignment film of a TFT substrate (i.e., the lower substrate), the pretilt directions **PB1** and **PB2** defined by the alignment film of a color filter (CF) substrate (i.e., the upper substrate), the tilt directions defined responsive to the application of a voltage to the liquid crystal layer, and areas that look dark due to misalignment (i.e., domain lines **DL1** through **DL4**) are shown in portion (a) of FIG. 2. Those areas are not so-called "disclination lines". These drawings schematically indicate the orientation directions of liquid crystal molecules as viewed by the viewer and show that the liquid crystal molecules are tilted such that the elliptical end of each cylindrical liquid crystal molecule points toward the viewer.

[0092] By conducting an alignment treatment so as to achieve the alignment state shown in portion (a) of FIG. 2, the pixel region **10** can be defined. Specifically, the alignment treatment is conducted so as to divide the pixel region close to the TFT substrate into two and to define the pretilt directions **PA1** and **PA2** that are antiparallel to the vertical alignment film. In this preferred embodiment, an optical alignment treatment is carried out by irradiating the liquid crystal layer with an ultraviolet ray obliquely that has come from the direction pointed by the arrows. The alignment treatment is also conducted so as to divide the pixel region close to the CF substrate into two and to define the pretilt directions **PB1** and

PB2 that are antiparallel to the vertical alignment film. By bonding these substrates together, a multi-domain structure can be defined in the pixel region **10**. In the optical alignment treatment, the light does not have to come from the directions indicated above. Alternatively, the pixel region on the CF substrate may be irradiated with a light ray that has come from a direction that is tilted with respect to the vertical direction (i.e., the column direction) and the pixel region on the TFT substrate may be irradiated with a light ray that has come from a direction that is tilted with respect to the horizontal direction (i.e., the row direction).

[0093] As already described with reference to FIG. 1, the domain lines **DL1**, **DL2**, **DL3** and **DL4** are produced in the liquid crystal domains **A**, **B**, **C** and **D** parallel to the edge portions **EG1**, **EG2**, **EG3** and **EG4**, respectively. The sum of the lengths of these four domain lines **DL1** through **DL4** will be an approximately half of the overall length of the four edges of the pixel electrode. The edge portions **EG1** and **EG3** (with the domain lines **DL1** and **DL3**) are parallel to the vertical direction, while the edge portions **EG2** and **EG4** (with the domain lines **DL2** and **DL4**) are parallel to the horizontal direction.

[0094] As shown in portion (a) of FIG. 2, a dark line is also observed in the boundary area of each of the liquid crystal domains **A** through **D**, which is adjacent to another one of the liquid crystal domains **A** through **D**, as indicated by the dashed line **CL1**. As will be described later, the crossed dark lines formed around the center of the pixel region are not always misalignment and do not have to be shielded on purpose. However, if an opaque member needs to be arranged within the pixel region, the opaque member is preferably arranged to hide these dark lines because the effective aperture ratio of the pixel (i.e., the optical efficiency) can be increased in that case.

[0095] Alternatively, by bonding together the TFT and CF substrates that have been subjected to the alignment treatment as shown in portion (b) of FIG. 2, a multi-domain structure can be defined for a pixel region **20**. This pixel region **20** also includes four liquid crystal domains **A**, **B**, **C** and **D**. The tilt directions of the liquid crystal domains **A** through **D** are the same as those of the liquid crystal domains of the pixel region **10** shown in FIG. 1.

[0096] The domain lines **DL1**, **DL2**, **DL3** and **DL4** are produced in the liquid crystal domains **A**, **B**, **C** and **D** parallel to the edge portions **EG1**, **EG2**, **EG3** and **EG4**, respectively. The sum of the lengths of these four domain lines **DL1** through **DL4** will be an approximately half of the overall length of the four edges of the pixel electrode. The edge portions **EG1** and **EG3** (with the domain lines **DL1** and **DL3**) are parallel to the horizontal direction, while the edge portions **EG2** and **EG4** (with the domain lines **DL2** and **DL4**) are parallel to the vertical direction. As shown in portion (b) of FIG. 2, a dark line is also observed in the boundary area of each of the liquid crystal domains **A** through **D**, which is adjacent to another one of the liquid crystal domains **A** through **D**, as indicated by the dashed line **CL1**. These dark lines are produced in the shape of a cross around the center of the pixel region.

[0097] Alternatively, by bonding together the TFT and CF substrates that have been subjected to the alignment treatment as shown in portion (a) of FIG. 3, a multi-domain structure can be defined for a pixel region **30**. This pixel region **30** also includes four liquid crystal domains **A**, **B**, **C** and **D**. The tilt directions of the liquid crystal domains **A** through **D** are the same as those of the liquid crystal domains of the pixel region **10** shown in FIG. 1.

[0098] The tilt directions **t1** and **t3** of the liquid crystal domains **A** and **C** do not point toward any edge portions of the pixel electrode, and therefore, no domain lines are produced in these liquid crystal domains. On the other hand, the tilt directions **t2** and **t4** of the liquid crystal domains **B** and **D** point toward their associated edge portions of the pixel electrode and define an angle greater than 90 degrees with respect to azimuthal directions that are perpendicular to the edge portions and that point toward the inside of the pixel electrode. As a result, domain lines **DL2** and **DL4** are produced. Each of the domain lines **DL2** and **DL4** includes a portion (**H**) that is parallel to the horizontal direction and a portion (**V**) that is parallel to the vertical direction. That is to say, each of the tilt directions **t2** and **t4** defines an angle greater than 90 degrees with respect to both an azimuthal direction that is perpendicular to an edge portion of the horizontal edge and that points toward the inside of the pixel electrode and an azimuthal direction that is perpendicular to an edge portion of the vertical edge and that points toward the inside of the pixel electrode. Consequently, domain lines are produced in both of the two directions. As shown in portion (a) of FIG. 3, a dark line is also observed in the boundary area of each of the liquid crystal domains **A** through **D**, which is adjacent to another one of the liquid crystal domains **A** through **D**, as indicated by the dashed line **CL1**. These dark lines are produced in the shape of a cross around the center of the pixel region.

[0099] Alternatively, by bonding together the TFT and CF substrates that have been subjected to the alignment treatment as shown in portion (b) of FIG. 3, a multi-domain structure can be defined for a pixel region **40**. This pixel region **40** also includes four liquid crystal domains **A**, **B**, **C** and **D**. The tilt directions of the liquid crystal domains **A** through **D** are the same as those of the liquid crystal domains of the pixel region **10** shown in FIG. 1.

[0100] The tilt directions **t1** and **t3** of the liquid crystal domains **A** and **C** point toward their associated edge portions of the pixel electrode and define an angle greater than 90 degrees with respect to azimuthal directions that are perpendicular to the edge portions and that point toward the inside of the pixel electrode. As a result, domain lines **DL1** and **DL3** are produced. Each of the domain lines **DL1** and **DL3** includes a portion **DL1(H)** or **DL3(H)** that is parallel to the horizontal direction and a portion **DL1(V)** or **DL3(V)** that is parallel to the vertical direction. That is to say, each of the tilt directions **t1** and **t3** defines an angle greater than 90 degrees with respect to both an azimuthal direction that is

perpendicular to an edge portion of the horizontal edge and that points toward the inside of the pixel electrode and an azimuthal direction that is perpendicular to an edge portion of the vertical edge and that points toward the inside of the pixel electrode. Consequently, domain lines are produced in both of the two directions. On the other hand, the tilt directions **t2** and **t4** of the liquid crystal domains **B** and **D** do not point toward any edge portions of the pixel electrode, and therefore, no domain lines are produced in these liquid crystal domains. As shown in portion (b) of FIG. 3, a dark line is also observed in the boundary area of each of the liquid crystal domains **A** through **D**, which is adjacent to another one of the liquid crystal domains **A** through **D**, as indicated by the dashed line **CL1**. These dark lines are produced in the shape of a cross around the center of the pixel region.

[0101] Alternatively, by bonding together the TFT and CF substrates that have been subjected to the alignment treatment as shown in portion (a) of FIG. 4, a multi-domain structure can be defined for a pixel region **50**. This pixel region **50** also includes four liquid crystal domains **A**, **B**, **C** and **D**. The tilt directions of the liquid crystal domains **A** through **D** are the same as those of the liquid crystal domains of the pixel region **10** shown in FIG. 1.

[0102] The tilt directions **t1**, **t2**, **t3** and **t4** of all of these liquid crystal domains **A**, **B**, **C** and **D** point toward their associated edge portions of the pixel electrode and define an angle greater than 90 degrees with respect to azimuthal directions that are perpendicular to the edge portions and that point toward the inside of the pixel electrode. As a result, domain lines **DL1**, **DL2**, **DL3** and **DL4** are produced. Each of the domain lines **DL1** through **DL4** includes a portion **DL1(H)**, **DL2(H)**, **DL3(H)** or **DL4(H)** that is parallel to the horizontal direction and a portion **DL1(V)**, **DL2(V)**, **DL3(V)** or **DL4(V)** that is parallel to the vertical direction. That is to say, each of the tilt directions **t1** through **t4** defines an angle greater than 90 degrees with respect to both an azimuthal direction that is perpendicular to an edge portion of the horizontal edge and that points toward the inside of the pixel electrode and an azimuthal direction that is perpendicular to an edge portion of the vertical edge and that points toward the inside of the pixel electrode. Consequently, domain lines are produced in both of the two directions. As shown in portion (a) of FIG. 4, a dark line is also observed in the boundary area of each of the liquid crystal domains **A** through **D**, which is adjacent to another one of the liquid crystal domains **A** through **D**, as indicated by the dashed line **CL1**. These dark lines are produced in the shape of a cross around the center of the pixel region.

[0103] Alternatively, by bonding together the TFT and CF substrates that have been subjected to the alignment treatment as shown in portion (b) of FIG. 4, a multi-domain structure can be defined for a pixel region **60**. This pixel region **60** also includes four liquid crystal domains **A**, **B**, **C** and **D**. The tilt directions of the liquid crystal domains **A** through **D** are the same as those of the liquid crystal domains of the pixel region **10** shown in FIG. 1.

[0104] None of the tilt directions **t1**, **t2**, **t3** and **t4** of the liquid crystal domains **A** through **D** point toward any edge portions of the pixel electrode, and therefore, no domain lines are produced at all in these liquid crystal domains. A dark line is also observed in the boundary area of each of the liquid crystal domains **A** through **D**, which is adjacent to another one of the liquid crystal domains **A** through **D**, as indicated by the dashed line **CL1**. These dark lines are produced in the shape of a cross around the center of the pixel region.

[0105] In each of the four-domain structures described above, four liquid crystal domains are arranged in two columns and two rows to define a matrix pattern. However, the present invention is in no way limited to that specific preferred embodiment. Alternatively, the four liquid crystal domains may be arranged in line in a predetermined direction as shown in FIGS. 5(a) and 5(b), in which the liquid crystal domains are arranged in line in the column direction.

[0106] The pixel region **70** shown in FIG. 5(a) also includes four liquid crystal domains **A**, **B**, **C** and **D**. The tilt directions of the liquid crystal domains **A** through **D** are the same as those of the liquid crystal domains of the pixel region **10** shown in FIG. 1. The tilt directions **t1**, **t2**, **t3** and **t4** of all of these liquid crystal domains **A**, **B**, **C** and **D** point toward their associated edge portions of the pixel electrode and define an angle greater than 90 degrees with respect to azimuthal directions that are perpendicular to the edge portions and that point toward the inside of the pixel electrode. As a result, domain lines **DL1**, **DL2**, **DL3** and **DL4** are produced. All of these domain lines **DL1** through **DL4** are parallel to the vertical direction (i.e., the direction in which the liquid crystal domains are arranged). A dark line is also observed in the boundary area of each of the liquid crystal domains **A** through **D**, which is adjacent to another one of the liquid crystal domains **A** through **D**. These dark lines are produced horizontally (i.e., perpendicularly to the direction in which the liquid crystal domains are arranged) around the center of the pixel region.

[0107] On the other hand, in the pixel region **80** shown in FIG. 5(b), the tilt directions of the four liquid crystal domains **A'**, **B'**, **C'** and **D'** are 90 degrees, 180 degrees, 0 degrees and 270 degrees, respectively, as shown in that drawing. The domain lines **DL1'** and **DL4'** of the liquid crystal domains **A'** and **D'** are parallel to the horizontal direction. And the domain lines **DL2'** and **DL3'** are parallel to the vertical direction. A dark line is also observed in the boundary area of each of the liquid crystal domains **A'** through **D'**, which is adjacent to another one of the liquid crystal domains **A'** through **D'**. These dark lines are produced horizontally (i.e., perpendicularly to the direction in which the liquid crystal domains are arranged) around the center of the pixel region. If the tilt directions are defined in this manner, the polarizers are preferably arranged such that their transmission axes define angles of ± 45 degrees with respect to the horizontal direction.

[0108] Next, it will be described with reference to FIGS. 6 through 9 how domain lines are produced near the edge

portions of a pixel electrode and how dark lines are produced (in the shape of a cross as shown in FIG. 2, for example) around the center of the pixel region. FIGS. 6 through 9 are cross-sectional views of a pixel region of a liquid crystal display device, showing the equipotential curve of an electric field created in the liquid crystal layer 3, the orientation directions of liquid crystal molecules 3a in the layer, and the relative (front) transmittance thereof, which were figured out by simulations.

[0109] This liquid crystal display device includes a TFT substrate 1 including a transparent substrate (e.g., a glass substrate) 1a and a pixel electrode 11 on the transparent substrate 1a, a CF substrate 2 including a transparent substrate (e.g., a glass substrate) 2a and a counter electrode 12 on the transparent substrate 2a, and a vertical alignment liquid crystal layer 3 interposed between the TFT and CF substrates 1 and 2. A vertical alignment film (not shown) is provided on each of the TFT and CF substrates 1 and 2 so as to contact with the liquid crystal layer 3. The liquid crystal layer is subjected to an alignment treatment so as to have the pretilt directions controlled as indicated by the arrows, arrowheads and arrow tails in FIGS. 6 to 9.

[0110] First, referring to FIG. 6, illustrated is a cross-sectional view of the left half of the pixel region 20 shown in portion (b) of FIG. 2, including an edge portion of the liquid crystal domain D with the domain line DL4, as viewed on a plane defined by an azimuth angle of zero degrees. It can be seen that at an edge portion of the pixel electrode 11 shown in FIG. 6, liquid crystal molecules 3a (with a tilt angle of 135 degrees), located around the center of a plane of the liquid crystal domain and approximately at the middle of the thickness thereof, are gradually twisted toward the edge portion of the pixel electrode under the anchoring force (defined by an azimuthal direction of zero degrees) of an oblique electric field generated in the edge portion of the pixel electrode 11. In this example, the twist angle is 135 degrees, which is greater than 90 degrees. That is why due to a variation in retardation in this twisting region of the liquid crystal layer, the relative transmittance varies in a complicated manner as shown in FIG. 6, thereby producing a domain line in which the relative transmittance becomes local minimum within the pixel region (i.e., inside of the edge of the pixel electrode). That region with the local minimum transmittance as indicated by the dotted square in FIG. 6 corresponds to the domain line DL4 in the liquid crystal domain D shown in portion (b) of FIG. 2.

[0111] On the other hand, in another edge portion of the pixel electrode in which no domain line is produced as shown in FIG. 7, the twist angle of the liquid crystal molecules (i.e., the difference in tilt direction between the liquid crystal molecules located around the center of the liquid crystal domain and the liquid crystal molecules, of which the alignment is controlled by an oblique electric field that has been generated in the edge portion of the pixel electrode 11) is 90 degrees or less. And the relative transmittance decreases monotonically from the central portion of the pixel region toward the end thereof and reaches its local minimum outside of the pixel region (i.e., at the left end of FIG. 7), not inside of the pixel region. FIG. 7 is a cross-sectional view of the lower half of the pixel region 20 shown in portion (b) of FIG. 2, including another edge portion of the liquid crystal domain D without the domain line DL4, as viewed on a plane defined by an azimuth angle of 90 degrees.

[0112] Meanwhile, as shown in FIGS. 8 and 9, the liquid crystal molecules also have a twist angle of 90 degrees or less in the boundary area in which two liquid crystal domains are adjacent to each other within the pixel region. Thus, the relative transmittance also changes simply and reaches a local minimum value there. FIG. 8 is a cross-sectional view of the liquid crystal domains D and A shown in portion (b) of FIG. 2, including the boundary area between them, as viewed on a plane defined by an azimuth angle of zero degrees. FIG. 9 is a cross-sectional view of the liquid crystal domains B and A shown in portion (b) of FIG. 4, including the boundary area between them, as viewed on a plane defined by an azimuth angle of zero degrees.

[0113] FIG. 10 shows the distributions of transmission intensities in a situation where the pixel region 10 is viewed from the direction defined by an azimuth angle of 45 degrees. The four graphs of FIG. 10 show the distributions of transmission intensities on the four planes I, II, III and IV, respectively. Also, each of these graphs shows results in three viewing directions defined by polar angles of zero degrees (i.e., front direction), 45 degrees and 60 degrees, respectively.

[0114] It can be seen that in the domain lines appearing at the left end of Graph I, at the right end of Graph II, at the right end of Graph III, and at the left end of Graph IV, the behavior of the transmission intensity changes significantly according to the polar angle (particularly in Graph III). That is to say, the location with the minimum transmission intensity changes with the polar angle. For example, the transmission intensity in the front viewing direction (defined by a polar angle of zero degrees) is local minimum, whereas the transmission intensities at the polar angles of 45 and 60 degrees are local maximum. If the transmission intensity changes according to the polar angle in this manner, the viewing angle characteristic deteriorates. Among other things, the viewing angle dependence of γ characteristic deteriorates significantly to cause a phenomenon called "whitening".

[0115] By providing opaque portions that can selectively shield at least respective portions of the domain lines, produced in the edge portions of the pixel electrode, from incoming light, such deterioration in viewing angle characteristic can be reduced. Also, those domain lines are produced in the edge portions when the tilt directions of the liquid crystal molecules around the center of the liquid crystal layer are defined as described above with respect to the edges of the electrode. That is why the domain lines may also be produced in a normal pixel region with no multi-domain structures. For that reason, to minimize the deterioration in viewing angle characteristic due to the production of domain lines in the edge

portions of the pixel electrode, such opaque portions for selectively shielding at least respective portions of the domain lines are preferably provided, no matter whether the multi-domain structure should be formed or not.

[0116] The dark lines formed around the center of the pixel region (e.g., crossed lines CL1) are not always misalignment and do not have to be shielded on purpose. However, if an opaque member needs to be arranged within the pixel region, the opaque member is preferably arranged to hide these dark lines because the effective aperture ratio of the pixel (i.e., the optical efficiency) can be increased in that case.

[0117] Hereinafter, preferred embodiments of opaque portions will be described specifically. Each of the opaque portions to be described below may be used either by itself or in combination with any other opaque portion.

[0118] A TFT LCD usually includes an opaque member. For example, a TFT substrate includes a gate bus line, a source bus line, a drain extension line and a storage capacitor line (which will be referred to herein as a "CS bus line"). Also, a CF substrate includes a black matrix to shield the surrounding areas of color filters that are arranged so as to overlap with pixel regions. The opaque portions for selectively shielding at least portions of the domain lines may be defined by using these opaque members. Furthermore, to minimize the decrease in optical efficiency caused by the opaque member arranged within the pixel region, the opaque member is preferably arranged so as to hide the dark area produced between adjacent liquid crystal domains.

[0119] Hereinafter, an exemplary pixel structure for a liquid crystal display device according to the present invention will be described. In the drawings, any pair of components shown in multiple drawings and having substantially the same function is identified by the same reference numeral. And once a component has been described, the description of its counterpart will be omitted herein to avoid redundancies. Also, in a number of pixels that are arranged in columns and rows so as to form a matrix pattern, the structure of a pixel located at an intersection between an m^{th} row and an n^{th} column will be described. It should be noted that a row corresponds to an arrangement of pixels along a gate bus line (or scan line), while a column corresponds to an arrangement of pixels along a source bus line (or signal line). Typically, rows are defined in the horizontal direction on the display screen, while columns in the vertical direction on the display screen.

[0120] The opaque portions may be defined by using at least portions of the source bus line **114**, the CS bus line **113**, the drain extension line **117** and the gate bus line **112** as shown in FIG. **11**, for example. In the following description, an m^{th} gate bus line **112** will be referred to herein as a "gate bus line **112 (m)**" and an n^{th} source bus line **114** will be referred to herein as a "gate bus line **114(n)**".

[0121] The pixel region shown in FIG. **11** illustrates a subpixel with the multipixel structure disclosed in Japanese Patent Application Laid-Open Publication No. 2004-62146. The following description will be focused on the structure of the upper one of the two subpixel regions that has the subpixel electrode **111a**.

[0122] The sub-pixel electrode **111a** is connected to the drain electrode **116D** of the TFT **116** and is arranged so as to partially overlap with the source bus line **114**, the gate bus line **112** and the CS bus line **113** with an interlayer dielectric film (not shown) of resin interposed between them. Also, at the center of the sub-pixel electrode **111a**, a storage capacitor **CS** is formed by an extended portion **117E** of the drain extension line **117**, an extended portion **113E** of the CS bus line **113** and an insulating layer (e.g., a gate insulating layer) between them.

[0123] The multipixel structure shown in FIG. **11** has the following features.

[0124] The conventional pixel electrode is divided into two subpixel electrodes, which are connected to the same source bus line **114** by way of their associated TFTs **116a** and **116b** (i.e., two TFTs in total). The ON and OFF states of the two TFTs **116a** and **116b** are controlled through the common gate bus line **112**. The two TFTs **116a** and **116b** share a semiconductor layer **116m**, a source electrode **116S**, and a gate electrode (gate bus line **112**) in common. And the respective drain electrodes **116D** of the two TFTs are electrically connected to their associated subpixel electrodes. The drain electrode **116D** of the TFT **116a** and the subpixel electrode **111a** are electrically connected together by connecting the drain extension line **117**, extending from the drain electrode **116D**, to the subpixel electrode **111a** in a contact hole **119** that has been cut through an interlayer dielectric film (which is not shown in FIG. **11** but is identified by the reference numeral **118a** in FIG. **15**).

[0125] Each subpixel electrode (which is the upper subpixel electrode **111a** with the lower subpixel electrode not shown there), the liquid crystal layer, and a counter electrode (common electrode) that faces these electrodes with the liquid crystal layer interposed between them form a liquid crystal capacitor. Storage capacitors CS are formed electrically in parallel with the liquid crystal capacitors associated with the respective subpixel regions. As for the upper subpixel, one of the two electrodes that form the storage capacitor (i.e., the storage capacitor electrode) is defined by the extended portion **117E** of the drain extension line **117** that is connected to the drain **116D** of the same TFT **116a** as the subpixel electrode **111a**, while the other electrode (i.e., the storage capacitor counter electrode) is defined by the extended portion **113E** of the CS bus line **113** provided for the upper subpixel. Likewise, as for the lower subpixel, one of the two electrodes that form the storage capacitor (i.e., the storage capacitor electrode) is defined by the extended portion (not shown) of the drain extension line (not shown) that is connected to the drain (not shown) of the same TFT **116b** as the lower subpixel electrode (not shown), while the other electrode (i.e., the storage capacitor counter electrode) is defined by the extended portion (not shown) of the CS bus line (not shown) provided for the lower subpixel.

[0126] The CS bus lines **113** are provided electrically independently of each other for the two subpixels. For example, if the storage capacitor counter voltage supplied to the storage capacitor belonging to one subpixel through the CS bus line **113** rises after the TFT **116a** has been turned OFF, the storage capacitor counter voltage supplied to the storage capacitor belonging to the other subpixel through the CS bus line **113** falls after the TFT **116b** has been turned OFF. If (the magnitudes and/or the directions of) the storage capacitor counter voltages of the storage capacitors belonging to the respective subpixels are changed differently after their associated TFTs have been turned OFF, different effective voltages will be applied to the respective liquid crystal layers of the two subpixels. As a result, the two subpixels can present two different luminances (one of which is relatively high and the other of which is relatively low) with respect to the display signal voltage supplied through the source bus line **114**. Consequently, the viewing angle dependence of the γ characteristic can be reduced.

[0127] The sub-pixel region shown in FIG. 11 has a multi-domain structure similar to that of the pixel region **10** described above. That is to say, domain lines are produced near the edge portions **EG1**, **EG2**, **EG3** and **EG4** of the sub-pixel electrode and crossed dark lines are produced at the center of the sub-pixel region.

[0128] The opaque portions for selectively shielding at least portions of the domain lines produced near the edge portions **EG1** and **EG3** may be formed by bending the source bus line **114** in a direction that crosses its length direction (the vertical direction), i.e., toward the sub-pixel electrode. Optionally, the opaque portions may also be formed by locally increasing the width of the source bus line **114**. However, the opaque portions are preferably formed by bending the source bus line because the stray capacitance might increase if the source bus line had an increased width.

[0129] The domain line produced in the edge portion **EG2** may be shielded by increasing the width of overlap between the edge portion of the sub-pixel electrode **111a** and the gate bus line **112**. The overlap width may be increased either by partially increasing the width of the sub-pixel electrode **111a** or the gate bus line **112** (e.g., by providing the broadened portion **111E** of the subpixel electrode **111a** shown in FIG. 11) or by bending the gate bus line **112** in a direction that crosses its length direction (i.e., the horizontal direction).

[0130] The domain line produced in the edge portion **EG4** may be shielded by increasing the width of overlap between the edge portion of the sub-pixel electrode **111a** and the CS bus line **113**. The overlap width may be increased either by partially increasing the width of the sub-pixel electrode **111a** or the CS bus line **113** (e.g., by providing the broadened portion **113A** of the CS bus line **113** shown in FIG. 11) or by bending the CS bus line **113** in a direction that crosses its length direction (i.e., the horizontal direction).

[0131] The opaque portions for selectively shielding at least portions of the dark areas produced in the boundary areas between the liquid crystal domains may be formed by respective extended portions **113e** and **113E** of the CS bus line **113** and the drain extension line **117** and its extended portion **117E**. By using the storage capacitor CS in the pixel as an opaque portion in this manner, the extra decrease in optical efficiency can be minimized.

[0132] Alternatively, the CS bus line **113** may have not only the extended portions **113e** and **113E** for shielding the crossed dark lines at the center of the pixel region but also additional extended portions **113E1** and **113E2** for shielding the domain lines produced in the edge portions **EG1** and **EG2**, respectively, as shown in FIG. 12.

[0133] If a multi-domain structure similar to that of the pixel region **30** shown in portion (a) of FIG. 3 is formed for the sub-pixel region, then the arrangement shown in FIG. 13 may be adopted, for example.

[0134] Specifically, the domain line (**DL4(H)**) shown in portion (a) of FIG. 3) produced in the horizontal part of the edge portion **EG4** may be shielded by increasing the width of overlap between the CS bus line **113** and the sub-pixel electrode **111a**. The width of overlap can be increased by partially increasing the width of the sub-pixel electrode **111a** such that an extended portion **111E1** is formed. On the other hand, the domain line (**DL2(H)**) shown in portion (a) of FIG. 3) produced in the horizontal part of the edge portion **EG2** may be shielded by increasing the width of overlap between the gate bus line **112** and the sub-pixel electrode **111a**. The width of overlap can be increased by partially increasing the width of the sub-pixel electrode **111a** such that an extended portion **111E2** is formed. The vertical parts of the edge portions **EG2** and **EG4** (**DL2(V)** and **DL4(V)**) shown in portion (a) of FIG. 3) may be shielded by the bent portions of the source bus line **114** as in the example described above.

[0135] If a multi-domain structure similar to that of the pixel region **10** is adopted, the opaque portions for shielding the dark areas produced in the boundary areas between the liquid crystal domains may be defined by the extended portions **117E** and **117E'** of the drain extension line **117** as shown in FIG. 14. The extended portion **117E** faces the CS bus line **113** to form a storage capacitor.

[0136] FIG. 15 is a cross-sectional view of the structure shown in FIG. 14 as viewed on the plane **15A-15A'** shown in FIG. 14. As shown in FIG. 15, the drain extension line **117** and the gate bus line **112** interpose a gate insulating film **115** between them. Thus, leakage is less likely to be produced between the drain extension line **117** and the gate bus line **112** because these belong to two separate layers. A normal pixel with no multipixel structure is illustrated in FIG. 14. When this arrangement is applied to a multipixel structure, even if a CS bus line is arranged in place of the gate bus line **112** in the upper part of FIG. 14, the opaque portion may also be formed to hide the central cross lines by the extended portions **117E** and **117E'** of the drain extension line **117** as shown in FIG. 14, too. The CS bus line **113** is made of the same conductive layer (which is typically a metal layer) as the gate bus line **112**. That is why leakage is

less likely to be produced between the drain extension line **117** and the CS bus line **113**. That is to say, the vertical part of the opaque portion to form the cross and the horizontal part of the opaque portion to shield the horizontal edge portion are preferably made of two different layers. By adopting such an arrangement, the leakage failures can be reduced compared to the configuration disclosed in FIG. **60** of Patent Document No. 1.

[0137] In the pixel structure shown in FIG. **15**, a relatively thick interlayer dielectric film **118a** of a photosensitive resin, for example, is interposed between the pixel electrode **111** and the source bus line **114**. That is why even if the pixel electrode **111** (or the subpixel electrode **111a**) and the source bus line **114** (and the gate bus line **112**) are stacked one upon the other as shown in FIG. **14**, the capacitance produced between the pixel electrode **111** and the source bus line **114** can be reduced sufficiently. Consequently, the voltage at the pixel electrode **111** never varies due to the voltage (i.e., signal voltage) on the source bus line **114** by way of the capacitance. That is to say, by adopting the pixel structure shown in FIG. **15** in which the pixel electrode **111** and the source bus line **114** are stacked one upon the other, the aperture ratio of the pixel can be increased.

[0138] Alternatively, the domain lines produced in the edge portions and the crossed dark lines produced around the center of the pixel region may be shielded by the extended portion **113e** of the CS bus line **113** as shown in FIGS. **16** and **17**. In the arrangement illustrated in FIGS. **16** and **17**, a relatively thin interlayer dielectric film **118b** of an inorganic material such as SiN_x , for example, is provided between the pixel electrode **111** and the source bus line **114**. In this arrangement, to prevent the voltage at the pixel electrode **111** from being affected by the voltage (i.e., signal voltage) on the source bus line **114**, the pixel electrode **111** and the bus lines are arranged so as not to overlap each other. This arrangement does not contribute to increasing the aperture ratio of a pixel but can simply the manufacturing process because a relatively thin inorganic insulating film can be used as the interlayer dielectric film **118b**.

[0139] As another alternative, the domain lines produced in the edge portions and the crossed dark lines produced around the center of the pixel region may also be shielded by extending the drain extension line **117** as shown in FIG. **18**. Since the drain extension line **117** belongs to a different layer from that of the gate bus line **112** and the CS bus line **113** as described above, leakage failures are less likely to occur between them. A sub-pixel region with a multipixel structure is illustrated in FIG. **18**. However, this structure is equally applicable for use in a normal pixel region, too.

[0140] In each of the examples described above, the opaque portions are defined by using the opaque members arranged on the TFT substrate. If necessary, however, part or all of the opaque portions may be located on the CF substrate. For example, opaque portions with relatively broad widths (e.g., the opaque portions for shielding the domain lines produced in the edge portions parallel to the vertical direction and the opaque portion for shielding the crossed dark lines produced around the center of the pixel region) may be defined by the black matrix layer **132** on the CF substrate as shown in FIG. **19**. In this example, the horizontally extending portion of the crossed dark lines around the center of the pixel is supposed to be shielded entirely by the extended portion **132E** of the black matrix layer **132**. Alternatively, part of that portion may be shielded by the black matrix layer **132** and the other part may be shielded by the drain extension line **117**. Still alternatively, any of the shielding structures and this arrangement may be combined appropriately.

[0141] Also, in the LCD manufacturing process of the preferred embodiment described above, at least the substrate with the opaque portions is preferably irradiated with light (typically an ultraviolet ray) for the purpose of optical alignment treatment. The opaque portions described above are provided in areas where misalignment may arise in the multi-domain structure. That is why if the opaque portions were provided for the other substrate to face the substrate that has been irradiated with light to define the multi-domain structure, then an alignment error should be considered when those substrates are bonded together and the size of the opaque portions should be increased excessively, which is not beneficial. Also, the substrate is preferably irradiated with light that has come from a direction in which the light is not affected by the unevenness on the surface of the substrate. For example, if the CF substrate is irradiated with light, the light preferably comes from the column direction. Then, no shadow areas would be produced by the black matrix that is arranged between the rows.

Intersection

[0142] The present inventors discovered that at the intersections **OD** between the domain lines produced in the edge portions and the boundary areas between adjacent liquid crystal domains, the liquid crystal molecules had particularly inconsistent orientations and noticeably low response speeds as shown in FIG. **20**. For that reason, in an application that pays much attention to moving picture display performance, those areas surrounding the intersections **OD** where the liquid crystal molecules have inconsistent orientations are preferably shielded.

[0143] Those intersections **OD** are preferably shielded by providing extensions **TR1**, **TR2**, **TR3** and **TR4** that protrude out of the opaque portions for shielding the domain lines produced in the edge portions and the opaque portions for shielding the boundary area between adjacent liquid crystal domains as shown in FIG. **21**. Specifically, the extensions **TR1** and **TR3** are extended from the CS bus line extended portion **113E**, the extension **TR2** is extended from the gate bus line **112**, and the extension **TR4** is extended from the CS bus line **113**. If necessary, it is naturally possible to shield

only the intersections **OD** selectively. The extensions **TR1** through **TR4** shown in FIG. **22** have an almost triangular shape. However, the extensions may have any other shape as long as the optical efficiency (or aperture ratio) does not decrease unnecessarily. In view of this consideration, the extensions preferably have such a triangular shape as shown in FIG. **21**.

5

Partial shielding

[0144] The liquid crystal display device of the preferred embodiment described above includes opaque portions for shielding edge portions with domain lines substantially entirely. However, the present invention is in no way limited to that specific preferred embodiment. To minimize the deterioration in viewing angle characteristic, the opaque portions are preferably arranged so as to shield the domain lines from incoming light entirely as described above. If the opaque portions were present, however, the optical efficiency (i.e., the effective aperture ratio of a pixel) would decrease. That is why the edge portions may be shielded partially to strike an adequate balance between the viewing angle characteristic and the optical efficiency.

10

[0145] Particularly if an arrangement in which the pixel electrode does not overlap with the source bus line as viewed perpendicularly to the substrate (see the cross-sectional view shown in FIG. **17**, for example) is adopted, the pixel aperture ratio decreases. For that reason, to avoid a significant decrease in pixel aperture ratio, the opaque areas are preferably as small as possible. If a relatively thick interlayer dielectric film **118a** of a photosensitive resin, for example, is interposed between the pixel electrode **111** and the source bus line **114** as shown in FIG. **15**, the capacitance produced between the pixel electrode **111** (or the subpixel electrode **111a**) and the source bus line **114** (and the gate bus line **112**) can be reduced sufficiently even when the pixel electrode **111** (or the subpixel electrode **111a**) overlaps with the source bus line **114** (and the gate bus line **112**) as shown in FIGS. **14**, **18**, **19** and **21**. That is why the voltage at the pixel electrode **111** (or the subpixel electrode **111a**) is not affected by the voltage (i.e., signal voltage) on the source bus line **114** by way of this capacitance. Consequently, by overlapping the pixel electrode **111** (or the subpixel electrode **111a**) and the source bus line **114** (and the gate bus line **112**) each other, the pixel aperture ratio can be increased.

15

20

25

[0146] On the other hand, if an arrangement in which the pixel electrode **111** does not overlap with the source bus line **114** (and the gate bus line **112**) is adopted as shown in the cross-sectional view of FIG. **17**, then a relatively thin inorganic insulating film of SiN_x , for example, may be used as the interlayer dielectric film **118b**. As a result, the manufacturing process can be simplified, which is advantageous. However, if such an arrangement in which the pixel electrode **111** does not overlap with the source bus line **114** is adopted, the pixel aperture ratio will decrease. For that reason, to achieve a sufficient display luminance, the opaque portions are preferably as small as possible.

30

Adjustment of DC voltage level between subpixels

[0147] Hereinafter, a preferred embodiment for adjusting a DC voltage level between subpixels will be described with reference to FIGS. **22** through **29**. The preferred embodiment to be described below is a liquid crystal display device, of which each subpixel region has the four-domain structure shown in FIG. **1**. However, the present invention is in no way limited to that specific preferred embodiment. Rather, the present invention is broadly applicable to any liquid crystal display device that has a structure for shielding a domain line (i.e., a dark area), which is produced in the vicinity (inside) of, and substantially parallel to, an edge portion of a subpixel electrode when the edge portion is overlapped with a gate bus line. For example, the present invention is also applicable to the structure of the subpixel region shown in FIGS. **11** to **14**.

35

40

[0148] First of all, it will be described why it is necessary to adjust the DC voltage level between subpixels.

[0149] In a TFT liquid crystal display device, the parasitic capacitance of a TFT and the operation of switching the TFT from ON state into OFF state produce a feedthrough phenomenon on a voltage at a pixel electrode. To compensate for this feedthrough voltage, an offset voltage corresponding to the feedthrough voltage is applied to a counter electrode that is arranged so as to face the pixel electrode with a liquid crystal layer interposed between them. If this feedthrough voltage and the offset voltage do not agree with each other (and their difference is sometimes called a "a deviation of a counter electrode voltage"), then the effective voltage applied to the liquid crystal layer changes every time the polarity of the voltage applied to the liquid crystal layer is inverted. As a result, the difference is recognized as a flicker.

45

50

[0150] In the multi-domain structure of the pixel shown in FIG. **22**, each of the upper and lower subpixel regions has the four liquid crystal domains shown in FIG. **1** just like the multi-domain structure shown in FIG. **11**. Thus, in each subpixel region, produced are not only domain lines in the vicinity of the edge portions **EG1** to **EG4** (see FIG. **1**) of the subpixel electrode but also crossed dark lines at the center of the subpixel region.

55

[0151] The opaque portions for selectively shielding the domain lines produced near the edge portions **EG1** and **EG3** (see FIG. **1**) may be formed by bending the source bus lines **114** in a direction that crosses their length direction (the vertical direction), i.e., toward the sub-pixel electrode. Optionally, the opaque portions may also be formed by locally increasing the width of the source bus lines **114**. However, the opaque portions are preferably formed by bending the

source bus lines because the stray capacitance might increase if the source bus lines had an increased width. Alternatively, those portions could also be shielded by a black matrix (BM) **132** provided for the counter substrate (which is typically a color filter substrate). The BM **132** is partially expanded to shield the semiconductor layer **116m** of the TFTs **116a1** and **116a2**.

[0152] The domain line produced in the edge portion **EG2** (see FIG. 1) may be shielded by increasing the width of overlap between the edge portions of the sub-pixel electrodes **111a1** and **111a2** and the gate bus line **112**. The overlap width may be increased by partially increasing the width of the gate bus line **112**. The domain line produced in the edge portion **EG4** (see FIG. 1) may be shielded by increasing the width of overlap between the edge portions of the sub-pixel electrodes **111a1** and **111a2** and the storage capacitor line **113**. The overlap width may be increased by partially increasing the width of the storage capacitor line (CS bus line) **113**.

[0153] The opaque portions for selectively shielding the dark areas produced in the boundary areas between the liquid crystal domains may be formed by respective extended portions of the CS bus line and the drain extension line. By using the storage capacitor CS in the pixel as an opaque portion in this manner, the decrease in optical efficiency can be minimized.

[0154] However, in a liquid crystal display device having a structure in which the subpixel electrodes **111a** overlap with the gate bus line **112** as in the multi-domain pixel structure shown in FIG. 22, the magnitude of the feedthrough voltage may change from one subpixel region to another. That is to say, as can be seen from FIG. 22, if the area of the overlapping portion between the subpixel electrode **111a1** (associated with the upper subpixel region) and the gate bus line does not agree with that of the overlapping portion between the subpixel electrode **111a2** (associated with the lower subpixel region) and the same gate bus line **112**, then the respective subpixel regions have feedthrough voltages of mutually different magnitudes. And if the magnitudes of feedthrough voltages are different between the subpixel regions, then the magnitudes of the best offset voltages are also different between the subpixel regions. As a result, the deviation of the counter electrode voltage is produced in at least one of the two subpixel regions. It should be noted that the counter electrode (not shown) that faces the subpixel electrodes **111a1** and **111a2** with the liquid crystal layer interposed between them is typically a common single electrode that covers the entire display area. A big liquid crystal display device may be provided with two or more counter electrodes. In any case, however, every subpixel electrode included in the same pixel region faces the same counter electrode.

[0155] FIG. 23(a) is a schematic cross-sectional view as viewed on the plane X-X' shown in FIG. 22 and FIG. 23(b) is a schematic cross-sectional view as viewed on the plane Y-Y' shown in FIG. 22. In FIGS. 23(a) and 23(b), the hatched portions **CGD1**, **CGD2** and **CGD2** schematically indicate portions that produce the gate-drain capacitance **Cgd**. As shown in FIG. 23(a), in this TFT, the gate electrode (i.e., a portion projecting from the gate bus line) **116G1** and the drain electrode **116D1** have portions that face each other with a gate insulating film **115**, a semiconductor layer **116m** (i.e., i-layer) and another semiconductor layer (n+ layer) functioning as a part of the drain electrode **116D1** interposed between them. Also, as shown in FIG. 23(b), the gate bus line **112** and the subpixel electrodes **111a1** and **111a2** have portions **CGD2** and **CGD3** that face each other with the gate insulating film **115**, a passivation film **118a** and an interlayer dielectric film **118b** interposed between them. These portions **CGD2** and **CGD3** produce **Cgd**. However, capacitance is actually produced where an electric field is generated, and therefore, in a broader range than the illustrated one (i.e., the projected ranges defined by a normal to the surface of the substrate).

[0156] FIG. 24 shows an equivalent circuit of a pixel having the multi-domain pixel structure shown in FIG. 22, in which the subscript "1" attached to a component indicates that the component is associated with the upper subpixel region and the subscript "2" attached to a component indicates that the component is associated with the lower subpixel region. The LC capacitor means a liquid crystal capacitor formed by the subpixel electrode, the counter electrode and the liquid crystal layer between them. The CS capacitor means a storage capacitor formed by the respective extended portions of the drain extension line and the storage capacitor line and the insulating layer between them (i.e., the gate insulating layer in this case). **CgdI** denotes a capacitance component formed by the overlapping portion between the drain and gate electrodes (i.e., the component shown in FIG. 23(a)). And **CgdII** denotes capacitance components formed by the overlapping portions between the subpixel and gate electrodes (i.e., the components shown in FIG. 23(b)). To prevent the deviation of the counter electrode voltage from being produced between the opposing electrodes as described above, $CgdI + CgdII (=Cgd$ in this case) should be equal to each other in the two subpixel regions.

[0157] FIG. 25 is an enlarged view of a portion of the multi-domain pixel structure shown in FIG. 22 where **Cgd** is produced. As shown in FIG. 25, the capacitance(s) of **CgdI1** and/or **CgdII1** that form **Cgd1** of the upper subpixel region may be adjusted and equalized with **Cgd2** ($=CgdI2 + CgdII2$) of the lower subpixel region.

[0158] Suppose **CgdI** is a capacitance component corresponding to the hatched portion shown in FIG. 23(a) and **CgdII** is capacitance components corresponding to the hatched portions shown in FIG. 23(b). In that case, **CgdI1** is proportional to the area of overlap **SA** (which is affected by an oblique electric field and is greater than the area of overlap projected along a normal) between the drain electrode **116D1** and the gate electrode **116G1** and **CgdII1** is proportional to the area of overlap **SB** between the gate bus line **112** and the subpixel electrode **111a1** as shown in FIG. 25. Their proportionality constants depend on the thickness and relative dielectric constant of the dielectric layer (such as the gate insulating

film) between two electrodes that form a capacitor. In the same way, CgdI2 is proportional to the area of overlap **SC** between the drain electrode **116D2** and the gate electrode **116G2** and CgdII2 is proportional to the area of overlap **SD** between the gate bus line **112** and the subpixel electrode **111a2**.

[0159] As can be seen from FIG. 25, the area of overlap (as indicated by the hatching) between the lower subpixel electrode **111a2** and the gate bus line **112** is greater than the area of overlap between the upper subpixel electrode **111a1** and the gate bus line **112**. This is because the lower subpixel electrode **111a2** overlaps with the gate bus line **112** to shield the domain line **DL4** produced in the edge portion **EG4** shown in FIG. 1, whereas the domain line **DL2** produced in the edge portion **EG2** shown in FIG. 1 is shielded by not just the portion of the upper subpixel electrode **111a1** overlapping with the gate bus line **112** but also by the black matrix (BM) as well.

[0160] Consequently, as far as CgdII is concerned, CgdII2 associated with the lower subpixel region is greater than CgdII1 associated with the upper subpixel region (i.e., CgdII2>CgdII1).

[0161] In the multi-domain pixel structure shown in FIG. 22, by making the width **L2** of the gate electrode **116G1** of the TFT **116a1** associated with the upper subpixel region broader than the width **L3** of the gate electrode **116G2** of the TFT **116a2** associated with the lower subpixel region, CgdI1 associated with the upper subpixel region is made greater than CgdI2 associated with the lower subpixel region (i.e., CgdI1>CgdI2) and CgdI1 + CgdII1 is substantially equalized with CgdI2 + CgdII2.

[0162] For example, the drain electrode **116D1** may have a length **L1** of about 25 μm , the gate electrode **116G1** may have a width **L2** of about 17 μm , the gate electrode **116G2** may have a width **L3** of about 16 μm , and the drain electrodes **116D1** and **116D2** may have a width **L4** of about 4 μm . In that case, the imbalance between Cgd1 and Cgd2 can be counteracted in a shielding structure in which the widths **L5** and **L8** of the respective broadened portions of the subpixel electrodes **111a1** and **111a2** are both approximately 10 μm , the widths **L6** and **L7** of the respective narrowed portions of the subpixel electrodes **111a1** and **111a2** are both approximately 3 μm , and the broadened portions of the subpixel electrodes **111a1** and **111a2** have lengths **L9** and **L10** of approximately 65 μm and approximately 82 μm , respectively. In this case, the broadened portion of the subpixel electrode **111a1** refers to the portion that has an increased overlapping width with the gate bus line **112**, while the narrowed portion of the subpixel electrode **111a1** refers to the portion that has a decreased overlapping width with the gate bus line **112**. Naturally, these dimensions depend on the respective dielectric constants and thicknesses of the gate insulating film **115**, the passivation film **118a** and the interlayer dielectric film **118b**, which are dielectric materials that define Cgd. This is also applicable to an arrangement with no interlayer dielectric film **118b**. In this example, the gate insulating film **115** and the passivation film **118a** were made of SiO₂ film with a relative dielectric constant of approximately 7 and a combined thickness of approximately 400 nm to approximately 1,000 nm and the interlayer dielectric film **118b** was made of a photosensitive resin with a relative dielectric constant of approximately 3 to 4 and a thickness of approximately 2-4 μm .

[0163] It also depends on the dimensions of a pixel region of the liquid crystal display device, the relative dielectric constant of the liquid crystal material (i.e., the magnitude of the liquid crystal capacitance) and the drive frequency how closely Cgd1 and Cgd2 should agree with each other. However, the present inventors confirmed via experiments that the occurrence of a flicker could be minimized or even eliminated as long as the difference in feedthrough voltages (i.e., the deviation of the counter electrode voltage) was equal to or smaller than 100 mV.

[0164] In the multi-domain pixel structure shown in FIG. 22, if the areas of overlap between the subpixel electrodes **111a1** and **111a2** and the gate bus line **112** are different between the two subpixel regions, then the two TFTs **116a** and **116b** associated with the two pixel regions have gate electrodes **116G1** and **116G2** with mutually different areas, thereby substantially equalizing Cgd1 and Cgd2 with each other. To satisfy this relation, however, any other arrangement may also be adopted.

[0165] For example, in the multi-domain pixel structure shown in FIG. 26, Cgd1 is increased by providing an extended portion for the drain electrode of the TFT associated with the upper subpixel region, thereby substantially equalizing Cgd1 and Cgd2 with each other.

[0166] On the other hand, in the multi-domain pixel structure shown in FIG. 27, the areas of overlap between the subpixel electrodes **111a1** and the gate bus line **112** are substantially equalized between the two subpixel regions by providing an extended portion **111a1E** for the subpixel electrode **111a1**, thereby substantially equalizing Cgd1 and Cgd2 with each other.

[0167] Still alternatively, the multi-domain pixel structure shown in FIG. 28 may also be adopted. In the multi-domain pixel structure shown in FIG. 28, drain extension lines **117-1** and **117-2** are arranged and connected to the respective drains of the two TFTs **116a1** and **116a2** associated with the upper and lower subpixel regions. In the upper subpixel region, a gate bus line extended portion **112E1**, branched from the gate bus line **112**, is arranged so as to include a portion that faces the drain extension line **117-1** connected to the TFT **116a1** with an insulating layer (typically a gate insulating film) interposed between them. That portion of the gate bus line extended portion **112E1** that faces the drain extension line **117-1** forms a capacitor (i.e., Cgd regulating portion **CGD-R1** shown in FIG. 28), which constitutes a component of Cgd1 of the TFT **116a1** of the upper subpixel region. In the multi-domain pixel structure shown in FIG. 28, the capacitance of the Cgd regulating portion **CGD-R1** is adjusted, thereby substantially equalizing Cgd1 and Cgd2

with each other.

[0168] In the multi-domain pixel structure shown in FIG. 28, the four liquid crystal domains shown in FIG. 1 are also formed in each of the upper and lower subpixel regions. That is why first through fourth opaque portions are preferably provided as described above so as to selectively shield darker areas (i.e., the domain lines DL1 through DL4 shown in FIG. 1) that appear parallel to the first through fourth edge portions (i.e., EG1 through EG4 shown in FIG. 1), respectively. Also, if an opaque member needs to be arranged inside the subpixel region, a central opaque portion is preferably defined by arranging that member such that the boundary areas where the first, second, third and fourth liquid crystal domains are adjacent to the other liquid crystal domains are selectively shielded from the incoming light.

[0169] In this example, the gate bus line extended portion 112E1 provided for the upper subpixel region forms at least a part of the third opaque portion that shields the third edge portion (i.e., EG3 shown in FIG. 1). Also, at least a part of the first opaque portion that shields the first edge portion (i.e., EG1 shown in FIG. 1) in the upper subpixel region is defined by the CS bus line extended portion 113E1. On the other hand, in the lower subpixel region, at least a part of the third opaque portion is defined by the CS bus line extended portion 113E2 and at least a part of the first opaque portion is defined by a gate metal layer island opaque portion 116GSI that is made of the same layer as the gate bus line 112.

[0170] Furthermore, the fourth edge portion (i.e., EG4 shown in FIG. 1) in the upper subpixel region is shielded by increasing the width of overlap between the CS bus line 113 and the subpixel electrode 111a1 with an extended portion defined by partially increasing (upward in this case) the width of the subpixel electrode 111a1. Also, an extended portion of the drain extension line 117-1 is provided in a region including the extended portion of the subpixel electrode 111a1, thereby forming a storage capacitor CS and contributing to shielding the fourth edge portion, too. On the other hand, the second edge portion (i.e., EG2 shown in FIG. 1) in the upper subpixel region is shielded by increasing the width of overlap between the gate bus line 112 and the subpixel electrode 111a1 with an extended portion defined by partially increasing (downward in this case) the width of the subpixel electrode 111a1. A portion of the drain extension line 117-1 arranged in the vicinity of the second edge portion also contributes to shielding the second edge portion.

[0171] Furthermore, the fourth edge portion in the lower subpixel region is shielded by increasing the width of overlap between the gate bus line 112 and the subpixel electrode 111a2 with an extended portion defined by partially increasing (upward in this case) the width of the subpixel electrode 111a2. On the other hand, the second edge portion in the lower subpixel region is shielded by increasing the width of overlap between the CS bus line 113 and the subpixel electrode 111a2 with an extended portion defined by partially increasing (downward in this case) the width of the subpixel electrode 111a2. Also, an extended portion of the drain extension line 117-2 is provided in a region including the extended portion of the subpixel electrode 111a2, thereby forming a storage capacitor CS and contributing to shielding the fourth edge portion, too.

[0172] The multi-domain pixel structure shown in FIG. 28 adopts an arrangement in which the drain extension line 117-1 partially overlaps with the CS bus line extended portion 112E1 and in which the drain extension line 117-2 partially overlaps with the CS bus line extended portion 113E2. The drain extension lines 117-1, 117-2, the CS bus line extended portions 113E1, 113E2 and the insulating layer (a gate insulating film in this case) interposed between them form respective parts of the storage capacitor CS of each pixel region. If a sufficient capacitance value is achieved by the storage capacitor CS that is formed in the respective extended portions of the subpixel electrodes 111a1 and 111a2, then there is no need to form a storage capacitor with the CS bus line extended portions 113E1 and 113E2.

[0173] In the example illustrated in FIG. 28, the Cgd regulating portion CGD-R1 is provided for only the upper subpixel region. However, another Cgd regulating portion may be provided for the lower subpixel region, too. In that case, the gate bus line extended portion of the lower subpixel region is preferably arranged so as to also function as an opaque portion. Also, in the example illustrated in FIG. 28, each of the upper and lower subpixel regions has the multi-domain pixel structure shown in FIG. 1. That is why the lower subpixel region has no edge portion to be shielded with a gate bus line extended portion. However, if the lower subpixel region has the multi-domain pixel structure shown in FIG. 2(b) or 3(b), for example, then the second edge portion (DL2 shown in FIG. 2(b)) or the third edge portion (DL3(V) shown in FIG. 3(b)) can be shielded effectively by providing a gate bus line extended portion. If the Cgd regulating portions are provided for both of the upper and lower subpixel regions in this manner, Cgd1 and Cgd2 may be substantially equalized with each other by adjusting their areas.

[0174] FIG. 29 schematically illustrates an example in which the upper and lower subpixel regions have the multi-domain pixel structures shown in FIGS. 1 and 3(b), respectively, and in which Cgd regulating portions (1) and (2) are provided for the upper and lower subpixel regions, respectively.

[0175] In this example, the Cgd regulating portion CGD-R1 of the upper subpixel region has a bigger area than the Cgd regulating portion CGD-R2 of the lower subpixel region. This arrangement is adopted to compensate for the deficit of the area of overlap between the upper subpixel electrode 111a1 and the gate bus line 112, which is smaller than the area of overlap between the lower subpixel electrode 111a2 and the gate bus line 112, and thereby equalize Cgd1 and Cgd2 with each other.

[0176] Also, in the Cgd regulating portions CGD-R1 and CGD-R2, the right ends of the drain extension lines 117-1

and **117-2** overlap with the gate bus line extended portions **112E1** and **112E2**, respectively. Thus, if the drain extension lines **117-1** and **117-2** were misaligned horizontally, the capacitance values of the Cgd regulating portions would change. On the other hand, the portions of the TFTs **116a1** and **116a2** that form Cgd parasitic capacitors are arranged such that the left ends of the drain extension lines **117-1** and **117-2** (or drain electrodes **116D1** and **116D2**) overlap with the gate electrodes **116G1** and **116G2** (defined by portions branched from the gate bus line). Thus, if the drain extension lines (drain electrodes) **117** were misaligned horizontally, the capacitance values of the Cgd regulating portions would also change. The right ends of drain extension lines **117-1** and **117-2** that form the Cgd regulating portions and the left ends of the drain extension lines **117-1** and **117-2** that form the Cgd parasitic capacitors of the TFTs are arranged on mutually opposite sides horizontally. That is why if the drain extension lines (or drain electrodes) **117-1** and **117-2** were misaligned either to the right or to the left, one of the two capacitance values would increase and the other capacitance value would decrease. For that reason, by substantially equalizing the widths of the drain extension lines **117-1** and **117-2** at the right and left ends, even if the drain extension lines **117-1** and **117-2** were misaligned horizontally, the sum of the Cgd capacitances (i.e., the capacitance value of the Cgd parasitic capacitor of the TFT and that of the Cgd regulating portion) could be kept constant effectively.

[0177] In the example described above, Cgd1 and Cgd2 of the two TFTs provided for the two subpixel regions are substantially equalized with each other by setting (1) the areas of the gate electrodes, (2) the areas of the drain electrodes, (3) the areas of overlap between the subpixel electrodes and the gate bus line, and (4) the areas of overlap between the drain extension lines and the gate bus line independently of each other. Optionally, Cgd1 and Cgd2 may also be equalized with each other by setting two or more of these four sets of values (1) to (4) in any arbitrary combination.

[0178] Furthermore, in the example described above, the areas of the subpixel regions (or subpixel electrodes) are supposed to be equal to each other. However, the present invention is in no way limited to that specific preferred embodiment. For example, even if the ratios of the areas of the subpixel regions are changed into one to three, the settings may also be adjusted so as to equalize the drain-gate capacitance values Cgd of the two TFTs with each other.

INDUSTRIAL APPLICABILITY

[0179] A liquid crystal display device according to the present invention can be used effectively as a TV monitor or in any other application that requires high display quality.

Claims

1. A liquid crystal display device comprising:

a vertical alignment liquid crystal layer;
a first substrate and a second substrate, which face each other with the liquid crystal layer interposed between them; and
at least one alignment film, which is arranged in contact with the liquid crystal layer,

wherein the first substrate includes a TFT, a gate bus line, a source bus line and a storage capacitor line, and wherein each pixel region includes two subpixel regions, in which mutually different voltages are applied to the liquid crystal layer with respect to a signal voltage that has been supplied from the source bus line by way of their associated TFTs, and

wherein the first substrate further includes a first electrode, which is provided for each of the two subpixel regions, and wherein the second substrate includes a second electrode, which is arranged so as to face the first electrode with the liquid crystal layer interposed between them, and

wherein a liquid crystal capacitor, formed by the first and second electrodes and the liquid crystal layer between the first and second electrodes, is provided for each said subpixel region, and

wherein each said subpixel region includes at least one liquid crystal domain that produces a dark area, which looks darker than a gray scale tone being presented for a viewer located in front of the device, inside of, and substantially parallel to, an edge portion of the first electrode, and

wherein at least a part of the edge portion of the first electrode is arranged so as to overlap with the gate bus line and selectively shield at least a part of the dark area from incoming light, and

wherein two TFTs associated with the two subpixel regions have substantially equal drain-gate capacitances Cgd.

2. The liquid crystal display device of claim 1, wherein the gate electrodes of the two TFTs associated with the two subpixel regions have mutually different areas.

3. The liquid crystal display device of claim 1 or 2,
wherein the drain electrodes of the two TFTs associated with the two subpixel regions have mutually different areas.

5 4. The liquid crystal display device of one of claims 1 to 3, wherein a portion of the first electrode overlapping with the gate bus line, including the edge portion, in one of the two subpixel regions has a different area from the overlapping portion of the first electrode in the other subpixel region.

10 5. The liquid crystal display device of one of claims 1 to 3, wherein a portion of the first electrode overlapping with the gate bus line, including the edge portion, in one of the two subpixel regions has the same area as the overlapping portion of the first electrode in the other subpixel region.

6. The liquid crystal display device of one of claims 1 to 5, further comprising:

15 drain extension lines, which are connected to the respective drains of the two TFTs associated with the two subpixel regions; and
gate bus line extended portions, which branch from the gate bus line,

20 wherein each said gate bus line extended portion includes a portion that faces its associated drain extension line that is connected to one of the two TFTs with an insulating layer interposed between them.

25 7. The liquid crystal display device of claim 6, wherein each of the two subpixel regions further includes first, second, third and fourth liquid crystal domains in which liquid crystal molecules are tilted in first, second, third and fourth directions, respectively, around the center of the plane, and approximately at the middle of the thickness, of the liquid crystal layer in response to a voltage applied, the first, second, third and fourth directions being defined such that an angle formed between any two of the four directions is approximately equal to an integral multiple of 90 degrees, and

30 wherein the first liquid crystal domain is located close to at least a part of an edge of the first electrode, the part including a first edge portion in which an azimuthal direction that is perpendicular to the part and that points toward the inside of the first electrode defines an angle greater than 90 degrees with respect to the first direction, and
wherein the second liquid crystal domain is located close to at least a part of another edge of the first electrode, the part including a second edge portion in which an azimuthal direction that is perpendicular to the part and that points toward the inside of the first electrode defines an angle greater than 90 degrees with respect to the second direction, and

35 wherein the third liquid crystal domain is located close to at least a part of still another edge of the first electrode, the part including a third edge portion in which an azimuthal direction that is perpendicular to the part and that points toward the inside of the first electrode defines an angle greater than 90 degrees with respect to the third direction, and
wherein the fourth liquid crystal domain is located close to at least a part of yet another edge of the first electrode, the part including a fourth edge portion in which an azimuthal direction that is perpendicular to the part and that points toward the inside of the first electrode defines an angle greater than 90 degrees with respect to the fourth direction, and

40 wherein either the first or second substrate has an opaque member that includes first, second, third and fourth opaque portions for selectively shielding at least respective parts of the first, second, third and fourth edge portions from incoming light, and a central opaque portion for shielding at least a part of a boundary area, where each of the first, second, third and fourth liquid crystal domains is adjacent to another one of these four liquid crystal domains, from incoming light, and
45 wherein the central opaque portion includes a part of the drain extension line.

50 8. The liquid crystal display device of claim 7, wherein if the horizontal direction of a display screen has an azimuthal angle of zero degrees, the first, second, third and fourth directions are an approximately 225 degree direction, an approximately 315 degree direction, an approximately 45 degree direction and an approximately 135 degree direction, respectively, and

wherein the first and third edge portions are parallel to a vertical direction and the second and fourth edge portions are parallel to the horizontal direction, and

55 wherein in one of the two subpixel regions, the third opaque portion includes at least a part of the gate bus line extended portion.

9. The liquid crystal display device of claim 7 or 8,
wherein in one of the two subpixel regions, the first opaque portion includes at least a part of the storage capacitor

line extended portion.

10. The liquid crystal display device of one of claims 7 to 9, wherein in the other subpixel region, the third opaque portion includes at least a part of the storage capacitor line extended portion.

5 11. The liquid crystal display device of one of claims 7 to 10, wherein in the other subpixel region, the first opaque portion includes at least a part of an island opaque portion that is made of the same layer as the gate bus line.

10 12. The liquid crystal display device of one of claims 1 to 11, wherein the feedthrough voltages of the two subpixel regions have a difference of 100 mV or less.

15

20

25

30

35

40

45

50

55

FIG. 1

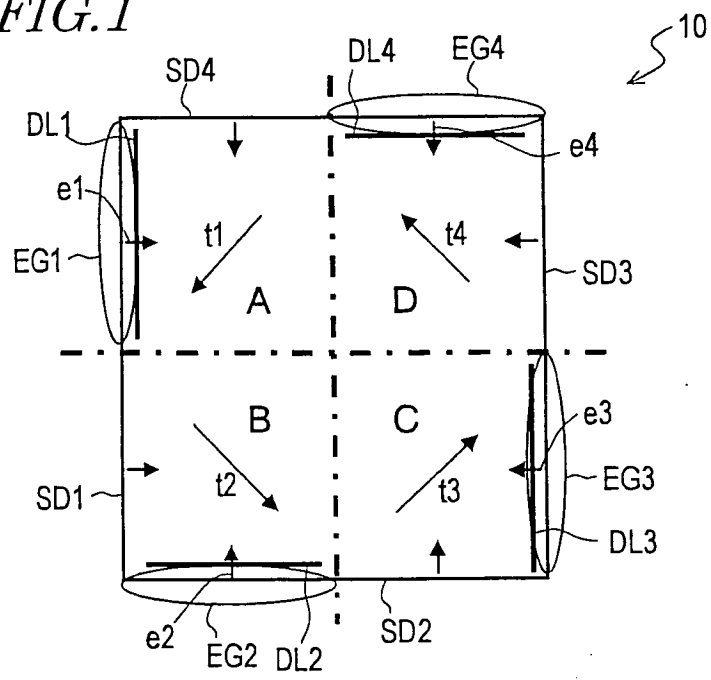

FIG. 2

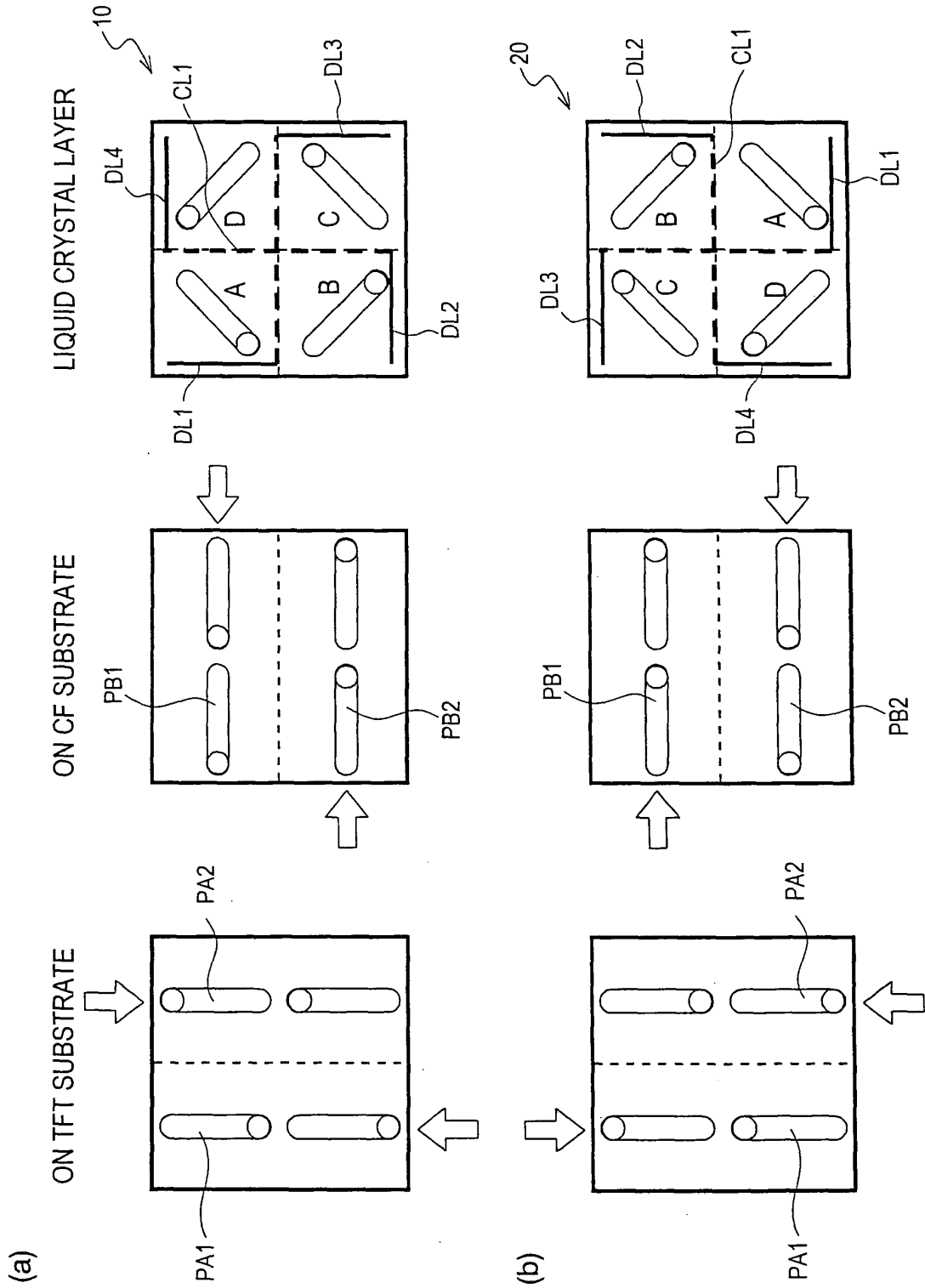

FIG. 3

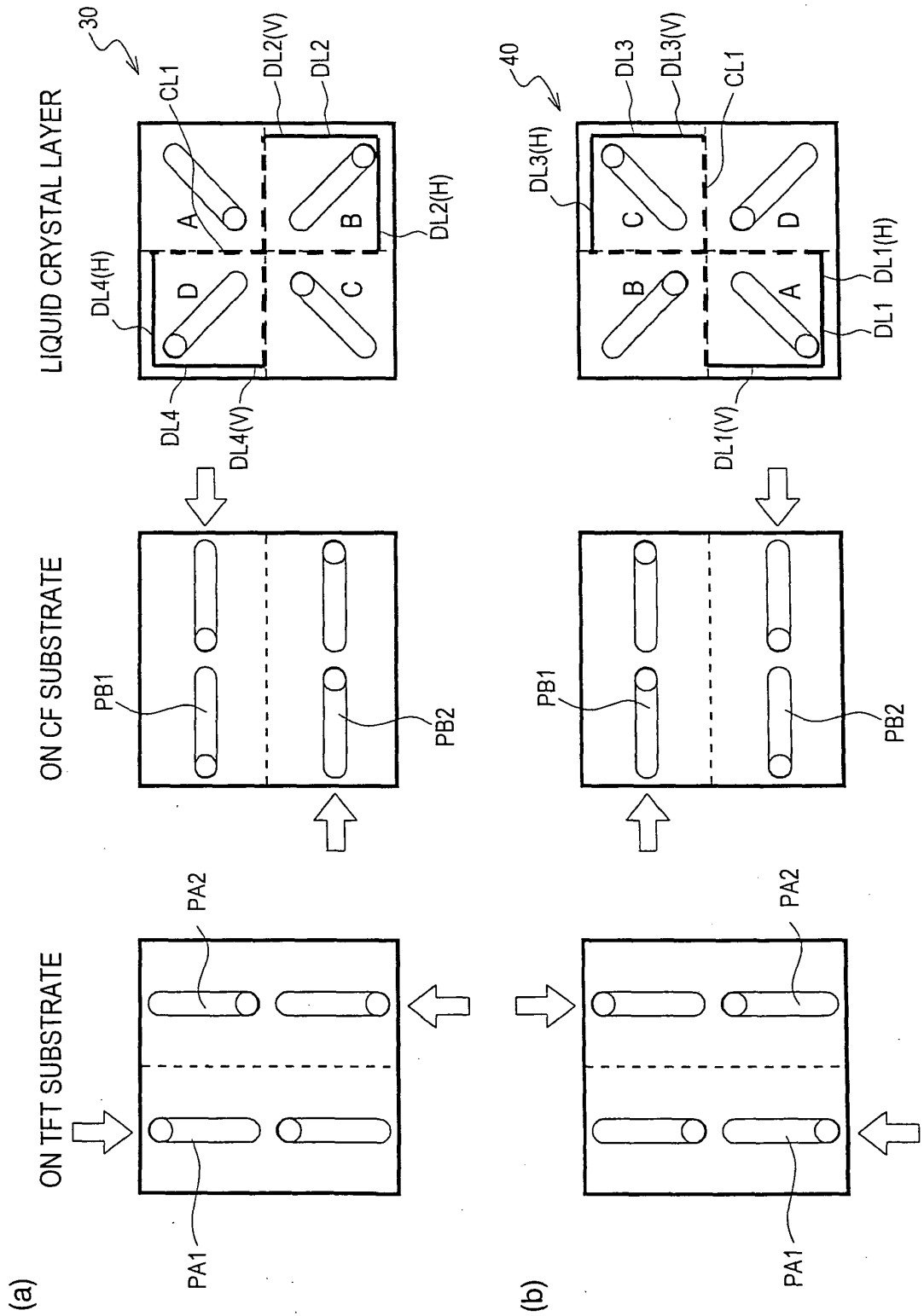
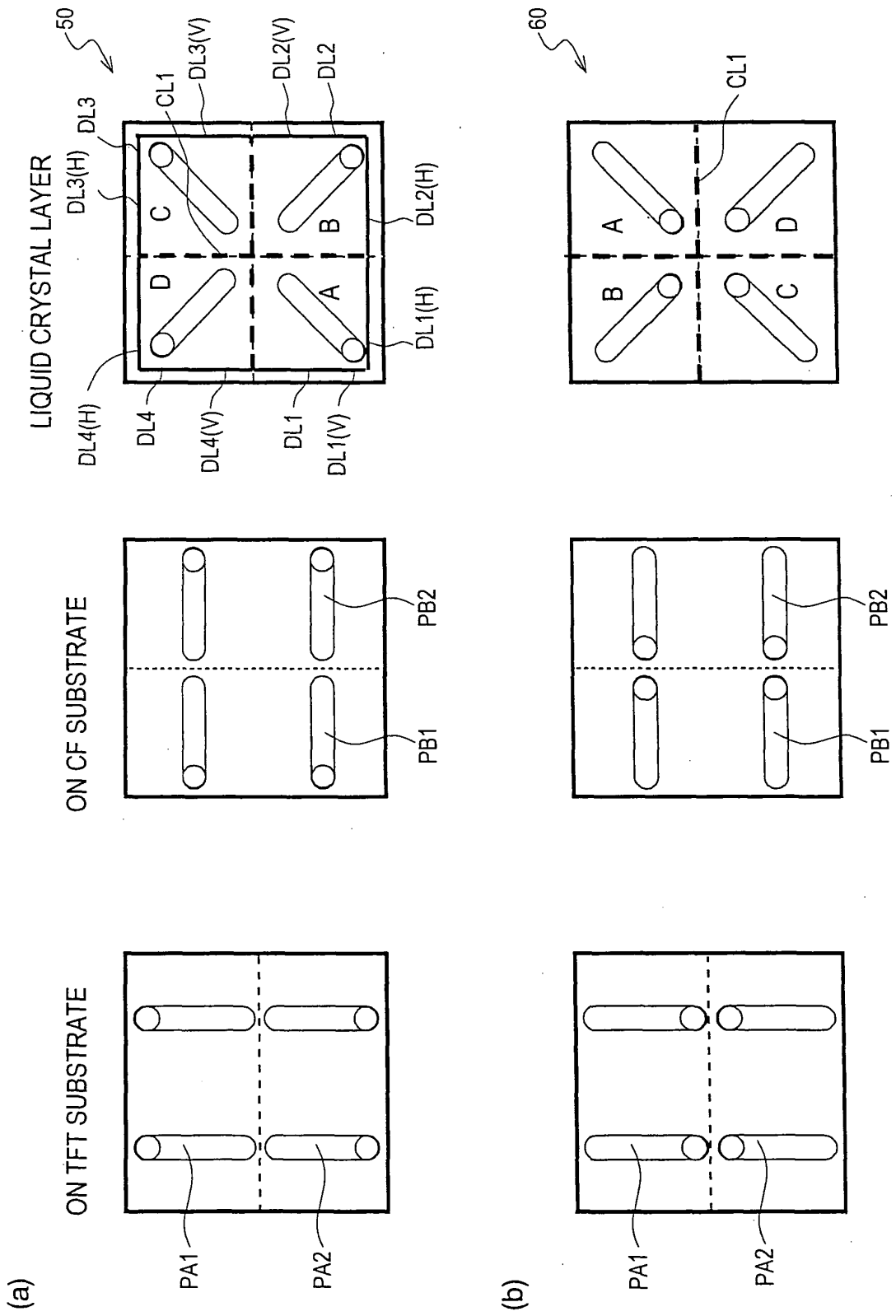

FIG. 4



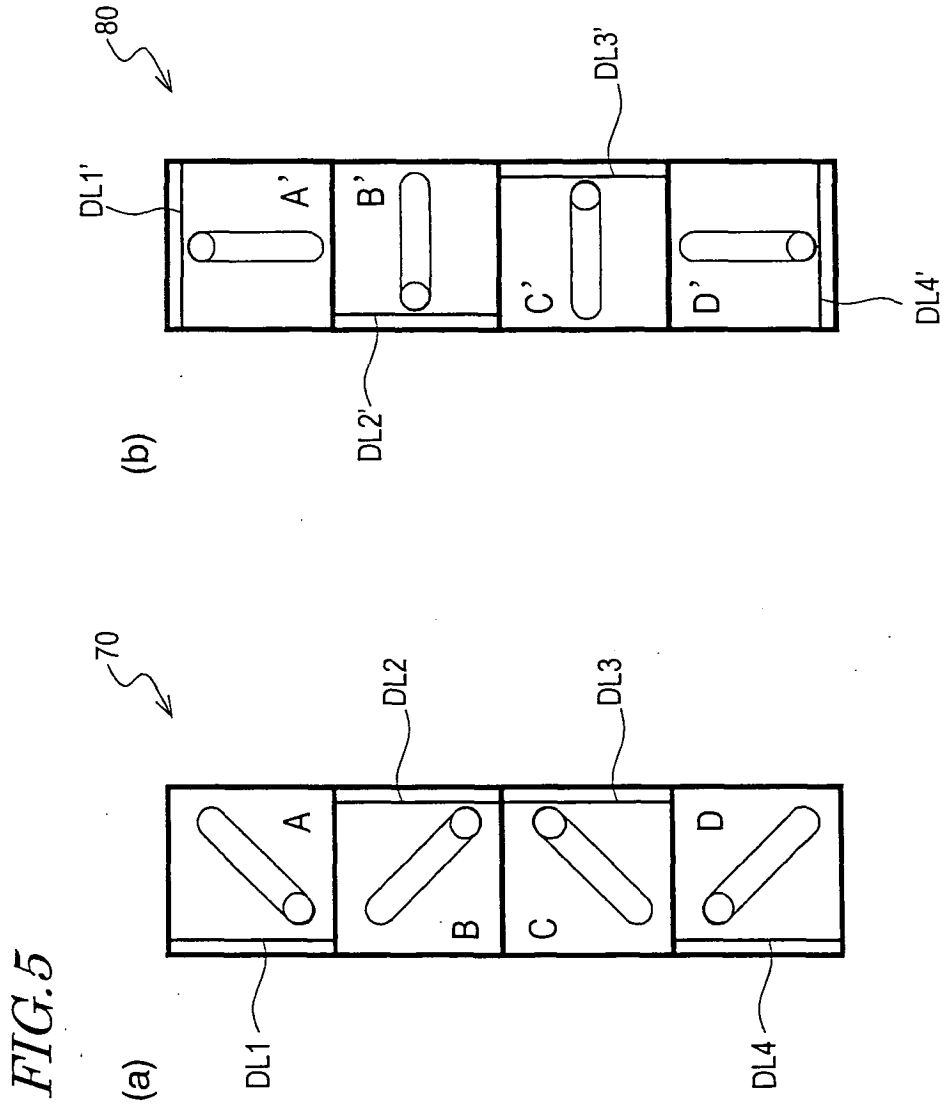
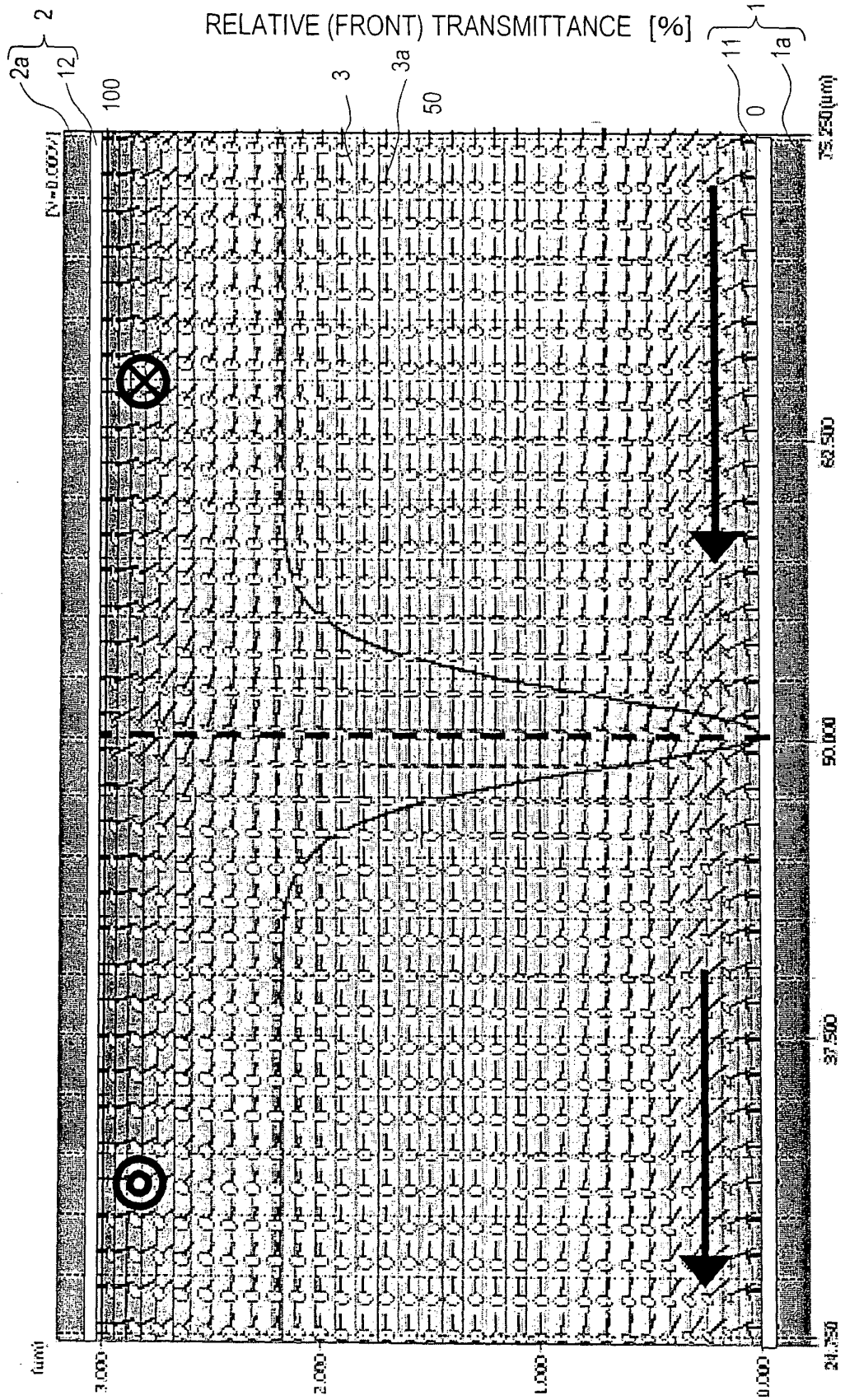
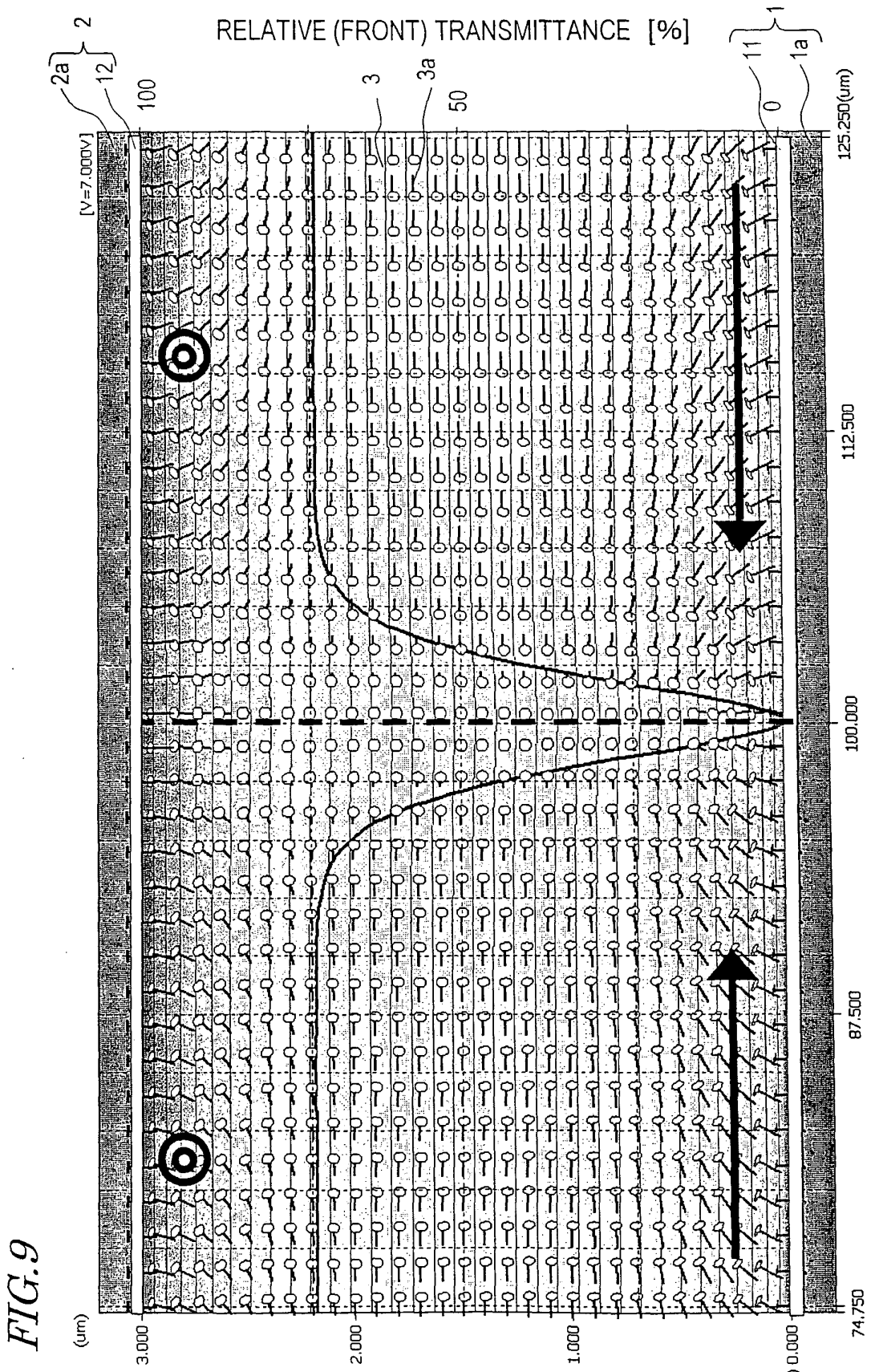

FIG. 8





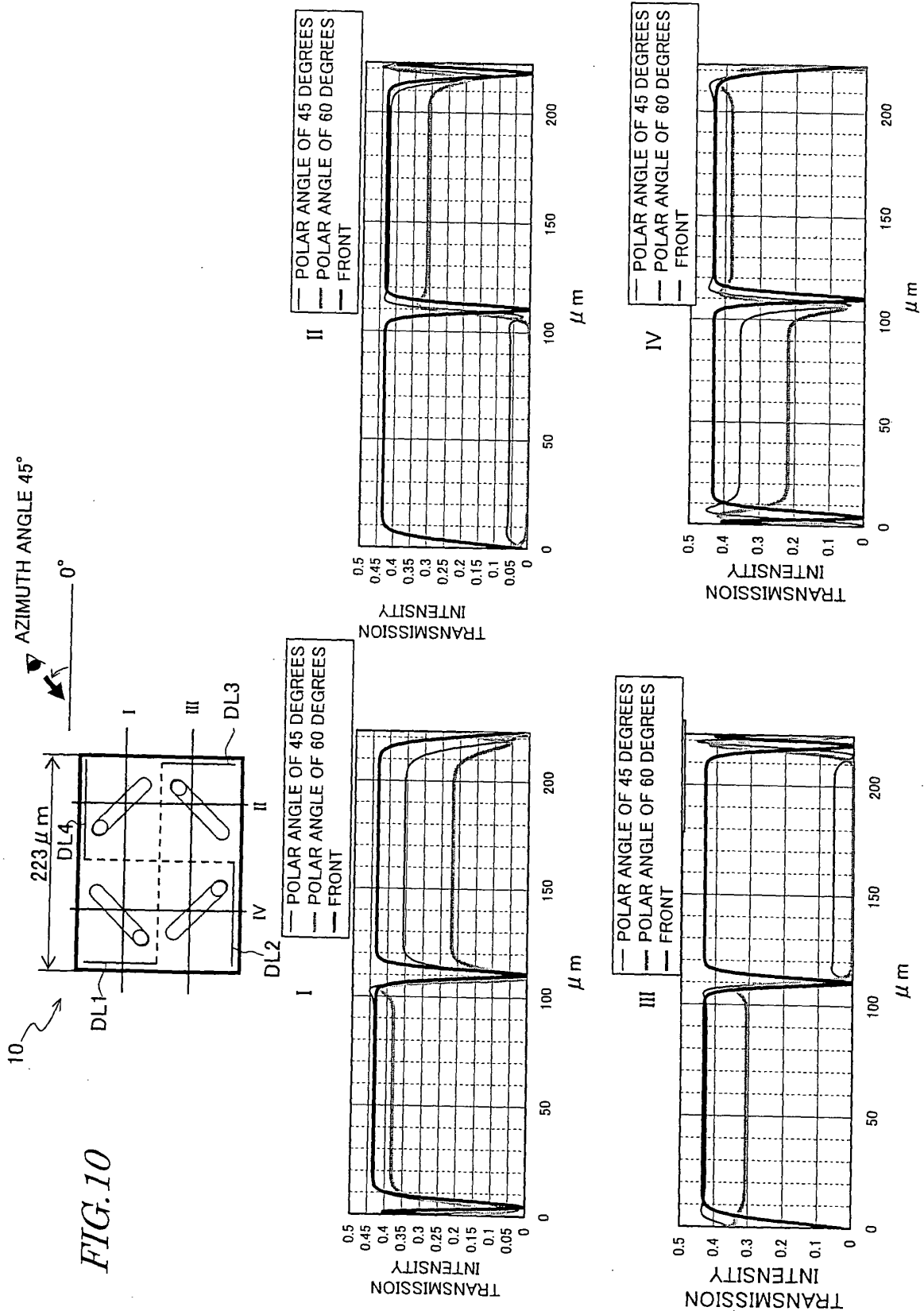

FIG. 11

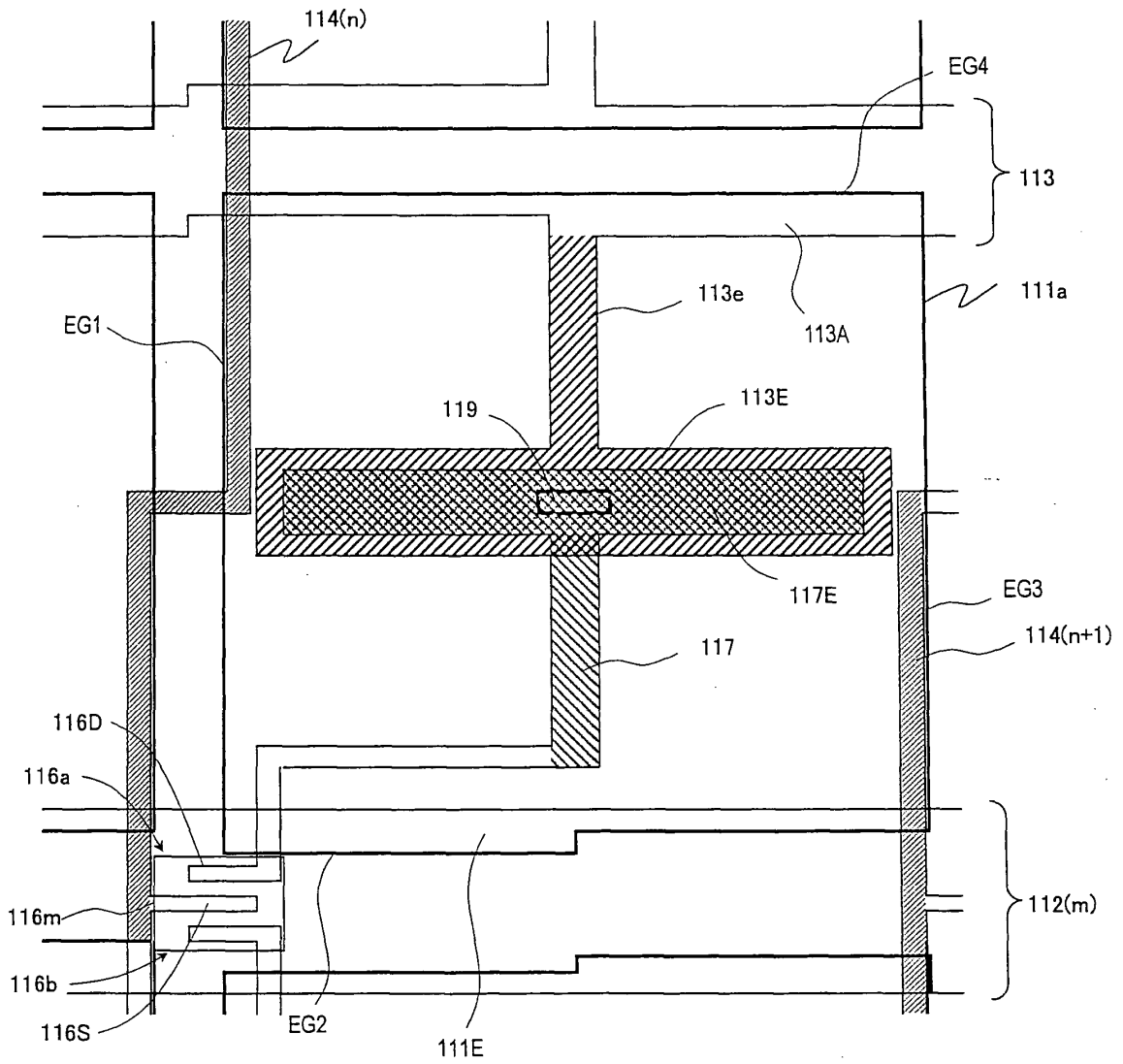

FIG. 12

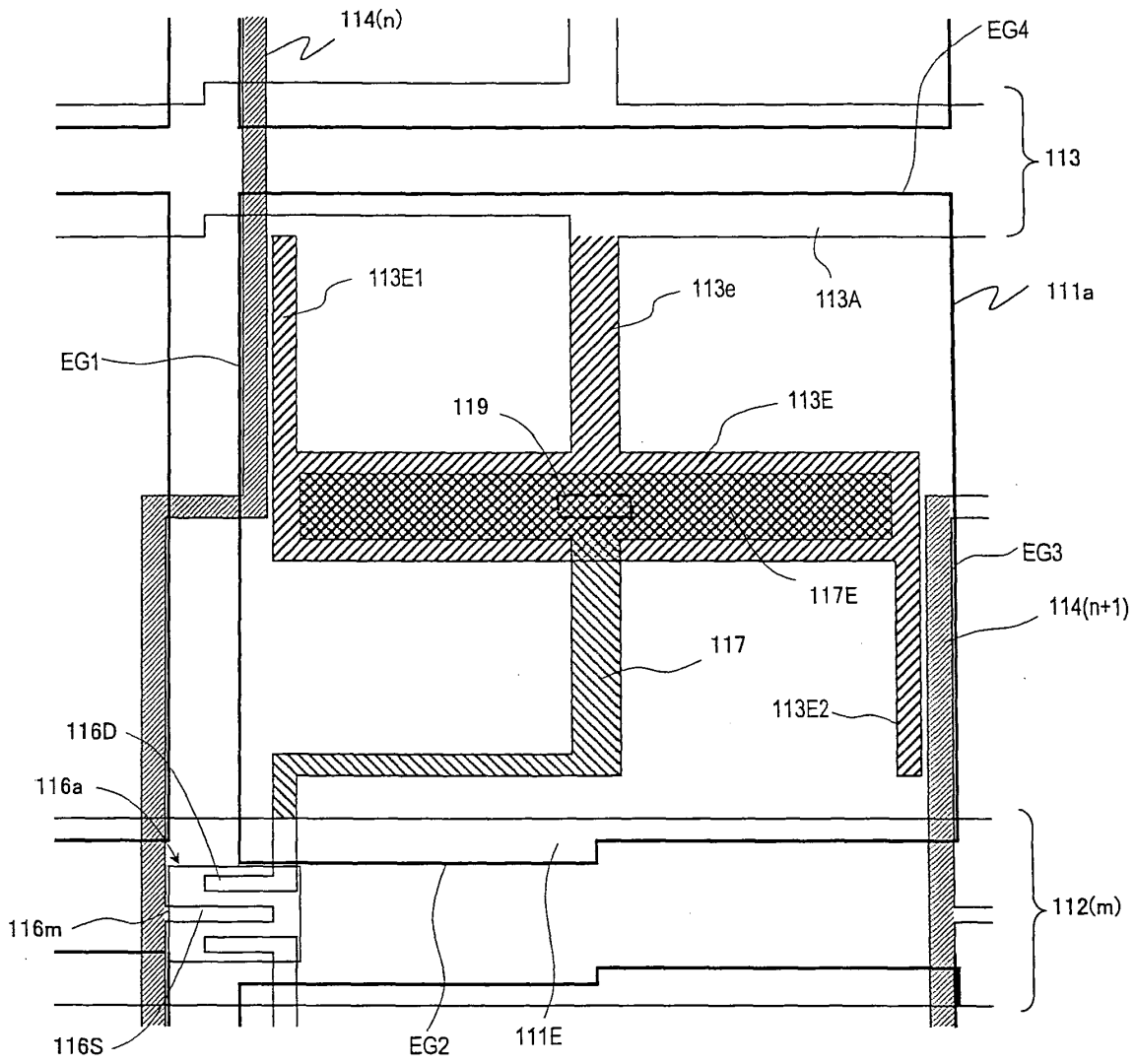

FIG. 13

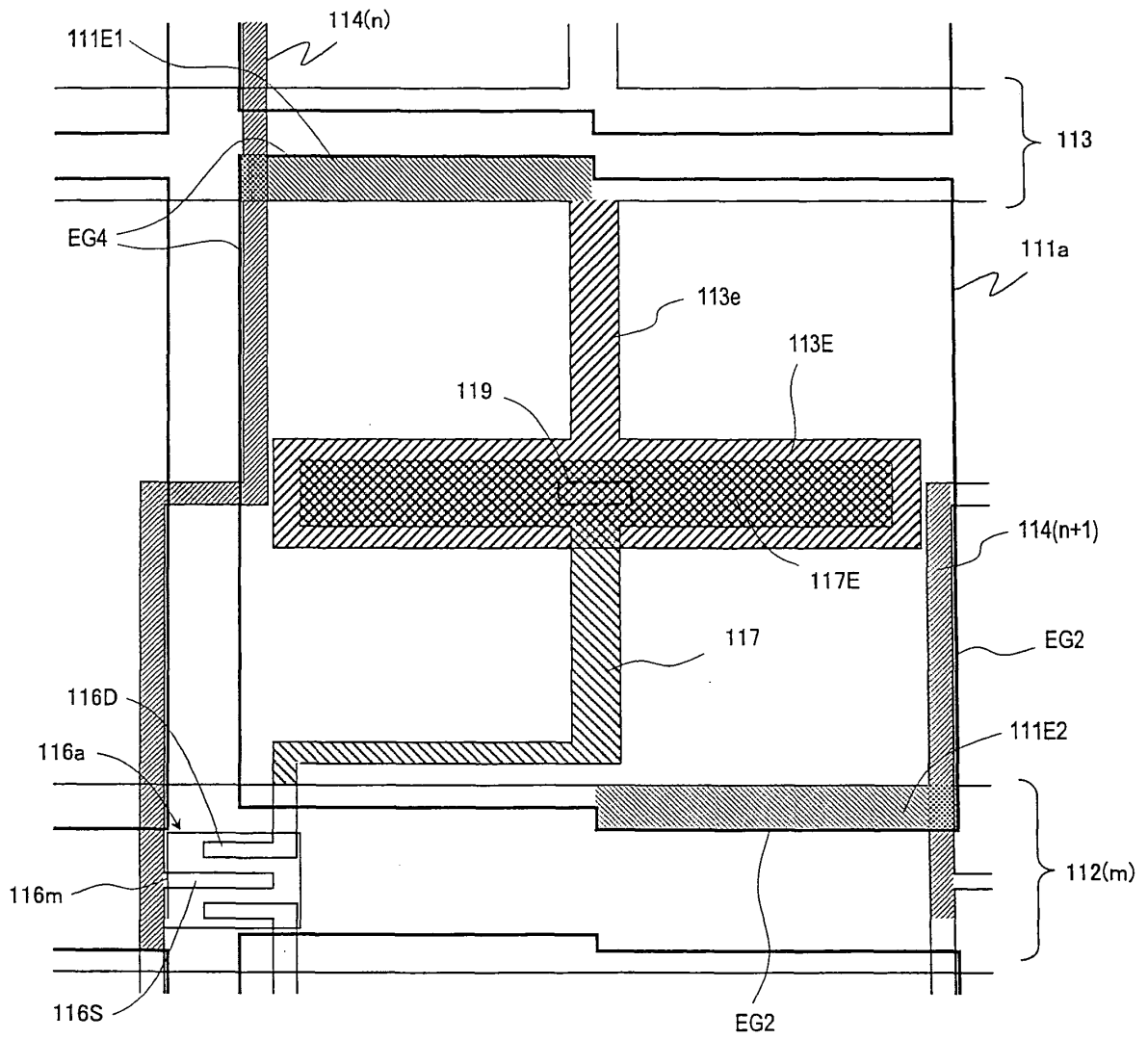
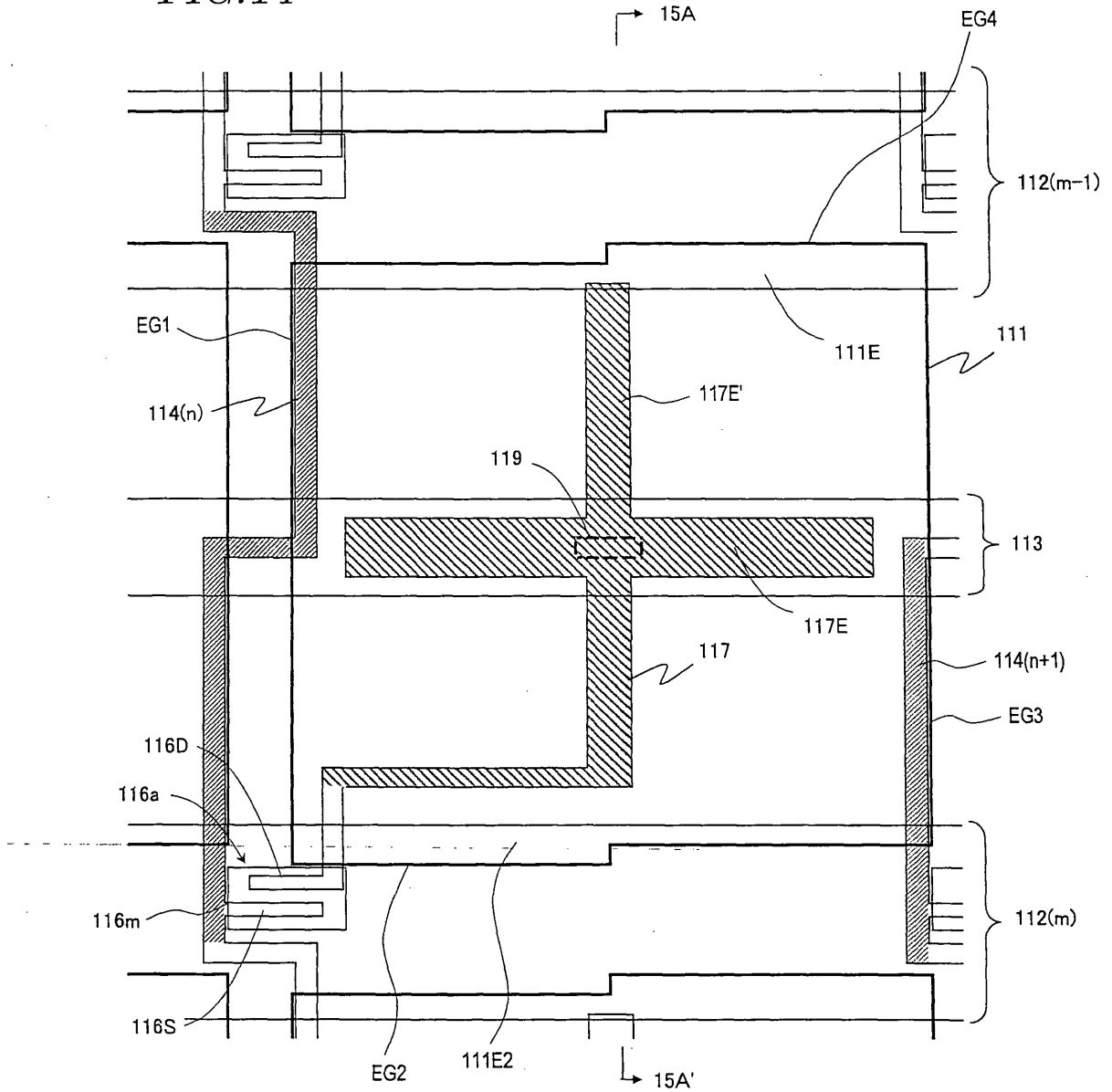

FIG. 14



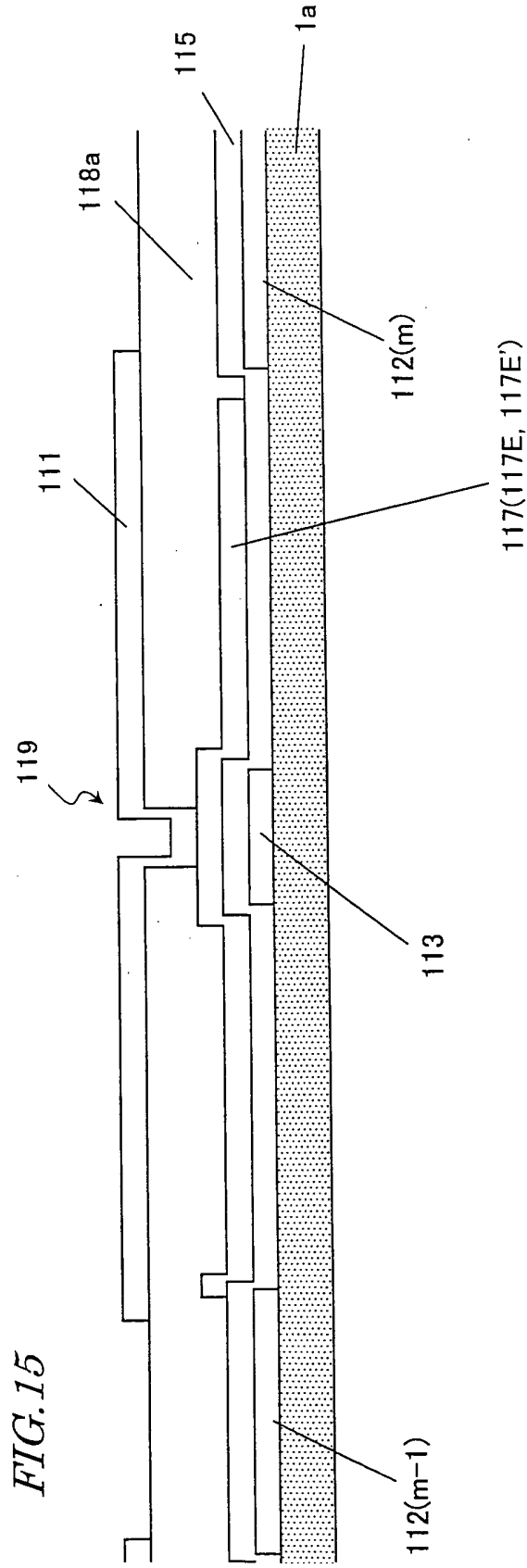

FIG. 16

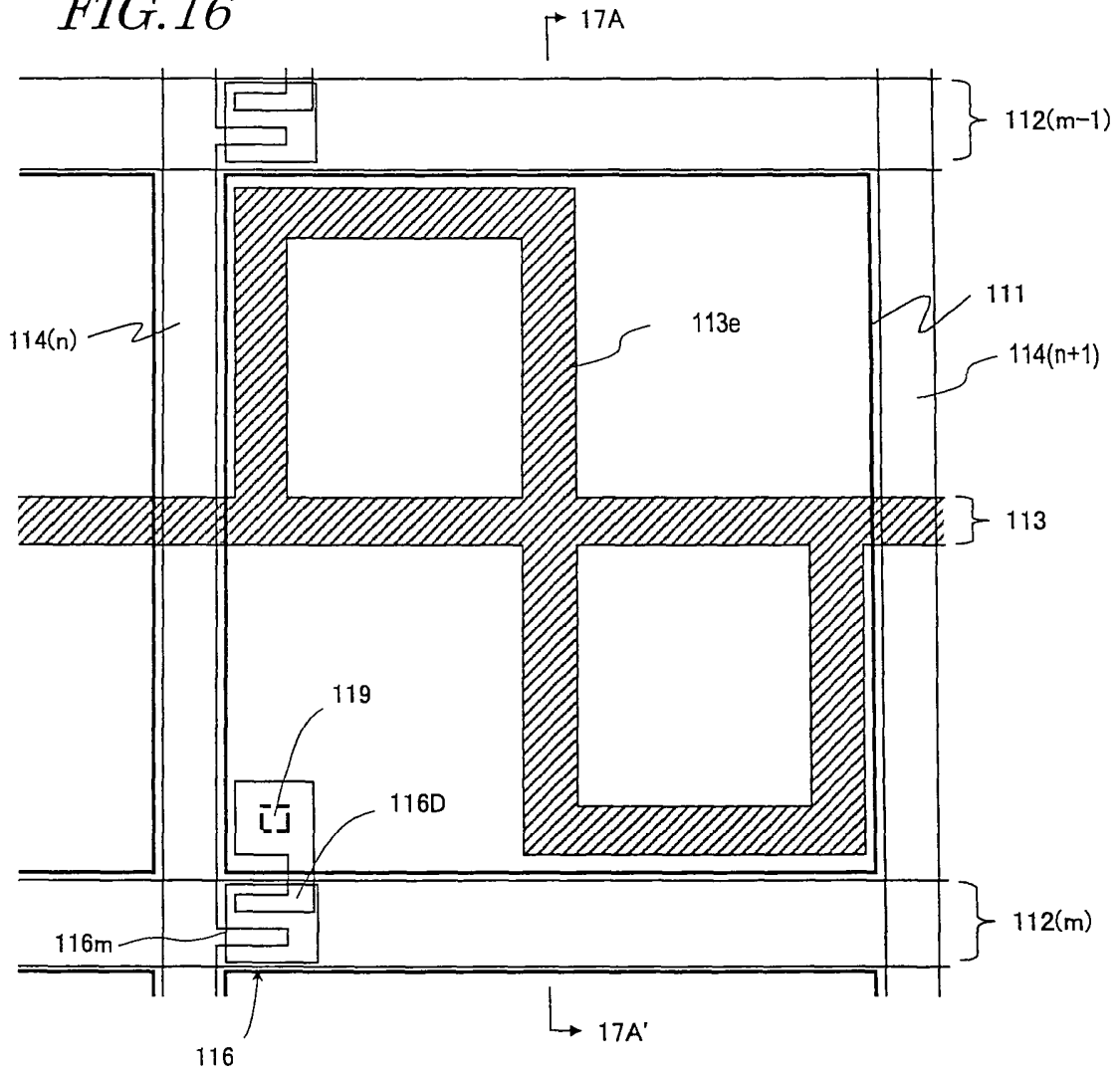

FIG. 17

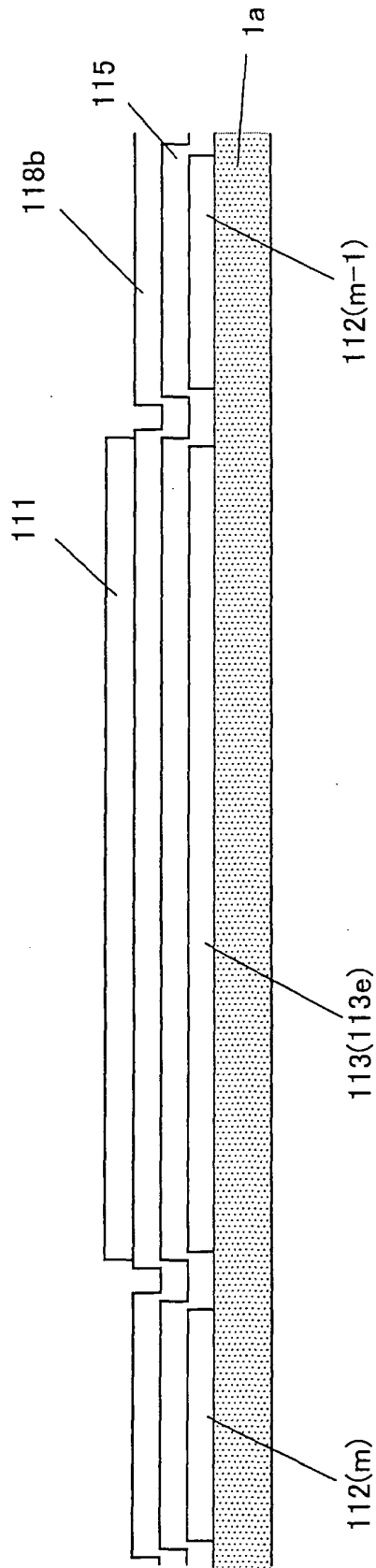

FIG. 18

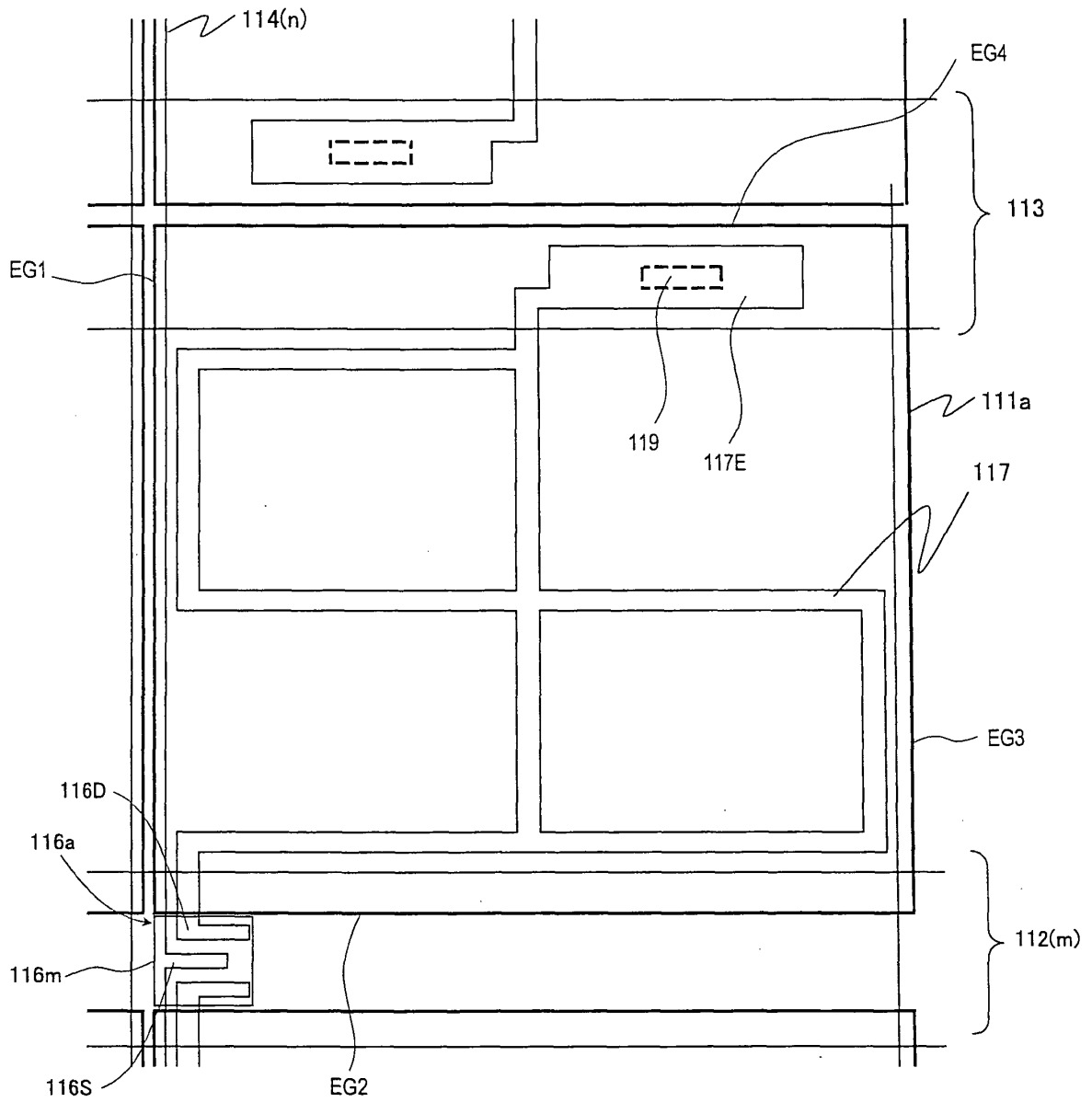

FIG. 19

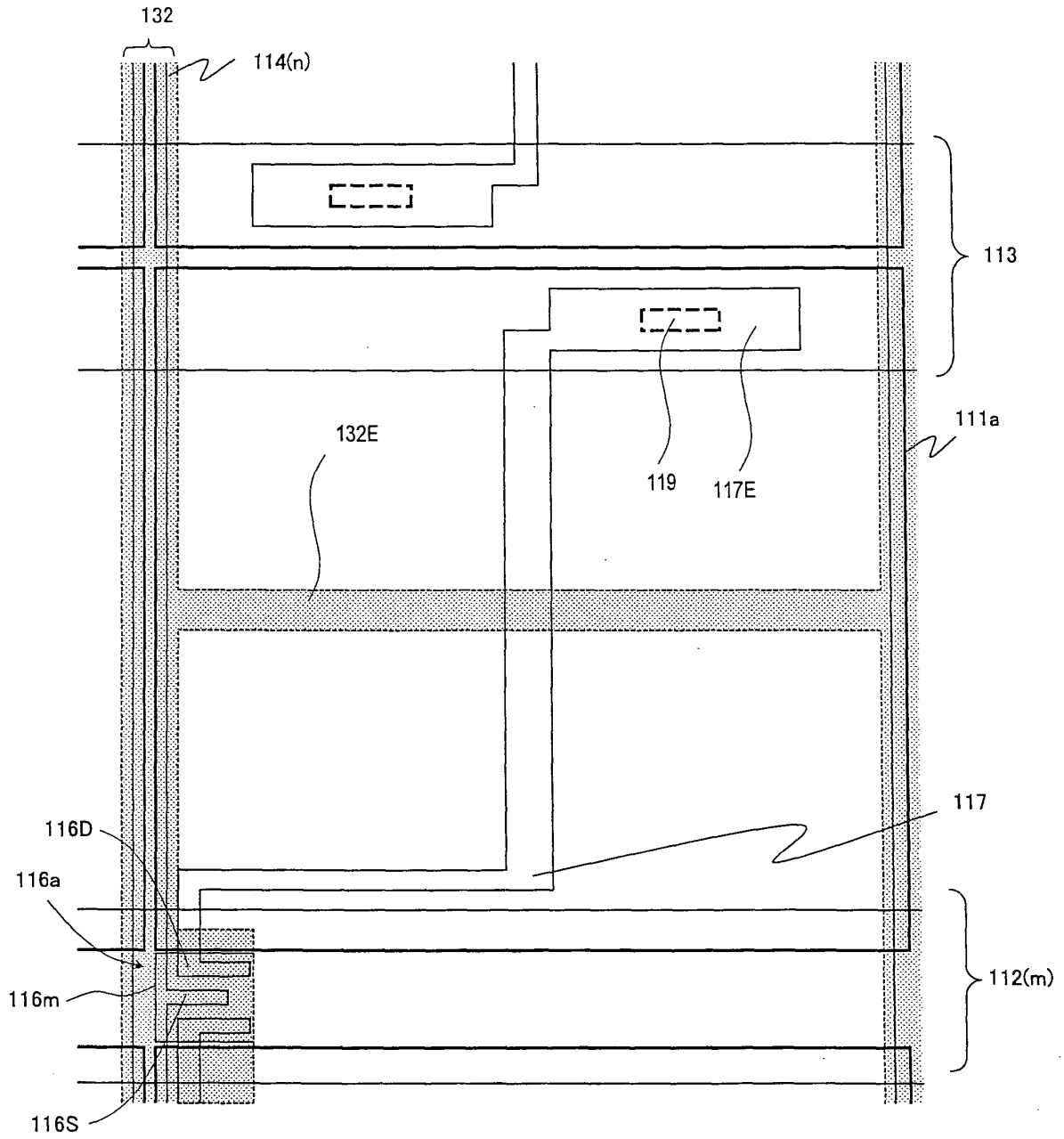

FIG. 20

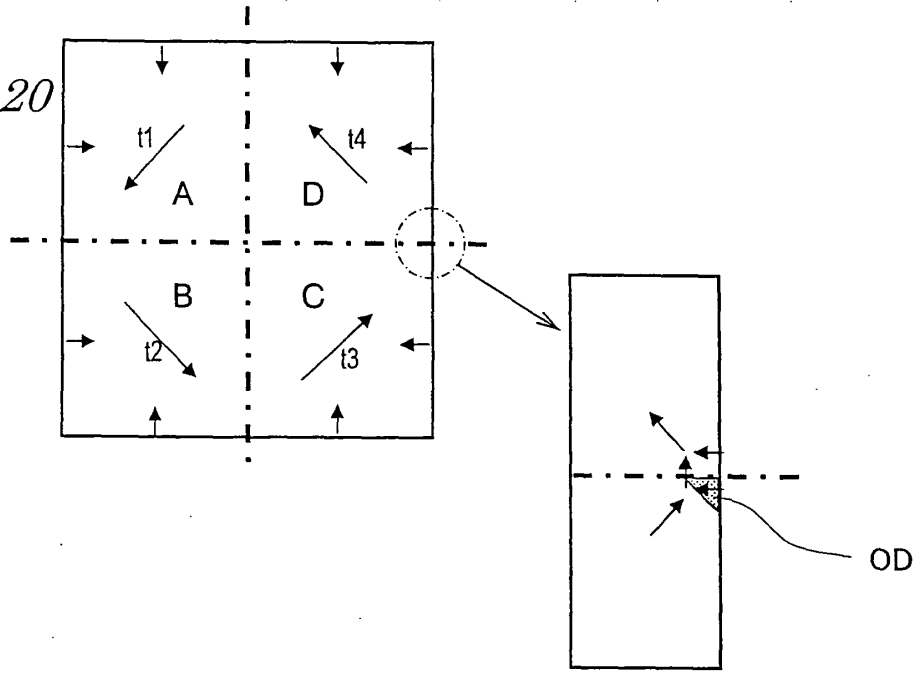

FIG. 21

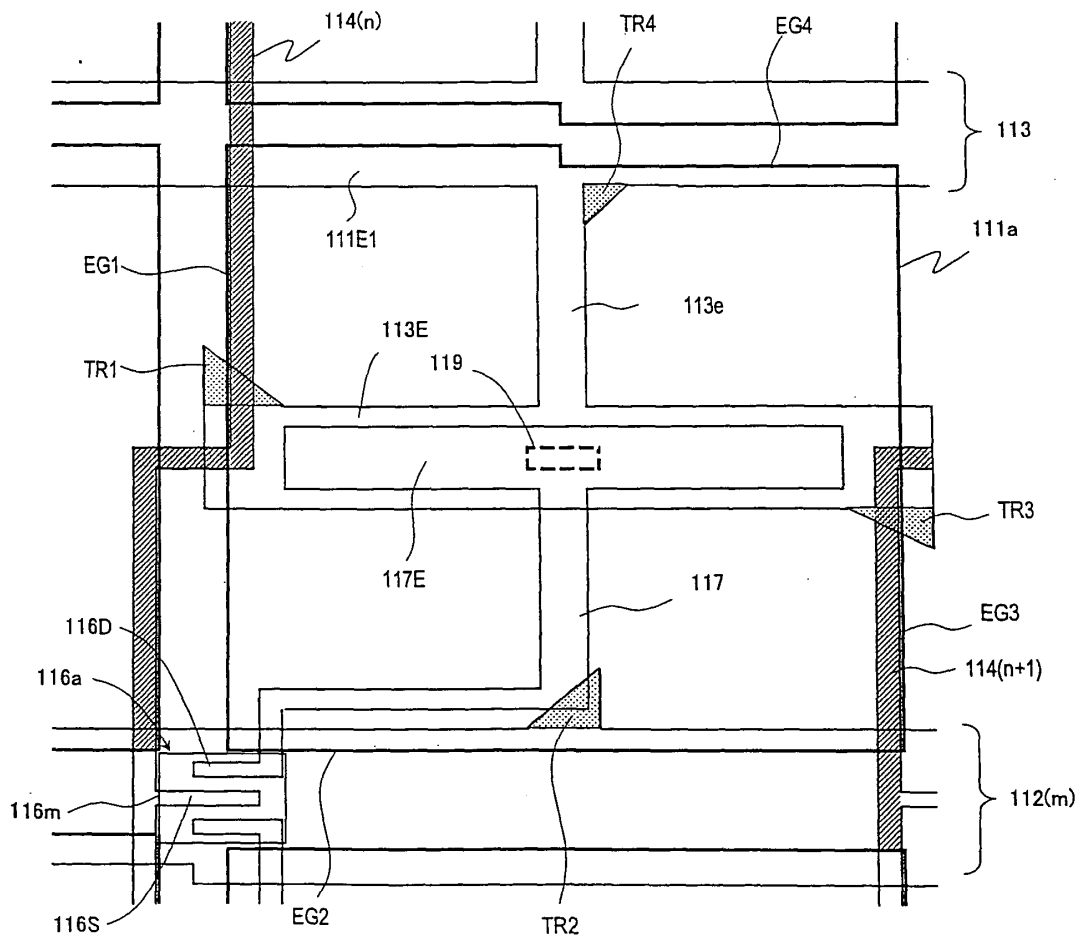

FIG. 22

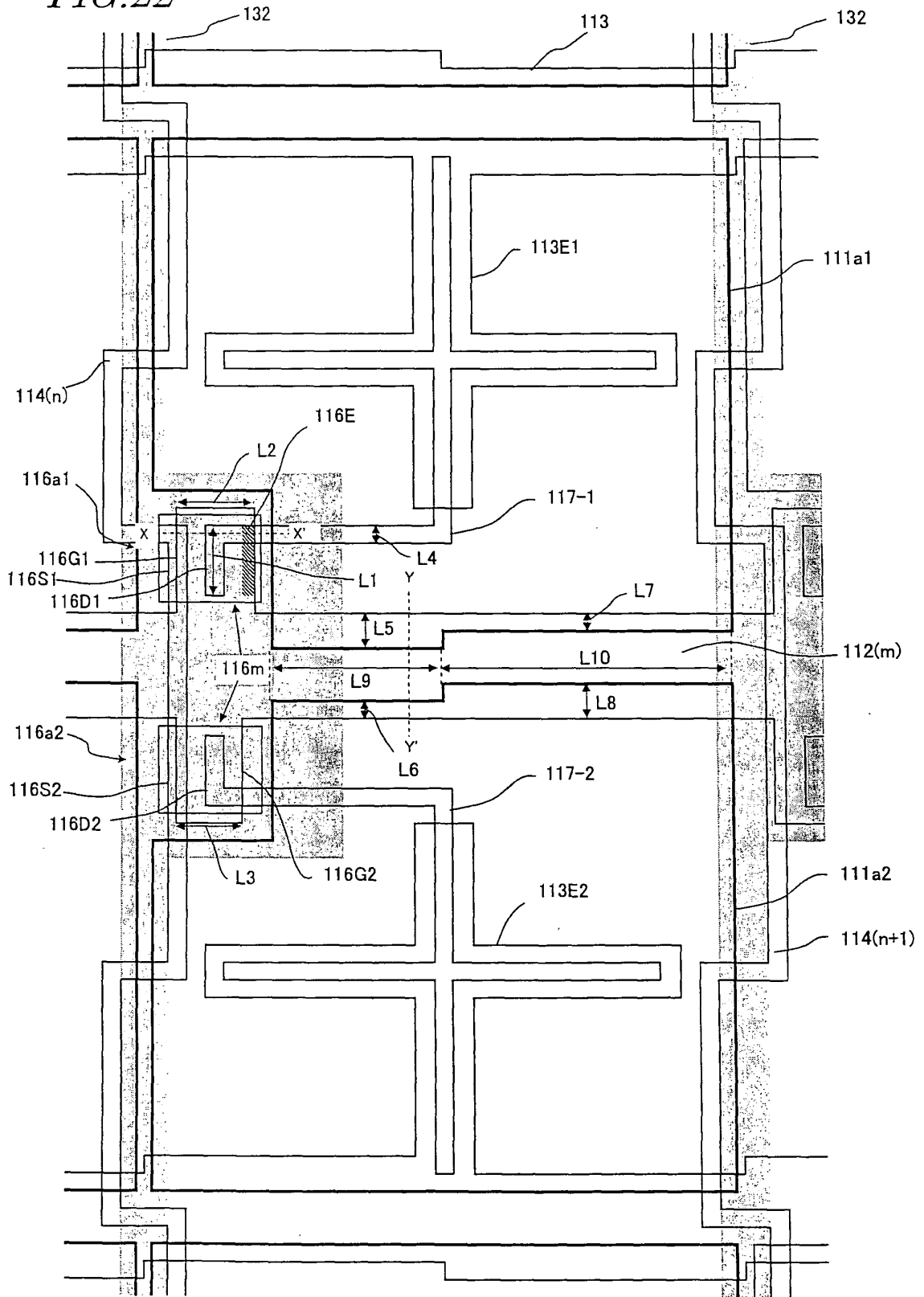

FIG. 23

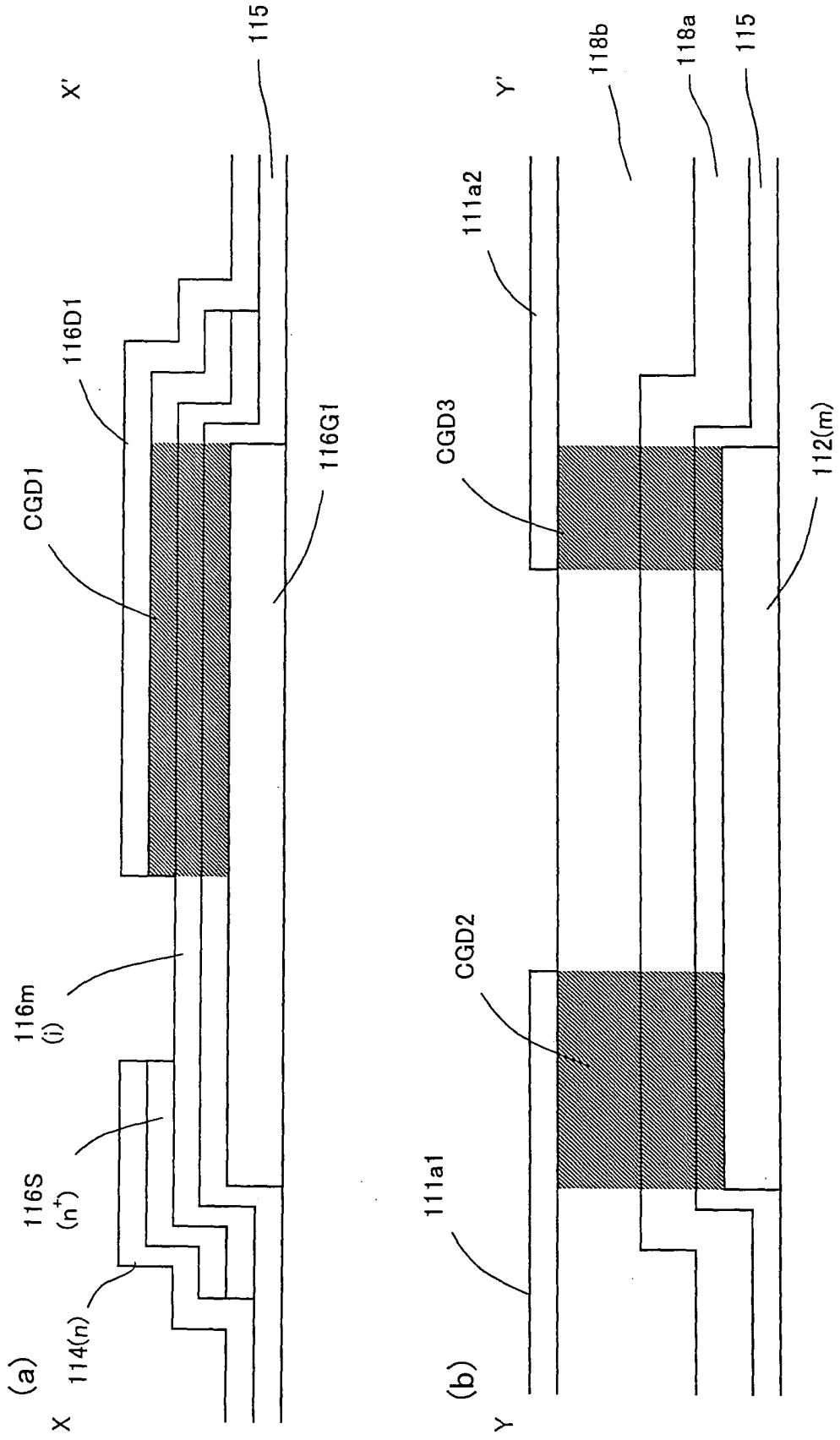

FIG.24

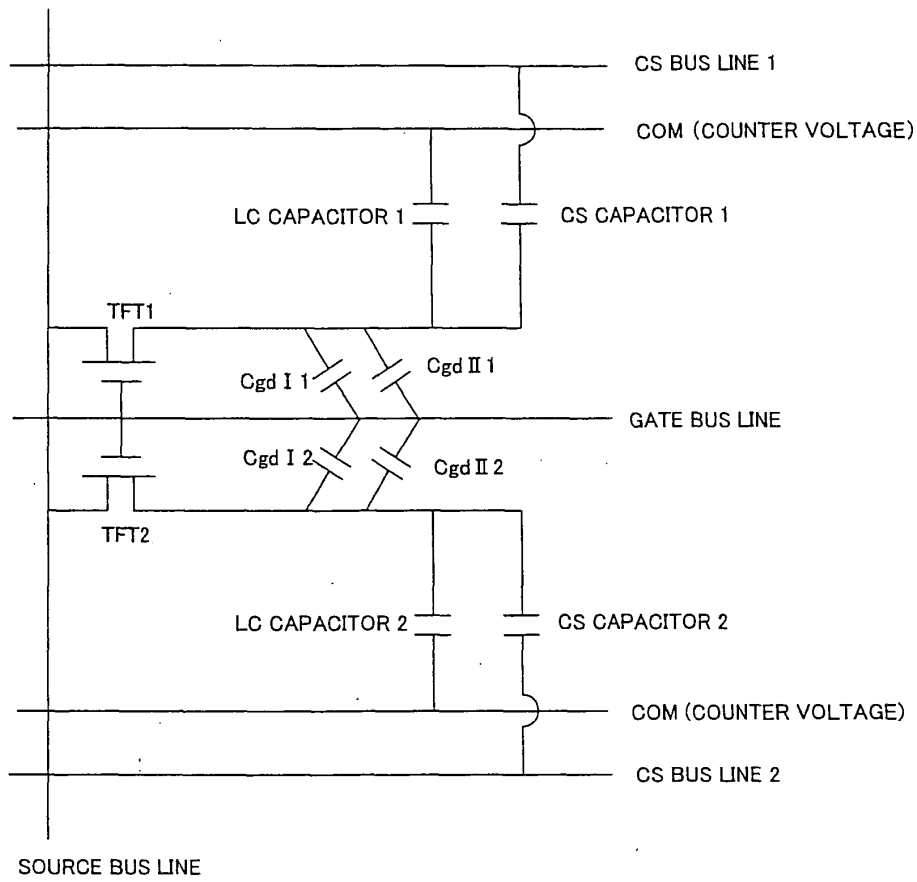

FIG.25

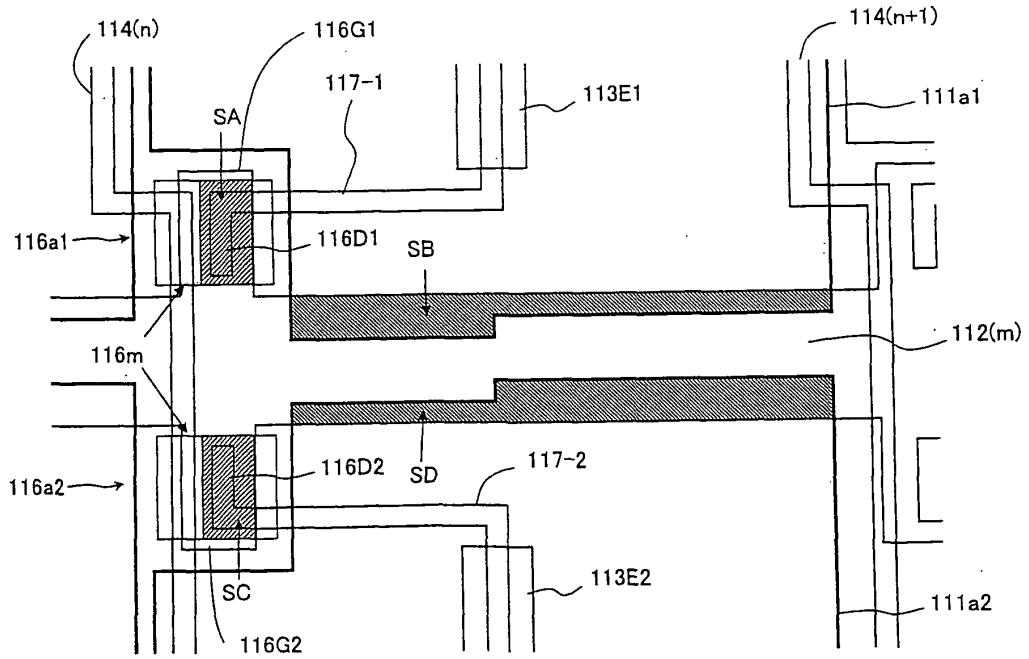

FIG. 26

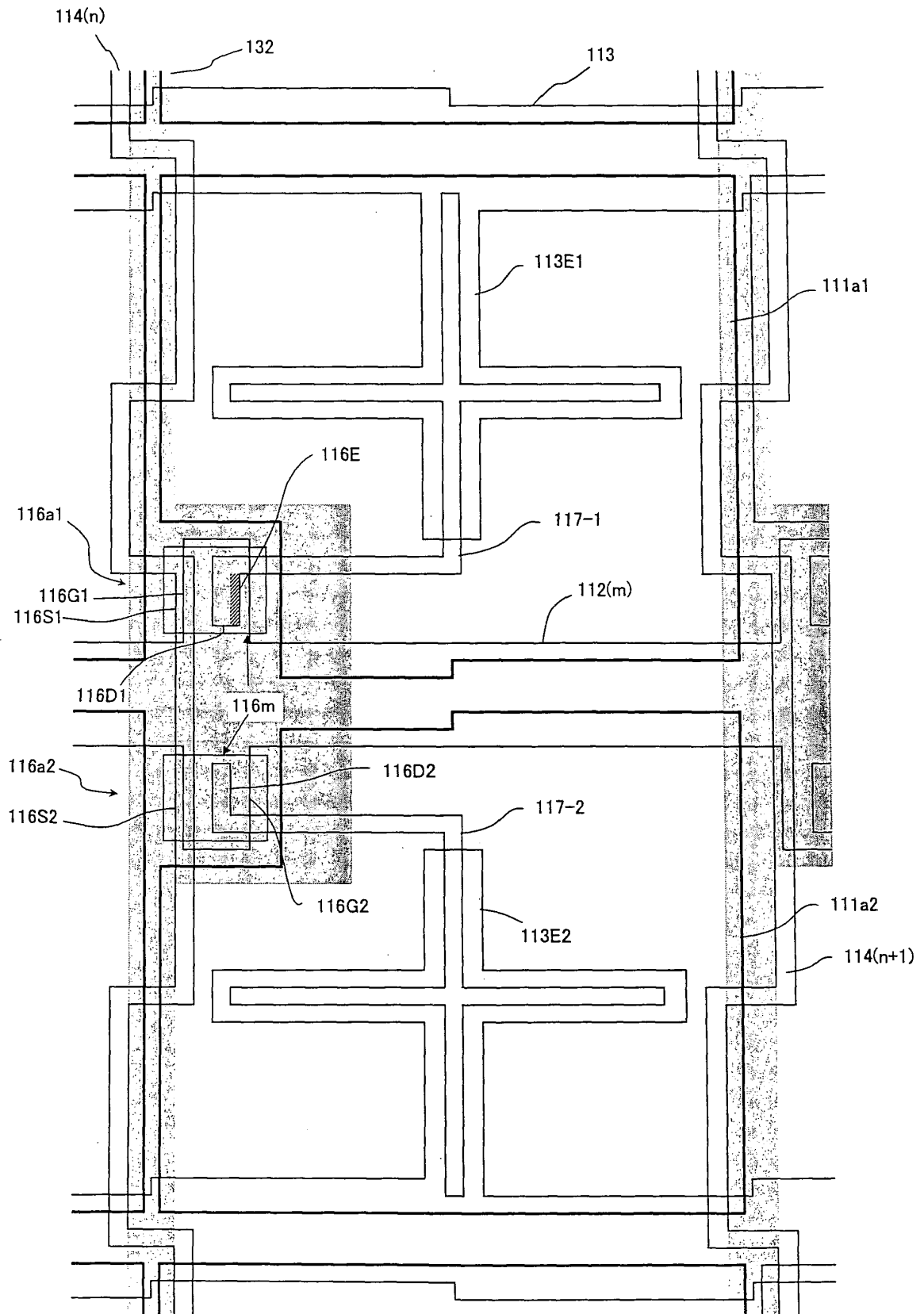

FIG. 27

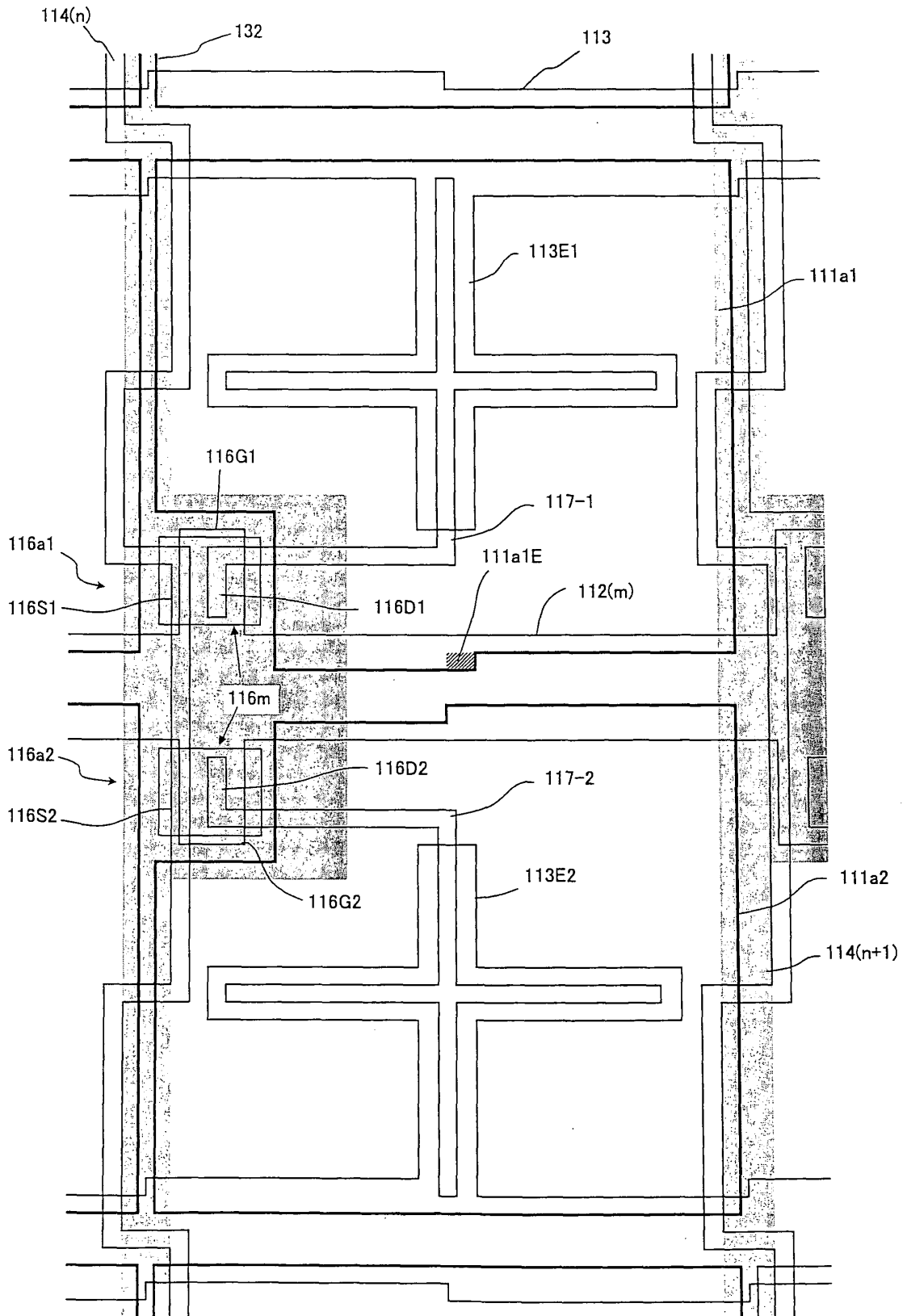
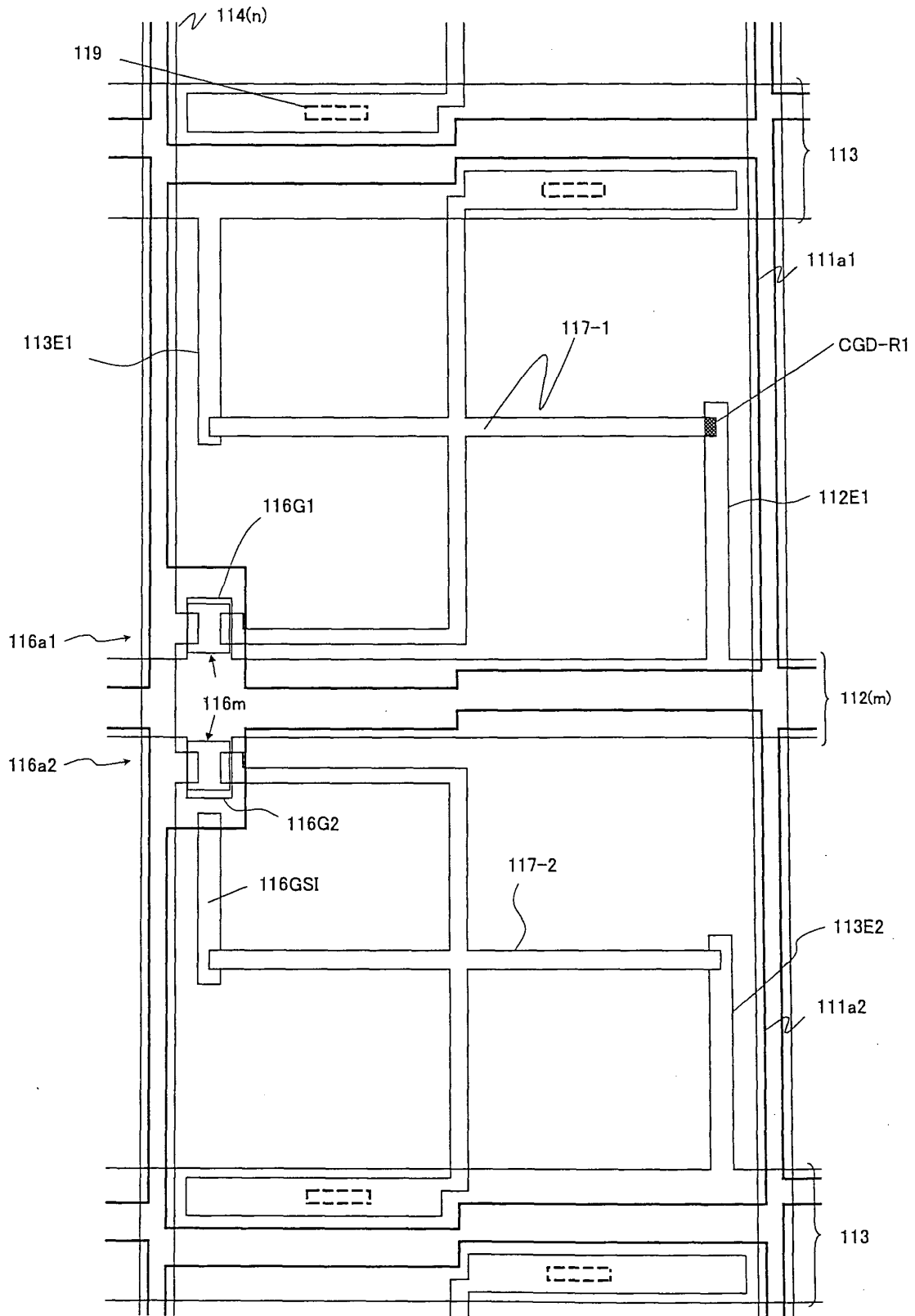

FIG. 28



INTERNATIONAL SEARCH REPORT

International application No.

PCT/JP2007/058881

A. CLASSIFICATION OF SUBJECT MATTER G02F1/1368(2006.01) i, G02F1/1337(2006.01) i		
According to International Patent Classification (IPC) or to both national classification and IPC		
B. FIELDS SEARCHED		
Minimum documentation searched (classification system followed by classification symbols) G02F1/1368, G02F1/1337		
Documentation searched other than minimum documentation to the extent that such documents are included in the fields searched Jitsuyo Shinan Koho 1922-1996 Jitsuyo Shinan Toroku Koho 1996-2007 Kokai Jitsuyo Shinan Koho 1971-2007 Toroku Jitsuyo Shinan Koho 1994-2007		
Electronic data base consulted during the international search (name of data base and, where practicable, search terms used)		
C. DOCUMENTS CONSIDERED TO BE RELEVANT		
Category*	Citation of document, with indication, where appropriate, of the relevant passages	Relevant to claim No.
A	JP 2004-078157 A (Sharp Corp.), 11 March, 2004 (11.03.04), Par. No. [0028]; Fig. 11 & US 2004/0001167 A1 & US 2006/0097972 A1	1-12
A	JP 11-133429 A (Fujitsu Ltd.), 21 May, 1999 (21.05.99), Par. Nos. [0146] to [0153]; Fig. 61 & US 6,512,564 B1	1-12
A	JP 2005-316211 A (Fujitsu Display Technologies Kabushiki Kaisha), 10 November, 2005 (10.11.05), Par. Nos. [0039] to [0043]; Fig. 14 & US 2005/0253797 A1	1-12
<input checked="" type="checkbox"/> Further documents are listed in the continuation of Box C. <input type="checkbox"/> See patent family annex.		
* Special categories of cited documents: "A" document defining the general state of the art which is not considered to be of particular relevance "E" earlier application or patent but published on or after the international filing date "L" document which may throw doubts on priority claim(s) or which is cited to establish the publication date of another citation or other special reason (as specified) "O" document referring to an oral disclosure, use, exhibition or other means "P" document published prior to the international filing date but later than the priority date claimed "T" later document published after the international filing date or priority date and not in conflict with the application but cited to understand the principle or theory underlying the invention "X" document of particular relevance; the claimed invention cannot be considered novel or cannot be considered to involve an inventive step when the document is taken alone "Y" document of particular relevance; the claimed invention cannot be considered to involve an inventive step when the document is combined with one or more other such documents, such combination being obvious to a person skilled in the art "&" document member of the same patent family		
Date of the actual completion of the international search 21 May, 2007 (21.05.07)		Date of mailing of the international search report 05 June, 2007 (05.06.07)
Name and mailing address of the ISA/ Japanese Patent Office		Authorized officer
Facsimile No.		Telephone No.

INTERNATIONAL SEARCH REPORT

International application No.
PCT/JP2007/058881

C (Continuation). DOCUMENTS CONSIDERED TO BE RELEVANT		
Category*	Citation of document, with indication, where appropriate, of the relevant passages	Relevant to claim No.
A	JP 2005-024926 A (Seiko Epson Corp.), 27 January, 2005 (27.01.05), Par. Nos. [0008] to [0018]; Fig. 4 (Family: none)	1-12
A	JP 8-160454 A (Sanyo Electric Co., Ltd.), 21 June, 1996 (21.06.96), Par. No. [0015]; Figs. 1, 3 (Family: none)	1-12
A	JP 8-179341 A (Matsushita Electric Industrial Co., Ltd.), 12 July, 1996 (12.07.96), Fig. 1 (Family: none)	1-12
A	JP 2001-249340 A (Fujitsu Ltd.), 14 September, 2001 (14.09.01), Par. Nos. [0099] to [0112]; Figs. 30 to 31 & US 6,930,739 B2	1-12

Form PCT/ISA/210 (continuation of second sheet) (April 2005)

REFERENCES CITED IN THE DESCRIPTION

This list of references cited by the applicant is for the reader's convenience only. It does not form part of the European patent document. Even though great care has been taken in compiling the references, errors or omissions cannot be excluded and the EPO disclaims all liability in this regard.

Patent documents cited in the description

- JP 11133429 A [0004]
- JP 11352486 A [0004]
- JP 2005141846 A [0072] [0073]
- JP 2004062146 A [0121]

专利名称(译)	液晶显示装置		
公开(公告)号	EP2012179A4	公开(公告)日	2010-04-07
申请号	EP2007742316	申请日	2007-04-24
[标]申请(专利权)人(译)	夏普株式会社		
申请(专利权)人(译)	夏普株式会社		
当前申请(专利权)人(译)	夏普株式会社		
[标]发明人	SHORAKU AKIHIRO TSUBATA TOSHIHIDE		
发明人	SHORAKU, AKIHIRO TSUBATA, TOSHIHIDE		
IPC分类号	G02F1/1368 G02F1/1337		
CPC分类号	G02F1/1393 G02F1/133512 G02F1/133753 G02F1/133788 G02F1/13624 G02F2001/133757 G02F2001/134345		
优先权	2006119419 2006-04-24 JP 2006188645 2006-07-07 JP		
其他公开文献	EP2012179A1 EP2012179B1		
外部链接	Espacenet		

摘要(译)

每个像素区域包括两个子像素区域，其中相对于通过TFT从源极总线提供的信号电压，不同的电压被施加到液晶层。第一基板包括为两个子像素区域提供的第一电极。第二基板包括面对第一电极的第二电极，其中插入有垂直取向液晶层。为这些子像素区域中的每一个提供液晶电容器。每个子像素区域包括至少一个产生暗区域的液晶区域，该暗区域看起来比为位于设备前面的观察者呈现的灰度色调更暗，在第一边缘部分的内部并且基本上平行于第一边缘部分。电极。第一电极的边缘部分的至少一部分布置成与栅极总线重叠并选择性地屏蔽暗区的至少一部分。与两个子像素区域相关联的两个TFT具有基本相等的漏极 - 栅极电容 Cgd，从而提供实现良好显示质量的VA模式液晶显示器件。