



(11) **EP 1 636 636 B1**

(12) **EUROPEAN PATENT SPECIFICATION**

(45) Date of publication and mention of the grant of the patent:
14.01.2009 Bulletin 2009/03

(21) Application number: **04723094.1**

(22) Date of filing: **24.03.2004**

(51) Int Cl.:
G02F 1/1333^(2006.01) G06F 1/16^(2006.01)

(86) International application number:
PCT/KR2004/000638

(87) International publication number:
WO 2004/114000 (29.12.2004 Gazette 2004/53)

(54) **LIQUID CRYSTAL DISPLAY APPARATUS**
FLÜSSIGKRISTALLANZEIGEVORRICHTUNG
APPAREIL D’AFFICHAGE A CRISTAUX LIQUIDES

(84) Designated Contracting States:
FR

(30) Priority: **25.06.2003 KR 2003041330**

(43) Date of publication of application:
22.03.2006 Bulletin 2006/12

(73) Proprietor: **SAMSUNG ELECTRONICS CO., LTD.**
Suwon-si,
Gyeonggi-do 442-742 (KR)

(72) Inventors:
• **LEE, Sang-Duk**
Eumbong-Myeon
Asan-si
Chungcheongnam-do (KR)

• **KANG, Jung-Tae**
Paldal-gu
Suwon-si
Gyeonggi-do 442-736 (KR)

(74) Representative: **Domenego, Bertrand et al**
Cabinet Lavoix
2, place d’Estienne d’Orves
75441 Paris Cedex 09 (FR)

(56) References cited:
JP-A- 8 221 003 **JP-A- 9 043 579**
JP-A- 11 038 430 **JP-A- 2000 155 306**

EP 1 636 636 B1

Note: Within nine months of the publication of the mention of the grant of the European patent in the European Patent Bulletin, any person may give notice to the European Patent Office of opposition to that patent, in accordance with the Implementing Regulations. Notice of opposition shall not be deemed to have been filed until the opposition fee has been paid. (Art. 99(1) European Patent Convention).

Description

Technical Field

[0001] The present invention relates to a liquid crystal display apparatus and a tablet PC having the liquid crystal display apparatus, and more particularly to liquid crystal display apparatus for simplifying a manufacturing process to enhance productivity and a tablet PC having the liquid crystal display apparatus.

Background Art

[0002] Generally, a tablet is a device for a two-dimensional graphic work. A user may write characters and paint on a tablet pad of plate shape by using a pointing device.

[0003] A tablet personal computer (hereinafter, referred to as tablet PC) includes a function of the tablet.

[0004] FIG. 1 is a perspective view showing a tablet PC.

[0005] Referring to FIG. 1, the tablet PC 100 includes a pointing device 110, a liquid crystal display panel 120 and a PC body 130. LCD display panels are known in the art, for example from document JP Pub n°1997-43579 or document JP Pub n°1996-3-221003. A two-dimensional coordinate is inputted via the pointing device 110. An image is displayed via the liquid crystal display panel 120. The PC body 130 includes a digitizer (not shown). The digitizer transforms the two-dimensional coordinate into an electrical signal. A protection glass (not shown) is disposed on the liquid crystal display panel 120 to prevent the liquid crystal display panel 120 from being damaged by the pointing device 110.

[0006] FIG. 2 is a perspective view showing a desktop PC including a tablet PC of FIG. 1.

[0007] Referring to FIGS. 1 and 2, a tablet PC 100 may be combined with a docking stage 200, so that the tablet PC 100 is used as a desktop PC. A wireless or wired keyboard 210 may be connected to the tablet PC 100 and a pointing device 110, so that the tablet PC may receive signals from the keyboard 210 and the pointing device 110.

[0008] FIG. 3 is a cross-sectional view showing a general LCD module used for a tablet PC.

[0009] Referring to FIG. 3, a general liquid crystal display module (hereinafter, referred to as LCD module) includes a liquid crystal display panel 300, a data printed circuit board (hereinafter, referred to as data PCB) 310, a backlight assembly 320, a digitizer 330 and a protection glass 340. The liquid crystal display panel 300 displays an image. The data PCB provides the liquid crystal display panel 300 with image signals. The backlight assembly 320 provides the liquid crystal display panel 300 with a light. The digitizer 330 transforms coordinate information from the pointing device 110 into an electrical signal. The protection glass 340 prevents the liquid crystal display panel from being damaged by the pointing device

110.

[0010] The data PCB 310 is electrically connected to the liquid crystal display panel 300 via a tape carrier package (hereinafter, referred to as TCP) 360 having a data driver chip attached thereon. The TCP 360 is bent, so that the data PCB 310 is disposed on a backside of the backlight assembly 320.

[0011] The digitizer 330 is interposed between the data PCB 310 and the backlight assembly 320.

[0012] In the process of assembling the general LCD module, the general LCD module is disposed upside down. Then, the data PCB 310 is lifted up, and the digitizer 330 is inserted into between the data PCB 310 and the backlight assembly 320.

[0013] Thus, during the data PCB 310 is being lifted up, a channel terminal of the data driver chip 350 formed on the TCP 360 may be damaged and opened.

[0014] Further, a worker should pay attention to details of a process for assembling the general LCD module, so that a time spent for manufacturing the tablet PC increases. Thus, productivity is lowered.

Disclosure of Invention

25 Technical Problem

[0015] Accordingly, the present invention is provided to substantially obviate one or more problems due to limitations and disadvantages of the related art.

[0016] In one aspect of the present invention, a liquid crystal display apparatus for enhancing productivity is provided.

[0017] In an embodiment of the present invention, a tablet PC having the liquid crystal display apparatus is provided.

Technical Solution

[0018] A liquid crystal display apparatus includes a liquid crystal display panel, a driver printed circuit board, a digitizer, a backlight assembly and a receiving container. The liquid crystal display panel receives image data, and displays an image according to the image data. The driver printed circuit board is electrically connected to the liquid crystal display panel so as to provide the liquid crystal display panel with the image data. The digitizer provides the driver printed circuit board with signals corresponding to coordinate information. The backlight assembly is disposed under the liquid crystal display panel so as to provide the liquid crystal display panel with a light. The receiving container has a front side and a back side. The front side supports the backlight assembly. First and second protrusion portions are formed on the backside so as to support the driver printed circuit board, such that the driver printed circuit board is spaced apart from the backside of the receiving container to form an insertion space that extends from the first protrusion portion to the second protrusion portion, the insertion space being con-

figured to facilitate insertion of the digitizer between the driver printed circuit board and the receiving container.

[0019] The tablet personal computer includes the liquid crystal display apparatus and a chassis that receives the liquid crystal display panel and the backlight assembly.

[0020] Thus, a work for lifting up the data PCB so as to insert the digitizer into between the data PCB and the receiving container is not required, thereby enhancing productivity.

Description of Drawings

[0021] The above and other features and advantage points of the present invention will become more apparent by describing in detail exemplary embodiments thereof with reference to the accompanying drawings, in which:

[0022] FIG. 1 is a perspective view showing a tablet PC;

[0023] FIG. 2 is a perspective view showing a desktop PC including a tablet PC of FIG. 1;

[0024] FIG. 3 is a cross-sectional view showing a general LCD module used for a tablet PC;

[0025] FIG. 4 is an exploded perspective view showing a liquid crystal display apparatus according to a first exemplary embodiment of the present invention;

[0026] FIG. 5 is a plan view showing a backside of a backlight assembly of FIG. 4;

[0027] FIG. 6 is a cross-sectional view taken along the line A-A' of FIG. 5;

[0028] FIG. 7 is a cross-sectional view taken along a line B-B' of FIG. 5;

[0029] FIG. 8 is a perspective view showing an insertion of a digitizer into a mold frame and a data PCB;

[0030] FIG. 9 is a plan view showing a backside of a backlight assembly of a liquid crystal display apparatus according to a second exemplary embodiment of the present invention;

[0031] FIG. 10 is a cross-sectional view taken along the line C-C' of FIG. 9; and

[0032] FIG. 11 is a plan view showing another digitizer being inserted into an insertion space of FIG. 9.

Best Mode

[0033] Hereinafter, the preferred embodiment of the present invention will be described in detail with reference to the accompanied drawings.

[0034] Embodiment 1

[0035] FIG. 4 is an exploded perspective view showing a liquid crystal display apparatus according to a first exemplary embodiment of the present invention, and FIG. 5 is a plan view showing a backside of a backlight assembly of FIG. 4. FIG. 6 is a cross-sectional view taken along the line A-A' of FIG. 5, and FIG. 7 is a cross-sectional view taken along a line B-B' of FIG. 5.

[0036] Referring to FIG. 4, a liquid crystal display ap-

paratus 400 according to a first exemplary embodiment of the present invention includes a display assembly 500 and a backlight assembly 600. The display assembly 500 displays an image. The backlight assembly 600 provides the display assembly 500 with a light.

[0037] The display assembly 500 includes a liquid crystal display panel 510, a gate printed circuit board (hereinafter, referred to as gate PCB) 520, a data printed circuit board (hereinafter, referred to as data PCB) 530, a gate tape carrier package (hereinafter, referred to as gate TCP) 540 and a data tape carrier package (hereinafter, referred to as data TCP) 550. The liquid crystal display panel 510 displays an image. The gate PCB 520 provides the liquid crystal display panel 510 with driving signals. The data PCB 530 provides the liquid crystal display panel 510 with image data signals. The gate TCP 540 electrically connects the gate PCB 520 to the liquid crystal display panel 510. The data TCP 550 electrically connects the data PCB 530 to the liquid crystal display panel 510.

[0038] The liquid crystal display panel 510 includes a thin film transistor substrate (hereinafter, referred to as TFT substrate) 512, a color filter substrate 514 and a liquid crystal layer (not shown). The TFT substrate 512 includes a thin film transistor (not shown) and a pixel electrode (not shown). The color filter substrate 514 includes a color filter (not shown) and a common electrode (not shown). The color filter substrate 514 faces the TFT substrate 512. The liquid crystal layer is interposed between the TFT substrate 512 and the color filter substrate 514.

[0039] A plurality of data lines (not shown) and a plurality of gate lines (not shown) are formed on the TFT substrate 512. The data lines are extended in a first direction. The gate lines are extended in a second direction that is substantially perpendicular to the first direction. In addition, the TFT substrate 512 includes a plurality of pixel electrodes arranged in a matrix shape. The thin film transistor includes a gate electrode, a drain electrode and a source electrode. The gate electrode is electrically connected to one of the gate lines. The source electrode is electrically connected to one of the data lines. The drain electrode is electrically connected to one of the pixel electrodes.

[0040] The gate lines are electrically connected to the gate TCP 540 having a gate driver chip 560. The data lines are electrically connected to the data TCP 550 having a data driver chip 570.

[0041] The data TCP 550 is electrically connected to the data PCB 530, so that the data PCB applies an image data signal to the data lines via the data TCP 550 at the right time. The gate TCP 540 is electrically connected to the gate PCB 520, so that the gate PCB 520 applies a gate driving signal to the gate lines via the gate TCP 540.

[0042] A protection glass 580 is disposed on the liquid crystal display panel 510 to protect the liquid crystal display panel 510. The protection glass 580 prevents the liquid crystal display panel 510 from being damaged by

an input pen (not shown).

[0043] The backlight assembly 600 includes a light generating section 610 and a light guide plate 620. The light generating section 610 generates a light. The light guide plate 620 guides the light generated from the light generating section 610 toward the liquid crystal display panel 510. The light generating section 610 includes a lamp 612 and a lamp reflector 614. The lamp reflector 614 covers the lamp 612 to reflect a light generated from the lamp 612 toward the light guide plate 620.

[0044] The back light assembly 600 further includes a reflection plate 630 and optical sheets 640. The reflection plate 630 is disposed under the light guide plate 620 to reflect a light that is leaked from the light guide plate 620 toward the light guide plate 620. The optical sheets 640 are disposed over the light guide plate 620 to uniformize a luminance of a light emitted from the light guide plate 620.

[0045] A mold frame (or receiving container) 700 receives the display assembly 500 and the backlight assembly 600.

[0046] The mold frame 700 receives the reflection plate 630, the light guide plate 620 and the optical sheets 640 in sequence. Then, the mold frame 700 receives the liquid crystal display panel 510, such that the liquid crystal display panel 510 is disposed over the optical sheets 640.

[0047] A chassis 800 is combined with the mold frame 700 to fix the display assembly 500 and the backlight assembly 600.

[0048] A digitizer 900 is disposed under the mold frame 700. The digitizer 600 transforms coordinate information from the input pen into an electrical signal. Then, the electrical signal is transferred to a tablet PC body (not shown). The tablet PC body receives the electrical signal corresponding to an image data. The tablet PC provides the data PCB 530 with the electrical signal to apply the electrical signal to data lines.

[0049] The data TCP 550 is bent, such that the data PCB 530 of the display assembly 500 is disposed on a backside of the mold frame 700.

[0050] Referring to FIG. 5, the data PCB 530 includes first and second connection portions 532 and 534. The first and second connection portions 532 and 534 protrude from each end of the data PCB 530. The first and second connection portions 532 and 534 include first and second connection holes 536 and 538 respectively. First and second bolts 650 and 660 penetrate the first and second connection holes 536 and 538 respectively, and fix the data PCB 530 to the mold frame 700.

[0051] The mold frame 700 includes third and fourth connection portions 710 and 720. The third and fourth connection portions 710 and 720 correspond to the first and second connection portions 532 and 534 respectively.

[0052] Referring to FIGS. 6 and 7, the mold frame 700 includes the third and fourth connection portions 710 and 720. The third connection portion 710 protrudes from a first end portion of the mold frame 700, such that the third

connection portion 710 corresponds to the first connection portion 532. The fourth connection portion 720 protrudes from a second end portion of the mold frame 700, such that the fourth connection portion 720 corresponds to the second connection portion 534.

[0053] The third connection portion 710 includes a first protrusion 730 that protrudes upwardly from the third connection portion 710. The fourth connection portion 720 includes a second protrusion 740 that protrudes upwardly from the fourth connection portion 720. The first protrusion 730 is substantially same as the second protrusion 740 in height.

[0054] The first protrusion 730 includes a first connection groove 732 that corresponds to the first connection hole 536 of the data PCB 530. The second protrusion 740 includes a second connection groove 742 that corresponds to the second connection hole 538 of the data PCB 530.

[0055] The data PCB 530 and the mold frame 700 may be combined together by Front Mount method. That is, the first and second bolts 650 and 660 pass through the first and second connection holes 536 and 538 of the data PCB 530, and inserted into the first and second connection grooves 732 and 734 of the mold frame 700, so that the data PCB 530 is fixed at a backside of the mold frame 700.

[0056] Then, an insertion space 750 is formed between the data PCB 530 and the mold frame 700 due to the first and second protrusions 730 and 740. The digitizer 900 of FIG. 4 is inserted into the insertion space 750.

[0057] FIG. 8 is a perspective view showing an insertion of a digitizer into a mold frame and a data PCB.

[0058] Referring to FIGS. 4 and 8, a digitizer 900 is inserted into an insertion space formed between the data PCB 530 and the mold frame 700 in a second direction D2, so that the digitizer 900 is interposed between the data PCB 530 and the mold frame 700.

[0059] Thus, a worker does not need to lift up the data PCB 530 to insert the digitizer 900, when assembling an LCD module. As a result, channel terminals of a data driver chip 570 formed on the data TCP 550 are not opened.

[0060] According to the present embodiment, a width Wd2 of the digitizer 900 is substantially same as a width Wd1 of the liquid crystal display apparatus 400. That is, the digitizer 900 and the liquid crystal display apparatus 400 have a substantially same width in a first direction D1 that is substantially perpendicular to the second direction D2.

[0061] Thus, first and second connection portions 532 and 534 of the data PCB 530, and third and fourth connection portions 710 and 720 of the mold frame 700 are formed. The first and third connection portions 532 and 710 protrude from one side, and the second and fourth connection portions 534 and 720 protrude from the other side, so that the insertion space for receiving the digitizer 900 having same width as the liquid crystal display apparatus 400 is formed.

[0062] Embodiment 2

[0063] FIG. 9 is a plan view showing a backside of a backlight assembly of a liquid crystal display apparatus according to a second exemplary embodiment of the present invention, and FIG. 10 is a cross-sectional view taken along the line C-C' of FIG. 9. The liquid crystal display apparatus is same as in Embodiment 1 except for a backlight assembly. Thus, the same reference numerals will be used to refer to the same or like parts as those described in Embodiment 1 and any further explanation will be omitted.

[0064] Referring to FIG. 9, a liquid crystal display device according to a second exemplary embodiment of the present invention includes a data PCB 1100 disposed under a backside of a mold frame 1000. A data TCP 550 is bent, so that the data PCB 1100 is disposed under the mold frame 1000. A width Wd2 of the data PCB 1100 and the digitizer 1200 is shorter than a width Wd1 of the mold frame 1000. The digitizer 1200 is inserted between the data PCB 1100 and the mold frame 1000.

[0065] The data PCB 1100 includes first and second connection portions 1110 and 1120 protruded from both ends of the data PCB 1100 respectively. The first and second connection portions 1110 and 1120 include first and second connection holes 1130 and 1140 to which first and second bolts 1300 and 1400 penetrate, respectively.

[0066] Additionally, the data PCB 1100 is combined with the mold frame 1000.

[0067] Referring to FIG. 10, the mold frame 1000 includes first and second protrusions 1010 and 1020. The first and second protrusions 1010 and 1020 correspond to the first and second connection portions 1110 and 1120 of the data PCB 1100 respectively. The first and second protrusions 1010 and 1020 include first and second connection grooves 1030 and 1040 respectively. The first and second connection grooves 1030 and 1040 correspond to the first and second connection holes 1130 and 1140 respectively.

[0068] The data PCB 1100 and the mold frame 1000 may be combined together by Front Mount method. That is, the first and second bolts 1300 and 1400 pass through the first and second connection holes 1130 and 1140 of the data PCB 1100, and are inserted into the first and second connection grooves 1030 and 1040 of the mold frame 1000, so that the data PCB 1100 is fixed at a backside of the mold frame 1000.

[0069] Then, an insertion space 1050 is formed between the data PCB 1100 and the mold frame 1000 due to the first and second protrusions 1010 and 1020.

[0070] A width of the insertion space 1050 is shorter than the width Wd1 of the mold frame 1000. That is, when widths W1 of the first and second connection portions 1110 and 1120 are subtracted from the width Wd1 of the insertion space 1050, the width of the insertion space 1050 is obtained.

[0071] FIG. 11 is a plan view showing another digitizer being inserted into an insertion space of FIG. 9.

[0072] Referring to FIGS. 10 and 11, a digitizer 1500 is chamfered. That is, corners that correspond to the first and second protrusions 1010 and 1020 are cut out. In detail, the corners are cut out as much as a depth W1 of the first and second edges 1502 and 1504 respectively, such that the digitizer 1500 may be inserted into the insertion space 1050.

[0073] Hereinbefore, a liquid crystal display apparatus having the data driver chip 570 formed on the data TCP 550 is explained.

[0074] Further, the structure of the liquid crystal display apparatus according to the present invention is applied to a touch screen type tablet PC having a tablet panel that receives position coordinates from an input pen and transfers the position coordinates to a digitizer.

[0075] As described above, an insertion space for receiving the digitizer is formed between the data PCB that is disposed under the mold frame and mold frame. That is, the first and second connection portions protruding at each end of the mold frame and having the first and second protrusions respectively, so that the insertion space is formed.

[0076] Then, the digitizer is inserted into the insertion space. Thus, a work for lifting up the data PCB to insert the digitizer into between the data PCB and mold frame is not required.

[0077] As a result, terminals of the data driver chip formed on the TCP are not opened, which frequently occurs when the data PCB is lifted up. Further, productivity is enhanced because of simplicity of work.

Claims

1. A liquid crystal display apparatus (400) comprising:

- a liquid crystal display panel (510) that receives image data and displays an image according to the image data;
- a driver printed circuit board (530; 1100) that is electrically connected to the liquid crystal display panel (510) to provide the liquid crystal display panel (510) with the image data;
- a digitizer (900; 1200) that provides the driver printed circuit board (530; 1100) with signals corresponding to coordinate information;
- a backlight assembly (600) disposed under the liquid crystal display panel (510) to provide the liquid crystal display panel (510) with a light; and
- a receiving container (700; 1000) having a front side and a back side, the front side supporting the backlight assembly (600),

characterized in that

- first and second protrusion portions (730, 740; 1010, 1020) are formed on the back side of the receiving container (700; 1000) to support the

- driver printed circuit board (530; 1100), such that the driver printed circuit board (530; 1100) is spaced apart from the back side of the receiving container (700; 1000) to form an insertion space (750; 1050) that extends from the first protrusion portion (730; 1010) to the second protrusion portion (740; 1020), the insertion space (750; 1050) being configured to facilitate insertion of the digitizer (900; 1200) between the driver printed circuit board (530; 1100) and the receiving container (700; 1000).
2. The liquid crystal display apparatus (400) of claim 1, wherein the receiving container (700) includes first and second connection portions (710; 720) protruding from end portions of the receiving container (700), such that a width of the end portion of the receiving container (700) is larger than a width of the receiving container (700), the first and second protrusion portions (730; 740) protrude from the first and second connection portions (710; 720) respectively, and the first and second protrusion portions (730; 740) include first and second connection holes (732; 742) respectively.
 3. The liquid crystal display apparatus (400) of claim 2, wherein the driver printed circuit board (530) includes third and fourth connection portions (532; 534) corresponding to the first and second connection portions (710; 720) of the receiving container (700), the third and fourth connection portions (532; 534) have third and fourth connection holes (536; 538) respectively, and the third and fourth connection holes (536; 538) correspond to the first and second connection holes (732; 742) respectively.
 4. The liquid crystal apparatus of claim 3, wherein a first bolt (650) penetrates the first connection hole (732) and the third connection hole (536), and a second bolt (660) penetrates the second connection hole (742) and the fourth connection hole (538), so that the driver printed circuit board (530) and the receiving container (700) are combined together, such that the driver printed circuit board and the receiving container (700) are spaced apart from each other.
 5. The liquid crystal display apparatus (400) of claim 1, wherein the first and second protrusion portions (1010; 1020) are disposed on the edge portion of the receiving container (1000), and the first and second protrusion portions (1010, 1020) have first and second connection holes (1030; 1040).
 6. The liquid crystal display apparatus (400) of claim 5, wherein the driver printed circuit board (1100) includes third and fourth connection holes (1130, 1140) corresponding to the first and second connection holes (1030, 1040), respectively.
 7. The liquid crystal display apparatus (400) of claim 6, wherein a first bolt (1300) penetrates the first connection hole (1030) and the third connection hole (1130) and a second bolt (1400) penetrates the second connection hole (1040) and the fourth connection hole (1140) to combine the driver printed circuit board (1100) and the receiving container (1000), such that the driver printed circuit board (1100) and the receiving container (1000) are spaced apart from each other.
 8. The liquid crystal display apparatus (400) according to any one of the preceding claims, wherein the digitizer (900; 1200) is chamfered to be disposed between the driver printed circuit board (530; 1100) and the receiving container (700; 1000).
 9. A tablet personal computer **characterized in that** it includes the liquid crystal display apparatus according to any one of the claims 1 to 8, and a chassis (800) that receives the liquid crystal display panel (510) and the backlight assembly (600).

25 Patentansprüche

1. Flüssigkristallanzeigevorrichtung (400), enthaltend:

- ein Flüssigkristallanzeigepaneel (510), das Bilddaten empfängt und ein Bild gemäß der Bilddaten anzeigt;
 - eine gedruckte Treiberschaltungskarte (530; 1100), die mit dem Flüssigkristallanzeigepaneel (510) verbunden ist, um das Flüssigkristallanzeigepaneel (510) mit den Bilddaten zu versorgen;
 - einen Digitalisierer (900; 1200), der die gedruckte Treiberschaltungskarte (530; 1100) mit Signalen entsprechend Koordinateninformationen versorgt;
 - eine Hintergrundbeleuchtungsanordnung (600), die unter dem Flüssigkristallanzeigepaneel (510) angeordnet ist, um das Flüssigkristallanzeigepaneel (510) mit Licht zu versorgen; und
- ein Aufnahmegehäuse (700; 1000), das eine Vorderseite und eine Rückseite hat, wobei die Vorderseite die Hintergrundbeleuchtungsanordnung (600) trägt,

dadurch gekennzeichnet, dass

erste und zweite Vorsprungsabschnitte (730, 740; 1010, 1020) auf der Rückseite des Aufnahmegehäuses (700; 1000) ausgebildet sind, um die gedruckte Treiberschaltungskarte (530; 1100) derart zu halten, dass die gedruckte Treiberschaltungskarte (530; 1100) von der Rückseite des Aufnahmegehäuses (700; 1000) beabstandet ist, um einen Einfügeraum

- (750; 1050) auszubilden, der sich vom ersten Vorsprungsabschnitt (730; 1010) zum zweiten Vorsprungsabschnitt (740; 1020) erstreckt, wobei der Einfügeraum (750; 1050) so beschaffen ist, dass er das Einfügen des Digitalisierers (9000; 1200) zwischen die gedruckte Treiberschaltungskarte (530; 1100) und das Aufnahmegehäuse gestattet.
2. Flüssigkristallanzeigevorrichtung (400) nach Anspruch 1, bei der das Aufnahmegehäuse (700) einen ersten und einen zweiten Verbindungsabschnitt (710; 720) enthält, die von Endabschnitten des Aufnahmegehäuses (700) derart hervorragen, dass eine Breite des Endabschnittes des Aufnahmegehäuses (700) größer ist als eine Breite des Aufnahmegehäuses, der erste und der zweite Vorsprungsabschnitt (730; 740) vom ersten bzw. zweiten Verbindungsabschnitt (710; 720) hervorragen und der erste sowie der zweite Vorsprungsabschnitt (730; 740) ein erstes bzw. ein zweites Verbindungsloch (732; 742) enthalten.
 3. Flüssigkristallanzeigevorrichtung (400) nach Anspruch 2, bei dem die gedruckte Treiberschaltungskarte (530) einen dritten und einen vierten Verbindungsabschnitt (532; 534) entsprechend dem ersten und dem zweiten Verbindungsabschnitt (710; 720) des Aufnahmegehäuses (700) enthält, der dritte sowie der vierte Verbindungsabschnitt (532; 534) ein drittes bzw. ein viertes Verbindungsloch (536; 538) haben und das dritte und vierte Verbindungsloch (536; 538) dem ersten bzw. dem zweiten Verbindungsloch (732; 742) entsprechen.
 4. Flüssigkristallanzeigevorrichtung nach Anspruch 3, bei dem eine erste Schraube (650) das erste Verbindungsloch (732) und das zweite Verbindungsloch (536) durchdringt und eine zweite Schraube (660) das zweite Verbindungsloch (742) und das vierte Verbindungsloch (538) durchdringt, so dass die gedruckte Treiberschaltungskarte (530) und das Aufnahmegehäuse (700) miteinander derart kombiniert sind, dass die gedruckte Treiberschaltungskarte und das Aufnahmegehäuse (700) voneinander beabstandet sind.
 5. Flüssigkristallanzeigevorrichtung (400) nach Anspruch 1, bei dem der erste und der zweite Vorsprung (1010; 1020) am Randabschnitt des Aufnahmegehäuses (1000) angeordnet sind und der erste sowie der zweite Vorsprungsabschnitt (1010, 1020) ein erstes und ein zweites Verbindungsloch (1030; 1040) haben.
 6. Flüssigkristallanzeigevorrichtung (400) nach Anspruch 5, bei der die gedruckte Treiberschaltungskarte (1100) ein drittes und ein viertes Verbindungsloch (1130, 1140) entsprechend dem ersten bzw.
- dem zweiten Verbindungsloch (1030, 1040) enthält.
7. Flüssigkristallanzeigevorrichtung (400) nach Anspruch 5, bei der eine erste Schraube (1300) das erste Verbindungsloch (1030) und das dritte Verbindungsloch (1130) durchdringt und eine zweite Schraube (1400) das zweite Verbindungsloch (1040) und das vierte Verbindungsloch (1140) durchdringt, um die gedruckte Treiberschaltungskarte (1100) und das Aufnahmegehäuse (1000) zu kombinieren, so dass die gedruckte Treiberschaltungskarte (1100) und das Aufnahmegehäuse (1000) voneinander beabstandet sind.
 8. Flüssigkristallanzeigevorrichtung (400) nach einem der vorhergehenden Ansprüche, bei der der Digitalisierer (900; 1200) abgeschrägt ist, um zwischen der gedruckten Treiberschaltungskarte (530; 1100) und dem Aufnahmegehäuse (700; 1000) angeordnet zu werden.
 9. Tablet-PC, **dadurch gekennzeichnet, dass** er die Flüssigkristallanzeigevorrichtung gemäß einem der Ansprüche 1 bis 8 und ein Gehäuse (800) enthält, das das Flüssigkristallanzeigepaneel (510) und die Hintergrundbeleuchtungsanordnung (600) aufnimmt.
- ### 30 Revendications
1. Appareil d'affichage à cristaux liquides (400) comprenant :
 - un écran d'affichage à cristaux liquides (510) qui reçoit des données d'image et affiche une image en fonction des données d'image ;
 - une carte de circuits imprimés de commande (530; 1100) qui est électriquement connectée à l'écran d'affichage à cristaux liquides (510) pour fournir les données d'image à l'écran d'affichage à cristaux liquides (510) ;
 - un numériseur (900 ; 1200) qui fournit à la carte de circuits imprimés de commande (530; 1100) des signaux correspondant à des informations de coordonnées ;
 - un ensemble de rétroéclairage (600) disposé sous l'écran d'affichage à cristaux liquides (510) pour fournir une lumière à l'écran d'affichage à cristaux liquides (510) ; et
 - un conteneur de réception (700 ; 1000) ayant une face avant et une face arrière, le côté avant supportant l'ensemble de rétroéclairage (600),
- caractérisé en ce que**
- des première et deuxième portions faisant saillie (730, 740 ; 1010, 1020) sont formées sur

- le côté arrière du conteneur de réception (700 ; 1000) pour supporter la carte de circuits imprimés de commande (530 ; 1100), de sorte que la carte de circuits imprimés de commande (530 ; 1100) est espacée de la face arrière du conteneur de réception (700 ; 1000) pour former un espace d'insertion (750 ; 1050) qui s'étend de la première portion faisant saillie (730 ; 1010) à la deuxième portion faisant saillie (740 ; 1020), l'espace d'insertion (750 ; 1050) étant configuré pour faciliter l'insertion du numériseur (900 ; 1200) entre la carte de circuits imprimés de commande (530 ; 1100) et le conteneur de réception (700 ; 1000).
2. Appareil d'affichage à cristaux liquides (400) selon la revendication 1, dans lequel le conteneur de réception (700) comprend des première et deuxième portions de connexion (710 ; 720) faisant saillie par rapport aux portions d'extrémité du conteneur de réception (700), de sorte qu'une largeur de la portion d'extrémité du conteneur de réception (700) soit supérieure à une largeur du conteneur de réception (700), les première et deuxième portions faisant saillie (730 ; 740) faisant saillie par rapport aux première et deuxième portions de connexion (710 ; 720) respectivement, et les première et deuxième portions faisant saillie (730 ; 740) comprennent des premier et deuxième trous de connexion (732 ; 742) respectivement.
 3. Appareil d'affichage à cristaux liquides (400) selon la revendication 2, dans lequel la carte de circuits imprimés de commande (530) comprend des troisième et quatrième portions de connexion (532 ; 534) correspondant aux première et deuxième portions de connexion (710 ; 720) du conteneur de réception (700), les troisième et quatrième portions de connexion (532 ; 534) ont des troisième et quatrième trous de connexion (536, 538) respectivement, et les troisième et quatrième trous de connexion (536 ; 538) correspondent aux premier et deuxième trous de connexion (732 ; 742) respectivement.
 4. Appareil d'affichage à cristaux liquides selon la revendication 3, dans lequel un premier boulon (650) pénètre dans le premier trou de connexion (732) et le troisième trou de connexion (536), et un deuxième boulon (660) pénètre dans le deuxième trou de connexion (742) et le quatrième trou de connexion (538), de sorte que la carte de circuits imprimés de commande (530) et le conteneur de réception (700) soient combinés ensemble de manière à ce que la carte de circuits imprimés de commande et le conteneur de réception (700) soient espacés l'un de l'autre.
 5. Appareil d'affichage à cristaux liquides (400) selon la revendication 1, dans lequel les première et deuxième portions faisant saillie (1010 ; 1020) sont disposées sur la portion de bord du conteneur de réception (1000), et les première et deuxième portions faisant saillie (1010, 1020) ont des premier et deuxième trous de connexion (1030 ; 1040).
 6. Appareil d'affichage à cristaux liquides (400) selon la revendication 5, dans lequel la carte de circuits imprimés de commande (1100) comprend des troisième et quatrième trous de connexion (1130, 1140) correspondant aux premier et deuxième trous de connexion (1030, 1040) respectivement.
 7. Appareil d'affichage à cristaux liquides (400) selon la revendication 6, dans lequel un premier boulon (1300) pénètre dans le premier trou de connexion (1030) et le troisième trou de connexion (1130) et un deuxième boulon (1400) pénètre dans le deuxième trou de connexion (1040) et le quatrième trou de connexion (1140) pour combiner la carte de circuits imprimés de commande (1100) et le conteneur de réception (1000), de sorte que la carte de circuits imprimés de commande (1100) et le conteneur de réception (1000) soient espacés l'un de l'autre.
 8. Appareil d'affichage à cristaux liquides (400) selon l'une quelconque des revendications précédentes, dans lequel le numériseur (900 ; 1200) est biseauté pour être disposé entre la carte de circuits imprimés de commande (530 ; 1100) et le conteneur de réception (700 ; 1000).
 9. Ordinateur personnel tablette **caractérisé en ce qu'il** comprend l'appareil d'affichage à cristaux liquides selon l'une quelconque des revendications 1 à 8, et un châssis (800) qui reçoit l'écran d'affichage à cristaux liquides (510) et l'ensemble de rétroéclairage (600).

[Fig. 1]

100

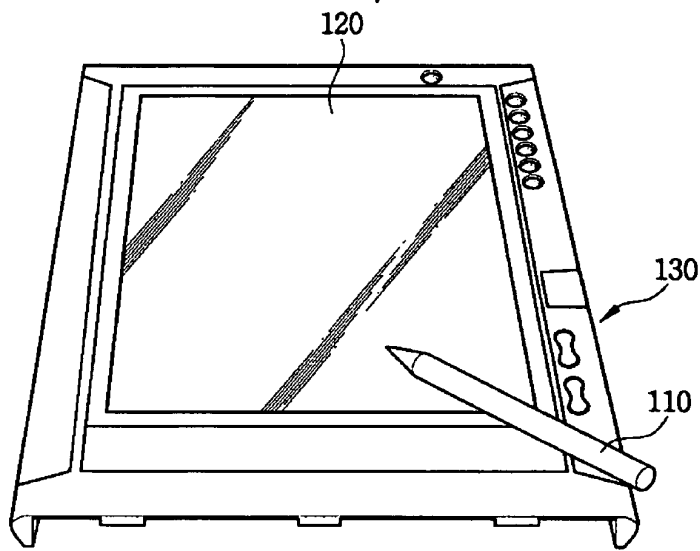

[Fig. 2]

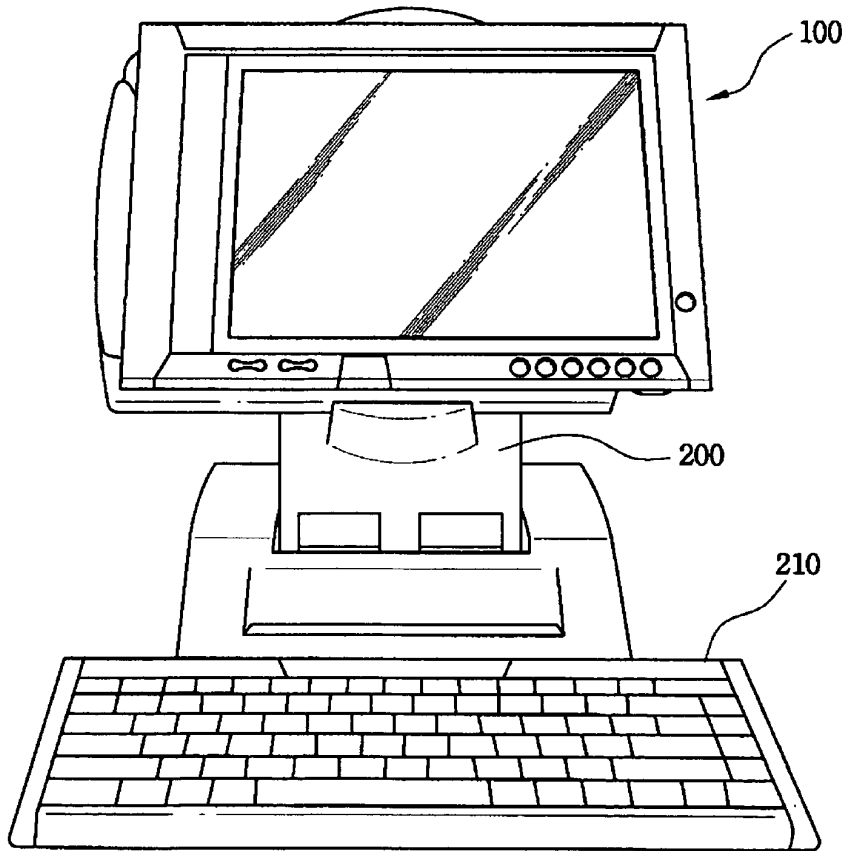

[Fig. 3]

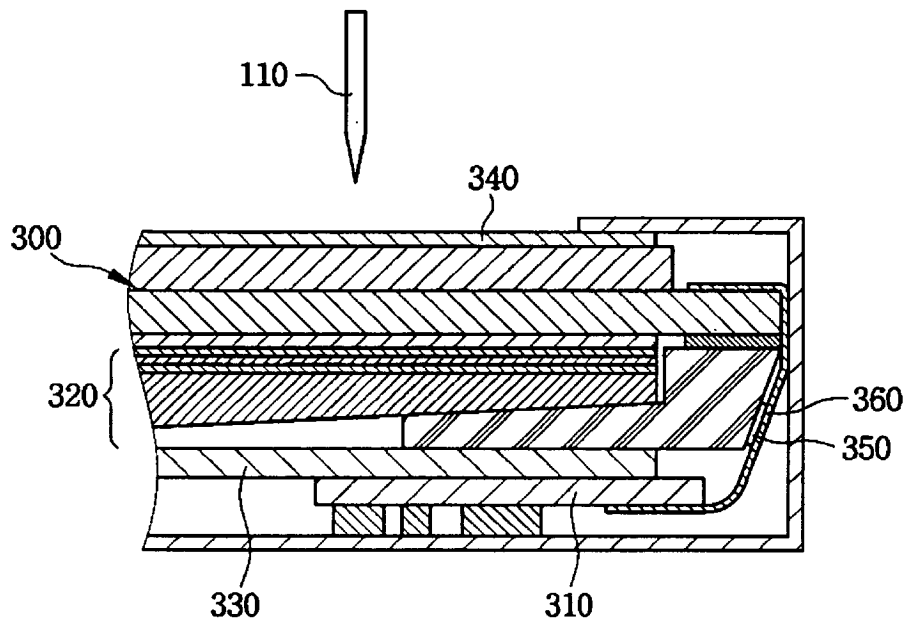

[Fig. 4]

400

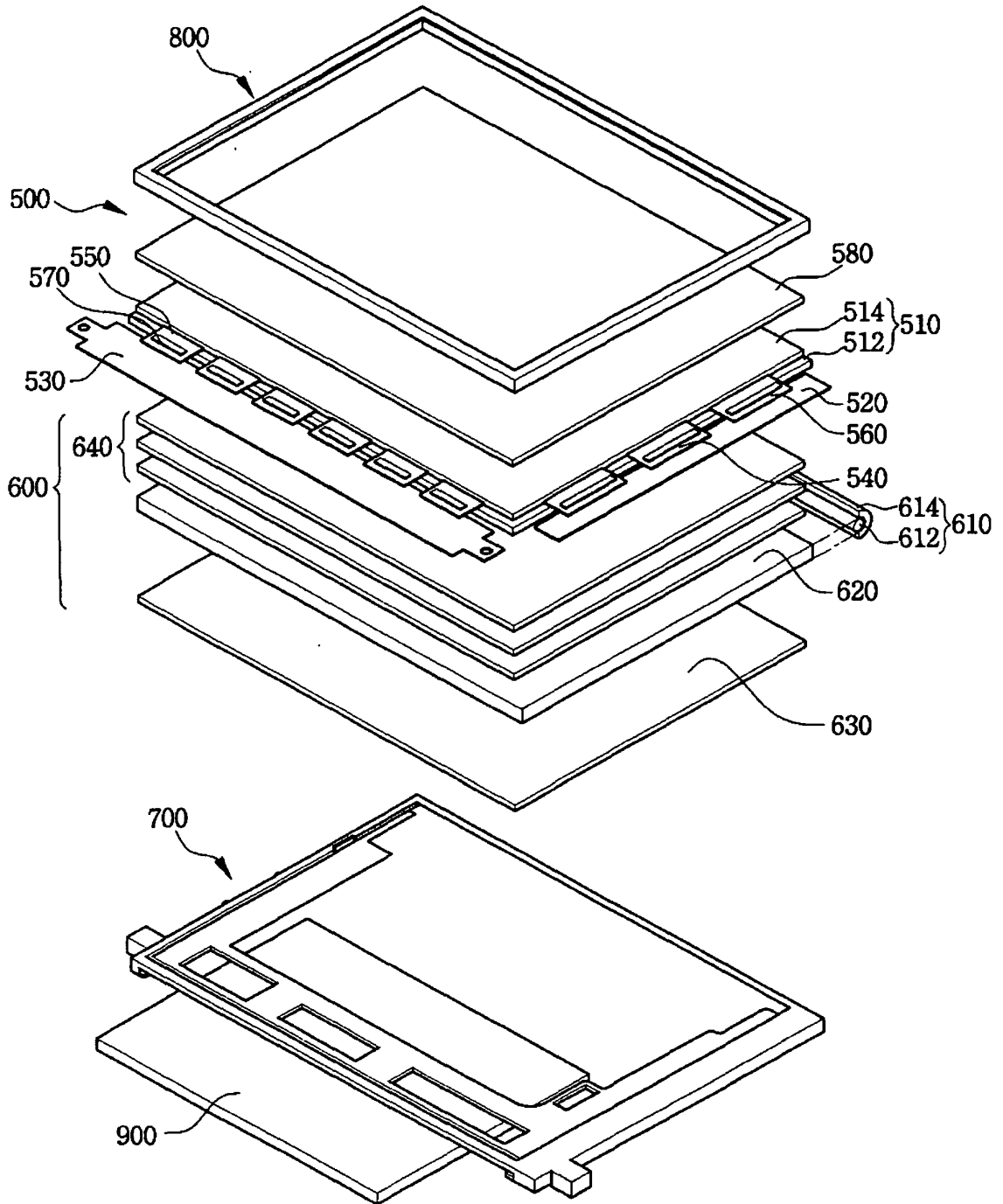

[Fig. 8]

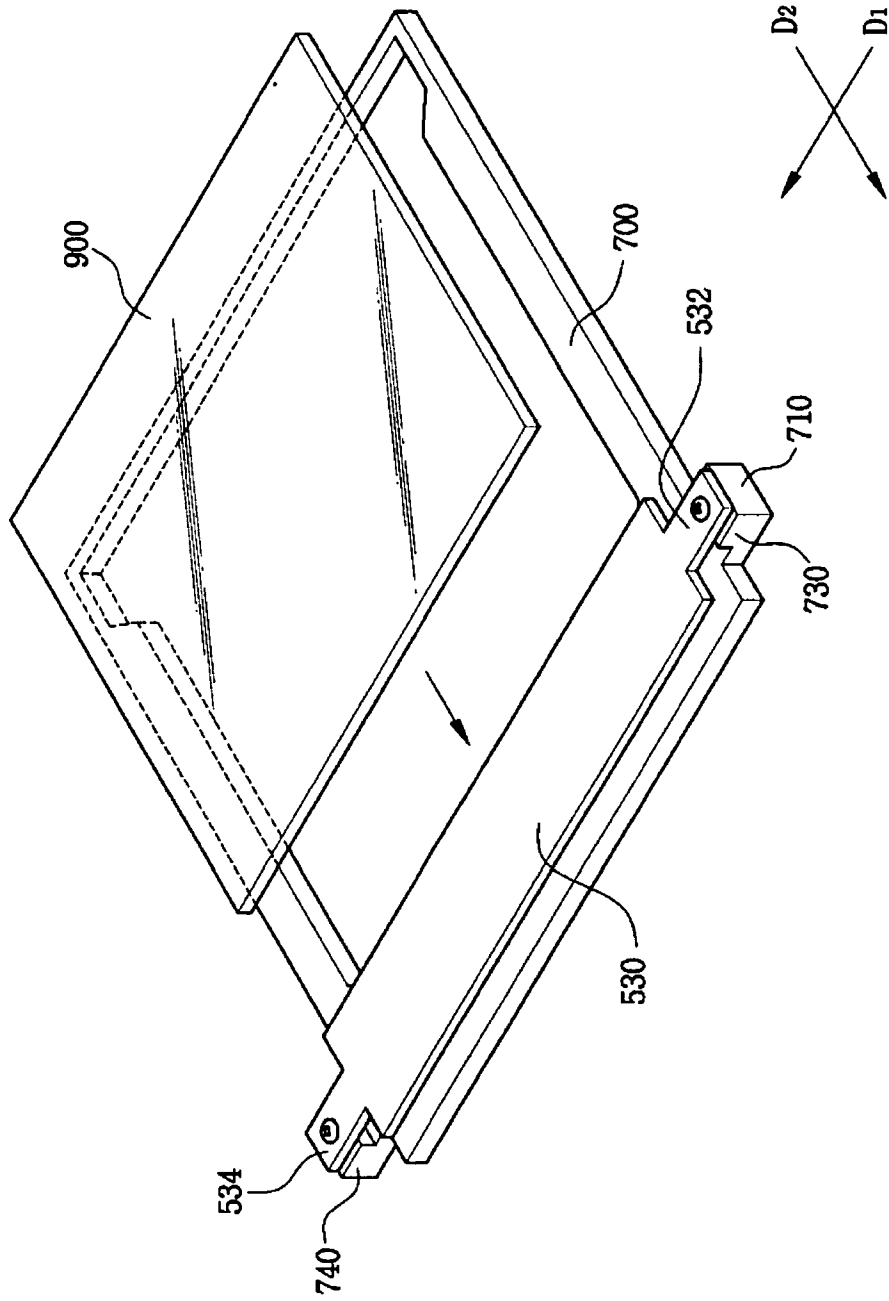

[Fig. 9]

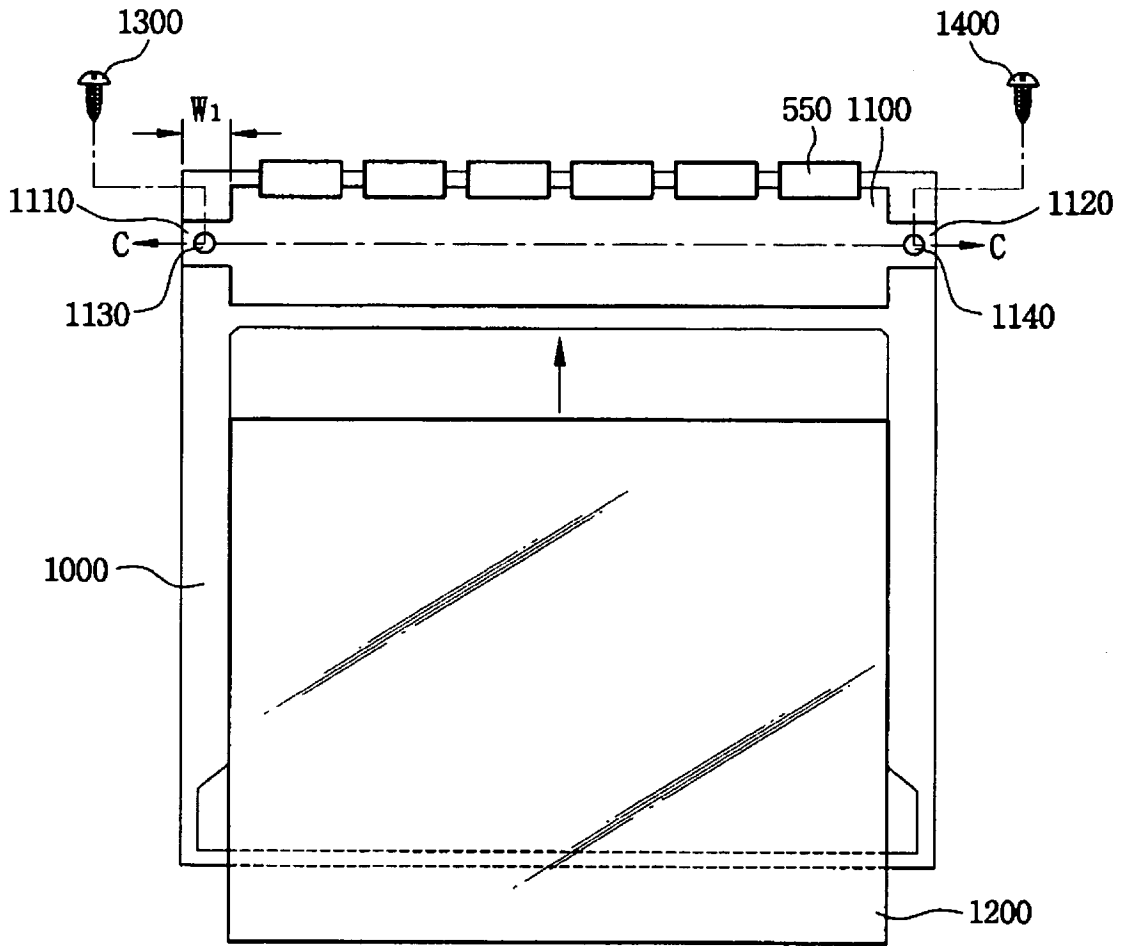

[Fig. 10]

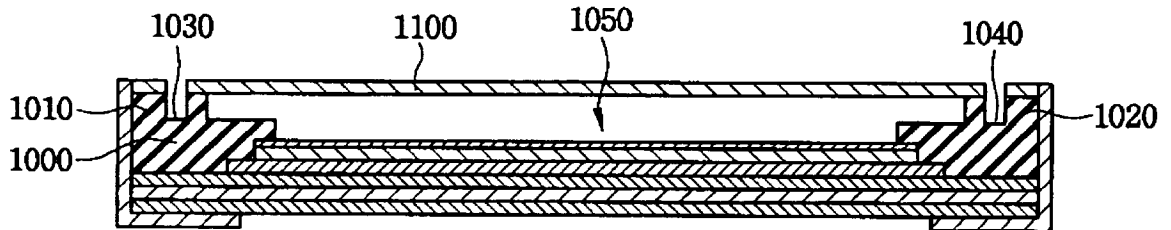

[Fig. 11]

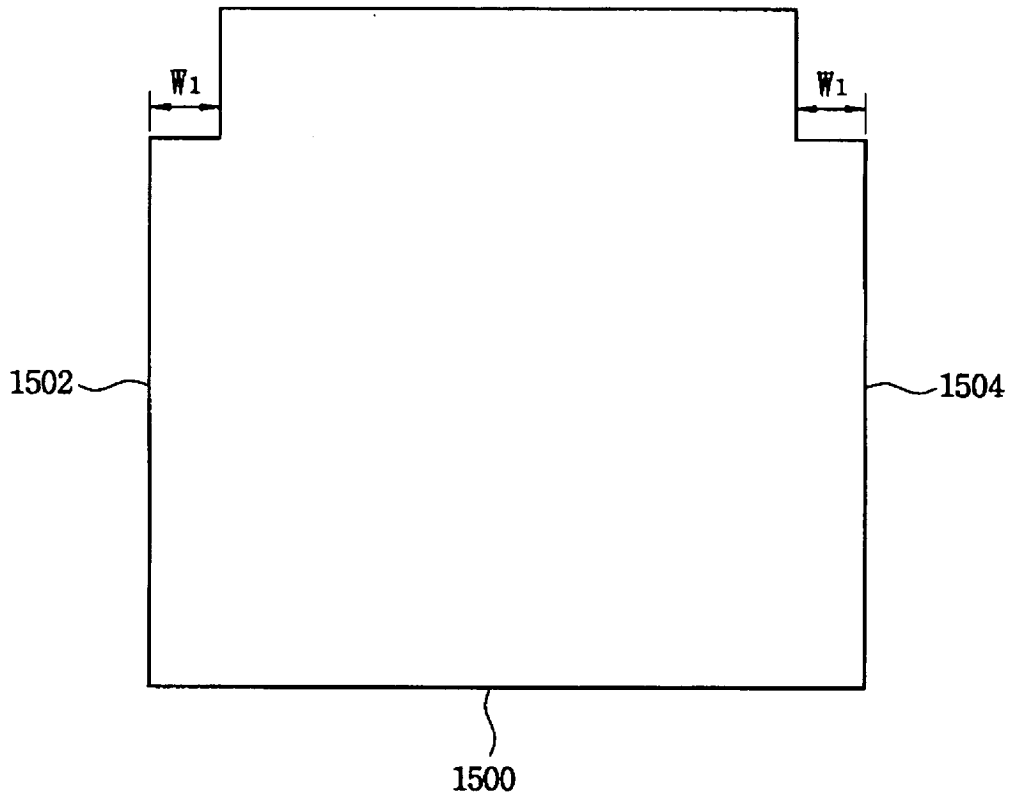

REFERENCES CITED IN THE DESCRIPTION

This list of references cited by the applicant is for the reader's convenience only. It does not form part of the European patent document. Even though great care has been taken in compiling the references, errors or omissions cannot be excluded and the EPO disclaims all liability in this regard.

Patent documents cited in the description

- JP 9043579 A [0005]
- JP 19963221003 B [0005]

专利名称(译)	液晶显示装置		
公开(公告)号	EP1636636B1	公开(公告)日	2009-01-14
申请号	EP2004723094	申请日	2004-03-24
[标]申请(专利权)人(译)	三星电子株式会社		
申请(专利权)人(译)	SAMSUNG ELECTRONICS CO. , LTD.		
当前申请(专利权)人(译)	SAMSUNG ELECTRONICS CO. , LTD.		
[标]发明人	LEE SANG DUK KANG JUNG TAE		
发明人	LEE, SANG-DUK KANG, JUNG-TAE		
IPC分类号	G02F1/1333 G06F1/16 G02F1/13 G02F1/133 G06F3/041 G09F9/00		
CPC分类号	G06F1/1632 G02F1/133308 G02F1/13338 G02F2001/133322 G06F1/1601 G06F1/1626 G06F1/1637		
优先权	1020030041330 2003-06-25 KR		
其他公开文献	EP1636636A1		
外部链接	Espacenet		

摘要(译)

一种液晶显示装置，包括液晶显示面板，驱动器印刷电路板（530），背光组件和模框（700）。驱动器印刷电路板电连接到液晶显示面板，以向液晶显示面板提供图像数据。背光组件设置在液晶显示面板下方。模框具有前侧和后侧。前侧支撑背光组件。第一和第二突出部分（730,740）形成在后侧以支撑驱动器印刷电路板，使得驱动器印刷电路板与接收容器的后侧间隔开。将数字转换器插入到所得到的插入空间（750）中。因此，不需要用于提升数据PCB以将数字转换器插入数据PCB和接收容器之间的工作，从而提高了生产率。

