



(12) **EUROPEAN PATENT APPLICATION**

(43) Date of publication: **29.01.2003 Bulletin 2003/05** (51) Int Cl.⁷: **G02F 1/1335**

(21) Application number: **02016025.5**

(22) Date of filing: **18.07.2002**

<p>(84) Designated Contracting States: AT BE BG CH CY CZ DE DK EE ES FI FR GB GR IE IT LI LU MC NL PT SE SK TR Designated Extension States: AL LT LV MK RO SI</p>	<p>(72) Inventors: <ul style="list-style-type: none"> • Tanada, Tetsushi, c/o Alps Electric Co., Ltd. Tokyo 145-8501 (JP) • Ohizumi, Mitsuo, c/o Alps Electric Co., Ltd. Tokyo 145-8501 (JP) • Kano, Mitsuru, c/o Alps Electric Co., Ltd. Tokyo 145-8501 (JP) </p>
<p>(30) Priority: 27.07.2001 JP 2001228658</p>	
<p>(71) Applicant: ALPS ELECTRIC CO., LTD. Tokyo 145-8501 (JP)</p>	<p>(74) Representative: Klunker . Schmitt-Nilson . Hirsch Winzererstrasse 106 80797 München (DE)</p>

(54) **Semitransparent reflective liquid-crystal display device**

(57) A liquid crystal display device is adopted, in which a liquid crystal cell provided with a pair of transparent substrates (11, 12) facing each other with a liquid crystal layer (34) therebetween, first and second phase difference plates (14, 15) and a first polarizing plate formed sequentially on the outer surface side of the transparent substrate, a reflector (30) attached on the outer surface side of the transparent substrate, and a third phase difference plate (13) and a second polarizing plate (16) formed sequentially on the outer surface side

of the transparent substrate, but on the side farther from the outer surface than is the reflector are included, wherein the reflector is configured by forming a metal reflection film on a base material with concave portions formed thereon while the metal reflection film includes a plurality of concave surfaces corresponding to the concave portions, the metal reflection film is attached to the liquid crystal cell in order to face the transparent substrate side, and the film thickness of the metal reflection film is within the range of 5 to 50nm.

FIG. 2

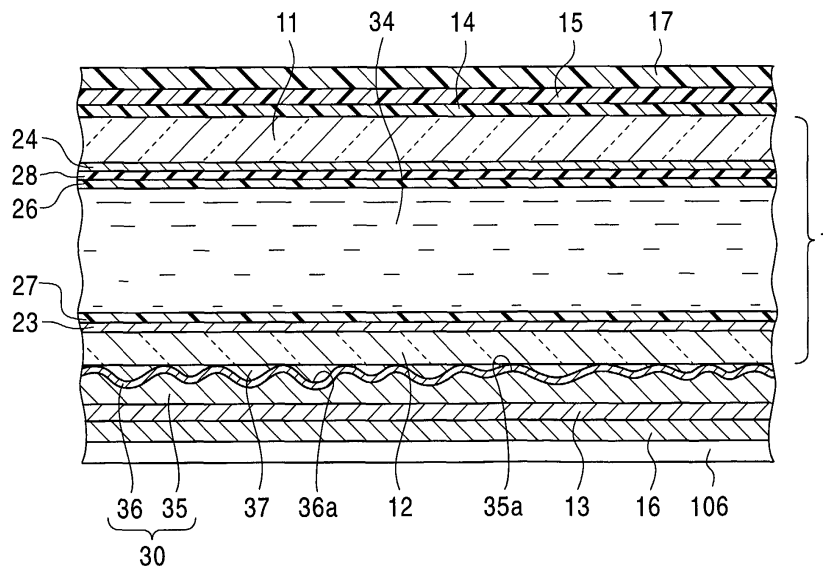

Description

BACKGROUND OF THE INVENTION

5 1. Field of the Invention

[0001] The present invention relates to a liquid crystal display device of external type in which a reflector is placed on the outer surface side of a liquid crystal panel.

10 2. Description of the Related Art

[0002] Regarding cellular phones and portable data terminals at present, liquid crystal display devices are mounted on almost all products. Recently, semitransparent reflective liquid crystal display devices have been mounted on most of these portable electronic devices.

15 **[0003]** The semitransparent reflective liquid crystal display device is provided with a reflection plate for reflecting light incident from an outside on the internal side or external side of a pair of transparent substrates constituting the liquid crystal display device, is further provided with a backlight on the back side thereof and, therefore, can be used while a reflective mode as a reflective liquid crystal display device using sunlight or an external illumination as a light source and a transmissive mode as a transmissive liquid crystal display device using light from the backlight as a light source are switched.

20 **[0004]** Fig. 19 is a diagram showing an example of the partial sectional structure of a conventional semitransparent reflective liquid crystal display device. This semitransparent reflective liquid crystal display device 50 includes a liquid crystal panel 50a having a configuration in which transparent electrode layers 53 and 54 are placed on respective counter-surface sides of a pair of glass substrates 51 and 52, liquid crystal orientation films 55 and 56 are further placed on these transparent electrode layers 53 and 54, respectively, and a liquid crystal layer 57 are placed between these orientation films 55 and 56.

25 **[0005]** A first phase difference plate 66 and a first polarizing plate 68 are laminated on the external side of one glass substrate 51 in that order from the substrate 51 side. A second phase difference plate 67 and a second polarizing plate 69 are placed sequentially on the external side of the other glass substrate 52, and a reflection plate 70 is attached on the external side of the second polarizing plate 69 with a transparent adhesive layer 70a therebetween.

30 **[0006]** In Fig. 19, reference numeral 65 denotes a sealing member for encapsulating the liquid crystal layer 57 between the glass substrates 51 and 52, and reference numeral 75 denotes a backlight placed on the underside of the reflection plate.

35 **[0007]** As shown in Fig. 19 and Fig. 20, for example, a concave and convex surface is formed on the surface of a resin film 71, a semitransparent reflection film 72 made of aluminum, etc., is further formed on this concave and convex surface using an evaporation method, etc., and, therefore, the reflection plate 70 is configured. The film thickness of this semitransparent reflection film 72 is specified to be within the range of 5 to 50 nm, and a part of light from the backlight 75 can be transmitted. This reflection plate 70 is attached while the surface on the semitransparent reflection film 72 side is faced toward the second polarizing plate 59 side.

40 **[0008]** The semitransparent reflective liquid crystal display device 50 having the aforementioned configuration is used as, for example, a display portion of a cellular phone, is operated in the reflective mode without lighting up of the backlight 75 when external light is available adequately, and is operated in the transmissive mode with lighting up of the backlight 75 under circumstances where the external light cannot be available.

45 **[0009]** In the reflective mode, the light incident upon the first polarizing plate 68 is linearly polarized by this polarizing plate 68, and the polarized light is elliptically polarized by passing through the first phase difference plate 66, the liquid crystal layer 57, and the second phase difference plate 67. This elliptically polarized light is linearly polarized by passing through the second polarizing plate 69. This linearly polarized light is reflected at the reflection plate 70, is passed again through the second polarizing plate 69, the second phase difference plate 67, the liquid crystal layer 57, and the first phase difference plate 66, and is emitted from the first polarizing plate 68.

50 **[0010]** In the transmissive mode, the light emitted from the backlight 75 and passed through the semitransparent reflection film 72 is linearly polarized by the second polarizing plate 69, the polarized light is elliptically polarized by passing through the second phase difference plate 67, the liquid crystal layer 57, and the first phase difference plate 66. This elliptically polarized light is linearly polarized by passing through the first polarizing plate 68, and is emitted from the first polarizing plate 68.

55 **[0011]** Meanwhile, as display performances of liquid crystal display devices, in general, it is required that (1) resolution, (2) contrast, (3) luminance of screen, (4) visibility, for example, viewing angle of wide range, and the like are excellent.

[0012] However, regarding the conventional semitransparent reflective liquid crystal display device 50, since the

second polarizing plate 69 has been placed between the reflection plate 70 and the liquid crystal panel 50a, in the reflective mode, there have been problems in that the incident light has been passed through the second polarizing plate 69 twice and, therefore, the whole screen of the semitransparent reflective liquid crystal display device 50 has become light green due to degradation of the spectral characteristic, contrast of the screen has been degraded and, in addition, visibility has been reduced.

[0013] Regarding the conventional semitransparent reflective liquid crystal display device 50, since the reflection efficiency of the reflection plate 70, on which the concave and convex surface has been formed, has been reduced, the reflectance has been reduced as a whole and, therefore, the need of the reflection plate for reflecting the incident light at a reflection angle of wider range has not been met up adequately. Consequently, regarding the semitransparent reflective liquid crystal display device 50 provided with the reflection plate 70 of this sort, there have been problems in that the viewing angle has been within the relatively narrow range of about 25 to 35 degrees, and the luminance of the screen has not been adequate.

[0014] Regarding the conventional semitransparent reflective liquid crystal display device 50, since the phase difference plates and the polarizing plates have been provided by two plates, respectively, the number of parameters of various optical characteristics has been increased and, therefore, optimization of each parameter has been complicated. Especially, in the transmissive mode, the increase in luminance and the improvement in contrast of the screen have been in a condition of being difficult to achieve.

[0015] Consequently, it is considered that the second phase difference plate 67 and the second polarizing plate 69 are removed, the first phase difference plate 68 is made of a laminated plate of two layers exhibiting two different optical characteristics as the phase difference plate, only one plate of the first polarizing plate 68 placed on the first phase difference plate 66 is used as the polarizing plate and, therefore, the white display is lightened when the selection voltage is applied. However, regarding such a semitransparent reflective liquid crystal display device, since it is no more than that the phase difference plate and the polarizing plate are reduced by one plate, respectively, and the reflection efficiency of the reflection plate 70 remains poor, there has been a problem in that not only the light display has been lightened, but also the dark display (black display) is lightened and, therefore, the contrast has been reduced.

SUMMARY OF THE INVENTION

[0016] The present invention has been made in consideration of the aforementioned circumstances. Accordingly, it is an object of the present invention to provide a liquid crystal display device in which no phase difference plate and no polarizing plate are placed between a liquid crystal panel and a reflector placed on the outer surface side thereof and which has a wide viewing angle, high luminance, and high contrast.

[0017] In order to achieve the aforementioned object, the present invention has adopted the following configuration.

[0018] A liquid crystal display device according to the present invention is provided with a liquid crystal cell, in which a transparent electrode and an orientation film are placed on the inner surface side of one transparent substrate of a pair of transparent substrates facing each other with a liquid crystal layer therebetween in that order from the one transparent substrate side, and a transparent electrode and an orientation film are placed on the inner surface side of the other transparent substrate in that order from the other transparent substrate side, first and second phase difference plates and a first polarizing plate formed sequentially on the outer surface side of the aforementioned other transparent substrate, a reflector attached on the outer surface side of the aforementioned one transparent substrate with an adhesive layer therebetween, and a third phase difference plate and a second polarizing plate formed sequentially on the outer surface side of the aforementioned one transparent substrate, but on the side farther from the outer surface than is the aforementioned reflector, wherein the aforementioned reflector is configured by forming a metal reflection film on a base material with a plurality of concave portions formed on the surface while the metal reflection film includes a plurality of concave surfaces corresponding to the aforementioned concave portions, the aforementioned metal reflection film is attached to the liquid crystal cell in order to face the aforementioned one transparent substrate side, and the film thickness of the aforementioned metal reflection film is within the range of 5 to 50 nm.

[0019] According to such a liquid crystal display device, since the second polarizing plate is placed on the external side of the reflector including the metal reflection film having a film thickness of 5 to 50 nm, in a reflective mode, incident light is reflected by the metal reflection film and does not pass through the second polarizing plate and, therefore, spectral characteristics are not degraded, the color of the screen of the liquid crystal display device can be brought close to white, and the contrast ratio of the screen is improved so that it becomes possible to improve the visibility. In a transmissive mode, since light emitted from a backlight passes through the third phase difference plate and the second polarizing plate, passes through the metal reflection film as well and, furthermore, passes through the liquid crystal layer, the first and second phase difference plates, and the first polarizing plate, the light display (white display) is lightened while the dark display (black display) is darkened and, therefore, it becomes possible to improve the contrast ratio.

[0020] In particular, since the aforementioned reflector is configured by forming the metal reflection film on the base

material with the plurality of concave portions formed on the surface while the metal reflection film includes the plurality of concave surfaces corresponding to the aforementioned concave portions, light condensing function is enhanced compared to that of the conventional reflection plate including concavities and convexities on the surface and, therefore, the reflectance can be increased. According to this, the light display in the reflective mode is lightened, the luminance and contrast ratio are improved and, therefore, superior display characteristics can be achieved.

[0021] Regarding the liquid crystal display device according to the present invention, the reflector is placed on the external side of the liquid crystal cell, and when the reflector is attached on the liquid crystal cell, adhesion can be performed at ambient temperature. Consequently, when the liquid crystal cell and the reflector are manufactured separately and, thereafter, the reflector is retrofitted to this liquid crystal cell, since thermal stress is not applied to the liquid crystal cell during manufacture of the reflector, and agents, etc., used during manufacture of the reflector do not fall on the liquid crystal cell, degradation of the liquid crystal cell can be prevented.

[0022] Preferably, the liquid crystal display device according to the present invention is the aforementioned liquid crystal display device, wherein the aforementioned liquid crystal layer has a helical structure twisted 240 degrees to 250 degrees in the direction of the thickness thereof, the retardation (Δn_{LC}) of the aforementioned liquid crystal cell is 600 nm to 800 nm, when the orientation direction a of the orientation film on the aforementioned other transparent substrate side and the orientation direction b of the orientation film on the aforementioned one transparent substrate side are viewed from the incident side of light, and when the direction, which is a direction between the aforementioned orientation directions a and b and which passes at an angle half the interior angle formed by the cross-point O of the aforementioned orientation directions a and b and the aforementioned orientation directions a and b, is referred to as the normal direction X, the retardation (Δn_{RF1}) of the aforementioned first phase difference plate adjacent to the aforementioned other transparent substrate is 100 nm to 200 nm, an angle (ϕ_{RF1}), which a lagging phase axis β of the first phase difference plate forms with respect to the aforementioned normal direction X, is 60 degrees to 100 degrees counterclockwise when viewed from the incident side of the light, the retardation (Δn_{RF2}) of the aforementioned second phase difference plate adjacent to the aforementioned first polarizing plate is 300 nm to 500 nm, an angle (ϕ_{RF2}), which a lagging phase axis γ of the second phase difference plate forms with respect to the aforementioned normal direction X, is 90 degrees to 140 degrees counterclockwise when viewed from the incident side of the light, the retardation (Δn_{RF3}) of the aforementioned third phase difference plate adjacent to the aforementioned one transparent substrate is 132.5 nm to 142.5 nm, an angle (ϕ_{RF3}), which a lagging phase axis δ of the third phase difference plate forms with respect to the aforementioned normal direction X, is 80 degrees to 110 degrees counterclockwise when viewed from the incident side of the light, an angle (ϕ_{pol1}), which an absorption axis α of the aforementioned first polarizing plate forms with respect to the aforementioned normal direction X, is 20 degrees to 70 degrees or 110 degrees to 160 degrees counterclockwise when viewed from the incident side of the light, and an angle (ϕ_{pol2}), which an absorption axis ϵ of the aforementioned second polarizing plate forms with respect to the aforementioned normal direction X, is set at 23 degrees to 43 degrees counterclockwise when viewed from the incident side of the light.

[0023] According to the aforementioned liquid crystal display device, the white display (light display) is further lightened and, therefore, it becomes possible to achieve an increase in luminance of the liquid crystal display device.

[0024] Preferably, the liquid crystal display device according to the present invention is the aforementioned liquid crystal display device, wherein the aforementioned liquid crystal layer has the helical structure twisted 240 degrees in the direction of the thickness thereof, the retardation (Δn_{LC}) of the aforementioned liquid crystal cell is 700 nm, when the orientation direction a of the orientation film on the aforementioned other transparent substrate side and the orientation direction b of the orientation film on the aforementioned one transparent substrate side are viewed from the incident side of light, and when the direction, which is the direction between the aforementioned orientation directions a and b and which passes at the angle half the interior angle formed by the cross-point O of the aforementioned orientation directions a and b and the aforementioned orientation directions a and b, is referred to as the normal direction X, the retardation (Δn_{RF1}) of the aforementioned first phase difference plate adjacent to the aforementioned other transparent substrate is 170 nm, the angle (ϕ_{RF1}), which the lagging phase axis β of the first phase difference plate forms with respect to the aforementioned normal direction X, is 80 degrees counterclockwise when viewed from the incident side of the light, the retardation (Δn_{RF2}) of the aforementioned second phase difference plate adjacent to the aforementioned first polarizing plate is 425 nm, the angle (ϕ_{RF2}), which the lagging phase axis γ of the second phase difference plate forms with respect to the aforementioned normal direction X, is 113 degrees counterclockwise when viewed from the incident side of the light, the retardation (Δn_{RF3}) of the aforementioned third phase difference plate adjacent to the aforementioned one transparent substrate is 137.5 nm, the angle (ϕ_{RF3}), which the lagging phase axis δ of the third phase difference plate forms with respect to the aforementioned normal direction X, is 90 degrees counterclockwise when viewed from the incident side of the light, the angle (ϕ_{pol1}), which the absorption axis α of the aforementioned first polarizing plate forms with respect to the aforementioned normal direction X, is 42 degrees counterclockwise when viewed from the incident side of the light, and the angle (ϕ_{pol2}), which the absorption axis ϵ of the aforementioned second polarizing plate forms with respect to the aforementioned normal direction X, is set at 33 degrees counterclockwise when viewed from the incident side of the light.

[0025] According to the aforementioned liquid crystal display device, the white display (light display) is further lightened and, therefore, it becomes possible to achieve an increase in luminance of the liquid crystal display device. In particular, according to the aforementioned liquid crystal display device, the display color of the white display (light display) can be brought closer to white and, therefore, it becomes possible to improve the color purity and the visibility.

[0026] Preferably, the liquid crystal display device according to the present invention is the aforementioned liquid crystal display device, wherein the aforementioned liquid crystal layer has the helical structure twisted 240 degrees to 250 degrees in the direction of the thickness thereof, the retardation (Δn_{LC}) of the aforementioned liquid crystal cell is 600 nm to 800 nm, when the orientation direction a of the orientation film on the aforementioned other transparent substrate side and the orientation direction b of the orientation film on the aforementioned one transparent substrate side are viewed from the incident side of light, and when the direction, which is the direction between the aforementioned orientation directions a and b and which passes at the angle half the interior angle formed by the cross-point O of the aforementioned orientation directions a and b and the aforementioned orientation directions a and b, is referred to as the normal direction X, the retardation (Δn_{RF1}) of the aforementioned first phase difference plate adjacent to the aforementioned other transparent substrate is 100 nm to 200 nm, the angle (ϕ_{RF1}), which the lagging phase axis β of the first phase difference plate forms with respect to the aforementioned normal direction X, is 60 degrees to 100 degrees counterclockwise when viewed from the incident side of the light, the retardation (Δn_{RF2}) of the aforementioned second phase difference plate adjacent to the aforementioned first polarizing plate is 300 nm to 500 nm, the angle (ϕ_{RF2}), which the lagging phase axis γ of the second phase difference plate forms with respect to the aforementioned normal direction X, is 90 degrees to 140 degrees counterclockwise when viewed from the incident side of the light, the retardation (Δn_{RF3}) of the aforementioned third phase difference plate adjacent to the aforementioned one transparent substrate is 120 nm to 130 nm, the angle (ϕ_{RF3}), which the lagging phase axis δ of the third phase difference plate forms with respect to the aforementioned normal direction X, is 48 degrees to 68 degrees counterclockwise when viewed from the incident side of the light, the angle (ϕ_{pol1}), which an absorption axis α of the aforementioned first polarizing plate forms with respect to the aforementioned normal direction X, is 20 degrees to 70 degrees or 110 degrees to 160 degrees counterclockwise when viewed from the incident side of the light, and the angle (ϕ_{pol2}), which an absorption axis ε of the aforementioned second polarizing plate forms with respect to the aforementioned normal direction X, is set at 3 degrees to 23 degrees counterclockwise when viewed from the incident side of the light.

[0027] According to the aforementioned liquid crystal display device, the white display (light display) is further lightened and, in addition, the black display (dark display) is further darkened, so that it becomes possible to increase the contrast ratio.

[0028] Preferably, the liquid crystal display device according to the present invention is the aforementioned liquid crystal display device, wherein the aforementioned liquid crystal layer has the helical structure twisted 240 degrees in the direction of the thickness thereof, the retardation (Δn_{LC}) of the aforementioned liquid crystal cell is 700 nm, when the orientation direction a of the orientation film on the aforementioned other transparent substrate side and the orientation direction b of the orientation film on the aforementioned one transparent substrate side are viewed from the incident side of light, and when the direction, which is the direction between the aforementioned orientation directions a and b and which passes at the angle half the interior angle formed by the cross-point O of the aforementioned orientation directions a and b and the aforementioned orientation directions a and b, is referred to as the normal direction X, the retardation (Δn_{RF1}) of the aforementioned first phase difference plate adjacent to the aforementioned other transparent substrate is 170 nm, the angle (ϕ_{RF1}), which the lagging phase axis β of the first phase difference plate forms with respect to the aforementioned normal direction X, is 80 degrees counterclockwise when viewed from the incident side of the light, the retardation (Δn_{RF2}) of the aforementioned second phase difference plate adjacent to the aforementioned first polarizing plate is 425 nm, the angle (ϕ_{RF2}), which the lagging phase axis γ of the second phase difference plate forms with respect to the aforementioned normal direction X, is 113 degrees counterclockwise when viewed from the incident side of the light, the retardation (Δn_{RF3}) of the aforementioned third phase difference plate adjacent to the aforementioned one transparent substrate is 125 nm, the angle (ϕ_{RF3}), which the lagging phase axis δ of the third phase difference plate forms with respect to the aforementioned normal direction X, is 58 degrees counterclockwise when viewed from the incident side of the light, the angle (ϕ_{pol1}), which the absorption axis α of the aforementioned first polarizing plate forms with respect to the aforementioned normal direction X, is 42 degrees counterclockwise when viewed from the incident side of the light, and the angle (ϕ_{pol2}), which the absorption axis ε of the aforementioned second polarizing plate forms with respect to the aforementioned normal direction X, is set at 13 degrees counterclockwise when viewed from the incident side of the light.

[0029] According to the aforementioned liquid crystal display device, the white display (light display) is further lightened and, in addition, the black display (dark display) is further darkened, so that it becomes possible to further increase the contrast ratio of the liquid crystal display device. In particular, according to the aforementioned liquid crystal display device, the display color of the white display (light display) can be brought closer to white and, therefore, it becomes possible to improve the color purity and the visibility.

[0030] Preferably, the liquid crystal display device according to the present invention is the aforementioned liquid

crystal display device, wherein the N_z coefficient represented by the following Formula (1) of the aforementioned first phase difference plate is set within the range of -0.5 to 2.0, and the N_z coefficient represented by the following Formula (1) of the aforementioned second phase difference plate is set within the range of -0.5 to 2.0.

$$N_z = (n_x - n_z)/(n_x - n_y) \quad \text{Formula (1)}$$

[0031] (In the formula, n_x denotes a refractive index in the X axis direction of the phase difference plate, n_y denotes a refractive index in the Y axis direction of the phase difference plate, and n_z denotes a refractive index in the Z axis direction of the phase difference plate.)

[0032] According to such a liquid crystal display device, the range, in which contrast is excellent, is extended in the vertical and horizontal directions of the display surface. Consequently, the viewing angle is increased in the vertical and horizontal directions of the display surface and, therefore, the one having superior visual angle characteristic can be achieved.

[0033] Preferably, the liquid crystal display device according to the present invention is the aforementioned liquid crystal display device, wherein the N_z coefficient represented by the aforementioned Formula (1) of the aforementioned first phase difference plate is set at 0.5, and the N_z coefficient represented by the aforementioned Formula (1) of the aforementioned second phase difference plate is set at 0.3.

[0034] According to such a liquid crystal display device, the range, in which contrast is excellent, is further extended in the vertical and horizontal directions of the display surface. Consequently, the viewing angle is further increased in the vertical and horizontal directions of the display surface and, therefore, further superior visual angle characteristic can be achieved.

[0035] Preferably, the liquid crystal display device according to the present invention is the aforementioned liquid crystal display device, wherein the aforementioned plurality of concave surfaces of the aforementioned metal reflection film are formed continuously, and each concave surface is made of a part of a sphere.

[0036] According to such a liquid crystal display device, when the plurality of concave surfaces of the metal reflection film are continuous, and each concave surface has the shape of a part of a sphere, the reflection efficiency of the light can be improved remarkably compared to that heretofore attained. Consequently, it is possible to thin the metal reflection film in order to improve the translucency of the liquid crystal display device and, therefore, well-lighted display as a transmissive liquid crystal display device can be achieved as well. According to this, the well-lighted display can be achieved in the action of either reflective type or transmissive type.

[0037] Preferably, the liquid crystal display device according to the present invention is the aforementioned liquid crystal display device, wherein the depths of the aforementioned plurality of concave portions are within the range of 0.1 μm to 3 μm , the distribution of the angles of inclination of the aforementioned concave portion inner surfaces is within the range of -30 degrees to +30 degrees, and the pitches between adjacent concave portions are within the range of 5 μm to 50 μm .

[0038] According to such a liquid crystal display device, since the surface shape of the aforementioned base material can be made optimum, it is possible to more efficiently reflect the light incident from the outside and, therefore, further well-lighted display can be achieved.

[0039] Preferably, the liquid crystal display device according to the present invention is the aforementioned liquid crystal display device, wherein the aforementioned plurality of concave portions include a first longitudinal section and a second longitudinal section, each passing the deepest point of the concave portion, the shape of the inner surface of the aforementioned first longitudinal section is composed of a first curve from one periphery portion of the concave portion to the deepest point and a second curve from the deepest point to other periphery portion of the concave portion in succession to this first curve, and the average value of the absolute values of the angles of inclination of the first curve with respect to the base material surface is specified to be larger than the average value of the absolute values of the angles of inclination of the second curve with respect to the base material surface, while the aforementioned second longitudinal section is orthogonal to the first longitudinal section, and the shape of the inner surface thereof is composed of a shallow type curve and deep type curves existing on both sides of the shallow type curve and having curvature radii smaller than that of the shallow type curve.

[0040] In the present specification, although it is not specifically limited which direction of longitudinal section is assumed to be the first longitudinal section, it is desirable that the longitudinal section in the vertical or fore-and-aft direction when viewed from an observer is assumed to be the first longitudinal section.

[0041] According to such a liquid crystal display device, the inner surface shape of the concave portion is formed into a curve which is composed of the first curve and the second curve, the boundary therebetween being the deepest point in the first longitudinal section, and in which the average value of the absolute values of the angles of inclination of the first curve with respect to the base material surface is specified to be larger than the average value of the absolute

values of the angles of inclination of the second curve with respect to the base material surface. That is, the inclination of the first curve is relatively steep, the inclination of the second curve is relatively gentle, and the second curve is longer than the first curve.

5 [0042] Consequently, the quantity of light reflected at the surface in the periphery of the second curve is more than that of light reflected at the surface in the periphery of the first curve. That is, reflection is performed in order that the luminous flux density in the direction of the specular reflection with respect to the surface in the periphery of the second curve becomes high. Therefore, when the directions of respective first curves of the concave portions are arranged in the specified direction (single or a plurality of specified directions), the reflection intensity in the specified direction can be increased as the total reflector.

10 [0043] Furthermore, since each inner surface shape of these concave portions in the second longitudinal section orthogonal to the first longitudinal section is formed in order to include the shallow type curve and the deep type curves existing on both sides of the shallow type curve and having small curvature radii, the reflectance nearly in the direction of the specular reflection can be increased. It is desirable that the deep type curves exist evenly on both sides of the shallow type curve.

15 [0044] Consequently, regarding the total reflection characteristics in the first longitudinal section, the reflectance has a peak at an angle of the specular reflection and, in addition, the reflectance toward the direction of reflection by the surface in the periphery of the second curve is increased. That is, it is possible to achieve the reflection characteristic which can condense the reflected light moderately in the specified direction while the reflected light in the direction of the specular reflection is ensured adequately.

20 [0045] Preferably, the liquid crystal display device according to the present invention is the aforementioned liquid crystal display device, wherein the aforementioned plurality of concave portions are formed in order that each of the first longitudinal sections and the second longitudinal sections is in the same direction, and each of the first curves is orientated unidirectionally, and the reflector is placed in order that the first curves in respective concave portions locate above the second curves when viewed from the observer.

25 [0046] That is, the first curves of respective concave portions are orientated unidirectionally and, in addition, the second curves of respective concave portions are also orientated unidirectionally.

[0047] According to such a liquid crystal display device, as the total reflector, the reflectance in the direction of reflection by the surface in the periphery of the second curve is increased. That is, it is possible to achieve the reflection characteristic which can condense moderately the reflected light toward the specified direction.

30 [0048] When all the first curves in concave portions are placed in order to locate above the second curves when viewed from the observer, in general, external light, etc., primarily incident from above can be shifted toward the direction of the normal to the base material surface rather than the direction toward the feet of the observer.

[0049] Since the external light, etc., primarily incident from above when viewed from the observer is efficiently entered into the surface in the periphery of the second curve, the quantity of the reflected light is increased as a whole.

35 [0050] Furthermore, the quantity of light in the direction of the specular reflection can be ensured adequately by the reflection from the shallow curve in the second longitudinal section.

[0051] Consequently, the quantity of light reflected in the direction of the line of sight of the observer is increased and, therefore, a reflective liquid crystal display device with a well-lighted display at the practical point of view is realized.

40 [0052] Preferably, the liquid crystal display device according to the present invention is the aforementioned liquid crystal display device, wherein the angles of inclination of the aforementioned first curve and the second curve become zero with respect to the base material surface at the position where they are in contact with each other.

[0053] According to such a liquid crystal display device, since the whole concave portion inner surface can be formed gently, it is possible to avoid reduction of the quantity of reflection in the direction of the specular reflection.

45 [0054] Preferably, the liquid crystal display device according to the present invention is the aforementioned liquid crystal display device, wherein the depths of the aforementioned plurality of concave portions are within the range of 0.1 μm to 3 μm and are formed on a random basis.

[0055] When the depth of concave portion is less than 0.1 μm , scattering effect of light is inadequate. When exceeding 3 μm , the thickness of the base material for realizing this depth becomes excessively large and, therefore, inconvenience is brought about in manufacture as well as in product. When the depths of the plurality of concave portions are formed on a random basis, occurrence of the moiré pattern due to interference of light which is likely to occur when the depths of the concave portions are formed regularly is prevented, peak-like condensation of the quantity of reflected light at a specified visual angle is alleviated and, therefore, change of the quantity of reflected light in the visual angle becomes gentle.

50 [0056] Preferably, the liquid crystal display device according to the present invention is the aforementioned liquid crystal display device, wherein the aforementioned plurality of concave portions are placed adjacently to each other on a random basis.

55 [0057] When the interval between concave portions is large, since a flat surface is brought about between the concave portions, plane reflection is increased, and adequate diffuse reflection effect cannot be achieved in a limited pixel

region. Consequently, the concave portions are preferably formed adjacently to each other. Since the moiré pattern occurs when the concave portions are arranged regularly, the concave portions are preferably arranged on a random basis.

[0058] Preferably, the liquid crystal display device according to the present invention is the aforementioned liquid crystal display device, wherein the reflectance reaches a peak at the angle of the specular reflection with respect to the aforementioned metal reflection film surface, the integral of reflectance within the range of the reflection angle smaller than the angle of the specular reflection and the integral of reflectance within the range of the reflection angle larger than the angle of the specular reflection are different, and the range of the reflection angle, in which the aforementioned integral of reflectance becomes large, of the total reflector is set above the angle of the specular reflection with respect to the metal reflection film surface when viewed from the observer.

[0059] According to such a liquid crystal display device, and according to the present invention, when the usual viewing angle of the observer is deviated from the direction of the specular reflection, the reflector capable of reflecting light primarily in the direction of the usual viewing angle can be achieved while the reflected light in the direction of the specular reflection is ensured.

[0060] In general, external light, etc., primarily incident from above can be shifted toward the direction of the normal to the base material surface rather than the direction toward the feet of the observer.

[0061] Consequently, for example, when used as a display device of a cellular phone and a notebook computer, the quantity of light reflected in the direction of the line of sight of the observer is increased and, therefore, a reflective liquid crystal display device with a well-lighted display at the practical point of view is realized.

[0062] In the liquid crystal display device according to the present invention, a color filter may be placed between the one transparent substrate constituting the aforementioned liquid crystal cell and the transparent electrode placed on the inner surface side thereof.

BRIEF DESCRIPTION OF THE DRAWINGS

[0063]

Fig. 1 is a front view showing the display portion of a portable data terminal provided with a liquid crystal display device according to an embodiment of the present invention.

Fig. 2 is a sectional view showing the mode in which a liquid crystal display device according to an embodiment of the present invention is applied to an STN type semitransparent reflective liquid crystal display device.

Fig. 3 is a diagram showing a key portion of a semitransparent reflective liquid crystal display device according to an embodiment of the present invention, and is a perspective exploded view showing the optimum condition for increasing luminance.

Fig. 4 is a diagram showing the arrangement relationship among an absorption axis α of a first polarizing plate, a lagging phase axis β of a first phase difference plate, a lagging phase axis γ of a second phase difference plate, the orientation direction a of an upper orientation film, the orientation direction b of a lower orientation film, a lagging phase axis δ of a second phase difference plate, and an absorption axis ϵ of a second polarizing plate of a semitransparent reflective liquid crystal display device according to an embodiment of the present invention, and is a plan view showing the optimum condition for increasing luminance.

Fig. 5 is a diagram showing a key portion of a semitransparent reflective liquid crystal display device according to an embodiment of the present invention, and is a perspective exploded view showing the optimum condition for increasing contrast ratio.

Fig. 6 is a diagram showing the arrangement relationship among an absorption axis α of a first polarizing plate, a lagging phase axis β of a first phase difference plate, a lagging phase axis γ of a second phase difference plate, the orientation direction a of an upper orientation film, the orientation direction b of a lower orientation film, a lagging phase axis δ of a second phase difference plate, and an absorption axis ϵ of a second polarizing plate of a semitransparent reflective liquid crystal display device according to an embodiment of the present invention, and is a plan view showing the optimum condition for increasing contrast ratio.

Fig. 7 is a perspective view showing an example of a reflector provided in the semitransparent reflective liquid crystal display device shown in Fig. 2.

Fig. 8 is a perspective view showing another example of a reflector provided in the semitransparent reflective liquid crystal display device shown in Fig. 2.

Fig. 9 is a perspective view showing a concave portion placed on the base material surface of the reflector shown in Fig. 8.

Fig. 10 is a sectional view in a first longitudinal section of the concave portion shown in Fig. 9.

Fig. 11 is a sectional view in a second longitudinal section of the concave portion shown in Fig. 9.

Fig. 12 is a schematic diagram explaining the reflection characteristics of the reflector shown in Fig. 8.

Fig. 13 is a graph showing the relationship between the acceptance angle and the reflectance.

Fig. 14 is a schematic diagram explaining the use of a semitransparent reflective liquid crystal display device according to the present embodiment provided with the reflector shown in Fig. 8.

Fig. 15 is a graph showing the reflectance in Example (Sample No. 4) when light is entered at 15 degrees.

Fig. 16 is a graph showing the contrast in Example (Sample No. 4) when light is entered at 15 degrees.

Fig. 17 is a graph showing the reflectance in Comparative example when light is entered at 15 degrees.

Fig. 18 is a graph showing the contrast in Comparative example when light is entered at 15 degrees.

Fig. 19 is a sectional view showing the outline configuration of a conventional semitransparent reflective liquid crystal display device.

Fig. 20 is a perspective view showing a reflection plate provided in the semitransparent reflective liquid crystal display device shown in Fig. 19.

DESCRIPTION OF THE PREFERRED EMBODIMENTS

[0064] The embodiments according to the present invention will be described below with reference to the drawings.

[0065] Fig. 1 is a front view showing an embodiment of the display portion of a portable data terminal provided with a semitransparent reflective liquid crystal display device according to an embodiment in which a liquid crystal display device of the present invention is applied to an STN type semitransparent reflective liquid crystal display device.

[0066] The display portion of the portable data terminal according to the present invention is provided with at least a frame member 100 and a semitransparent reflective liquid crystal display device 101 according to the present embodiment stored in the frame member 100. The semitransparent reflective liquid crystal display device 101 according to this embodiment is of horizontal type.

[0067] As shown in Fig. 2, the semitransparent reflective liquid crystal display device 101 according to the present embodiment is configured roughly by placing a liquid crystal cell 1, placing a first phase difference plate (phase difference plate adjacent to the other transparent substrate) 14, a second phase difference plate (phase difference plate adjacent to a polarizing plate) 15, and a first polarizing plate 17 on the outer surface side of an upper glass substrate (the other transparent substrate) 11 of the liquid crystal cell 1 in that order from the upper glass substrate 11 side, placing a reflector 30 on the outer surface side of the lower glass substrate (the one transparent substrate) 12 of the liquid crystal cell 1, and further placing a third phase difference plate 13 and a second polarizing plate 16 on the outer surface side of the reflector 30. A backlight 106 is attached on the underside of the second polarizing plate 16.

[0068] The aforementioned liquid crystal cell 1 is configured roughly by placing a common electrode (transparent electrode) 23 and a lower orientation film (orientation film on the one transparent substrate side) 27 on the inner surface side of the lower glass substrate 12 of the upper and lower glass substrates 11 and 12 facing each other with a liquid crystal layer 34 therebetween in that order from the lower glass substrate 12 side, and placing a segment electrode (transparent substrate) 24, a topcoat 28, and an upper orientation film (orientation film on the other transparent substrate side) 26 on the inner surface side of the upper glass substrate 11 in that order from the upper glass substrate 11 side.

[0069] The semitransparent reflective liquid crystal display device 101 having the aforementioned configuration is operated in the reflective mode without lighting up of the backlight 106 when external light is available adequately, and is operated in the transmissive mode with lighting up of the backlight 106 under circumstances where the external light cannot be available.

[0070] In the reflective mode, the light incident upon the first polarizing plate 17 is linearly polarized by this polarizing plate 17, and the polarized light is elliptically polarized by passing through the first and second phase difference plates 14 and 15 and the liquid crystal layer 34. This elliptically polarized light is reflected at the reflection plate 30, is passed again through the liquid crystal layer 34 and the first and second phase difference plates 14 and 15, is linearly polarized again by the first polarizing plate 17, and is emitted.

[0071] In the transmissive mode, the light emitted from the backlight 106 is linearly polarized by the second phase difference plate 16, the polarized light is elliptically polarized by passing through the third phase difference plate 13, the liquid crystal layer 34, and the first and second phase difference plates 14 and 15. This elliptically polarized light is linearly polarized by passing through the first polarizing plate 17, and is emitted from the first polarizing plate 17. The reflector 30 interposing between the third phase difference plate 13 and the liquid crystal layer 34 is provided with a metal reflection film 36 having a thickness of 5 to 50 nm, as described later, and can transmit a part of the light emitted from the backlight 106.

[0072] Consequently, the semitransparent reflective liquid crystal display device 101 according to the present embodiment is configured in order that the light passes through the third phase difference plate 13 and the second polarizing plate 16 only in the case of the transmissive mode.

[0073] Transparent orientation films, which are used commonly and which are macromolecular films, for example, polyimide, having been subjected to a rubbing treatment, are used as the upper and lower orientation films 26 and 27.

[0074] In this embodiment, the orientation direction (rubbing direction) of the upper orientation film 26 is set within

the range on the order of -35 degrees to -25 degrees, and preferably, is set at -30 degrees (+330 degrees), wherein as shown in Fig. 3 to Fig. 6, the counterclockwise direction is indicated by +, and the clockwise direction is indicated by - when viewed from the light incident side.

[0075] In this embodiment, the orientation direction (rubbing direction) b of the lower orientation film 27 is set within the range on the order of +25 degrees to +35 degrees, and preferably, is set at +30 degrees, wherein as shown in Fig. 3 to Fig. 6, the counterclockwise direction is indicated by +, and the clockwise direction is indicated by - when viewed from the light incident side.

[0076] Herein, when the orientation direction a of the upper orientation film 26 and the orientation direction b of the lower orientation film 27 are viewed from the incident side of the light as shown in Fig. 4 to Fig. 6, the direction, which is a direction between the aforementioned orientation directions a and b and which passes at an angle half the interior angle formed by the cross-point O of the aforementioned orientation directions a and b and the aforementioned orientation directions a and b, is referred to as the normal direction X.

[0077] In Fig. 3 and Fig. 5, reference numeral Z denotes the directions orthogonal to the respective surfaces on the incident side of the light of the liquid crystal cell 1, the first, second, and third phase difference plates 14, 15, and 13, and the first and second polarizing plate 17 and 16.

[0078] The aforementioned liquid crystal layer 34 has preferably a helical structure twisted 240 degrees to 250 degrees in the direction of the thickness thereof, more preferably, has a helical structure twisted 240 degrees (the twist angle of the liquid crystal molecule constituting the liquid crystal layer 34 is 240 degrees to 250 degrees), and is made of a liquid crystal molecule which is encapsulated in the region surrounded by the upper and lower orientation films 26 and 27 placed on the internal side of the upper and lower glass substrates 11 and 12 and a seal member (not shown in the drawing) joining these orientation films 26 and 27 while a predetermined interval is ensured and which is in a nematic state at ambient temperature. As this liquid crystal molecule, the one of super twisted nematic (STN) type is used.

[0079] Preferably, a liquid crystal, in which the wavelength dispersion characteristic of the double refractive index (Δn_{LC}) of the liquid crystal is smaller than the wavelength dispersion characteristic of the double refractive index (Δn_{RF1}) of the first phase difference plate 14, the wavelength dispersion characteristic of the double refractive index (Δn_{RF2}) of the second phase difference plate 15, and the wavelength dispersion characteristic of the double refractive index (Δn_{RF3}) of the third phase difference plate 13, is used as the liquid crystal constituting this liquid crystal layer 34 from the viewpoint of achieving high contrast and achieving superior display characteristics.

The wavelength dispersion characteristic of the (Δn_{LC}) of the liquid crystal constituting the liquid crystal layer 34 can be changed by changing the liquid crystal material itself. The wavelength dispersion characteristics of Δn_{RF1} , Δn_{RF2} , and Δn_{RF3} of the first, second, and third phase difference plates 14, 15, and 13 can be changed by changing the material of each phase difference plate.

[0080] The topcoat 28 is placed for ensuring an insulation property, and is made of an inorganic material, for example, silica and ZrO_2 .

[0081] In the present embodiment, the upper glass substrate 11 is made of soda lime glass, etc., although it is varied depending on the sort of the liquid crystal display device. The thickness of this upper glass substrate 11 is preferably specified to be 0.3 mm to 1.1 mm, although it is varied depending on the sort of the liquid crystal display device.

[0082] In the present embodiment, soda lime glass containing an oxide of alkali metal, for example, sodium, or the like is used as the lower glass substrate (the one transparent substrate) 12 although it is varied depending on the sort of the liquid crystal display device. The thickness of this lower glass substrate 12 is preferably specified to be 0.3 mm to 1.1 mm.

[0083] As shown in Fig. 2 and Fig. 7, the reflector 30 is configured by forming the metal reflection film 36 on the base material 35 with a plurality of concave portions 35a formed on the surface while the metal reflection film 36 has a plurality of concave surfaces 36a corresponding to the respective concave portions 35a. The metal reflection film 30 is adhered to the lower substrate 12 of the liquid crystal cell 1 with a transparent adhesive layer 37 made of an epoxy-based material containing fluorine in order that the metal reflection film 36 faces the lower glass substrate 12 side.

[0084] The base material 35 is placed in order to impart a concave and convex shape to the metal reflection film 36 formed thereon and, therefore, the reflected light is scattered efficiently. By impartation of the concave and convex shape to the metal reflection film 36, since the light incident upon the liquid crystal display device 101 can be reflected efficiently, well-lighted display can be realized in the reflective mode.

[0085] Fig. 7 is a perspective view showing the base material 35 and a portion including the metal reflection film 36 formed thereon. As shown in this drawing, on the surface of the metal reflection film 36, large numbers of concave surfaces 36a having the inner surface constituting a part of a sphere are formed continuously while horizontally overlapping each other. The shapes of the concave surfaces 36a correspond to the shapes of the concave portions 35a of the base material.

[0086] Desirably, the depths of the concave portions 35a are formed within the range of 0.1 μm to 3 μm on a random basis, the pitches between adjacent concave portions 35a are arranged within the range of 5 μm to 50 μm on a random

basis, and the angles of inclination of the concave portion 35a inner surfaces are set within the range of -30 degrees to +30 degrees.

[0087] In particular, it is important that the distribution of the angles of inclination of the concave portion 35a inner surfaces is set within the range of -30 degrees to +30 degrees, and the pitches between adjacent concave portions 35a are arranged on a random basis with respect to all directions in the plane. This is because if the pitches between adjacent concave portions 35a have regularity, there is a problem in that an interference color appears and, therefore, the reflected light is colored. Furthermore, this is because when the distribution of the angles of inclination of the concave portion 35a inner surfaces exceeds the range of -30 degrees to +30 degrees, the diffusion angle of the reflected light is excessively increased and, therefore, the reflection intensity is reduced and well-lighted display cannot be achieved (this is because the diffusion angle of the reflected light becomes 36 degrees or more in air and, therefore, the reflection intensity peak inside the liquid crystal display device is reduced and the total reflection loss is increased).

[0088] When the depths of the concave portions 35a exceed 3 μm , since the crests of the convex portions cannot be berried completely with the adhesive layer 37 during the later step of flattening the concave portions 35a, desired flatness cannot be achieved and, therefore, unevenness in display is brought about.

[0089] When the pitches between adjacent concave portions 35a are less than 5 μm , there are constraints regarding manufacture of a transfer mold used for forming the base material and, therefore, problems occur in that a processing time is increased by a large degree, a shape capable of achieving desired reflection characteristics cannot be formed, interference light is generated and the like. When a diamond indenter 30 μm to 100 μm in diameter usable for manufacturing the transfer mold is used, practically, the pitches between adjacent concave portions 35a are desirably specified to be 5 μm to 50 μm .

[0090] The manufacturing method for forming this base material 35 is not specifically limited, and manufacture can be performed, for example, as described below.

[0091] A coating of a photosensitive resin solution, for example, an acryl-based resist, is applied on the third phase difference plate 13 so as to form a photosensitive resin layer, a transfer mold provided with a concave and convex surface having the shape of concavities and convexities is pressed against this photosensitive resin layer and, therefore, the shape of the concave and convex surface of the transfer mold is transferred to the photosensitive resin layer.

[0092] This transfer mold can be manufactured in such a manner that a diamond indenter is pressed against the surface of a flat plate-shaped matrix base material which is made of brass, stainless steel, tool steel, or the like and which has a flat surface so as to form a predetermined surface shape and to manufacture a matrix for transfer mold and, thereafter, the shape is molded in a material, for example, silicone resin, using this matrix for transfer mold. This transfer mold is in the shape of concavities and convexities which is the reverse of the surface shape of the plurality of concave portions 35a shown in Fig. 7.

[0093] Subsequently, a light beam, for example, an ultraviolet ray (g, h, and i rays), radiates from the back surface side of the side, on which the photosensitive resin layer has been formed, of the third phase difference plate 13 in order to cure the photosensitive resin layer and, furthermore, the photosensitive resin layer is baked by a heating device, for example, a furnace and a hot plate. Consequently, the base material 35 made of the photosensitive resin layer including the plurality of concave portions 35a on the surface is formed.

[0094] The metal reflection film 36 is placed in order to reflect and scatter the light incident upon the liquid crystal layer 30 and, therefore, to achieve well-lighted display, and is formed on the base material 35. Preferably, a metal material, for example, Al and Ag, having a high reflectance is used as this metal reflection film 36, and these metal materials can be formed by a film making method, for example, sputtering and vacuum evaporation.

[0095] The film thickness of the metal reflection film 36 is preferably within the range of 5 to 50 nm. This is because when the film thickness is smaller than 5 nm, since the reflectance of light by the metal reflection film 36 is excessively small, display in the reflective mode becomes dark, and when the thickness is larger than 50 nm, the translucency of the metal reflection film 36 is reduced and, therefore, display in the transmissive mode becomes dark. (In the present specification, each range indicated using "to" represents "or more, but or less". Therefore, the aforementioned 5 to 50 nm represents 5 nm or more, but 50 nm or less.)

[0096] The film thickness of the metal reflection film 36 is more preferably within the range of 8 to 20 nm. When the film thickness of the metal reflection film 36 is specified to be within such a range, since display in the transmissive mode can be well-lighted, difference in brightness of the display between in the transmissive mode and the reflective mode can be reduced. Consequently, easiness on the eyes of the display can be improved in the use while the aforementioned two operation modes are switched.

[0097] The film thickness of the metal reflection film 36 is most preferably within the range of 8 to 10 nm (that is, 9 nm \pm 1 nm). When the film thickness is set within such a range, the brightness in the reflective mode can be maintained and, in addition, remarkably superior brightness can be realized in the transmissive mode.

[0098] The value of retardation (Δn_{LC}) that is the product of the double refractive index (Δn_{LC}) of the aforementioned liquid crystal cell 1 and the thickness d of the liquid crystal cell 1 is set within the range of 600 nm to 800 nm (measurement wavelength 589 nm). When the Δn_{LC} is outside the aforementioned range, the white display is darkened and

the contrast is reduced.

[0099] It is relatively preferable that the aforementioned Δn_{LC} is preferably set within the range of 690 nm to 705 nm, and more preferably, is set at 700 nm from the viewpoint that excellent black-and-white display having high contrast can be achieved.

[0100] As described above, the semitransparent reflective liquid crystal display device 101 according to the present embodiment is configured in order that the light passes through the third phase difference plate 13 and the second polarizing plate 16 only in the case of the transmissive mode. Consequently, the first and second phase difference plates 14 and 15 and the first polarizing plate 17 involve in the operation of the liquid crystal display device in both the transmissive mode and reflective mode although the third phase difference plate 13 and second polarizing plate 16 involve only in the transmissive mode.

[0101] The aforementioned first, second, and third phase difference plate 14, 15, and 13 are made of a monoaxially or biaxially oriented film of, for example, polyvinyl alcohol and polycarbonate, and the direction of the orientation becomes a lagging phase axis.

[0102] The Δn_{RF1} of the first phase difference plate 14 is set within the range of 100 nm to 200 nm (measurement wavelength 589 nm). When the Δn_{RF1} is outside the aforementioned range, high contrast ratio or high luminance cannot be achieved in the transmissive mode and the reflective mode. It is especially preferable that the aforementioned Δn_{RF1} is set at 170 nm.

[0103] As shown in Fig. 3 to Fig. 6, an angle (ϕ_{RF1}), which a lagging phase axis β of the first phase difference plate 14 forms with respect to the aforementioned normal direction X, is set at 60 degrees to 100 degrees counterclockwise when viewed from the incident side of the light. When the lagging phase axis β is not set within the aforementioned range, high contrast ratio or high luminance cannot be achieved in the transmissive mode and the reflective mode. It is preferable that the angle (ϕ_{RF1}), which the aforementioned lagging phase axis β forms with respect to the aforementioned normal direction X, is set at 80 degrees counterclockwise when viewed from the incident side of the light from the viewpoint that high contrast ratio or high luminance can be achieved in the transmissive mode and the reflective mode.

[0104] The Δn_{RF2} of the second phase difference plate 15 is set within the range of 300 nm to 500 nm (measurement wavelength 589 nm). When the Δn_{RF2} is outside the aforementioned range, high contrast ratio or high luminance cannot be achieved in the transmissive mode and the reflective mode. It is especially preferable that the aforementioned Δn_{RF2} is set at 425 nm. As shown in Fig. 3 to Fig. 6, an angle (ϕ_{RF2}), which a lagging phase axis γ of the second phase difference plate 15 forms with respect to the aforementioned normal direction X, is set at 90 degrees to 140 degrees counterclockwise when viewed from the incident side of the light. When the lagging phase axis γ is not set within the aforementioned range, high contrast ratio or high luminance cannot be achieved in the transmissive mode and the reflective mode. It is preferable that the angle (ϕ_{RF2}), which the aforementioned lagging phase axis γ forms with respect to the aforementioned normal direction X, is set at 113 degrees counterclockwise when viewed from the incident side of the light from the viewpoint that high contrast ratio or high luminance can be achieved in the transmissive mode and the reflective mode.

[0105] Regarding the third phase difference plate 13 and second polarizing plate 16, since the optimum ranges of the Δn_{RF3} and the lagging phase axis δ of the third phase difference plate 13 and the optimum range of the absorption axis ε of the second polarizing plate 16 are different between the case where a liquid crystal display device having well-lighted white display and superior luminance in the transmissive mode is configured and the case where a liquid crystal display device exhibiting excellent black-and-white display and high contrast ratio in the transmissive mode is configured, each case will be described separately.

[0106] In the case where the liquid crystal display device having well-lighted white display and superior luminance is configured, as shown in Fig. 3 and Fig. 4, it is preferable that the Δn_{RF3} of the third phase difference plate 13 is set within the range of 132.5 nm to 142.5 nm (measurement wavelength 589 nm). When the Δn_{RF3} is outside the aforementioned range, well-lighted white display with high luminance cannot be achieved in the transmissive mode. In particular, it is more preferable that the Δn_{RF3} is set at 137.5 nm. As shown in Fig. 3 and Fig. 4, an angle (ϕ_{RF3}), which a lagging phase axis δ of the third phase difference plate 13 forms with respect to the aforementioned normal direction X, is preferably set at 80 degrees to 100 degrees counterclockwise when viewed from the incident side of the light. When the lagging phase axis δ is not set within the aforementioned range, well-lighted white display with high luminance cannot be achieved in the transmissive mode. It is preferable that the angle (ϕ_{RF3}), which the aforementioned lagging phase axis δ forms with respect to the aforementioned normal direction X, is set at 90 degrees counterclockwise when viewed from the incident side of the light from the viewpoint that further excellent white display can be achieved.

[0107] Furthermore, as shown in Fig. 3 and Fig. 4, an angle (ϕ_{pol2}), which an absorption axis ε of the second polarizing plate 16 forms with respect to the aforementioned normal direction X, is preferably set at 23 degrees to 43 degrees counterclockwise when viewed from the incident side of the light.

[0108] When the absorption axis ε of the second polarizing plate 16 is not set within the aforementioned range, excellent white display with high luminance cannot be achieved in the transmissive mode. It is preferable that the angle

($\phi_{\text{pol}2}$), which the absorption axis ε forms with respect to the aforementioned normal direction X, is set at 33 degrees counterclockwise when viewed from the incident side of the light from the viewpoint that excellent white display with high luminance can be achieved.

[0109] In the case where the liquid crystal display device exhibiting high contrast ratio is configured, as shown in Fig. 5 and Fig. 6, it is preferable that the $\Delta n_{\text{RF}3}$ of the third phase difference plate 13 is set within the range of 120 nm to 130 nm (measurement wavelength 589 nm). When the $\Delta n_{\text{RF}3}$ is outside the aforementioned range, excellent black-and-white display with high contrast ratio cannot be achieved in the transmissive mode. In particular, it is more preferable that the $\Delta n_{\text{RF}3}$ is set at 125 nm. As shown in Fig. 5 and Fig. 6, the angle ($\phi_{\text{RF}3}$), which the lagging phase axis δ of the third phase difference plate 13 forms with respect to the aforementioned normal direction X, is preferably set at 48 degrees to 68 degrees counterclockwise when viewed from the incident side of the light. When the lagging phase axis δ is not set within the aforementioned range, excellent black-and-white display with high contrast ratio cannot be achieved in the transmissive mode. It is preferable that the angle ($\phi_{\text{RF}3}$), which the aforementioned lagging phase axis δ forms with respect to the aforementioned normal direction X, is set at 58 degrees counterclockwise when viewed from the incident side of the light from the viewpoint that further excellent black-and-white display with further high contrast ratio can be achieved.

[0110] Furthermore, as shown in Fig. 5 and Fig. 6, the angle ($\phi_{\text{pol}2}$), which the absorption axis ε of the second polarizing plate 16 forms with respect to the aforementioned normal direction X, is preferably set at 3 degrees to 23 degrees counterclockwise when viewed from the incident side of the light.

[0111] When the absorption axis ε of the second polarizing plate 16 is not set within the aforementioned range, excellent black-and-white display with high contrast ratio cannot be achieved in the transmissive mode. It is preferable that the angle ($\phi_{\text{pol}2}$), which the absorption axis ε forms with respect to the aforementioned normal direction X, is set at 13 degrees counterclockwise when viewed from the incident side of the light from the viewpoint that further excellent black-and-white display with further high contrast ratio can be achieved.

[0112] It is preferable that the N_z coefficient represented by the aforementioned Formula (1) of the first phase difference plate 14 is set within the range of -0.5 to 2.0, and the N_z coefficient represented by the aforementioned Formula (1) of the second phase difference plate 15 is set within the range of -0.5 to 2.0 from the viewpoint that the range, in which contrast is excellent, is extended in the vertical and horizontal directions of the display surface 105 shown in Fig. 1 and, therefore, the one having a wide viewing angle in the vertical and horizontal directions of the display surface 105 and superior visual angle characteristic can be achieved.

[0113] It is more preferable that the N_z coefficient represented by the aforementioned Formula (1) of the first phase difference plate 14 is set at 0.5, and the N_z coefficient represented by the aforementioned Formula (1) of the second phase difference plate 15 is set at 0.3 from the viewpoint that the range, in which contrast is excellent, is further extended in the vertical and horizontal directions of the display surface and, therefore, the viewing angle is further increased in the vertical and horizontal directions of the display surface, and further superior visual angle characteristic can be achieved.

[0114] Furthermore, as shown in Fig. 3 to Fig. 6, an angle ($\phi_{\text{pol}1}$), which an absorption axis α of the first polarizing plate 17 forms with respect to the aforementioned normal direction X, is preferably set at 20 degrees to 70 degrees or 110 degrees to 160 degrees counterclockwise when viewed from the incident side of the light.

[0115] When the absorption axis α of the first polarizing plate 17 is not set within the aforementioned range, high contrast ratio or high luminance cannot be achieved in the transmissive mode and in the reflective mode. It is more preferable that the angle ($\phi_{\text{pol}1}$), which the absorption axis α forms with respect to the aforementioned normal direction X, is set at 42 degrees counterclockwise when viewed from the incident side of the light from the viewpoint that high contrast ratio or high luminance can be achieved.

[0116] In the semitransparent reflective liquid crystal display device 101 according to the present embodiment, since the second polarizing plate 16 is placed on the external side of the metal reflection film 36 having a film thickness of 5 to 50 nm, in the reflective mode, the incident light is reflected by the metal reflection film 36 and does not pass through the second polarizing plate 16 and, therefore, spectral characteristics are not degraded, the color of the screen can be brought close to white, and the contrast ratio of the screen is improved so that visibility can be improved. In the transmissive mode, since the light emitted from the backlight 106 passes through the third phase difference plate and the second polarizing plate, passes through the metal reflection film 36 as well and furthermore, passes through the liquid crystal layer 34, the first and second phase difference plates 14 and 15, and the first polarizing plate 17, the light display (white display) is lightened while the dark display (black display) is darkened and, therefore, the contrast ratio can be improved.

[0117] In particular, since the reflector 30 is configured by forming the metal reflection film 36 on the base material 35 with the concave portions 35a formed on the surface while the metal reflection film includes the plurality of concave surfaces 36a corresponding to the concave portions 35a, condensing function thereof is improved compared to that of the conventional reflection plate including concavities and convexities on the surface and, therefore, the reflectance can be increased. According to this, the light display in the reflective mode is lightened, the luminance and contrast

ratio are improved and, therefore, superior display characteristics can be achieved.

[0118] Regarding the reflective liquid crystal display device 101 according to the present embodiment, the reflector 30 is placed on the external side of the liquid crystal cell 1, and when the reflector 30 is attached on the liquid crystal cell 1, adhesion can be performed at ambient temperature. Consequently, when the liquid crystal cell 1 and the reflector 30 are manufactured separately and, thereafter, the reflector 30 is retrofitted to this liquid crystal cell 1, since thermal stress is not applied to the liquid crystal cell 1 during manufacture of the reflector 30, and agents, etc., used during manufacture of the reflector 30 do not fall on the liquid crystal cell 1, degradation of the liquid crystal cell 1 can be prevented.

[0119] Regarding the semitransparent reflective liquid crystal display device 101 according to the present embodiment, by setting the angle of twisting of the liquid crystal 34 in the direction of the thickness thereof, the Δn_{LC} of the liquid crystal in the liquid crystal layer 34, the angle (ϕ_{RF1}) which the lagging phase axis β of the first phase difference plate 14 forms with respect to the aforementioned normal direction X, the Δn_{RF1} of the first phase difference plate 14, the angle (ϕ_{RF2}) which the lagging phase axis γ of the second phase difference plate 15 forms with respect to the aforementioned normal direction X, the Δn_{RF2} of the second phase difference plate 15, the angle (ϕ_{RF3}) which the lagging phase axis δ of the third phase difference plate 13 forms with respect to the aforementioned normal direction X, the Δn_{RF3} of the third phase difference plate 13, the angle (ϕ_{pol1}) which the absorption axis α of the first polarizing plate 17 forms with respect to the aforementioned normal direction X, and the angle (ϕ_{pol2}) which the absorption axis ϵ of the second polarizing plate 16 forms with respect to the aforementioned normal direction X within the aforementioned preferable range, the white display (light display) becomes further well-lighted, and the one having further high contrast can be achieved.

[0120] By setting the N_z coefficients represented by the aforementioned Formula (1) of the first and second phase difference plates 14 and 15 within the aforementioned preferable range, the range, in which contrast is excellent, is extended in the vertical and horizontal directions of the display surface and, therefore, the viewing angle is increased in the vertical and horizontal directions of the display surface, and the one having superior visual angle characteristic can be achieved.

[0121] Regarding the liquid crystal display device according to the present embodiment, the case where the display surface 105 has been landscape-oriented has been described. However, it may be portrait-oriented.

[0122] The case where the topcoat 28 has been interposed between the upper orientation film 26 and the segment electrode 24 has been described. However, the topcoat 28 is not necessarily placed, and is placed appropriately in accordance with the sort of the liquid crystal display device and required characteristics.

[0123] Regarding the liquid crystal display device according to the present embodiment, the black-and-white display type liquid crystal display device has been described. However, a color filter may be placed between the common electrode 23 and the lower glass substrate 12 and, therefore, a semitransparent reflective color liquid crystal display device may be configured. In that case, a first overcoat may be interposed between the common electrode 23 and the color filter in order to flattening the concavities and convexities due to the color filter.

[0124] Regarding the semitransparent reflective liquid crystal display device 101 according to the present embodiment, the case where as the reflector 30, the one provided with the metal reflection film 36, in which the shape of the concave portion 36a is a symmetrical shape constituting a part of a sphere, has been used has been described. However, a reflector 130, in which the shape of the concave portion 35a of the base material 35 is an asymmetric shape, as shown in Fig. 8 to Fig. 11, may be used instead of this reflector 30.

[0125] The reflector 130 shown in Fig. 8 is configured, for example, by forming a metal reflection film having a film thickness of 5 to 50 nm, although not shown in the drawing, on a base material 135, in which a plurality of concave portions 135a₁, 135a₂, 135a₃, and so forth (generally referred to as 135a) are formed adjacently to each other on a random basis on the surface S (reference plane) of a flat plate by means of an evaporation method, etc.

[0126] Figs. 9 to 11 show an inner surface shape of the concave portion 135a. Fig. 9 is a perspective view of the concave portion 135a, Fig. 10 is a sectional view of the longitudinal section X of the concave portion 135a, and Fig. 11 is a sectional view of the longitudinal section Y orthogonal to the longitudinal section X.

[0127] As shown in Fig. 10, the inner surface shape of the longitudinal section X of the concave portion 135a is composed of a first curve A from one periphery portion S1 of the concave portion 135a to the deepest point D and a second curve B from the deepest point D of the concave portion to other periphery portion S2 in succession to this first curve A. In Fig. 10, both the angles of inclination of the downward-sloping first curve A and the upward-sloping second curve B become zero with respect to the base material surface S at the deepest point D and, therefore, these curves are connected gently to each other.

[0128] The angle of inclination of the first curve A with respect to the base material surface S is steeper than the angle of inclination of the second curve B, and the deepest point D is located at the position deviated from the center O of the concave portion 135a in the x direction. That is, the average value of the absolute values of the angles of inclination of the first curve A with respect to the base material surface S is larger than the average value of the absolute values of the angles of inclination of the second curve B with respect to the base material surface S. The average

values of the absolute values of the angles of inclination of the first curve A in the concave portions 135a₁, 135a₂, 135a₃, and so forth with respect to the base material surface S are varied within the range of 2° to 90° on a random basis. The average values of the absolute values of the angles of inclination of the second curve B in the concave portions 135a₁, 135a₂, 135a₃, and so forth with respect to the base material surface S are varied within the range of

1° to 89° on a random basis.

[0129] On the other hand, as shown in Fig. 11, regarding the inner surface shape of the longitudinal section Y of the concave portion 135a, the right and left are nearly equivalent with respect to the center O of the concave portion 135a, and the periphery of the deepest point D is a shallow type curve E having a large curvature radius, that is, nearly linear. The right and left of the shallow type curve E are deep type curves F and G having a small curvature radius. The average values of the absolute values of the angles of inclination of the shallow type curves E in the concave portions 135a₁, 135a₂, 135a₃, and so forth with respect to the base material surface S are mostly 10° or less. The average values of the absolute values of the angles of inclination of the deep type curves F and G in the concave portions 135a₁, 135a₂, 135a₃, and so forth with respect to the base material surface S are also varied on a random basis, and are, for example, 2° to 90°.

[0130] The distance between the deepest point D and the base material surface S forms the depth d of the concave portion 135a, and regarding the concave portions 135a₁, 135a₂, 135a₃, and so forth, respective depths d are within the range of 0.1 μm to 3 μm, and are varied on a random basis.

[0131] In this reflector 30, each longitudinal section X in the concave portions 135a₁, 135a₂, 135a₃, and so forth is in the same direction. Likewise, each longitudinal section Y in the concave portions 135a₁, 135a₂, 135a₃, and so forth is in the same direction. Furthermore, each first curve A is formed in order to orientate unidirectionally. That is, every concave portion is formed in order that the direction of x shown in Fig. 9 and Fig. 10 becomes identical.

[0132] In this reflector 130, since each first curve A is formed in order to orientate unidirectionally, the reflection characteristic thereof deviates from the direction of the specular reflection with respect to the base material surface S as shown in Fig. 12.

[0133] That is, as shown in Fig. 12, the well-lighted display range of reflected light K relative to obliquely incident light J from above the x direction is shifted in the direction shifted toward the H direction with respect to the base material surface S from the direction K₀ of the specular reflection.

[0134] Furthermore, since in the second longitudinal section Y orthogonal to the first longitudinal section X, each is formed in order to include a shallow type curve E having a large curvature radius and deep type curves F and G existing on both sides of the shallow type curve E and having a small curvature radius, the reflectance in the direction of the specular reflection with respect to the base material surface S can be increased.

[0135] Consequently, as shown in Fig. 13, regarding the total reflection characteristic in the first longitudinal section, the reflectance has a peak at the angle of the specular reflection and, in addition, the reflectance in the direction of reflection by the surface in the periphery of the second curve B is increased. That is, the reflection characteristic which ensures adequately the reflected light in the direction of the specular reflection and which concentrates moderately the reflected light in a specified direction can be achieved.

[0136] That is, Fig. 13 shows the relationship between the acceptance angle (θ°) and the brightness (reflectance) when the reflector 130 shown in Fig. 8 to Fig. 11 is radiated with external light at an incident angle of 30°, and the acceptance angle is varied relative to 30°, which is the direction of the specular reflection with respect to the display surface (base material surface), from the position of perpendicular (0°) to 60°. In Fig. 13, the relationship between the acceptance angle and the reflectance of the reflector 30 including sphere-shaped concave portions shown in Fig. 7 is also shown for purposes of comparison.

[0137] As is clear from Fig. 13, the reflector 30 exhibit nearly even reflectance at the acceptance angle within the range of about 15° to about 45°, while regarding the reflector 130, the reflectance has a peak at the angle of 30° which is the angle of the specular reflection with respect to the base material surface S and, in addition, the integral of reflectance within the range of the reflection angle smaller than 30°, which is the angle of the specular reflection, is larger than the integral of reflectance within the range of the reflection angle larger than the angle of the specular reflection. That is, the brightness in the direction of the specular reflection is ensured and, in addition, adequate brightness is achieved in the visual field at an angle in the neighborhood of 20°.

[0138] Fig. 14 is an illustrative diagram showing the use of the semitransparent reflective liquid crystal display device 101 according to the present embodiment provided with the reflector 130. In Fig. 14, for convenience in description, only the first curve A and the second curve B of the reflector 130 are shown in the drawing, and the other constituents are omitted from the drawing.

[0139] Such a semitransparent reflective liquid crystal display device 101 is incorporated in a cellular phone, notebook computer, etc., the x direction up. In this case, usually, the semitransparent reflective liquid crystal display device 101 is placed or held obliquely with respect to the horizontal surface while the x direction is obliquely above as shown in Fig. 14. That is, the first curves A in respective concave portions are placed in order to locate above the second curves B when viewed from the observer during use. In general, the observer looks down at this liquid crystal display device

101 from obliquely above rather than from a horizontal position.

[0140] In this case, the reflected light K of the external light (incident light J) primarily incident from above is reflected at the surface in the periphery of the second curve B, is unlikely to be reflected in the direction toward the feet of the observer, as has been described regarding Fig. 12, and therefore, is reflected primarily in the direction above the direction K_0 of the specular reflection.

[0141] Consequently, the normal observation range of the observer agrees with the well-lighted display range and, therefore, a well-lighted liquid crystal display device can be realized practically.

[Examples]

[0142] The present invention will be further specifically described below using Examples and Comparative examples. However, the present invention is not limited to only these Examples.

(Experiment 1)

[0143] Examinations were performed regarding the display characteristics of the semitransparent reflective liquid crystal display devices according to the embodiments shown in Fig. 1 to Fig. 6 in the reflective mode.

[0144] Herein, PSI-2501 (trade name; manufactured by Chisso Corporation) was used as upper and lower orientation films constituting the liquid crystal cell, and an orientation treatment was performed in order that the twist angle of the liquid crystal became 240 degrees. The angle, which the orientation direction a of the upper orientation film formed with respect to the aforementioned normal direction X, was +330 degrees (-30 degrees) when viewed from the incident side of the light, and the angle, which the orientation direction b of the lower orientation film formed with respect to the aforementioned normal direction X, was +30 degrees when viewed from the incident side of the light. AP-4365LF (trade name; manufactured by Chisso Petrochemical Corporation) was used as the liquid crystal in the liquid crystal layer. NRZ-170 (trade name; manufactured by Nitto Denko Corporation, material: polycarbonate) was used as the first phase difference plate, NRZ-450 (trade name; manufactured by Nitto Denko Corporation, material: polycarbonate) was used as the second phase difference plate, and NPF-SEG1425DU (trade name; manufactured by Nitto Denko Corporation) was used as the first polarizing plate.

[0145] An acryl-based photosensitive resin base material (resin base material for reflector), in which a concave and convex surface was formed on the surface by a silicone mold including concave and convex portions, was radiated with an ultraviolet ray and was cured, an Al film (metal reflection film) 25 nm in thickness was formed on this photosensitive resin base material, and the resulting one was used as the reflector. The concave and convex surface on the surface of this reflector was provided with a metal thin film including concave surfaces in the shape constituting a part of a sphere as shown in Fig. 7.

[0146] Each of the Δn_{LC} (measurement wavelength 589 nm) of the liquid crystal cell, the Δn_{RF1} of the first phase difference plate, the angle (ϕ_{RF1}) which the lagging phase axis β of the first phase difference plate formed with respect to the aforementioned normal direction X, the Δn_{RF2} of the second phase difference plate, the angle (ϕ_{RF2}) which the lagging phase axis γ of the second phase difference plate formed with respect to the aforementioned normal direction X, and the angle (ϕ_{pol1}) which the absorption axis α of the first polarizing plate formed with respect to the aforementioned normal direction X was set as shown in the following Table 1 (Sample Nos. 1 to 17).

[0147] The display characteristics of the reflective liquid crystal display device of Sample Nos. 1 to 17 were examined as described below. Herein, regarding the display characteristics, a light source, the first polarizing plate, the second phase difference plate, the first phase difference plate, the liquid crystal cell, and the reflector were arranged in that order, light was entered into the liquid crystal cell from the direction at an azimuth angle of 90 degrees counterclockwise and the direction at -30 degrees from the Z direction (the normal direction) shown in Fig. 3 and Fig. 4, and the value of Y (brightness) and the contrast in the white display condition (applied voltage 2.20 V) of a normally black display system (N/B) in the case where the reflected light in the Z direction was received at an acceptance angle of 0 degree were evaluated. Regarding the evaluation criteria, when the Y value exceeded 40, the brightness was evaluated as excellent, and when the contrast exceeded 50, the contrast was evaluated as excellent. The results are collectively shown in the following Table 1 and Table 2.

[Table 1]

Sample No.	Liquid crystal layer		First phase difference plate		Second phase difference plate		First polarizing plate	Y	Contrast
	Δn_{LC} (nm)	Δn_{RF1} (nm)	ϕ_{RF1} (°)	Δn_{RF2} (nm)	ϕ_{RF2} (°)	ϕ_{pol1} (°)			
1	630	175	80.0	330	122.0	62.0	40.71	77.2	
2	650	175	80.0	330	122.0	62.0	43.03	219.8	
3	670	175	80.0	340	120.0	54.0	44.71	53.2	
4	700	131	68.0	377	99.0	24.5	43.78	93.5	
5	720	140	70.0	410	100.0	25.0	46.44	111.3	
6	720	160	80.0	370	114.0	40.0	47.31	51.0	
7	720	180	90.0	330	130.0	65.0	47.17	59.2	
8	740	170	85.0	370	124.0	53.0	46.66	57.3	
9	760	170	75.0	450	105.0	34.0	47.10	64.4	
10	780	170	75.0	450	105.0	34.0	44.07	86.6	

[Table 2]

Sample No.	Liquid crystal layer		First phase difference plate		Second phase difference plate		First polarizing plate	Y	Contrast
	Δn_{LC} (nm)	Δn_{RF1} (nm)	ϕ_{RF1} (°)	Δn_{RF2} (nm)	ϕ_{RF2} (°)	ϕ_{pol1} (°)			
11	580	175	80.0	330	122.0	62.0	41.2	8.3	
12	630	210	80.0	330	122.0	62.0	38.4	9.1	
13	630	175	55.0	330	122.0	62.0	46.3	1.8	
14	630	175	80.0	290	122.0	62.0	31.0	32.4	
15	630	175	80.0	330	145.0	62.0	43.5	1.2	
16	630	175	80.0	330	122.0	15.0	47.4	1.6	
17	630	175	80.0	330	122.0	75.0	44.2	5.5	

[0148] As is clear from the results shown in the aforementioned Table 1 and Table 2, regarding those in Sample Nos. 11 to 17, wherein any one of the Δn_{LC} of the liquid crystal cell, the Δn_{RF1} of the first phase difference plate, the angle (ϕ_{RF1}) which the lagging phase axis β of the first phase difference plate formed with respect to the aforementioned normal direction X, the Δn_{RF2} of the second phase difference plate, the angle (ϕ_{RF2}) which the lagging phase axis γ of the second phase difference plate formed with respect to the aforementioned normal direction X, and the angle (ϕ_{pol1}) which the absorption axis α of the first polarizing plate formed with respect to the aforementioned normal direction

X was not set within the preferable range, in the reflective mode, the contrast was less than 33, or the Y value in the white display condition was less than 39 and, therefore, the brightness was reduced.

[0149] On the other hand, regarding those in Sample Nos. 1 to 10, wherein all the Δn_{LC} of the liquid crystal cell, the Δn_{RF1} of the first phase difference plate, the angle (ϕ_{RF1}) which the lagging phase axis β of the first phase difference plate forms with respect to the aforementioned normal direction X, the Δn_{RF2} of the second phase difference plate, the angle (ϕ_{RF2}) which the lagging phase axis γ of the second phase difference plate forms with respect to the aforementioned normal direction X, and the angle (ϕ_{pol1}) which the absorption axis α of the first polarizing plate forms with respect to the aforementioned normal direction X are set within the preferable range, in the reflective mode, the contrast exceeds 51, furthermore, the Y value in the white display condition exceeds 40 and, therefore, it is well-lighted. Consequently, it is clear that the white display is well-lighted, the contrast is high, and, therefore, superior display characteristics are achieved.

In particular, regarding those in Sample Nos. 2 and 5, well-lighted white display and high contrast of 110 or more have been achieved.

(Experiment 2)

[0150] As an Example, the display characteristics of the semitransparent reflective liquid crystal display device of Sample No. 4 were examined as described below.

[0151] Herein, regarding the display characteristics, light (diameter 22 mm and luminous flux 500 lux) from a light source was entered into the liquid crystal cell from the direction at an azimuth angle of 330 degrees and the direction at 15 degrees from the Z direction (the direction orthogonal to respective surfaces on the incident side of the liquid crystal cell 1, the first phase difference plate 14, the second phase difference plate 15, and the first polarizing plate 17) shown in Fig. 3, and the reflectance and the contrast were examined. The results thereof are shown in Fig. 15 and Fig. 16.

[0152] Fig. 15 is a diagram showing the relationship between the observation angle (acceptance angle) and the reflectance when light is entered at 15 degrees into the semitransparent reflective liquid crystal display device in the Example. Fig. 16 is a diagram showing the relationship between the observation angle (acceptance angle) and the contrast when light is entered at 15 degrees into the semitransparent reflective liquid crystal display device in the Example.

[0153] As Comparative example, the display characteristics of the semitransparent reflective liquid crystal display device of the Comparative example shown in Fig. 19 and Fig. 20 were examined.

[0154] Ap-4268LA (trade name; manufactured by Chisso Petrochemical Corporation) was used as the liquid crystal in the semitransparent reflective liquid crystal display device of the Comparative example. The Δn (the product of the double refractive index Δn of the liquid crystal in the liquid crystal layer and the thickness d of the liquid crystal layer) of the liquid crystal cell was 860 nm (measurement wavelength 589 nm). NRF-430 (trade name; manufactured by Nitto Denko Corporation, material: polycarbonate) was used as the first phase difference plate, NRF-430 (trade name; manufactured by Nitto Denko Corporation, material: polycarbonate) was used as the second phase difference plate. NPF-EG-1225DU (trade name; manufactured by Nitto Denko Corporation) was used as the upper polarizing plate (first polarizing plate). NPF-EG-1225DU (trade name; manufactured by Nitto Denko Corporation) was used as the lower polarizing plate (second polarizing plate). A concave and convex surface was formed on the surface of a resin film by a sandblast treatment, an Al film on the order of 26 to 28 nm in thickness (the total light transmittance (T) of the Al film = 10%) was formed on this concave and convex surface by an evaporation method, and the resulting one was used as the reflector. The other materials used were similar to those used in the aforementioned Example.

[0155] Regarding the semitransparent reflective liquid crystal display device in this Comparative example, the Δn of the liquid crystal cell was set at 860 nm, the retardation of the first phase difference plate was set at 430 nm, the angle which the lagging phase axis of the first phase difference plate formed with respect to the aforementioned normal direction X was set at 70 degrees counterclockwise when viewed from the incident side of the light, the retardation of the second phase difference plate was set at 430 nm, the angle which the lagging phase axis of the second phase difference plate formed with respect to the aforementioned normal direction X was set at 25 degrees counterclockwise when viewed from the incident side of the light, the angle which the absorption axis of the first polarizing plate (upper polarizing plate) formed with respect to the aforementioned normal direction X was set at 5 degrees counterclockwise when viewed from the incident side of the light, and the angle which the absorption axis of the second polarizing plate (lower polarizing plate) formed with respect to the aforementioned normal direction X was set at 5 degrees counterclockwise when viewed from the incident side of the light.

[0156] In a manner similar to that in the aforementioned Example, the relationship between the observation angle (acceptance angle) and the reflectance when light was entered at 15 degrees and the relationship between the observation angle (acceptance angle) and the contrast when light was entered at 15 degrees were examined. The results thereof are shown in Fig. 17 and Fig. 18.

[0157] Fig. 17 is a diagram showing the relationship between the observation angle (acceptance angle) and the reflectance when light was entered at 15 degrees into the semitransparent reflective liquid crystal display device in the Comparative example, and Fig. 18 is a diagram showing the relationship between the observation angle (acceptance angle) and the contrast when light was entered at 15 degrees into the semitransparent reflective liquid crystal display device in the Comparative example.

[0158] When the results shown in Fig. 15 and Fig. 17 are compared, it is clear that the range, in which the reflectance in the light display condition is high, of the semitransparent reflective liquid crystal display device in the Example is wider than that of the semitransparent reflective liquid crystal display device in the Comparative example. In particular, it is clear that when the observation angle is 0° to 12° and 16° to 34°, the reflectance of the semitransparent reflective liquid crystal display device in the Example is higher than that of the semitransparent reflective liquid crystal display device in the Comparative example.

[0159] When the results shown in Fig. 16 and Fig. 18 are compared, it is clear that the range, in which the contrast of display surface is large, of the semitransparent reflective liquid crystal display device in the Example is wider than that in the Comparative example. In particular, it is clear that when the observation angle is 0° to 10° and 18° to 46°, the contrast of the semitransparent reflective liquid crystal display device in the Example is higher than that of the semitransparent reflective liquid crystal display device in the Comparative example. Consequently, it has been made clear that according to the semitransparent reflective liquid crystal display device in the Example, a display surface having a wide viewing angle has been able to achieve, and the visual angle dependence has been able to improve.

(Experiment 3)

[0160] Examinations were performed regarding the display characteristics of the semitransparent reflective liquid crystal display devices according to the embodiments shown in Fig. 1 to Fig. 6 in the transmissive mode.

[0161] Herein, PSI-2501 (trade name; manufactured by Chisso Corporation) was used as upper and lower orientation films constituting the liquid crystal cell, and an orientation treatment was performed in order that the twist angle of the liquid crystal became 240 degrees. The angle, which the orientation direction a of the upper orientation film formed with respect to the aforementioned normal direction X, was +330 degrees (-30 degrees) when viewed from the incident side of the light, and the angle, which the orientation direction b of the lower orientation film formed with respect to the aforementioned normal direction X, was +30 degrees when viewed from the incident side of the light. AP-4365LF (trade name; manufactured by Chisso Petrochemical Corporation) was used as the liquid crystal in the liquid crystal layer. NRZ-RF01A (trade name; manufactured by Nitto Denko Corporation, material: polycarbonate) was used as the first and second phase difference plates, NRF-9F01A (trade name; manufactured by Nitto Denko Corporation, material: polycarbonate) was used as the third phase difference plate, NPF-SEG1224DU (trade name; manufactured by Nitto Denko Corporation) was used as the first polarizing plate, and NPF-SEG1224DU (trade name; manufactured by Nitto Denko Corporation) was used as the second polarizing plate.

[0162] An acryl-based photosensitive resin base material (resin base material for reflector), in which a concave and convex surface was formed on the surface by a silicone mold including concave and convex portions, was radiated with an ultraviolet ray and was cured, an Al film (metal reflection film) 25 nm in thickness was formed on this photosensitive resin base material, and the resulting one was used as the reflector. The concave and convex surface on the surface of this reflector was provided with a metal thin film including concave surfaces in the shape constituting a part of a sphere, as shown in Fig. 7.

[0163] The Δn_{LC} (measurement wavelength 589 nm) of the liquid crystal cell was set at 700 nm, the Δn_{RF1} of the first phase difference plate was set at 170 nm, the angle (ϕ_{RF1}), which the lagging phase axis β of the first phase difference plate formed with respect to the aforementioned normal direction X, was set at 80 degrees, the Δn_{RF2} of the second phase difference plate was set at 425 nm, the angle (ϕ_{RF2}), which the lagging phase axis γ of the second phase difference plate formed with respect to the aforementioned normal direction X, was set at 113 degrees, the angle (ϕ_{pol1}), which the absorption axis α of the first polarizing plate formed with respect to the aforementioned normal direction X, was set at 42 degrees.

[0164] Each of the Δn_{RF3} of the third phase difference plate, the angle (ϕ_{RF3}), which the lagging phase axis δ of the third phase difference plate formed with respect to the aforementioned normal direction X, and the angle (ϕ_{pol2}), which the absorption axis ϵ of the second polarizing plate formed with respect to the normal direction X, was set as shown in the following Table 3 (Sample Nos. 18 to 34).

[0165] The display characteristics of the semitransparent reflective liquid crystal display devices of Sample Nos. 18 to 34 were examined as described below. Herein, regarding the display characteristics, the first polarizing plate, the second phase difference plate, the first phase difference plate, the liquid crystal cell, the reflector, the third phase difference plate, the second polarizing plate, and the light source were arranged in that order, light was entered into the liquid crystal cell from the direction at an azimuth angle of 20 degrees counterclockwise and the direction opposite to the Z direction (the normal direction) shown in Fig. 3 to Fig. 6, and the value of W (brightness) in the white display

condition (applied voltage 2.20 V) of a normally black display system (N/B), the value of B (brightness) in the black display condition (applied voltage 25 V), and the contrast in the case where the transmitted light in the Z direction was received at an acceptance angle of 0 degree were evaluated. The results are shown in the following Table 3.

[Table 3]

sample No.	Third phase difference plate		Second polarizing plate $\phi_{pol2} (^{\circ})$	W	B	Contrast
	$\Delta n_{RF3} (nm)$	$\phi_{RF3} (^{\circ})$				
18	140	76	34	15.60	2.260	6.90
19	133	58	13	18.90	1.010	18.71
20	133	58	13	17.50	0.990	17.68
21	137.5	90	33	27.80	1.700	16.35
22	133	58	13	19.85	0.814	24.39
23	133	58	13	18.40	0.850	21.65
24	133	29	-10	22.80	1.390	16.40
25	120	58	13	15.30	1.430	10.70
26	125	58	13	20.67	0.834	24.78
27	125	72	13	27.00	1.350	20.00
28	125	65	13	22.30	1.010	22.08
29	125	62	13	31.15	0.920	22.99
30	125	60	13	20.81	0.890	23.38
31	125	58	13	20.81	0.840	24.77
32	125	58	13	21.44	0.940	22.81
33	125	54	13	22.20	0.990	22.42
34	125	50	13	23.30	1.090	21.38

[0166] Among Samples shown in Table 3, regarding Samples 18 to 24, improvement of the luminance of the liquid crystal display device was intended by primarily increasing the brightness of the white display. Among Samples 18 to 24, especially, regarding Sample 21, the brightness (W) of the white display reaches 27.8 and, therefore, the liquid crystal display device having extremely high luminance has been achieved. Regarding the other Samples 18 to 20 and 22 to 24, it is clear that each parameter of the Δn_{RF3} and ϕ_{RF3} of the third phase difference plate and (ϕ_{pol2}) of the second polarizing plate is outside the optimum range for increasing the luminance and, therefore, inadequate values are exhibited with respect to the brightness (W) of the white display.

[0167] Among Samples shown in Table 3, regarding Samples 25 to 34, improvement of the contrast was intended by primarily increasing the difference between the brightness of the white display and the brightness of the black display.

Among Samples 25 to 34, especially, regarding Samples 26 and 31, the contrast ratios reach 24.77 to 24.78 and, therefore, extremely high contrast ratios have been achieved. Samples 27 to 30 and 32 to 34 also exhibit contrast ratios of 20 or more and, therefore, it is clear that excellent contrast ratios have been achieved.

[0168] On the other hand, regarding Sample 25, it is clear that each parameter of the Δn_{RF3} and ϕ_{RF3} of the third phase difference plate and (ϕ_{pol2}) of the second polarizing plate is outside the optimum range for increasing the contrast and, therefore, an inadequate value is exhibited with respect to the contrast.

(Experiment 4)

[0169] An organic film having a film thickness of 2 μm made of a photosensitive resin was formed on the third phase difference plate made of polycarbonate, an aluminum film of 9 nm is formed as the metal reflection film on this organic film, an adhesive layer of 25 μm covering this organic film and the metal reflection film was laminated, the lower glass substrate was attached thereon, the electrode layer and the lower orientation film were further laminated sequentially on the lower glass substrate and, therefore, a substrate for a liquid crystal device was formed. The surface shape of the aforementioned organic film was made to be the shape in which a plurality of concave portions, each having an inner surface constituting a part of a sphere, were formed on the surface while being controlled to have depths of 0.6 μm to 1.2 μm , distribution of inclination of inner surfaces of -8 degrees to 8 degrees, and pitches of 26.5 μm to 36.5 μm .

[0170] This substrate for the liquid crystal device and the upper glass substrate provided with an electrode layer, an orientation film, etc., prepared separately were faced each other, and were integrated by adhesion with a sealing member so as to produce a liquid crystal cell.

[0171] Subsequently, the first to third phase difference plates, the first and second polarizing plates, and a backlight were attached to this liquid crystal cell and, therefore, a semitransparent reflective liquid crystal display device of Sample 36 as shown in Fig. 1 was manufactured.

[0172] Furthermore, semitransparent reflective liquid crystal display devices (Samples 37 to 43) having configurations equivalent to that of the aforementioned Sample 36 except that aluminum films having film thicknesses shown in the following table were formed as the metal reflection film were manufactured.

Film thickness of metal reflection film	
Sample 37	10 nm
Sample 38	15 nm
Sample 39	20 nm
Sample 40	30 nm
Sample 41	7.5 nm
Sample 42	32.5 nm
Sample 43	100 nm

[0173] Regarding each of the aforementioned semitransparent reflective liquid crystal display device of Samples 36 to 43, the brightness of the display was evaluated in the reflective mode without lighting up of the backlight and in the transmissive mode with lighting up of the backlight. An evaluation system of classification into four categories shown in the following table was adopted, and evaluations were performed regarding three items including each of the reflective mode and transmissive mode and, in addition, the total evaluation derived from these evaluation results.

(Evaluation)

[0174]

- A extremely well-lighted and easy on the eyes
- B well-lighted and easy on the eyes
- C slightly dark
- D brightness is inadequate, but display can be visually identified

[0175] The evaluation results of each Sample are shown in the following table. As shown in the table, the liquid crystal display devices of Samples 36 and 37 exhibited excellent brightness and the displays were easy on the eyes by a large degree in both reflective mode and transmissive mode. The liquid crystal display devices of Samples 38 to 40 exhibited brightness slightly inferior to those of Samples 36 and 37 in the transmissive mode, and accompanying that, reduction in visibility was observed. Regarding the liquid crystal display device of Sample 40 having the reflection

film thickness of 30 nm, there was a difference between the brightness of the display in the transmissive mode and that in the reflective mode and, therefore, although the brightness was adequate for use as the brightness of the display, easiness on the eyes of the display tended to be slightly poor in the use while the transmissive mode and the reflective mode were switched. Regarding the brightness of Samples 38 to 40 in the transmissive mode, the liquid crystal display device of Sample 38 was lightest, that of the Sample 40 was darkest, and that of the Sample 39 exhibited intermediate brightness.

[0176] On the other hand, in the liquid crystal display device of Sample 41, the display was slightly dark in the reflective mode, and in the liquid crystal display device of Sample 42, the display was slightly dark in the reflective mode and, therefore, the displays were clearly not easy on the eyes. Since the liquid crystal display device of Sample 43 hardly transmitted light, the display in the transmissive mode was clearly inferior. It is believed that Samples 41 to 43 were evaluated as poor because the film thicknesses of the metal reflection films were outside the range of 5 to 50 nm.

	Film thickness of metal reflection film	Evaluation in reflective mode	Evaluation in transmissive mode	Total evaluation
Sample 36	9 nm	A	A	A
Sample 37	10 nm	A	A	A
Sample 38	15 nm	A	B	B
Sample 39	20 nm	A	B	B
Sample 40	30 nm	A	B	B
Sample 41	7.5 nm	C	A	C
Sample 42	32.5 nm	A	C	C
Sample 43	100 nm	A	D	D

[0177] As described above in detail, according to the liquid crystal display device of the present invention, since the second polarizing plate is placed outside the reflector including the metal reflection film having a film thickness of 5 to 50 nm, in the reflective mode, the incident light is reflected by the metal reflection film and, therefore, does not pass through the second polarizing plate. Consequently, the spectral characteristic is not degraded, the color of the screen of the liquid crystal display device can be brought close to white, the contrast ratio of the screen is improved and, therefore, the visibility can be improved. In the transmissive mode, since the light emitted from the backlight passes through the third phase difference plate and the second polarizing plate, passes through the metal reflection film as well, and furthermore, passes through the liquid crystal layer, the first and second phase difference plate, and the first polarizing plate, the light display (white display) is lightened while the dark display (black display) is darkened and, therefore, the contrast ratio can be improved.

[0178] In particular, since the reflector is configured by forming the metal reflection film on the base material with concave portions formed on the surface while the metal reflection film includes concave surfaces corresponding to the aforementioned concave portions, the light condensing function is enhanced and, therefore, the reflectance can be increased compared to those in conventional reflection plate including concavities and convexities on the surface. According to this, the light display in the reflective mode is lightened, the luminance and the contrast ratio are improved and, therefore, superior display characteristics can be achieved.

Claims

1. A liquid crystal display device comprising:

- a liquid crystal cell in which a transparent electrode and an orientation film are placed on the inner surface side of one transparent substrate of a pair of transparent substrates facing each other with a liquid crystal layer therebetween in that order from the one transparent substrate side, and a transparent electrode and an orientation film are placed on the inner surface side of the other transparent substrate in that order from the other transparent substrate side;
- first and second phase difference plates and a first polarizing plate formed sequentially on the outer surface side of the other transparent substrate;
- a reflector attached on the outer surface side of the one transparent substrate with an adhesive layer therebetween; and
- a third phase difference plate and a second polarizing plate formed sequentially on the outer surface side of

the one transparent substrate, but on the side farther from the outer surface than is the reflector,

wherein the reflector is configured by forming a metal reflection film on a base material with a plurality of concave portions formed on the surface while the metal reflection film includes a plurality of concave surfaces corresponding to the concave portions, the metal reflection film is attached to the liquid crystal cell in order to face the one transparent substrate side, and the film thickness of the metal reflection film is within the range of 5 to 50 nm.

2. The liquid crystal display device according to Claim 1, wherein:

the liquid crystal layer has a helical structure twisted 240 degrees to 250 degrees in the direction of the thickness thereof, and the retardation (Δn_{LC}) of the liquid crystal cell is 600 nm to 800 nm;

when the orientation direction a of the orientation film on the other transparent substrate side and the orientation direction b of the orientation film on the one transparent substrate side are viewed from the incident side of light, and when the direction, which is a direction between the orientation directions a and b and which passes at an angle half the interior angle formed by the cross-point O of the orientation directions a and b and the orientation directions a and b, is referred to as the normal direction X;

the retardation (Δn_{RF1}) of the first phase difference plate adjacent to the other transparent substrate is 100 nm to 200 nm, and an angle (ϕ_{RF1}), which a lagging phase axis β of the first phase difference plate forms with respect to the normal direction X, is 60 degrees to 100 degrees counterclockwise when viewed from the incident side of the light;

the retardation (Δn_{RF2}) of the second phase difference plate adjacent to the first polarizing plate is 300 nm to 500 nm, and an angle (ϕ_{RF2}), which a lagging phase axis γ of the second phase difference plate forms with respect to the normal direction X, is 90 degrees to 140 degrees counterclockwise when viewed from the incident side of the light;

the retardation (Δn_{RF3}) of the third phase difference plate adjacent to the one transparent substrate is 132.5 nm to 142.5 nm, and an angle (ϕ_{RF3}), which a lagging phase axis δ of the third phase difference plate forms with respect to the normal direction X, is 80 degrees to 110 degrees counterclockwise when viewed from the incident side of the light;

an angle (ϕ_{pol1}), which an absorption axis α of the first polarizing plate forms with respect to the normal direction X, is 20 degrees to 70 degrees or 110 degrees to 160 degrees counterclockwise when viewed from the incident side of the light; and

an angle (ϕ_{pol2}), which an absorption axis ϵ of the second polarizing plate forms with respect to the normal direction X, is set at 23 degrees to 43 degrees counterclockwise when viewed from the incident side of the light.

3. The liquid crystal display device according to Claim 1 or 2, wherein:

the liquid crystal layer has the helical structure twisted 240 degrees in the direction of the thickness thereof, and the retardation (Δn_{LC}) of the liquid crystal cell is 700 nm;

when the orientation direction a of the orientation film on the other transparent substrate side and the orientation direction b of the orientation film on the one transparent substrate side are viewed from the incident side of light, and when the direction, which is the direction between the orientation directions a and b and which passes at the angle half the interior angle formed by the cross-point O of the orientation directions a and b and the orientation directions a and b, is referred to as the normal direction X;

the retardation (Δn_{RF1}) of the first phase difference plate adjacent to the other transparent substrate is 170 nm, and the angle (ϕ_{RF1}), which the lagging phase axis β of the first phase difference plate forms with respect to the normal direction X, is 80 degrees counterclockwise when viewed from the incident side of the light;

the retardation (Δn_{RF2}) of the second phase difference plate adjacent to the first polarizing plate is 425 nm, and the angle (ϕ_{RF2}), which the lagging phase axis γ of the second phase difference plate forms with respect to the normal direction X, is 113 degrees counterclockwise when viewed from the incident side of the light;

the retardation (Δn_{RF3}) of the third phase difference plate adjacent to the one transparent substrate is 137.5 nm, and the angle (ϕ_{RF3}), which the lagging phase axis δ of the third phase difference plate forms with respect to the normal direction X, is 90 degrees counterclockwise when viewed from the incident side of the light;

the angle (ϕ_{pol1}), which the absorption axis α of the first polarizing plate forms with respect to the normal direction X, is 42 degrees counterclockwise when viewed from the incident side of the light; and

the angle (ϕ_{pol2}), which the absorption axis ϵ of the second polarizing plate forms with respect to the normal direction X, is set at 33 degrees counterclockwise when viewed from the incident side of the light.

4. The liquid crystal display device according to any of Claims 1 to 3, wherein:

the liquid crystal layer has the helical structure twisted 240 degrees to 250 degrees in the direction of the thickness thereof, and the retardation (Δn_{LC}) of the liquid crystal cell is 600 nm to 800 nm;
 when the orientation direction a of the orientation film on the other transparent substrate side and the orientation direction b of the orientation film on the one transparent substrate side are viewed from the incident side of light, and when the direction, which is the direction between the orientation directions a and b and which passes at the angle half the interior angle formed by the cross-point O of the orientation directions a and b and the orientation directions a and b, is referred to as the normal direction X;
 the retardation (Δn_{RF1}) of the first phase difference plate adjacent to the other transparent substrate is 100 nm to 200 nm, and the angle (ϕ_{RF1}), which the lagging phase axis β of the first phase difference plate forms with respect to the normal direction X, is 60 degrees to 100 degrees counterclockwise when viewed from the incident side of the light;
 the retardation (Δn_{RF2}) of the second phase difference plate adjacent to the first polarizing plate is 300 nm to 500 nm, and the angle (ϕ_{RF2}), which the lagging phase axis γ of the second phase difference plate forms with respect to the normal direction X, is 90 degrees to 140 degrees counterclockwise when viewed from the incident side of the light;
 the retardation (Δn_{RF3}) of the third phase difference plate adjacent to the one transparent substrate is 120 nm to 130 nm, and the angle (ϕ_{RF3}), which the lagging phase axis δ of the third phase difference plate forms with respect to the normal direction X, is 48 degrees to 68 degrees counterclockwise when viewed from the incident side of the light;
 the angle (ϕ_{pol1}), which the absorption axis α of the first polarizing plate forms with respect to the normal direction X, is 20 degrees to 70 degrees or 110 degrees to 160 degrees counterclockwise when viewed from the incident side of the light; and
 the angle (ϕ_{pol2}), which the absorption axis ϵ of the second polarizing plate forms with respect to the normal direction X, is set at 3 degrees to 23 degrees counterclockwise when viewed from the incident side of the light.

5. The liquid crystal display device according to any of Claims 1 to 4, wherein:

the liquid crystal layer has the helical structure twisted 240 degrees in the direction of the thickness thereof, and the retardation (Δn_{LC}) of the liquid crystal cell is 700 nm;
 when the orientation direction a of the orientation film on the other transparent substrate side and the orientation direction b of the orientation film on the one transparent substrate side are viewed from the incident side of light, and when the direction, which is the direction between the orientation directions a and b and which passes at the angle half the interior angle formed by the cross-point O of the orientation directions a and b and the orientation directions a and b, is referred to as the normal direction X;
 the retardation (Δn_{RF1}) of the first phase difference plate adjacent to the other transparent substrate is 170 nm, and the angle (ϕ_{RF1}), which the lagging phase axis β of the first phase difference plate forms with respect to the normal direction X, is 80 degrees counterclockwise when viewed from the incident side of the light;
 the retardation (Δn_{RF2}) of the second phase difference plate adjacent to the first polarizing plate is 425 nm, and the angle (ϕ_{RF2}), which the lagging phase axis γ of the second phase difference plate forms with respect to the normal direction X, is 113 degrees counterclockwise when viewed from the incident side of the light;
 the retardation (Δn_{RF3}) of the third phase difference plate adjacent to the one transparent substrate is 125 nm, and the angle (ϕ_{RF3}), which the lagging phase axis δ of the third phase difference plate forms with respect to the normal direction X, is 58 degrees counterclockwise when viewed from the incident side of the light;
 the angle (ϕ_{pol1}), which the absorption axis α of the first polarizing plate forms with respect to the normal direction X, is 42 degrees counterclockwise when viewed from the incident side of the light; and
 the angle (ϕ_{pol2}), which the absorption axis ϵ of the second polarizing plate forms with respect to the normal direction X, is set at 13 degrees counterclockwise when viewed from the incident side of the light.

6. The liquid crystal display device according to any of Claims 1 to 5, wherein the N_z coefficient represented by the following Formula (1) of the first phase difference plate is set within the range of -0.5 to 2.0, and the N_z coefficient represented by the following Formula (1) of the second phase difference plate is set within the range of -0.5 to 2.0.

$$N_z = (n_x - n_z)/(n_x - n_y) \quad \text{Formula (1)}$$

(In the formula, n_x denotes a refractive index in the X axis direction of the phase difference plate, n_y denotes a refractive index in the Y axis direction of the phase difference plate, and n_z denotes a refractive index in the Z

axis direction of the phase difference plate.)

- 5 7. The liquid crystal display device according to any of Claims 1 to 6, wherein the N_z coefficient represented by the
aforementioned Formula (1) of the first phase difference plate is set at 0.5, and the N_z coefficient represented by
the aforementioned Formula (1) of the second phase difference plate is set at 0.3.
8. The liquid crystal display device according to any of Claims 1 to 7, wherein the plurality of concave surfaces of the
metal reflection film are formed continuously, and each concave surface is made of a part of a sphere.
- 10 9. The liquid crystal display device according to Claim 8, wherein the depths of the plurality of concave portions are
within the range of 0.1 μm to 3 μm , the distribution of the angles of inclination of the concave portion inner surfaces
is within the range of -30 degrees to +30 degrees, and the pitches between adjacent concave portions are within
the range of 5 μm to 50 μm .
- 15 10. The liquid crystal display device according to any of Claims 1 to 9, wherein:
- the plurality of concave portions include the following first longitudinal section and second longitudinal section,
each passing the deepest point of the concave portion;
- 20 the shape of the inner surface of the first longitudinal section comprises a first curve from one periphery portion
of the concave portion to the deepest point and a second curve from the deepest point to other periphery
portion of the concave portion in succession to this first curve, and the average value of the absolute values
of the angles of inclination of the first curve with respect to the base material surface is specified to be larger
than the average value of the absolute values of the angles of inclination of the second curve with respect to
the base material surface;
- 25 while the second longitudinal section is orthogonal to the first longitudinal section, and the shape of the inner
surface thereof comprises a shallow type curve and deep type curves existing on both sides of the shallow
type curve and having curvature radii smaller than that of the shallow type curve.
- 30 11. The liquid crystal display device according to Claim 10, wherein the plurality of concave portions are formed in
order that each of the first longitudinal sections and the second longitudinal sections is in the same direction and
each of the first curves is orientated unidirectionally, and the reflector is placed in order that the first curves in
respective concave portions locate above the second curves when viewed from an observer.
- 35 12. The liquid crystal display device according to Claim 10 or 11, wherein the angles of inclination of the first curve
and the second curve are zero with respect to the base material surface at the position where they are in contact
with each other.
- 40 13. The liquid crystal display device according to any of Claims 10 to 12, wherein the depths of the plurality of concave
portions are within the range of 0.1 μm to 3 μm and are formed on a random basis.
- 45 14. The liquid crystal display device according to any of Claims 10 to 13, wherein the plurality of concave portions are
placed adjacently to each other on a random basis.
- 50 15. The liquid crystal display device according to any of Claims 10 to 15, wherein the reflectance reaches a peak at
the angle of the specular reflection with respect to the metal reflection film surface, the integral of the reflectance
within the range of the reflection angle smaller than the angle of the specular reflection and the integral of the
reflectance within the range of the reflection angle larger than the angle of the specular reflection are different,
and the range of the reflection angle, in which the integral of the reflectance becomes large, of the reflector is set
above the angle of the specular reflection with respect to the metal reflection film surface when viewed from the
observer.
- 55 16. The liquid crystal display device according to any of Claims 1 to 15, wherein a color filter is placed between the
one transparent substrate constituting the liquid crystal cell and the transparent electrode placed on the inner
surface side thereof.

FIG. 1

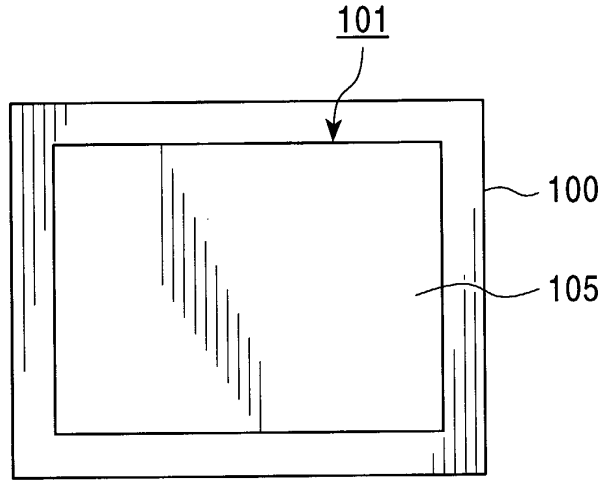

FIG. 2

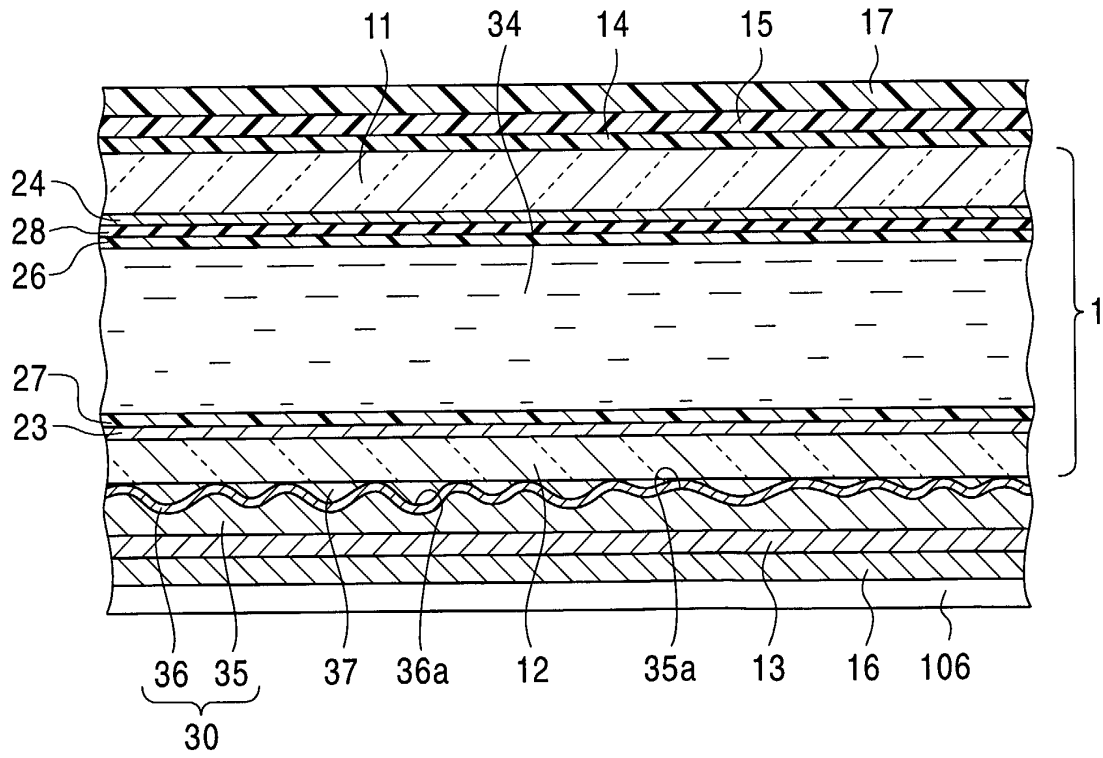

FIG. 3

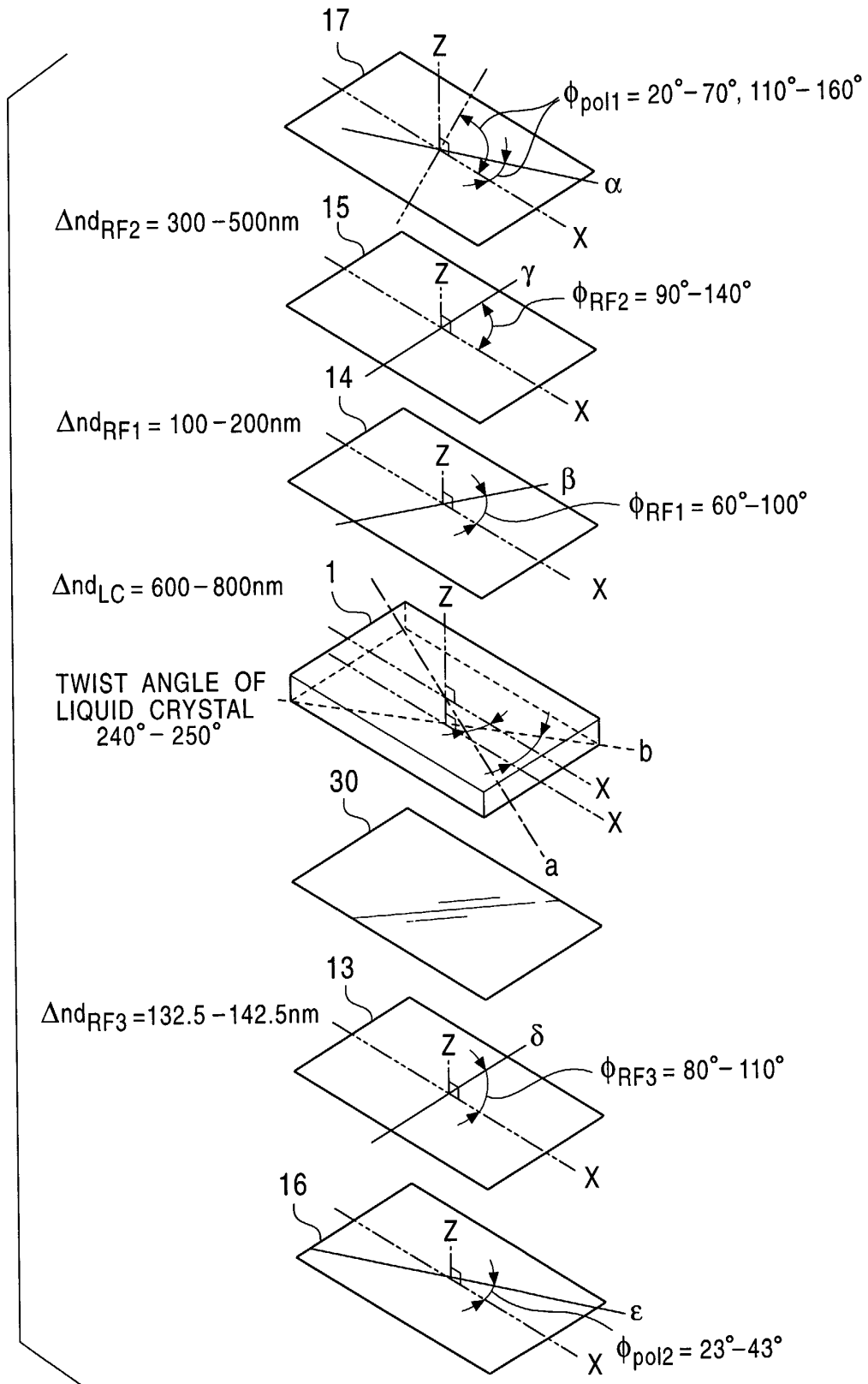

FIG. 4

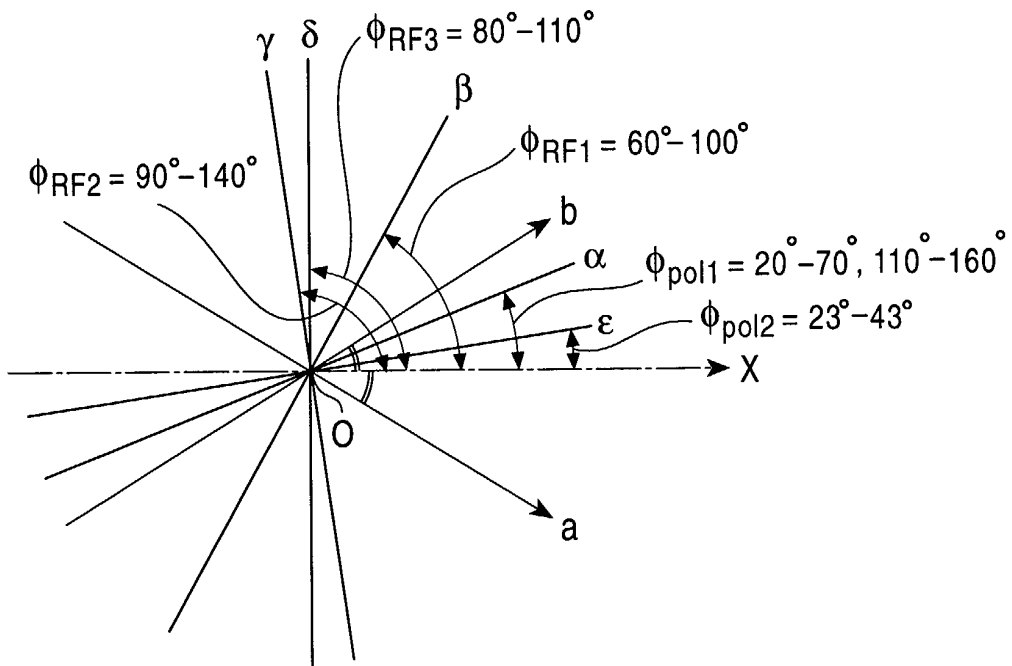

FIG. 5

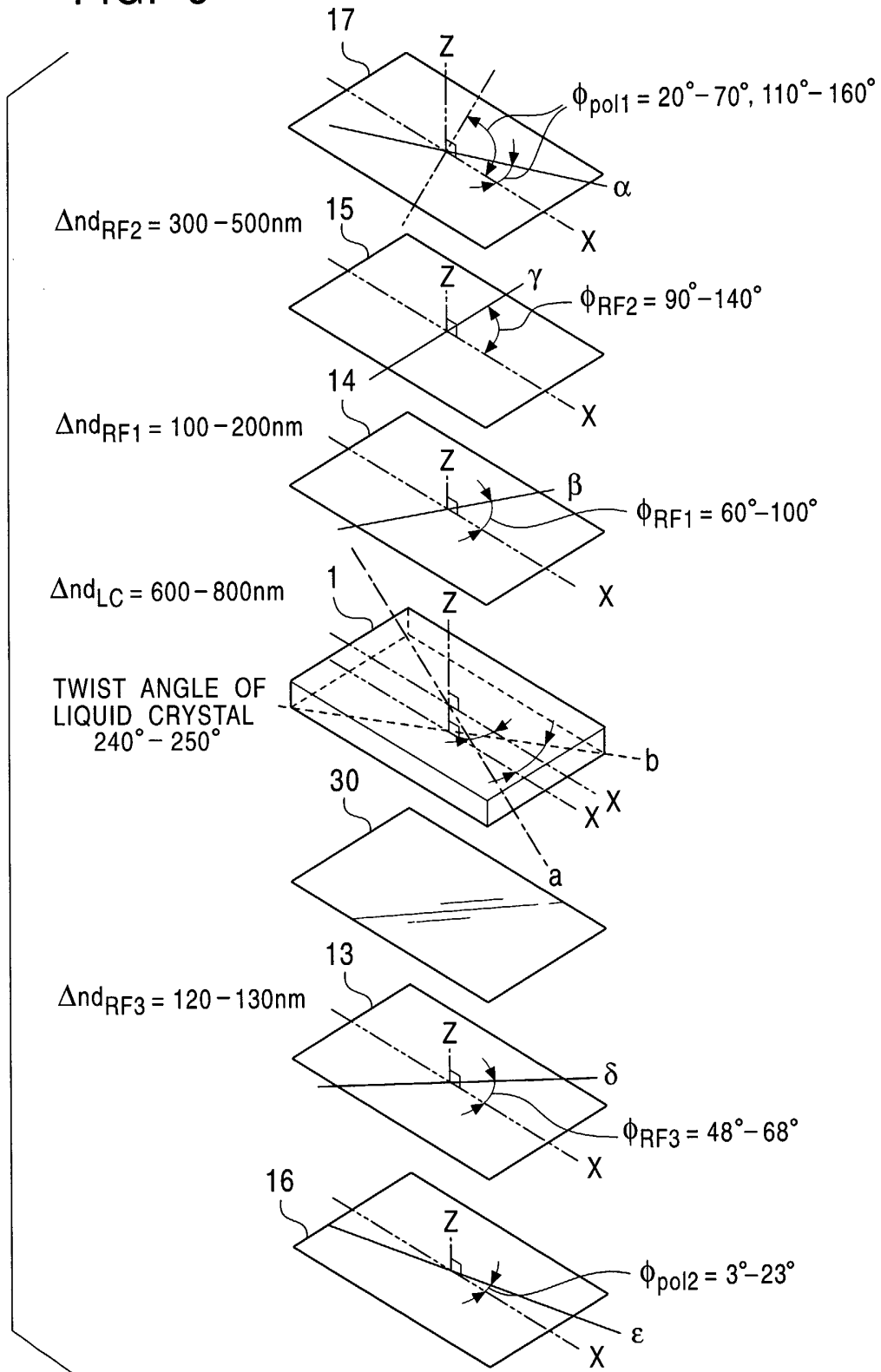

FIG. 6

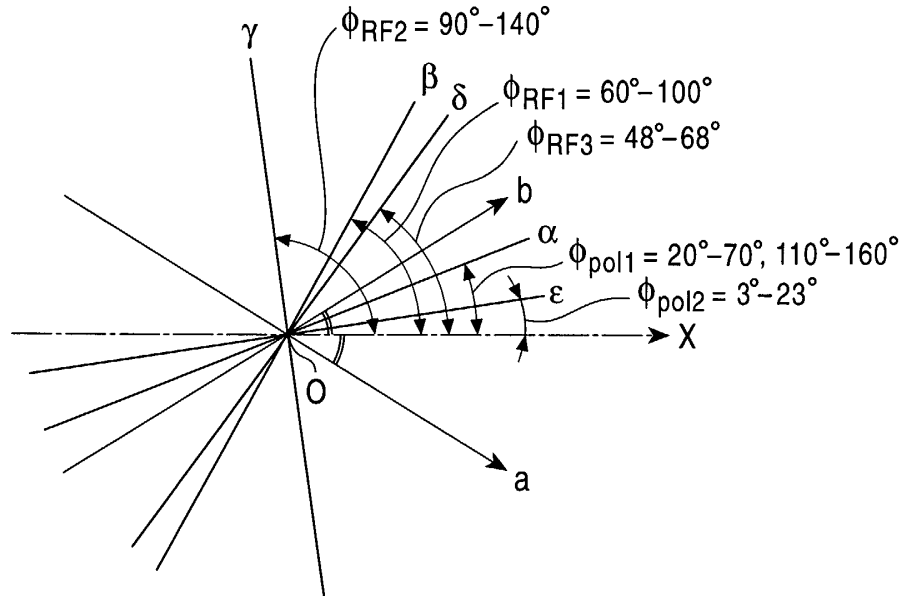

FIG. 7

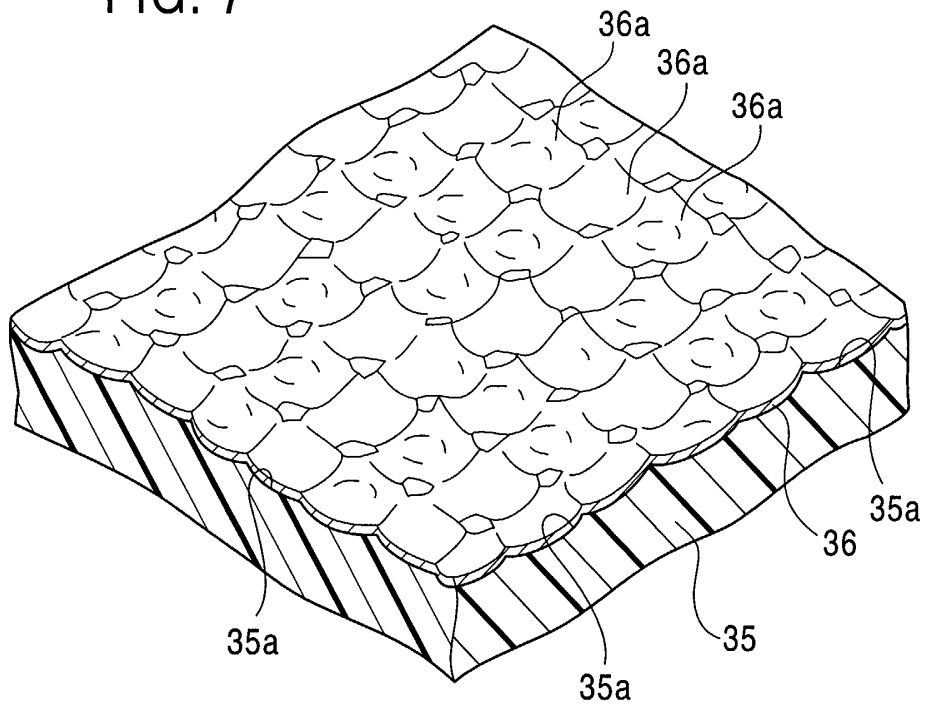

FIG. 8

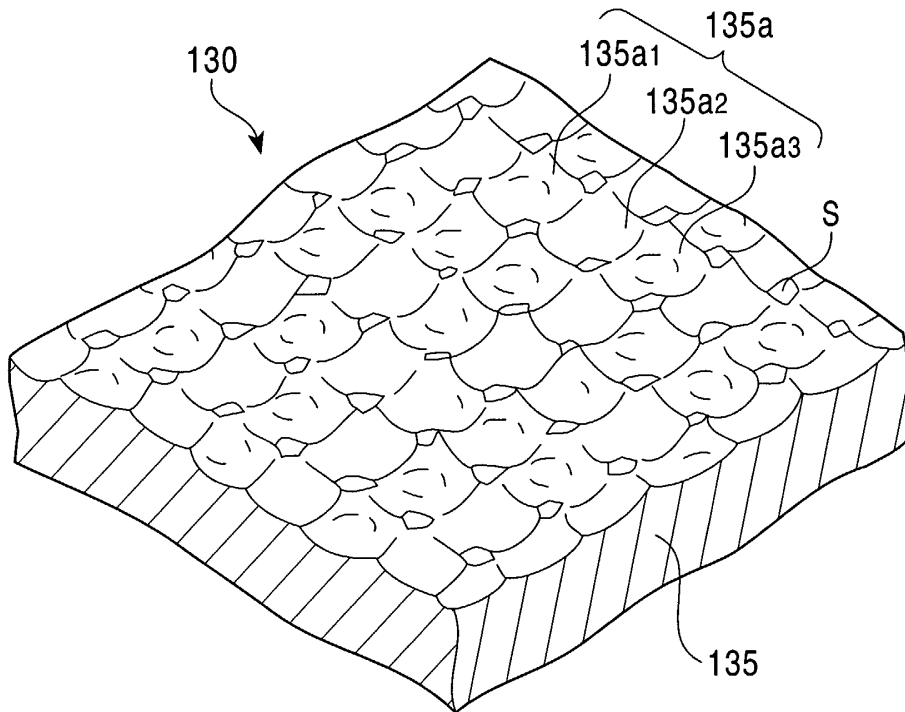

FIG. 9

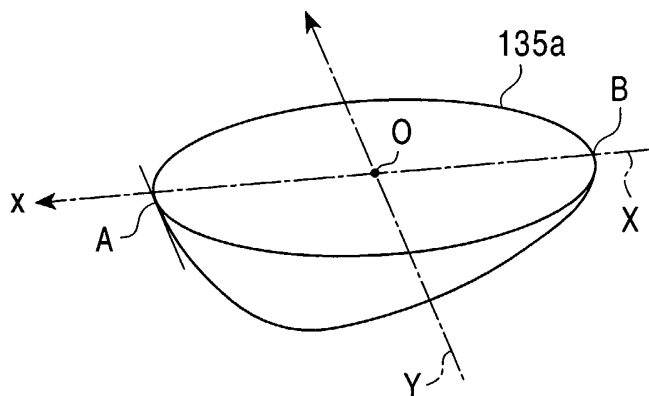

FIG. 10

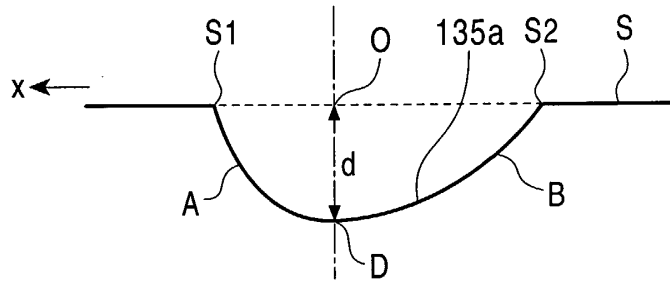

FIG. 11

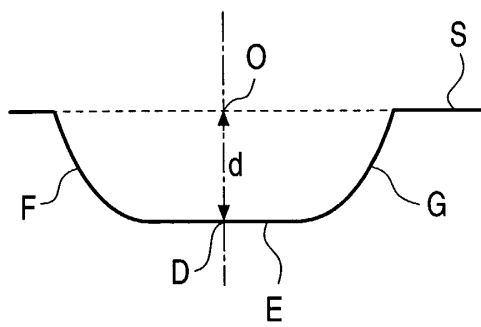

FIG. 12

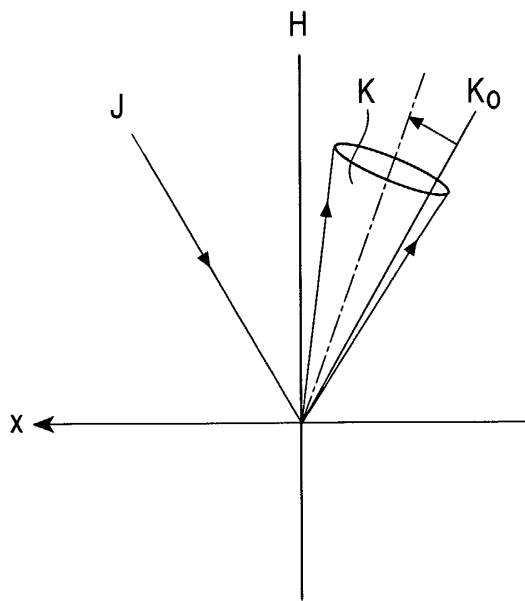

FIG. 13

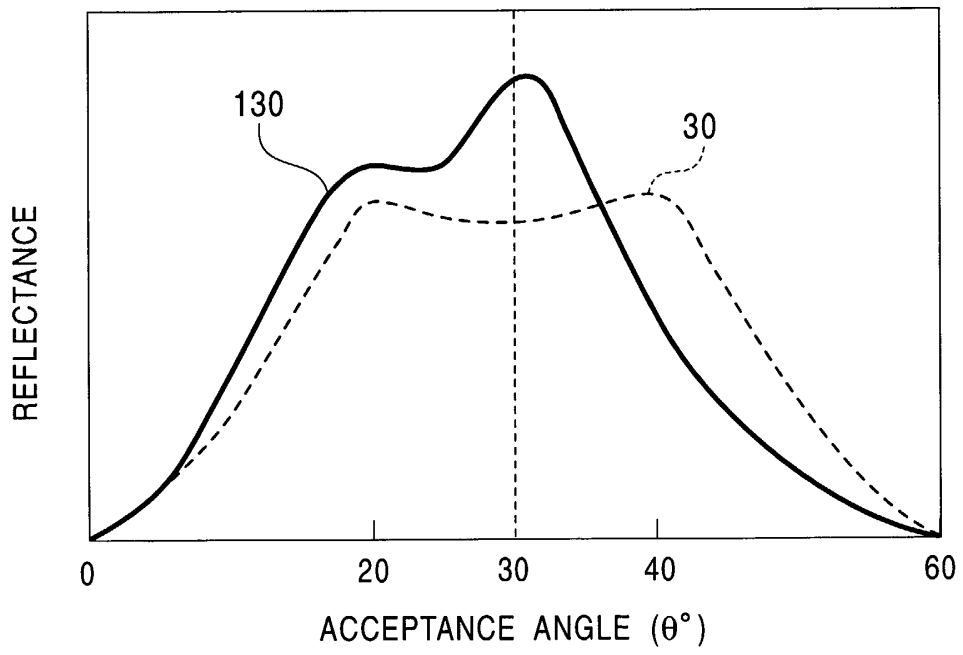

FIG. 14

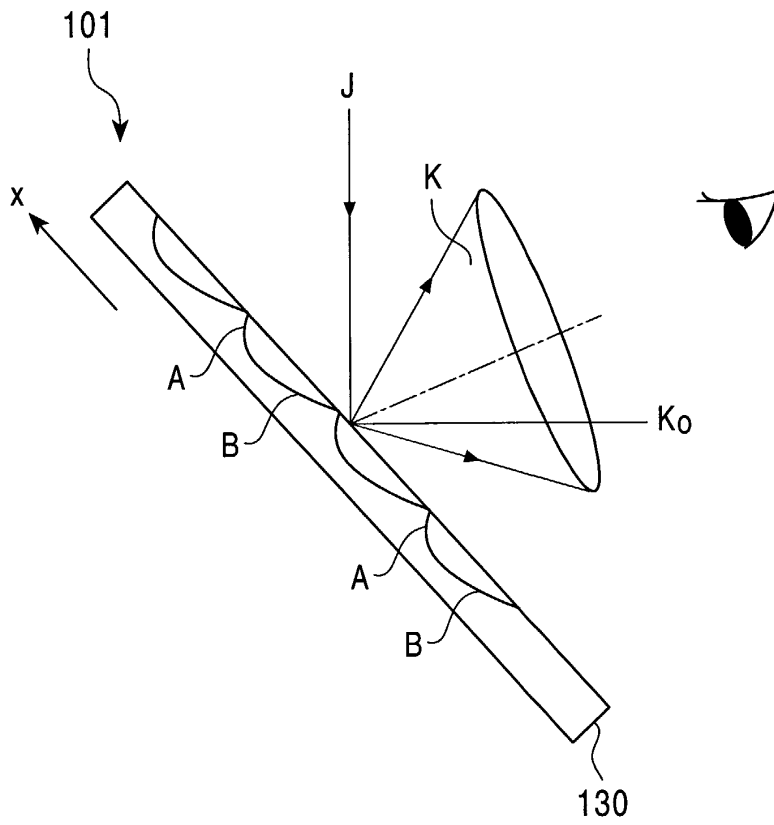

FIG. 15

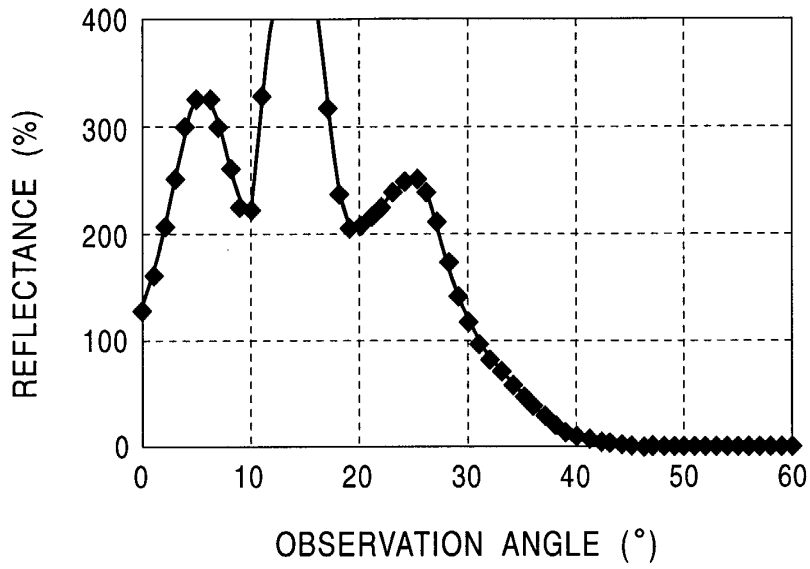

FIG. 16

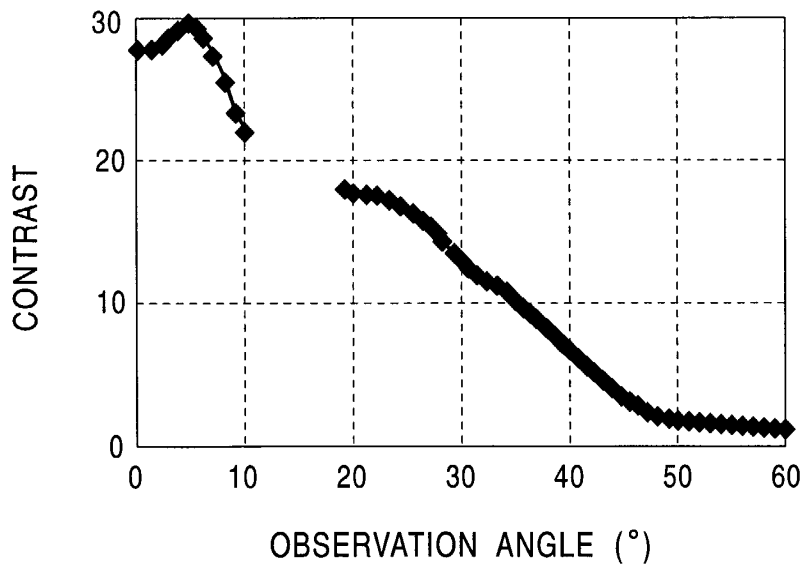

FIG. 17

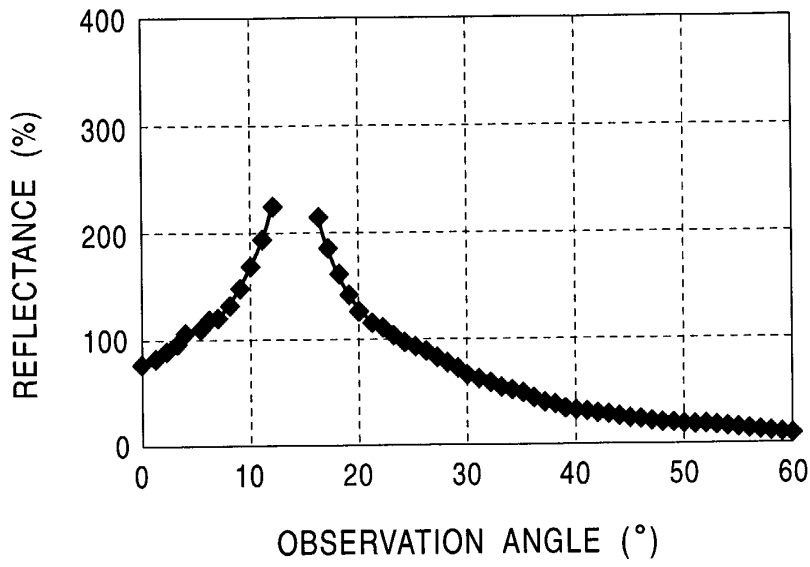

FIG. 18

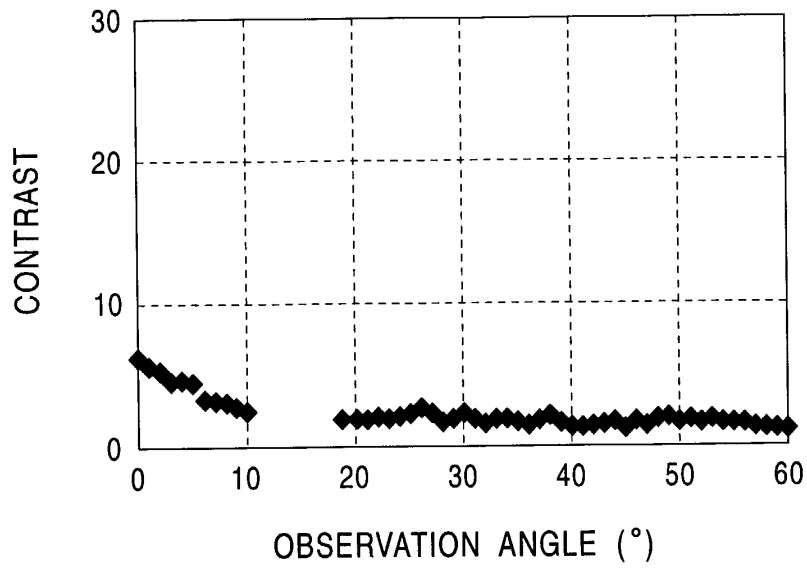

FIG. 19
PRIOR ART

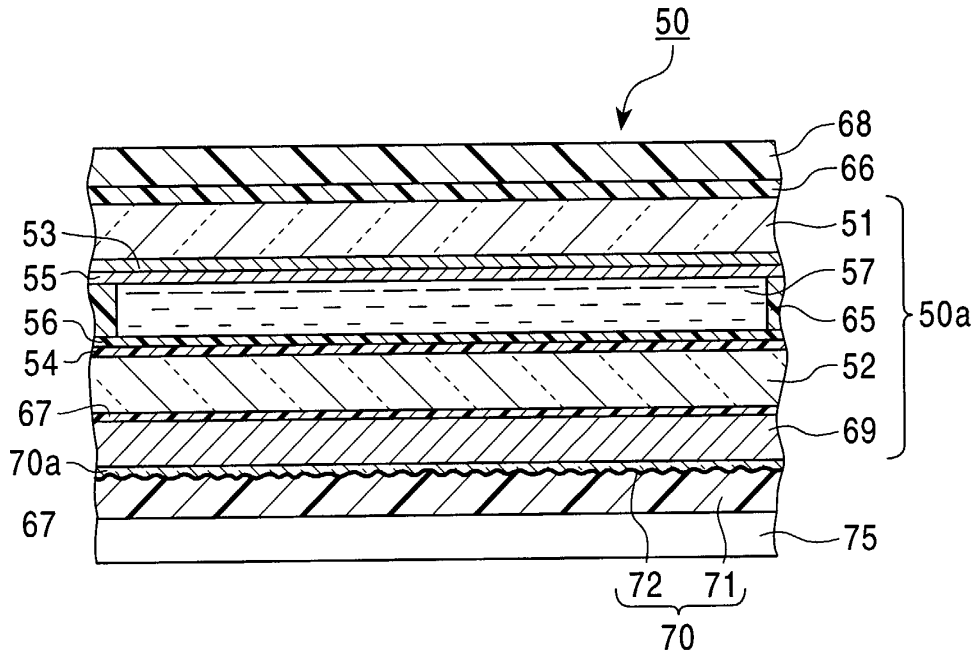
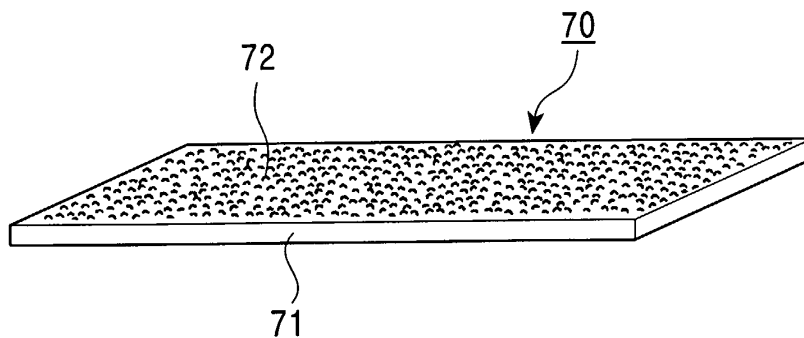

FIG. 20
PRIOR ART



专利名称(译)	半透明反射液晶显示装置		
公开(公告)号	EP1279994A2	公开(公告)日	2003-01-29
申请号	EP2002016025	申请日	2002-07-18
[标]申请(专利权)人(译)	阿尔卑斯电气株式会社		
申请(专利权)人(译)	ALPS ELECTRIC CO., LTD.		
当前申请(专利权)人(译)	ALPS ELECTRIC CO., LTD.		
[标]发明人	KANO MITSURU C O ALPS ELECTRIC CO LTD		
发明人	TANADA, TETSUSHI, C/O ALPS ELECTRIC CO., LTD. OHIZUMI, MITSUO, C/O ALPS ELECTRIC CO., LTD. KANO, MITSURU, C/O ALPS ELECTRIC CO., LTD.		
IPC分类号	G02F1/1335 G02F1/13363 G02F1/139		
CPC分类号	G02F1/133553 G02F1/13363		
优先权	2001228658 2001-07-27 JP		
其他公开文献	EP1279994A3		
外部链接	Espacenet		

摘要(译)

一种液晶显示装置，其特征在于，具有液晶单元，该液晶单元具有隔着液晶层相对的一对透明基板，第一和第二相位差板，和依次形成在透明基板的外表面侧上的第一偏振板，附着在透明基板的外表面侧上的反射器（30），以及第三相位差板（13）和第二偏振板（16）包括顺序地形成在所述透明基板的外表面侧上，但是在比所述反射器更远离所述外表面的一侧上，其中所述反射器通过在其上形成有凹部的基材上形成金属反射膜而构成，金属反射膜包括与所述凹部对应的多个凹面，所述金属反射膜以面向所述透明基板侧的方式安装在所述液晶单元上，所述金属反射膜的膜厚在5到50nm。

FIG. 2

