



(11) **EP 2 555 044 A1**

(12) **EUROPEAN PATENT APPLICATION**

(43) Date of publication:  
**06.02.2013 Bulletin 2013/06**

(51) Int Cl.:  
**G02F 1/1335 (2006.01)**

(21) Application number: **12162562.8**

(22) Date of filing: **30.03.2012**

(84) Designated Contracting States:  
**AL AT BE BG CH CY CZ DE DK EE ES FI FR GB GR HR HU IE IS IT LI LT LU LV MC MK MT NL NO PL PT RO RS SE SI SK SM TR**  
 Designated Extension States:  
**BA ME**

(72) Inventors:  
 • **Chung, Seong-eun**  
**Seoul (KR)**  
 • **Jung, Il-yong**  
**Gyeonggi-do (KR)**

(30) Priority: **03.08.2011 KR 20110077477**

(74) Representative: **Bruce, Alexander Richard Henry et al**  
**Venner Shipley LLP**  
**200 Aldersgate**  
**London EC1A 4HD (GB)**

(71) Applicant: **Samsung Electronics Co., Ltd.**  
**Suwon-si, Gyeonggi-do, 443-742 (KR)**

(54) **Display panel and display apparatus comprising the same**

(57) A display panel and a display apparatus including the same which employs a wire grid polarizing plate are provided. The display panel includes: first and second substrates; a liquid crystal layer which is interposed between the first and second substrates; first and second electrodes, which are interposed respectively between the first substrate and the liquid crystal layer and between

the liquid crystal layer and the second substrate, and which apply power to the liquid crystal layer; first and second wire grid polarizing plates which are formed on a surface of each of the first and second substrates and allow polarized light to be transmitted therethrough; and a phase difference compensation film which is interposed between the first and second wire grid polarizing plates and compensates for a phase difference of incident light.

FIG. 1

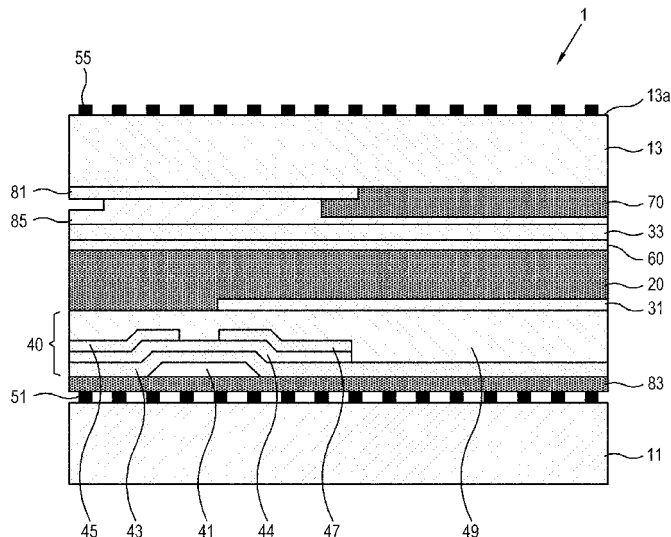

EP 2 555 044 A1

## Description

**[0001]** The present invention relates to a display panel including a liquid crystal layer and a display apparatus comprising the same, and more particularly, to a display panel and a display apparatus comprising the same which employs a wire grid polarizing plate.

**[0002]** Generally, a liquid crystal panel which is employed in a liquid crystal display apparatus as a flat panel display apparatus does not emit light itself, and thus, generally includes a backlight unit that is provided in a rear surface of the liquid crystal panel and emits surface light.

**[0003]** Light emitted by a light source of the backlight unit passes through optical elements such as a light guide plate, a diffusion plate and a prism sheet forming the backlight unit, and thus the light is incident to the liquid crystal panel with considerable part of the light lost.

**[0004]** The liquid crystal panel is driven and controlled pixel by pixel, and each pixel selectively receives incident light to realize an image. To accomplish the foregoing, the liquid crystal panel includes first and second substrates, a liquid crystal layer interposed between the first and second substrates and a polarizing plate which allows predetermined polarization of light out of the incident light to be selectively transmitted therethrough. The polarizing plate allows a predetermined polarized light to be transmitted therethrough and absorbs the remaining polarized light, to thereby absorb approximately 50% of incident light.

**[0005]** A display apparatus which includes the foregoing backlight unit and the liquid crystal panel suffers from a deterioration of brightness, as light from the light source is lost greatly after passing through the optical elements of the backlight unit and the liquid crystal panel.

**[0006]** To compensate for the light lost by the polarizing plate, a related art liquid crystal panel employs a dual brightness enhancement film (DBEF) including a multi-layer polymer thin film instead of an absorbent polarizing plate. In this case, part of the light reflected by the DBEF may be reused to compensate for the light loss to some extent. However, the DBEF with the multi-layer polymer incurs high manufacturing costs and requires complicated manufacturing processes.

**[0007]** Exemplary embodiments address at least the above problems and/or disadvantages and other disadvantages not described above. However, an exemplary embodiment is not required to overcome the disadvantages described above, and an exemplary embodiment may not overcome any of the problems described above.

**[0008]** Accordingly, one or more exemplary embodiments provide a display panel and a display apparatus having the same which may minimize light loss, reduce manufacturing costs and provide a simplified manufacturing process and an improved viewing angle.

**[0009]** According to an aspect of an exemplary embodiment, there is provided a display panel including: a first substrate; a second substrate; a liquid crystal layer which is interposed between the first and second substrates;

first and second electrodes which are configured to apply power to the liquid crystal layer, wherein the first electrode is interposed between the first substrate and the liquid crystal layer and the second electrode is interposed between the liquid crystal layer and the second substrate; first and second wire grid polarizing plates which are configured allow a polarized light to be transmitted there-through, wherein the first wire grid polarizing plate is disposed formed on a surface of the first substrate and the second wire grid polarizing plate is disposed on a surface of the second substrate; and a phase difference compensation film which is interposed between the first and second wire grid polarizing plates and is configured to compensate for a phase difference of incident light.

**[0010]** The first wire grid polarizing plate may be provided on a surface of the first substrate facing the liquid crystal layer.

**[0011]** The display panel may further include a first insulating layer which is interposed between the first wire grid polarizing plate and the first electrode and which electrically insulates the first wire grid polarizing plate and the first electrode.

**[0012]** The second wire grid polarizing plate may be provided on a surface of the second substrate opposite to the liquid crystal layer.

**[0013]** The second wire grid polarizing plate may be provided on a surface of the second substrate facing the liquid crystal layer, and further comprises a second insulating layer, which is interposed between the second wire grid polarizing plate and the second electrode and which electrically insulates the second wire grid polarizing plate and the second electrode.

**[0014]** The phase difference compensation film may be interposed at least one of between the first wire grid polarizing plate and the liquid crystal layer and between the liquid crystal layer and the second wire grid polarizing plate.

**[0015]** The phase difference compensation film may be interposed between the liquid crystal layer and the second electrode.

**[0016]** The phase difference compensation film may be interposed between the between the second electrode and the second wire grid polarizing plate.

**[0017]** The phase difference compensation film may have a same, but negative value with respect to a retardation value of the liquid crystal layer.

**[0018]** The phase difference compensation film may include a triacetyl cellulose film of a predetermined thickness.

**[0019]** The display panel may further include a color filter which is interposed between the first substrate and the liquid crystal layer, and allows a predetermined amount of light out of an incident light to be transmitted therethrough and realizes a color image.

**[0020]** The display panel may further include a color filter which is interposed between the liquid crystal layer and the second substrate and allows a predetermined amount of light out of an incident light to be transmitted

therethrough and realizes a color image.

**[0021]** According to an aspect of another exemplary embodiment, there is provided a display apparatus including: a display panel according to claim 1; and a backlight unit which emits light to the display panel.

**[0022]** The display apparatus may further include a first insulating layer which is interposed between the first wire grid polarizing plate and the first electrode to electrically insulate the first wire grid polarizing plate and the first electrode.

**[0023]** The display apparatus may further include a color filter which is interposed between the first substrate and the liquid crystal layer, and allows a predetermined quantity of light out of an incident light to be transmitted therethrough and realizes a color image.

**[0024]** The display apparatus may further include a color filter which is interposed between the liquid crystal layer and the second substrate, and allows a predetermined quantity of light out of an incident light to be transmitted therethrough and realizes a color image.

**[0025]** The above and/or other aspects will become apparent and more readily appreciated from the following description of the exemplary embodiments, taken in conjunction with the accompanying drawings, in which:

FIG. 1 is a sectional view of a display panel according to a first exemplary embodiment;

FIG. 2 is a perspective view of a first wire grid polarizing plate of the display panel according to the first exemplary embodiment;

FIG. 3 is a sectional view of a display panel according to a second exemplary embodiment;

FIG. 4 is a sectional view of a display panel according to a third exemplary embodiment;

FIG. 5 is a sectional view of a display panel according to a fourth exemplary embodiment;

FIG. 6 is a sectional view of a display panel according to a fifth exemplary embodiment; and

FIG. 7 is an exploded perspective view of a display apparatus according to an exemplary embodiment.

**[0026]** Below, exemplary embodiments will be described in detail with reference to accompanying drawings so as to be easily realized by a person having ordinary knowledge in the art. The exemplary embodiments may be embodied in various forms without being limited to the exemplary embodiments set forth herein. Descriptions of well-known parts are omitted for clarity, and like reference numerals refer to like elements throughout. Additionally, in the drawings, the thicknesses of layers, for example, may be exaggerated for clarity.

**[0027]** FIG. 1 is a sectional view of a display panel according to an exemplary embodiment. FIG. 2 is a perspective view of a first substrate and a first wire grid polarizing plate in FIG. 1.

**[0028]** Referring to the drawings, a display panel 1 according to the exemplary embodiment includes first and second substrates 11 and 13 which are disposed to face

each other; a liquid crystal layer 20 which is interposed between the first and second substrates 11 and 13; first and second electrodes 31 and 33; a pixel layer 40; first and second wire grid polarizing plates 51 and 55; and a phase difference compensation film 60. The display panel 1 according to the exemplary embodiment may further include a color filter 70 which realizes a color image.

**[0029]** The display panel 1 according to the present exemplary embodiment may be employed in an image device such as a television (TV) or a monitor, a mobile terminal or a display apparatus for exhibition and advertisement. etc. For example, the mobile terminal may include a mobile phone, a portable multimedia player (PMP), a netbook, a laptop and an electronic book terminal. etc.

**[0030]** The first and second substrates 11 and 13 include a transparent material through which light is transmitted from a backlight unit (not shown).

**[0031]** The liquid crystal layer 20 includes pixels which are individually controlled in arrangement by a voltage applied to the first and second electrodes 31 and 33 to realize an image. The liquid crystal layer 20 may include a liquid crystal mode such as a vertical alignment (VA) mode, a patterned vertical alignment (PVA) mode, a twisted nematic (TN) mode, and an in-plane switching (IPS) mode. The liquid crystal layer 20 may divide or pattern sub-pixels or adjust a refractive index of liquid crystals uniformly to improve a viewing angle of light.

**[0032]** The pixel layer 40 includes a thin film transistor (TFT), and controls the first and second electrodes 31 and 33 to thereby control a liquid crystal arrangement of the liquid crystal layer 20 pixel by pixel. Each pixel may include a plurality of sub-pixels.

**[0033]** The sub-pixel according to the present exemplary embodiment means the smallest unit of pixel to which an image gray scale corresponding to red, green and blue colors is input. A plurality of sub-pixels which represents a single image signal is defined a pixel.

**[0034]** The pixel layer 40 includes a gate electrode 41, a gate insulating layer 43, a drain electrode 45, a source electrode 47 and a passivation film 49 which form the TFT.

**[0035]** The gate electrode 41 may include a metal single or multi layers. A gate wire (not shown) and a gate pad (not shown) are formed on the same layer as the gate electrode 41. The gate wire is connected to the gate electrode 41 and is arranged in a transverse direction of the display panel 1. The gate pad is connected to a gate driver (not shown) and transmits a driving signal to the gate wire. A maintenance electrode (not shown) may be further formed on the same layer as the gate electrode 41 to accumulate electric charge. The gate insulating layer 43 includes silicon nitride (SiN<sub>x</sub>) and covers the gate electrode 41 and the maintenance electrode.

**[0036]** A semiconductor layer 44 includes a semiconductor such as amorphous silicon and is formed on the gate insulating layer 43. An ohmic contact layer (not shown) which includes n+ hydrogenated amorphous sil-

icon highly doped with silicide or an n-type dopant may be formed on the semiconductor layer 44. In this case, the ohmic contact layer is removed from a channel between the drain electrode 45 and the source electrode 47. A data wire (not shown) which includes a metal single or multi-layer is formed on the gate insulating layer 43. The source electrode 47 is separated from the drain electrode 45.

**[0037]** A passivation film 49 is formed on the drain electrode 45, the source electrode 47 and the semiconductor layer 44 which is not covered by the drain electrode 45 and the source electrode 47.

**[0038]** The first electrode 41 is a pixel electrode formed between the first substrate 11 and the liquid crystal layer 20, i.e., on the passivation film 49. The first electrode 41 includes a transparent conductive material such as indium tin oxide (ITO) or indium zinc oxide (IZO). The first electrode 41 is electrically connected to the source electrode 47.

**[0039]** A black matrix 81 and a second electrode 33 are formed on the second substrate 13. The black matrix 81 divides sub-pixels, and prevents external light from being introduced to the TFT. The black matrix 81 may typically include a photosensitive organic material added with a black pigment such as carbon black or titanium oxide.

**[0040]** The second electrode 33 is interposed between the second substrate 13 and the liquid crystal layer 20, and includes a common electrode forming a voltage corresponding to the first electrode 31. Like the first electrode 31, the second electrode 33 includes a transparent conductive material such as ITO or IZO. The second electrode 33 directly applies a voltage to the liquid crystal layer 20 together with the first electrode 31.

**[0041]** An overcoating layer 85 is formed on the second electrode 33. The overcoating layer 85 makes the black matrix 81 and the color filter 70 flat and protects the black matrix 81. The overcoating layer 85 may include acrylic epoxy.

**[0042]** The first wire grid polarizing plate 51 is formed in, on or adjacent a surface of the first substrate 11, and allows predetermined polarized light to be transmitted therethrough and reflects other polarized light again. As shown in FIG. 2, the first wire grid polarizing plate 51 is shaped like a bar which is arranged in a certain direction on the first substrate 11. It should be noted that when an item is referred to as being "on" a layer or a substrate, it can be disposed on the layer or substrate, or embedded within the layer or substrate. Additionally, other intervening layers may be present, for example, between the first wire grid polarizing plate and the first substrate. The term "adjacent to a surface" may be used to refer to a plate on a surface of the substrate, in the substrate or separated from the substrate by one or more intervening layers.

**[0043]** The first wire grid polarizing plate 51 includes a metal layer 53 and a hard mask 54. The manufacturing process of the first wire grid polarizing plate 51 includes

a process of depositing the metal layer 53 on the first substrate 11, a process of forming the hard mask 54 in a predetermined pattern on the metal layer 53, and a process of patterning the metal layer 53 by nano imprint lithography (NIL).

**[0044]** The metal layer 53 may include metal such as aluminum (Al), silver (Ag) or copper (Cu) or a high strength alloy such as molybdenum-tungsten (MoW). The metal layer 53 may include conductive polymer. The metal or polymer layer may generally be termed a conductive layer. The hard mask 54 protects the metal layer 53 and improves polarizing performance of the metal layer 53. The hard mask 54 may include a dielectric substance such as SiO<sub>2</sub>.

**[0045]** The first wire grid polarizing plate 51 is regularly arranged as a unit grid with predetermined height (H) and width (W). A cycle of the unit grid forming the first wire grid polarizing plate 51, i.e., a pitch is varied by color of light to be emitted. That is, if the pitch of the unit grid is adjusted into 1/2 or less of a wavelength of incident light, a diffracted wave is not formed, and only transmissive light and reflective light exist. The first wire grid polarizing plate 51 allows light having a certain polarizing component to be transmitted therethrough, and includes a pitch to allow light in all wavelengths to be transmitted therethrough. In particular, the pitch may be smaller than 1/2 of a wavelength of blue light. The first wire grid polarizing plate 51 according to the present exemplary embodiment is 150 nm in height and 100 to 150 nm in pitch. The ratio of height to width of the first wire grid polarizing plate 51 may be approximately 1:3 or more.

**[0046]** If the first wire grid polarizing plate 51 has the foregoing configuration, S polarized light in parallel with the grid is reflected and P polarized light vertical to the grid out of light received by the first wire grid polarizing plate 51 is transmitted. That is, out of light as non-polarized light received by the backlight unit, the P polarized light is transmitted through the first wire grid polarizing plate 51 to the liquid crystal layer 20, whereas the S polarized light is reflected to the backlight unit and reused.

**[0047]** Referring to FIG. 1, the first wire grid polarizing plate 51 may be formed on a surface of the first substrate 11 facing the liquid crystal layer 20. Then, the display panel 1 may further include a first insulating layer 83 which is interposed between the first wire grid polarizing plate 51 and the pixel layer 40 to electrically insulate the first wire grid polarizing plate 51 and the pixel layer 40. The arrangement of the first wire grid polarizing plate 51 is not limited to that as shown in FIG. 1. Alternatively, the first wire grid polarizing plate 51 may be formed in another surface of the first substrate 11, i.e., on a surface not facing the liquid crystal layer 20.

**[0048]** The second wire grid polarizing plate 55 may be formed in, on or adjacent a surface of the second substrate 13, and allows predetermined polarized light to be transmitted therethrough to thereby realize an image according to an arrangement direction of liquid crystals controlled by sub-pixel of the liquid crystal layer 20.

The second wire grid polarizing plate 55 is manufactured in a substantially same method as that of the first wire grid polarizing plate 51, and a grid arrangement direction thereof is vertical or in the same direction as that of the first wire grid polarizing plate 51.

**[0049]** As shown in FIG. 1, the second wire grid polarizing plate 55 may be provided on a first surface 13a of the second substrate 13 which is disposed on a surface opposite to a surface facing the liquid crystal layer 20. In this case, light with polarizing direction that is individually selected pixel by pixel is transmitted from the liquid crystal layer 20 to the second substrate 13 and then selectively transmitted through the second wire grid polarizing plate 55 to thereby realize a predetermined image.

**[0050]** As shown in FIG. 3, in a display panel according to a second exemplary embodiment, a second wire grid polarizing plate 55 may be provided on a second surface 13b of the second substrate 13 facing the liquid crystal layer 20. In this case, the display panel may further include a second insulating layer 87 which electrically insulates the second wire grid polarizing plate 55.

**[0051]** The display panel including the liquid crystal layer 20 has the liquid crystal layer that is optically anisotropic. Therefore, if the linearly polarized light which is transmitted through the first wire grid polarizing plate 51 passes through liquid crystal cells of the liquid crystal layer 20 vertically or at a slant, a retardation value varies and causes a phase difference. Then, properties of transmissive light according to a viewing angle vary and a viewing angle becomes narrow.

**[0052]** The phase difference compensation film 60 may be employed to solve the problem of a narrowed viewing angle that may arise when the polarized light is converted by the wire grid polarizing plate in a liquid crystal mode such as VA mode or TN mode. That is, the phase difference compensation film 60 is a phase difference plate which has the same, but negative, value with respect to the retardation value of the liquid crystal, and compensates for the retardation value of the liquid crystal and improves the viewing angle.

**[0053]** The phase difference compensation film 60 may be provided in at least one area between the first and second wire grid polarizing plates 51 and 55. That is, the phase difference compensation film 60 may be interposed at least one of between the first wire grid polarizing plate 51 and the liquid crystal layer 20, and between the liquid crystal layer 20 and the second wire grid polarizing plate 55.

**[0054]** FIGS. 1 and 3 illustrate the phase difference compensation film 60 which is interposed between the liquid crystal layer 20 and the second electrode 33. FIG. 4 illustrates the phase difference compensation film 60 which is interposed between the second electrode 33 and the second substrate 13.

**[0055]** The phase difference compensation film 60 may include a triacetyl cellulose (TAC) film in a predetermined thickness. As shown in FIGS. 1, 3 and 4, the phase difference compensation film 60 may include one

sheet of V-TAC film in a thickness corresponding to a predetermined reference wavelength  $\lambda$  of incident light. As shown in FIG. 5, the phase difference compensation film 60 may include two sheets of N-TAC films 61 and 63 in a thickness of  $\lambda/2$ . The two sheets 61, 63 forming the phase difference compensation film may be separate from each other. In particular, the sheets forming the phase difference compensation film may be separated by one or more intervening layers, eg separated by the liquid crystal layer and/or the first electrode.

**[0056]** As the phase difference compensation film 60 compensates for the phase difference as described above, the narrowed viewing angle which arises from the display panel including the wire grid polarizing plate may be prevented.

**[0057]** The color filter 70 allows light in a predetermined wavelength to be selectively transmitted therethrough to thereby realize a color image. As shown in FIG. 1, the color filter 70 may be interposed between the liquid crystal layer 20 and the second substrate 13. If light is emitted from a lower part of the first substrate 11, light having a certain polarizing light component and being transmitted through the first wire grid polarizing plate 51 is transmitted through the liquid crystal layer 20 and the color filter 70 and is emitted by light in a predetermined color. As shown in FIG. 6, the color filter 70 may be provided in the pixel layer 40, in which case the light in a predetermined color determined through the transmission of the color filter 70 is transmitted through the liquid crystal layer 20 to thereby realize an image.

**[0058]** According to the present exemplary embodiment, the light is transmitted from the first substrate 11 to the liquid crystal layer 20, but not limited thereto. Alternatively, the light may be transmitted from the second substrate 13 to the liquid crystal layer 20. The display panel 1 according to the exemplary embodiment may further include a reflection restricting layer (not shown) which is arranged on an external surface of one of the first substrate 11 and the second substrate 13, i.e., an external surface of the substrate from which light is emitted substantially. The reflection restricting layer reduces reflection of external light from the surface of the display panel 1 and prevents damage to definition due to the external light. The reflection restricting layer may include an anti-reflection film or anti-glare film or a moth-eye pattern layer formed by a nano technology on an external surface of the substrate.

**[0059]** The display panel 1 may further include a panel driver 400 shown in FIG. 7.

**[0060]** FIG. 7 is a perspective view of the display apparatus according to the exemplary embodiment.

**[0061]** Referring to FIG. 7, the display apparatus 100 includes a display panel 1, a backlight unit 200 and a housing 300 which accommodates the foregoing elements, and an image provider (not shown).

**[0062]** The display panel 1 includes a first substrate 11, a second substrate 13 facing the first substrate 11, a liquid crystal layer (not shown) interposed between the

first and second substrates 11 and 13, and a panel driver 400 driving a pixel layer (not shown) to display an image signal. The display panel 1 receives light from the outside and controls the quantity of light transmitted through the liquid crystal layer interposed between the first and second substrates 11 and 13 to thereby display an image. The display panel 1 is substantially the same as the display panel according to the exemplary embodiment described by referring to FIGS. 1 to 6, and thus detailed description of elements other than the panel driver 400 will be omitted.

**[0063]** The panel driver 400 may include a gate driving integrated circuit (IC) 410, a data chip film package 420 and a printed circuit board (PCB) 430. The gate driving IC 410 may be formed on the first substrate 11 and connected to each gate line formed in the first substrate 11. The data chip film package 420 may be connected to each data line formed in the first substrate 420. The data chip film package 420 may include a wire pattern in which a semiconductor chip is formed in a base film, and a tape automated bonding (TAB) tape connected by TAB technology. For example, the data chip film package may include a tape carrier package (TCP) or a chip on film (COF).

**[0064]** Various parts may be mounted in the PCB 430 to input a gate driving signal to the gate driving IC 410 and input a data driving signal to the data chip film package 420.

**[0065]** The backlight unit 200 may be classified into a direct type and an edge type depending on an optical arrangement of a light source and application/non-application of a light guide plate. FIG. 7 illustrates the edge type backlight unit 200. In this case, the backlight unit 200 may include a light source 210, a light guide plate 220 to guide light emitted by the light source 210, a reflection sheet 230 provided below the light guide plate 220 and at least one optical sheet 240. The light source 210 is provided in at least one edge of the light guide plate 220. The light source 210 may include a light emitting diode (LED) array, a cold cathode fluorescent lamp (CCFL) or a hot cathode fluorescent lamp (HCFL). FIG. 7 illustrates first and second LED arrays 211 and 215 which are provided at opposite edges of the light guide plate 220. The first and second LED arrays 211 and 215 may be electrically connected to an inverter (not shown) to receive power therefrom.

**[0066]** The light guide plate 220 converts a progress path of light emitted by the light source 210, and guides light to be transmitted to the display panel 1 as plane light. The light guide plate 220 may include a panel including a transparent material such as acrylic or plastic. Various patterns may be formed in a rear surface of the light guide plate 220 to change the progress direction of the light incident to the light guide plate 220 to the display panel 1.

**[0067]** The reflection sheet 230 is installed in a lower surface of the light guide plate 220 and reflects light from a lower side to an upper side of the light guide plate 220.

More specifically, the reflection sheet 230 reflects light that has not been reflected by fine dot patterns formed in the rear surface of the light guide plate 220 back to an emission surface of the light guide plate 220 to thereby reduce loss of light incident to the display panel 1 and to improve uniformity of light transmitted to the emission surface of the light guide plate 220.

**[0068]** At least one optical sheet 240 is installed in the emission surface of the light guide plate 220 and diffuses and focuses light emitted by the light guide plate 220. The optical sheet 240 may include a diffusion sheet 241, a prism sheet 243 and a protection sheet (not shown). The diffusion sheet 241 may be interposed between the light guide plate 220 and the prism sheet 243 and scatter light transmitted by the light guide plate 220 and prevent light from being partially focused. The prism sheet 243 may have prisms in a predetermined shape in a certain arrangement to focus light diffused by the diffusion sheet 241 in a vertical direction of the display panel 1. The protection sheet may be formed on the prism sheet 243, protect a surface of the prism sheet 243 and diffuse light to distribute light uniformly. According to the present exemplary embodiment, the backlight unit includes an edge type, but is not limited thereto. Alternatively, the backlight unit may include a direct type of light source.

**[0069]** The housing 300 may include a bezel 301, a main body 303 and a rear cover 305. The rear cover 305 accommodates therein the backlight unit 200 and the display panel 1. The rear cover 305 may include a metal material to ensure strength to external shock and the connection to the ground.

**[0070]** The image provider is connected to the display panel 1 and provides the display panel 1 with an image signal.

**[0071]** As described above, a display panel and a display apparatus according to an exemplary embodiment employs a polarizing plate to thereby minimize light loss, reduce manufacturing costs and provide a simplified manufacturing process.

**[0072]** Further, the display panel and the display apparatus according to an exemplary embodiment has a phase difference compensation film interposed between first and second wire grid polarizing plates to compensate for a phase difference and to improve a viewing angle.

**[0073]** Although a few exemplary embodiments have been shown and described, it will be appreciated by those skilled in the art that changes may be made in these exemplary embodiments without departing from the principles of the present inventive concept, the range of which is defined in the appended claims.

## Claims

1. A display panel comprising:
  - a first substrate;
  - a second substrate;

- a liquid crystal layer which is interposed between the first and second substrates;  
 first and second electrodes which are configured to apply a voltage to the liquid crystal layer, wherein the first electrode is interposed between the first substrate and the liquid crystal layer and the second electrode is interposed between the liquid crystal layer and the second substrate;  
 first and second wire grid polarizing plates which are configured allow a polarized light to be transmitted therethrough, wherein the first wire grid polarizing plate is disposed adjacent to a surface of the first substrate and the second wire grid polarizing plate is disposed adjacent to a surface of the second substrate; and  
 a phase difference compensation film which is interposed between the first and second wire grid polarizing plates and is configured to compensate for a phase difference of incident light.
2. The display panel according to claim 1, wherein the first wire grid polarizing plate is disposed on a surface of the first substrate facing the liquid crystal layer.
  3. The display panel according to claim 2, further comprising a first insulating layer which is interposed between the first wire grid polarizing plate and the first electrode and which electrically insulates the first wire grid polarizing plate and the first electrode.
  4. The display panel as claimed in any one of claims 1 to 3, wherein the second wire grid polarizing plate is disposed on a surface of the second substrate opposite to the liquid crystal layer.
  5. The display panel as claimed in any one of claims 1 to 3, wherein the second wire grid polarizing plate is provided on a surface of the second substrate facing the liquid crystal layer, and further comprises a second insulating layer, which is interposed between the second wire grid polarizing plate and the second electrode and which electrically insulates the second wire grid polarizing plate and the second electrode.
  6. The display panel as claimed in any one of claims 1 to 5, wherein the phase difference compensation film is interposed at least one of between the first wire grid polarizing plate and the liquid crystal layer, and, between the liquid crystal layer and the second wire grid polarizing plate.
  7. The display panel according to claim 6, wherein the phase difference compensation film is interposed between the liquid crystal layer and the second electrode.
  8. The display panel according to claim 6, wherein the phase difference compensation film is interposed between the between the second electrode and the second wire grid polarizing plate.
  9. The display panel as claimed in any one of claims 1 to 8, wherein the phase difference compensation film has a same, but negative value with respect to a retardation value of the liquid crystal layer.
  10. The display panel as claimed in any one of claims 1 to 9, wherein the phase difference compensation film comprises a triacetyl cellulose film of a predetermined thickness.
  11. The display panel as claimed in any one of claims 1 to 10 wherein the phase difference compensation film comprises two separated sheets.
  12. The display panel as claimed in any one of claims 1 to 11, further comprising a color filter which is interposed between the first substrate and the liquid crystal layer, and is configured to allow a predetermined amount of light out of an incident light to be transmitted therethrough and realize a color image.
  13. The display panel as claimed in any one of claims 1 to 11, further comprising a color filter which is interposed between the liquid crystal layer and the second substrate and is configured to allow a predetermined amount of light out of an incident light to be transmitted therethrough and realize a color image.
  14. The display panel as claimed in any one of claims 1 to 12 wherein the first and/or second wire grid polarizing plate comprises a conductive layer and a hard mask.
  15. A display apparatus comprising:
    - a display panel as claimed in any one of claims 1 to 14; and
    - a backlight unit which emits light to the display panel.

FIG. 1

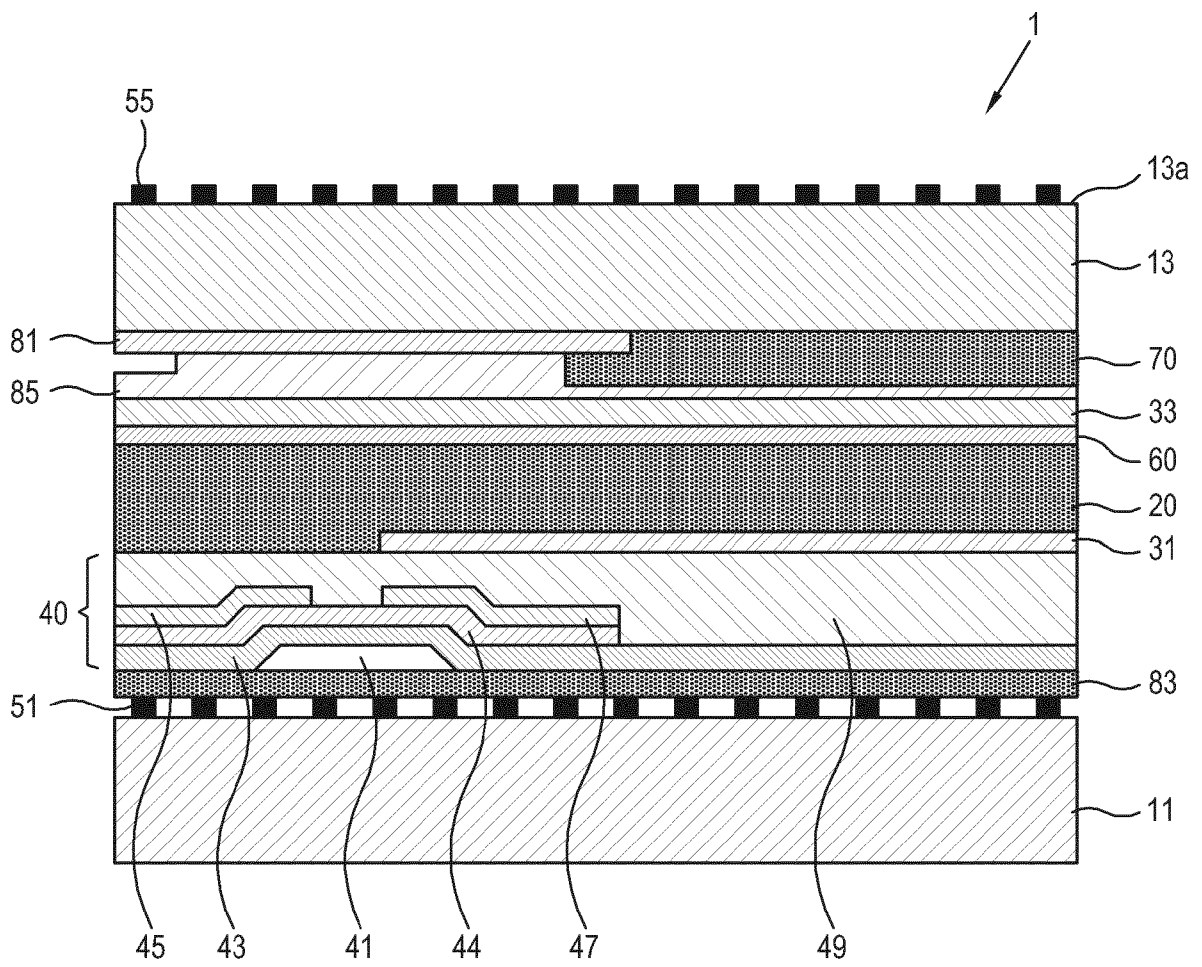

FIG. 2

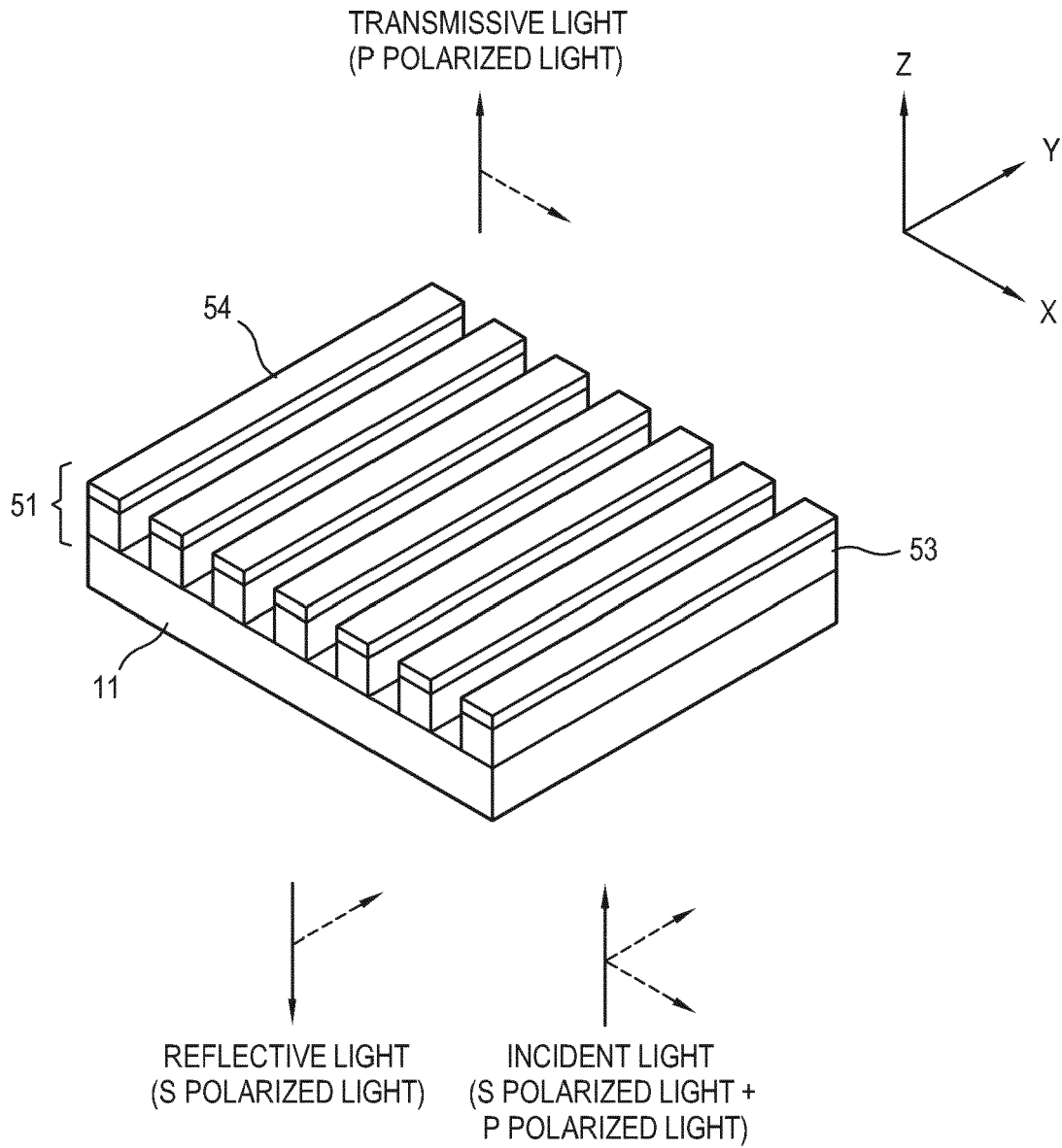

FIG. 3

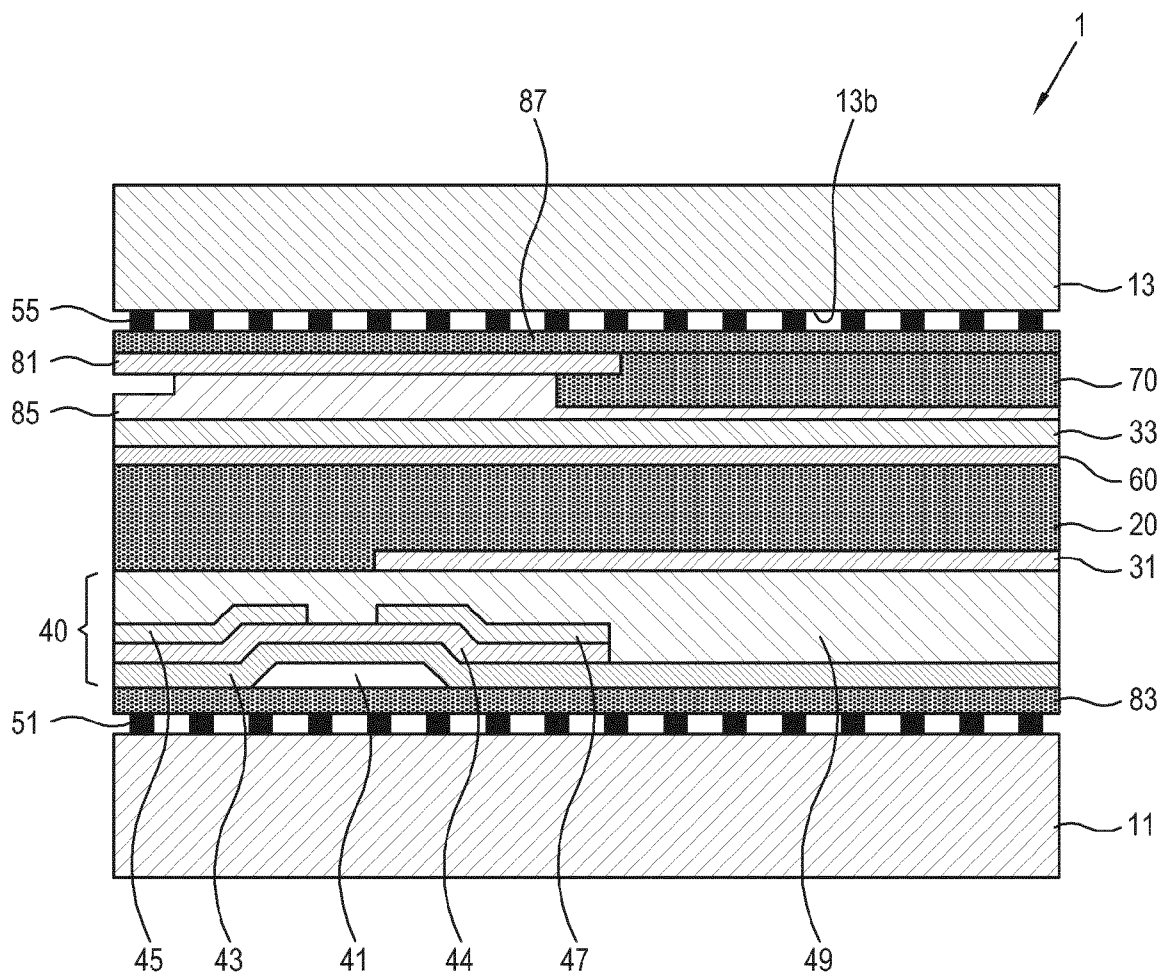

FIG. 4

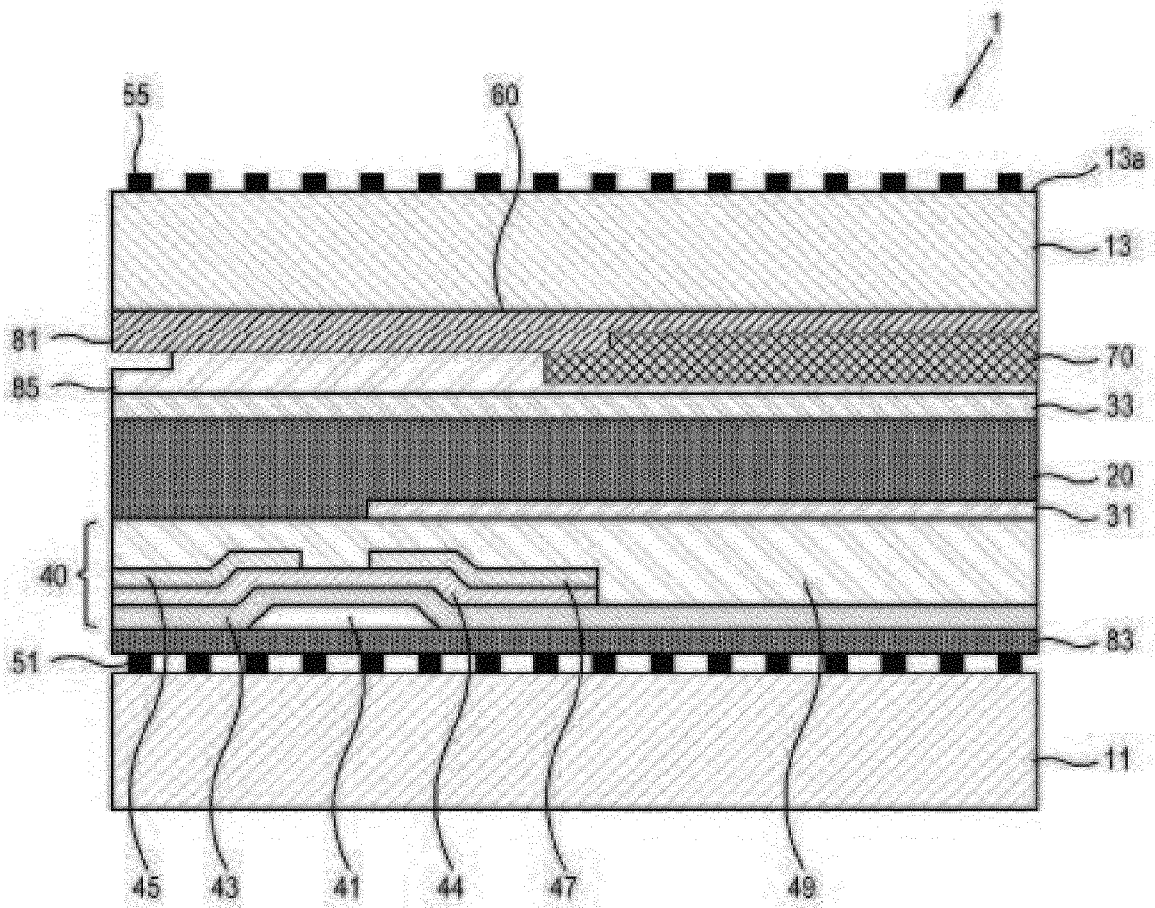

FIG. 5

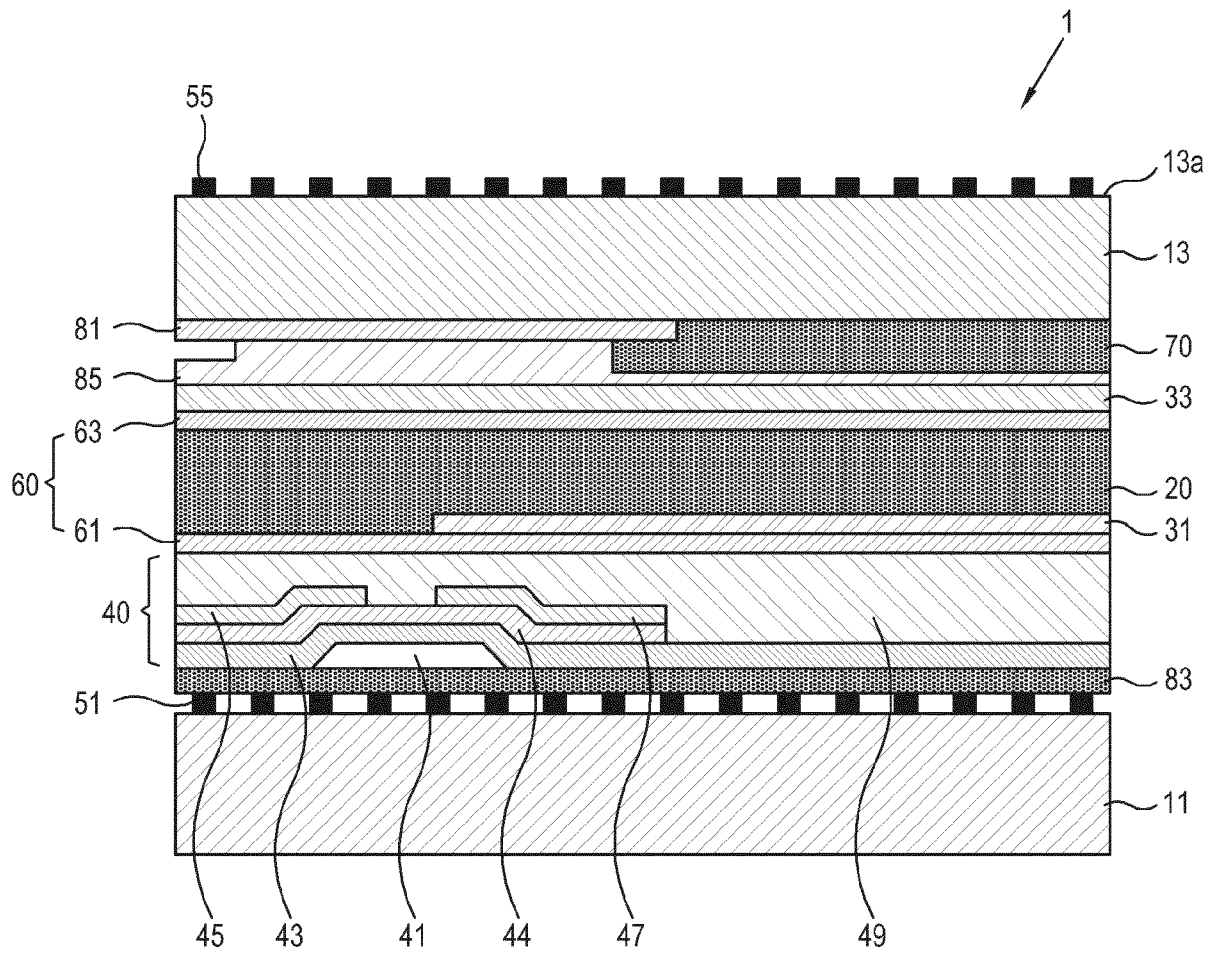

FIG. 6

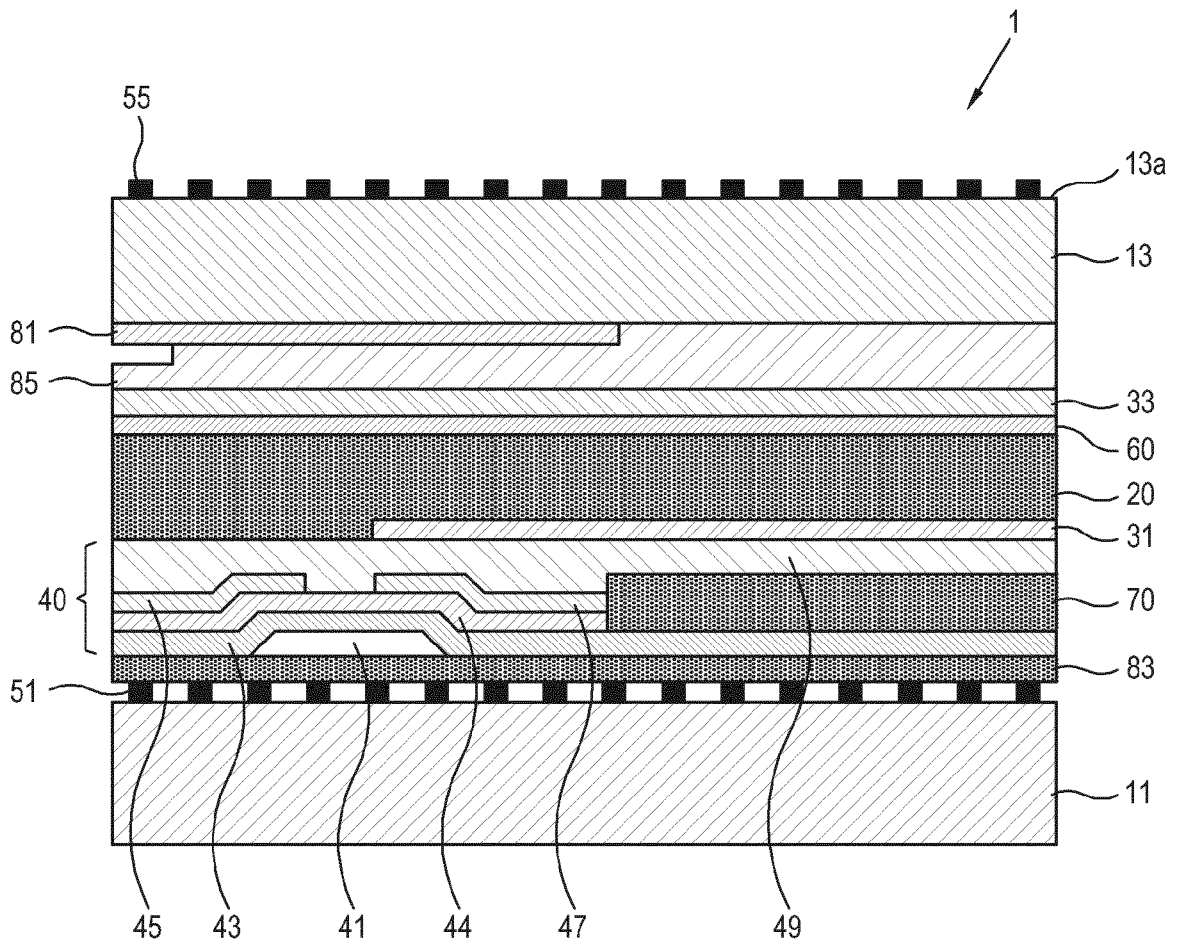
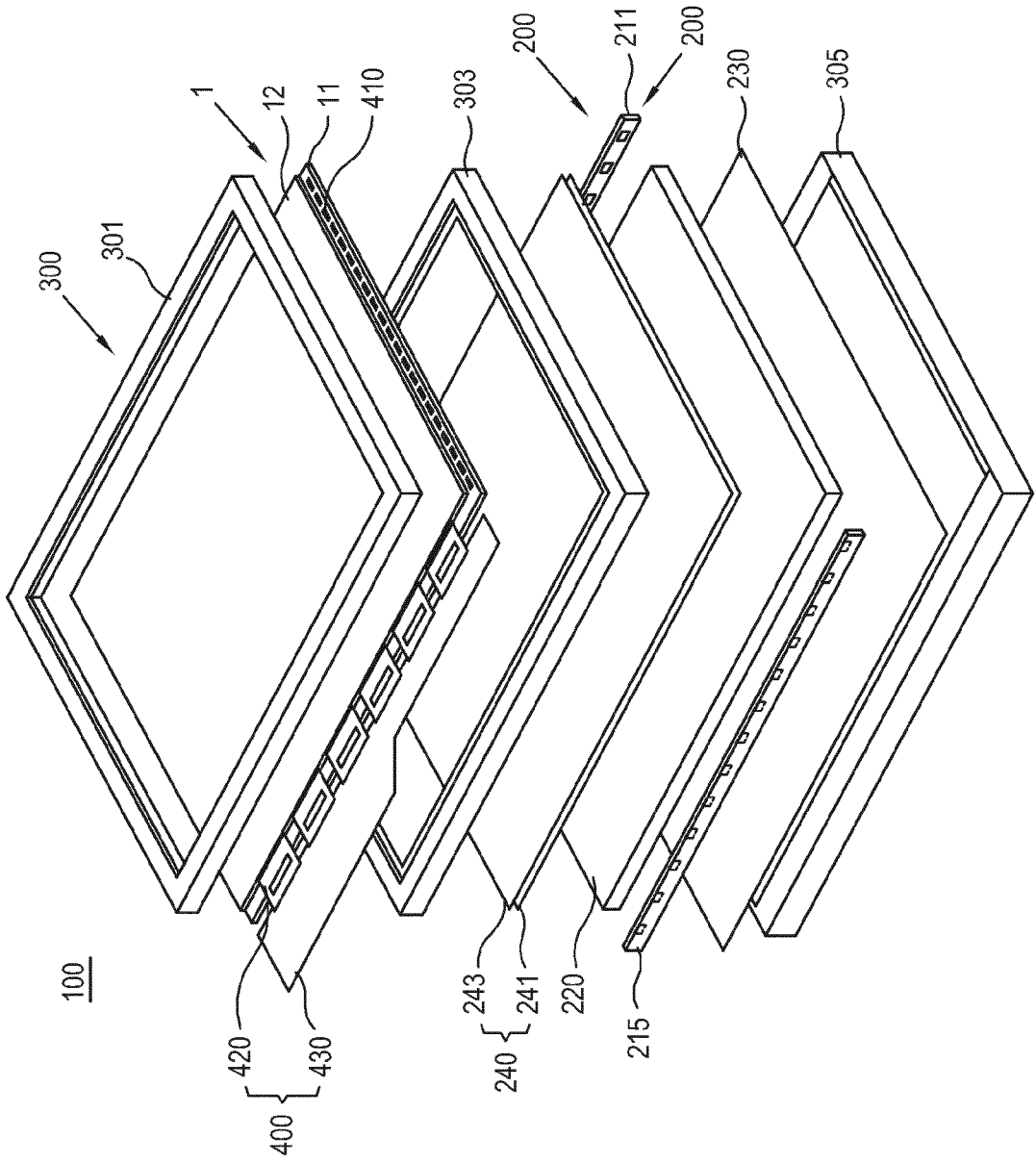

FIG. 7





EUROPEAN SEARCH REPORT

Application Number  
EP 12 16 2562

DOCUMENTS CONSIDERED TO BE RELEVANT			
Category	Citation of document with indication, where appropriate, of relevant passages	Relevant to claim	CLASSIFICATION OF THE APPLICATION (IPC)
X	JP 2007 108436 A (FUJIFILM CORP) 26 April 2007 (2007-04-26)	1,2,4, 6-8,11, 15	INV. G02F1/1335
Y	* the whole document *	3,5,9, 10,12,14	
X	EP 1 980 899 A2 (SUMITOMO CHEMICAL CO [JP]) 15 October 2008 (2008-10-15)	1,2,4,6	
Y	* paragraphs [0029], [0035], [0046] - [0056]; claims; figure 1 *	3,5,7-15	
Y	US 2008/100781 A1 (CHOO DAE HO [KR] ET AL) 1 May 2008 (2008-05-01) * figures 2,3 *	3,5,7-15	
Y	US 2008/037094 A1 (HWANG KYU-HWAN [KR] ET AL) 14 February 2008 (2008-02-14) * paragraphs [0048] - [0066]; figures 1-3 *	14	
			TECHNICAL FIELDS SEARCHED (IPC)
			G02F
The present search report has been drawn up for all claims			
Place of search Munich		Date of completion of the search 24 August 2012	Examiner Kiernan, Laurence
CATEGORY OF CITED DOCUMENTS X : particularly relevant if taken alone Y : particularly relevant if combined with another document of the same category A : technological background O : non-written disclosure P : intermediate document		T : theory or principle underlying the invention E : earlier patent document, but published on, or after the filing date D : document cited in the application L : document cited for other reasons & : member of the same patent family, corresponding document	

1  
EPC FORM 1503 03.82 (P04C01)

**ANNEX TO THE EUROPEAN SEARCH REPORT  
ON EUROPEAN PATENT APPLICATION NO.**

EP 12 16 2562

This annex lists the patent family members relating to the patent documents cited in the above-mentioned European search report. The members are as contained in the European Patent Office EDP file on  
The European Patent Office is in no way liable for these particulars which are merely given for the purpose of information.

24-08-2012

Patent document cited in search report	Publication date	Patent family member(s)	Publication date
JP 2007108436 A	26-04-2007	NONE	
EP 1980899 A2	15-10-2008	AT 408171 T AT 472747 T CN 101010622 A EP 1789838 A1 EP 1980899 A2 JP 2008511854 A KR 20070059073 A US 2008043329 A1 WO 2006025002 A1	15-09-2008 15-07-2010 01-08-2007 30-05-2007 15-10-2008 17-04-2008 11-06-2007 21-02-2008 09-03-2006
US 2008100781 A1	01-05-2008	KR 20080037324 A US 2008100781 A1	30-04-2008 01-05-2008
US 2008037094 A1	14-02-2008	JP 4694541 B2 JP 2008046637 A US 2008037094 A1	08-06-2011 28-02-2008 14-02-2008

专利名称(译)	显示面板和包括该显示面板的显示设备		
公开(公告)号	<a href="#">EP2555044A1</a>	公开(公告)日	2013-02-06
申请号	EP2012162562	申请日	2012-03-30
[标]申请(专利权)人(译)	三星电子株式会社		
申请(专利权)人(译)	SAMSUNG ELECTRONICS CO. , LTD.		
当前申请(专利权)人(译)	SAMSUNG ELECTRONICS CO. , LTD.		
[标]发明人	CHUNG SEONG EUN JUNG IL YONG		
发明人	CHUNG, SEONG-EUN JUNG, IL-YONG		
IPC分类号	G02F1/1335		
CPC分类号	G02F1/133528 G02F2001/133548 G02F2001/133565 G02F2001/133638		
优先权	1020110077477 2011-08-03 KR		
外部链接	<a href="#">Espacenet</a>		

摘要(译)

提供一种显示面板和包括该显示面板的显示装置，其采用线栅偏振片。显示面板包括：第一和第二基板；液晶层，介于第一和第二基板之间；第一和第二电极分别插在第一基板和液晶层之间以及液晶层和第二基板之间，并向液晶层供电；第一和第二线栅偏振片，其形成在第一和第二基板中的每一个的表面上并允许偏振光透过其中；以及相位差补偿膜，其插入在第一和第二线栅偏振片之间并补偿入射光的相位差。

FIG. 1

