



(12) **EUROPEAN PATENT APPLICATION**

(43) Date of publication: **04.10.2001 Bulletin 2001/40** (51) Int Cl.<sup>7</sup>: **G09G 3/36**

(21) Application number: **01302925.1**

(22) Date of filing: **28.03.2001**

(84) Designated Contracting States:  
**AT BE CH CY DE DK ES FI FR GB GR IE IT LI LU  
MC NL PT SE TR**  
Designated Extension States:  
**AL LT LV MK RO SI**

(72) Inventors:  
• **Miyajima, Yasushi**  
**Gifu-shi, Gifu (JP)**  
• **Koga, Masayuki**  
**Anpachi-gun, Gifu (JP)**

(30) Priority: **28.03.2000 JP 2000087770**

(74) Representative:  
**Cross, Rupert Edward Blount et al**  
**BOULT WADE TENNANT,**  
**Verulam Gardens**  
**70 Gray's Inn Road**  
**London WC1X 8BT (GB)**

(71) Applicant: **Sanyo Electric Co., Ltd.**  
**Moriguchi-shi, Osaka (JP)**

(54) **Display device of active matrix type**

(57) When a gate voltage having a rectangular-shaped pulse is supplied, the voltage of a pixel electrode is pulled down and fluctuated by a fall of the gate voltage due to a parasitic capacitor formed between a gate line and the pixel electrode, i.e. a so-called drop voltage is generated. As the drop voltage depends on a time constant of a change in the gate voltage, it can be dimin-

ished by smoothing the falling edge of the gate voltage. This is achieved by, for example, providing a current discharging transistor of a gate driver 8 with a small channel width to decrease the maximum current value. By utilizing such a gate voltage, a liquid crystal display device with a small drop voltage can be provided, even when the capacitance of the parasitic capacitor is great.

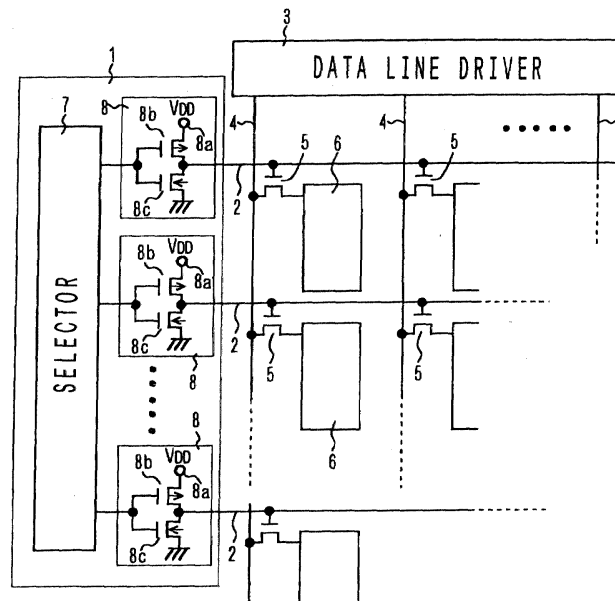

Fig. 2

**Description**

## BACKGROUND OF THE INVENTION

## 5 1. Field of the Invention

[0001] The present invention relates to a display device of an active matrix type provided with a plurality of pixel electrodes arranged in a matrix and each connected to a thin film transistor (hereinafter referred to as a "TFT") as a switching element, and more particularly to a liquid crystal display (LCD) having an improved gate line driver.

## 10 2. Description of the Related Art

[0002] Fig. 1 shows an equivalent circuit diagram for one pixel in an LCD. A pixel TFT 5 connected to a gate line 2 and a data line 4 is connected to a pixel electrode 6. The pixel electrode 6 forms a capacitor  $C_{LC}$  with an opposite electrode Vcom with liquid crystal 11 interposed therebetween. A storage capacitor  $C_{SC}$  is provided in parallel to the liquid crystal capacitor  $C_{LC}$  to maintain a voltage applied to the pixel electrode 6. While it is intended that the circuit have the above-described configuration, a parasitic capacitor  $C_{GS}$  is generated between the gate and the source (the pixel electrode 6) of the TFT and increase in capacitance of the parasitic capacitor  $C_{GS}$  results in problems, such as fluctuation in potential of the pixel electrode 6 due to the effects of a gate voltage applied to the gate line 2. In conventional devices, the effects of the parasitic capacitor  $C_{GS}$  are reduced by providing a storage capacitor  $C_{SC}$  with sufficient capacitance to account for that of the parasitic capacitor  $C_{GS}$ .

[0003] In recent years, LCDs have come to be widely used for display devices in portable electronic devices, such as, for example, for viewfinders in digital still cameras and digital video cameras. LCDs for such portable devices must be made fine with a reduced display size while maintaining the number of pixels.

[0004] When a display size is reduced, the area of the pixel electrode is reduced, as is the electrode for forming the storage capacitor  $C_{SC}$ . As a result, the capacitances of the liquid crystal capacitor  $C_{LC}$  and the storage capacitor  $C_{SC}$  are decreased. On the other hand, because the processible minimum line width is fixed, it is difficult to reduce the capacitance of the parasitic capacitor  $C_{GS}$  beyond a certain level. Thus, when the LCD is made fine, the parasitic capacitor  $C_{GS}$  has a relatively greater capacitance as compared to the liquid crystal capacitor  $C_{LC}$  and the storage capacitor  $C_{SC}$ .

[0005] Such an increase in capacitance of the parasitic capacitor  $C_{GS}$  gives rise to an increase of a so-called drop voltage  $\Delta V$ , i.e. the potential of the pixel electrode fluctuates because it is pulled down by a fall of the gate voltage. When the drop voltage  $\Delta V$  is increased, various problems occur, such as generation of a difference in luminance between columns when liquid crystal is driven by an alternating voltage, and deviation of a central value Vc of a voltage applied to the pixel electrode from the potential Vcom of the opposite electrode.

## SUMMARY OF THE INVENTION

[0006] Therefore, an object of the present invention is to provide an LCD capable of avoiding an increase of the drop voltage  $\Delta V$  even when the capacitance of the parasitic capacitor  $C_{GS}$  becomes greater as compared to the liquid crystal capacitor  $C_{LC}$  and the storage capacitor  $C_{SC}$ , to thereby maintain the display quality of a finely manufactured LCD.

[0007] The present invention has been conceived in view of the above-described problems, and an active matrix type display device according to one aspect of the invention includes a plurality of gate lines; a plurality of data lines crossing said plurality of gate lines; a plurality of pixel electrodes; a thin film transistor disposed at each intersection between said plurality of gate lines and said plurality of data lines, and including a gate electrode and an active region, said gate electrode being connected to one of said plurality of gate lines, and said active region having a first region connected to one of said plurality of data lines, and a second region connected to a corresponding one of said plurality of pixel electrodes; and a gate line driver for sequentially applying a gate selection signal with a pulse-shaped voltage waveform to a selected one of said plurality of gate lines, wherein said gate line driver causes a falling edge of said gate selection signal with said pulse-shaped voltage waveform to be smoother, or less sharp, than a rising edge thereof.

[0008] Alternatively, according to the present invention, said gate line driver causes a falling time of said gate selection signal with said pulse-shaped voltage waveform to be longer than a corresponding rising time.

[0009] As described above, according to the present invention, a gate voltage having a less sharp falling edge is applied, whereby a drop voltage  $\Delta V$  resulting from fluctuation of the gate voltage is suppressed to only a small value. As a result, an active matrix type liquid crystal display device with a high display quality can be provided.

[0010] According to another aspect of the present invention, in an active matrix type display device as described above, said gate selection signal requires at least a time period of  $t/2$  to fall, where  $t$  is a time period from the time a first gate line assumes an unselected state to the time a subsequent second gate line assumes a selected state.

[0011] According to still another aspect of the present invention, in an active matrix type display device as above, said gate selection signal falls over a time at least ten times that required for rise.

[0012] By thus providing a sufficiently long period of time for the gate selection signal to fall, the drop voltage  $\Delta V$  can be suppressed to a sufficiently low value.

5 [0013] According to a further aspect of the present invention, in an active matrix type display device as above, said gate line driver includes a gate buffer provided at a final stage and connected to a corresponding one of said plurality of gate lines. The gate buffer includes a transistor having first and second regions of an active layer respectively connected to the ground and said corresponding gate line. Further, the condition,  $2.5(R1+R2)*(C1+C2) < t < 5(R1+R2) * (C1+C2)$ , is satisfied, where R1 represents a total resistance of said gate line and the gate electrodes of the thin film transistors connected to said gate line in a pixel region, C1 represents a total capacitance of capacitors connected to said gate line in the pixel region and having said gate line as one electrode, R2 represents a channel resistance of the transistor in said gate buffer, C2 represents a capacitance of a capacitor formed by said active layer of the transistor in said gate buffer and the gate electrode of said transistor, and t represents a flyback period within a horizontal scanning period.

15 [0014] According to a further aspect of the present invention, in the above active matrix type display device, a channel length L and a channel width W of the transistor in said gate buffer satisfy a condition of  $W/L < 1$ .

[0015] According to a further aspect of the present invention, in an active matrix type display device as above, said gate line driver includes a gate buffer provided at a final stage and connected to a corresponding one of said plurality of gate lines, said gate buffer including a current supplying transistor having first and second regions of an active layer connected between a power source and said corresponding gate line and a current discharging transistor having first and second regions of an active layer respectively connected to the ground and said corresponding gate line, and the ratio (channel width W)/(channel length L) of said current supplying transistor is different from the ratio (channel width W)/(channel length L) of said current discharging transistor.

25 [0016] According to a further aspect of the present invention, in an active matrix type display device as above, the channel length L and the channel width W of the current discharging transistor in said gate buffer satisfy the condition that  $W/L < 1$ .

[0017] According to a further aspect of the present invention, in an active matrix type display device as above, the condition that the ratio of (the ratio W/L of said current supplying transistor) / (the ratio W/L of said current discharging transistor) is greater than 1 is satisfied.

30 [0018] According to a further aspect of the present invention, in an active matrix type display device as above, a condition that the ratio of (the ratio W/L of said current supplying transistor) / (the ratio W/L of said current discharging transistor) is greater than 5 is satisfied.

[0019] By thus designing respective circuit elements to satisfy the above conditions, it can be ensured that the gate voltage will fall within a predetermined time, and the drop voltage  $\Delta V$  can be suppressed.

35 [0020] Further, as the ratio W/L of the transistor in the gate buffer, especially the current discharging transistor, is smaller than 1, the maximum allowable amount of current for this transistor can be reduced and the gate voltage (gate selection signal) can be provided with a blunted falling edge.

#### BRIEF DESCRIPTION OF THE DRAWINGS

40 [0021] Fig. 1 is an equivalent circuit diagram of one pixel of a liquid crystal display device.

[0022] Fig. 2 is a plan view illustrating a liquid crystal display device according to the present invention.

[0023] Figs. 3(a), 3(b), and 3(c) show pulse waveforms supplied to a gate line.

[0024] Fig. 4 shows timing charts of voltages applied to a data line and the gate line.

45 [0025] Fig. 5 shows a change in a voltage  $\Delta V$  with the ratio between vertical and horizontal dimensions of a gate buffer transistor.

#### DESCRIPTION OF THE PREFERRED EMBODIMENTS

50 [0026] Preferred embodiments of the present invention will next be described.

[0027] Fig. 2 is a plan view showing an active matrix LCD according to the present invention. A plurality of gate lines 2 extending in a row direction are connected to a gate line driver 1, while a plurality of data lines 4 extending in a column direction are connected to a data line driver 3. A pixel electrode 6 is connected to an intersection between the gate line 2 and the data line 4 through a pixel TFT 5.

55 [0028] The gate line driver 1 includes a selector 7 for selecting one of a plurality of gate buffers 8, each applying a gate voltage to the gate line 2. The selector 7 selects one of the plurality of gate buffers 8, and outputs a signal "High" to the selected buffer 8 and a signal "Low" to the rest of the buffers 8.

[0029] Each of the gate buffers 8 includes a p-channel thin film transistor (hereinafter referred to as a "p-ch transistor")

8b, and an n-channel thin film transistor (hereinafter referred to as an "n-ch transistor") 8c. These transistors form a CMOS configuration, and are connected in series between a power source 8a and the ground. The transistors 8b and 8c have a gate electrode receiving an output from the selector 7, and a node between the CMOS transistors 8b and 8c is connected to the corresponding gate line 2. When one of the outputs of the selector 7 is rendered "Low", in the gate buffer 8 receiving that output, the p-ch transistor 8b functioning as a current supplying (source) transistor is turned on while the n-ch transistor 8c functioning as a current discharging (sink) transistor is turned off, so that a power source voltage VDD is supplied from the power source to the gate line 2 through the p-ch transistor 8b. As a result, all the pixel TFTs 5 connected to that gate line 2 are turned on, allowing data to be written in the pixel electrodes 6.

**[0030]** The data line driver 3 is connected to the plurality of data lines 4, and applies a data voltage corresponding to a displayed video image to each of the data lines 4. As the pixel TFT 5 connected to the selected gate line 2 has an open gate, the data voltage applied to the data line 4 is written in the pixel electrode 6 through the pixel TFT 5. The image is then displayed by changing alignment of the liquid crystal corresponding to the pixel electrodes 6.

**[0031]** After a predetermined period (specifically, one horizontal scanning period) has elapsed, the selector 7 selects another one of the gate buffers 8 for selecting the gate line 2 in the next row. In other words, the selector 7 outputs "High" to the gate buffer 8 which has been selected up to that moment, thereby turning off the p-ch transistor, and, instead, turning on the n-ch transistor. As a result, the corresponding gate line 2 is dropped to a ground potential, thereby turning off the gate of each pixel TFT 5.

**[0032]** The characteristic feature of this embodiment lies in the pulse waveform of the gate voltage. Fig. 3(a) shows a pulse waveform of a gate voltage that has conventionally been regarded as an ideal waveform. This pulse waveform is a rectangular waveform rising vertically at a first time point T1 and falling vertically at a second time point T2. On the other hand, the present embodiment utilizes a gate voltage having a characteristic pulse waveform in Fig. 3(b) in which edge sharpness is reduced. That is, as shown in Fig. 3(b), the waveform in which the voltage rises at the first time T1, begins to fall at the second time T2, and completes falling at a third time T3 is ideal in this embodiment.

**[0033]** When a gate voltage having a pulse in such a waveform is supplied, reduction in the drop voltage  $\Delta V$  can be achieved. Because the drop voltage  $\Delta V$  is a function of a time constant of a voltage change, the drop voltage  $\Delta V$  is reduced when the gate voltage gradually changes, as in the waveforms in Figs. 3(b) and 3(c).

**[0034]** Next, a method of reducing the sharpness of the falling edge of the gate voltage will be described. Fig. 4 shows timing charts of a data voltage (a) applied to a given data line in driving the LCD by an alternating voltage, a gate voltage (b) applied to a given gate line, and a gate voltage (c) applied to a gate line located in the next row from the gate line related to the voltage (b). A time period T during which the gate voltage is ON is a so-called writing period in which the TFT 5 is turned on causing the data voltage to be applied to the pixel electrode 6 and the voltage is boosted. After a flyback period t provided in each horizontal scanning period has elapsed, data is written in the pixel electrode 6 in the next row. The gate voltage falls during the flyback period t, and the gate voltage for the next row rises in synchronism with the next writing period T. When the LCD is driven by the voltage having a pulse in the waveform in Fig. 3(a) (which actually has a slightly blunt edge), a time period required for the gate voltage to fall is approximately  $t/100$ , where t is the flyback period. In contrast, the gate voltage in this application gradually falls in a period of approximately  $t/2$ .

**[0035]** As -the time required for the gate voltage to rise is approximately  $t/100$ , a time 50 times as long as this rising time is required for the gate voltage to fall.

**[0036]** Naturally, the voltage  $\Delta V$  can further be reduced if the gate voltage falls in a period greater than  $t/2$ . If the time period required for the fall exceeds the period t, however, application of the data voltage to the pixel TFT 5 in the next row is started, hindering image display operation. Therefore, the time period required for the fall must be shorter than the period t. Further, considering variation in the falling time period among the respective pixel TFTs 5 resulting from variation of the pixel TFTs 5 generated during fabrication, the voltage is preferably set to fall in a period of  $t/2$ .

**[0037]** Generally, a voltage drop observed when an electric circuit releases electric charges is proportional to  $e^{-(t/RC)}$ , where R is the resistance of the circuit and C is the capacitance thereof. Regarding the voltage drop of the gate line 2:

$R = (\text{resistance of the selected gate line 2}) + (\text{overall resistance of the gate electrodes of all the pixel TFTs 5 connected to the selected gate line 2}) + (\text{channel resistance of the n-ch transistor 8c of the gate buffer 8});$  and  
 $C = (\text{capacitance of the capacitor formed by the selected gate line 2 and another electrode and the like}) + (\text{overall capacitance of the capacitors formed by the gate electrodes of all the pixel TFTs 5 connected to that gate line 2}) + (\text{capacitance of the gate-source and gate-drain capacitors of the n-ch transistor 8c of the gate buffer 8}).$

Assuming that the gate of the pixel TFT 5 is closed (i.e. the TFT is turned off) when the gate voltage falls to one tenth of the applied voltage or lower, the condition for the gate to close within the flyback period is:

$$t < 5(R_1+R_2) \cdot (C_1+C_2),$$

where

R1 = the total of the resistance of the gate line and the overall resistance of the gate electrodes of the pixel TFTs connected thereto;

C1 = the total of the capacitances of the capacitors formed by the gate line and the data line, the gate line and the opposite electrode, and an active layer of the thin film transistor connected to the pixel electrode and the gate electrode;

R2 = channel resistance of the n-ch transistor 8c of the gate buffer;

C2 = capacitance of the capacitor formed by the active layer of the thin film transistor of the gate buffer and the gate electrode; and

t = time period from the time application of the voltage to the pixel electrode is ended to the time application of the voltage to the electrode in the next row is started: horizontal flyback period.

The flyback period t is determined by the driving frequency and the number of pixels of the LCD, and the values R1 and C1 are determined by the number of pixels and size of the LCD. By properly designing the n-ch transistor 8c of the gate buffer 8, the values R2 and C2 can be adjusted to satisfy the condition defined by the above expression. Further, the gate voltage can fall bluntly within a predetermined period by designing the n-ch transistor 8c to satisfy the following condition:

$$2.5(R1+R2) \cdot (C1+C2) < t < 5(R1+R2) \cdot (C1+C2)$$

**[0038]** The time required for the gate voltage to fall is described as the flyback period t above. However, when, for example, the data line 4 is precharged to a predetermined voltage before the data voltage is applied, the time given as the gate voltage falling period is reduced from the above flyback period. In such a case, the flyback period t used in the above description should be replaced with the period from the time application of the data voltage is ended to the time precharging is started. In other words, the voltage of the pixel TFT 5 must fall completely before precharging is started, and the gate buffer must be designed so that the voltage gradually falls within this time period.

**[0039]** A specific method of applying a gate voltage having a blunted waveform will next be described. Referring to Fig. 2, when the output of the selector 7 is rendered "L", the gate of the transistor 8b is turned on, whereby a selection signal (gate voltage) is applied to the gate line 2 from the power source 8a through the transistor 8b, and the gate voltage rises at the selected gate line 2. For causing the gate voltage to fall, the output of the selector 7 is rendered "H", turning on the transistor 8c, through which the electric charges accumulated at the gate line 2 are released. At this time, the maximum current discharged from the transistor 8c is set to a small value, thereby setting the amount of time required to completely release the electric charges to a value such that the sharpness of the falling edge of the gate voltage can be reduced. Thus, in the present embodiment, bluntness of the gate voltage is adjusted by setting the maximum current in the transistor 8c.

**[0040]** The maximum amount of current in a transistor is generally smaller for a greater gate length L and a smaller gate width W. Therefore, the maximum amount of current in a transistor is reduced as the ratio W/L between the gate length and the gate width is made smaller. Fig. 5 shows variation of the voltage  $\Delta V$  with change in the ratio W/L of the n-ch transistor while the ratio W/L of the p-ch transistor is maintained. Although the value  $\Delta V$  is changed by various factors, such as the size of the LCD and thickness of films, the change shown in Fig. 5 is obtained when all these parameters are fixed. It can be seen from the figure that the drop voltage  $\Delta V$  decreases with a decrease in the ratio W/L of the n-ch transistor, i.e. it decreases as the width becomes smaller as compared to the length.

**[0041]** As illustrated in Fig. 2, the gate buffer is configured by combining the p-ch transistor and the n-ch transistor. The present invention is characterized in the smoother, less sharp falling edge of the gate voltage. For the rise of the gate voltage, as a longer time period is secured for application of the data voltage to the gate electrode if the voltage rises earlier, the pulse waveform in Fig. 3(b) is the most ideal waveform. The gate voltage is caused to rise by applying the power source voltage VDD to each of the gate lines 2 through the switched-on p-ch transistor 8b, and is caused to fall by connecting the gate line 2 to the ground through the turned-on n-ch transistor 8c for discharge. Therefore, the pulse waveform in Fig. 3(b) can be achieved by setting a greater value for the maximum allowable current in the p-ch transistor (source transistor) 8b, and by setting the maximum allowable current in the n-ch transistor (sink transistor) 8c smaller than the value for the above source transistor 8b. For such a setting, the ratio W/L of the p-ch transistor of the gate buffer is significantly different from that of the n-ch transistor. For example, the two W/L ratios are set as follows:

$$\text{p-ch transistor's W/L ratio} : \text{n-ch transistor's W/L ratio} = 10:1$$

It should be noted, however, that if sufficient time is secured to write data in the pixel electrode, the gate voltage may have a smoothed rising edge, as in the waveform in Fig. 3(c).

[0042] As an alternative method of smoothing the edge of the gate voltage, a resistor or a capacitor may be disposed between the gate buffer 8 and the gate line 2. With such a configuration, however, the sharpness of the rising edge of the gate voltage is also smoothed, as in the waveform shown in Fig. 3(c). Although such a waveform may create no problem when a sufficiently long writing period can be provided, the entire pulse is delayed when the edge is smoothed using resistors or capacitors.

[0043] While the present invention can be implemented in a variety of LCDs regardless of their size, the advantages are more prominent in a small-sized LCD, as will be described. As the gate line 2 has a predetermined resistance, the gate voltage is provided with different degrees of sharpness between the TFT 5 located closer to the gate driver 8 and the TFT 5 farther from the gate driver 8, and a delay of the selection signal becomes greater as the TFT 5 is located farther from the driver 8. Such a difference is more prominent in a larger LCD because the gate line 2 is longer. On the other hand, the gate line 2 is short in a small-sized LCD, such as a 2-inch or smaller LCD or a 0.55 inch or smaller LCD used for viewfinders and the like, and therefore the delay caused by resistance of the gate line 2 does not normally lead to any significant problems. On the other hand, the problem of the relatively greater capacitance of the parasitic capacitor is especially conspicuous in small-sized LCDs. Consequently, the advantages of the present invention are most effective when the invention is applied to small-sized LCDs.

## Claims

### 1. An active matrix type display device, comprising:

a plurality of gate lines;  
 a plurality of data lines crossing said plurality of gate lines;  
 a plurality of pixel electrodes;  
 a thin film transistor disposed at each intersection between said plurality of gate lines and said plurality of data lines, and including a gate electrode and an active region, said gate electrode being connected to one of said plurality of gate lines, and said active region having a first region connected to one of said plurality of data lines, and a second region connected to a corresponding one of said plurality of pixel electrodes; and  
 a gate line driver for sequentially applying a gate selection signal with a pulse-shaped voltage waveform to a selected one of said plurality of gate lines; wherein  
 said gate line driver causes a falling edge of said gate selection signal with said pulse-shaped voltage waveform to be smoother than a rising edge thereof.

### 2. An active matrix type display device, comprising:

a plurality of gate lines;  
 a plurality of data lines crossing said plurality of gate lines;  
 a plurality of pixel electrodes;  
 a thin film transistor disposed at each intersection between said plurality of gate lines and said plurality of data lines, and including a gate electrode and an active region, said gate electrode being connected to one of said plurality of gate lines, and said active region having a first region connected to one of said plurality of data lines and a second region connected to a corresponding one of said plurality of pixel electrodes; and  
 a gate line driver for sequentially applying a gate selection signal with a pulse-shaped voltage waveform to a selected one of said plurality of gate lines; wherein  
 said gate line driver causes a falling time of said gate selection signal to be longer than a rising time thereof.

### 3. The active matrix type display device according to claim 1 or 2, wherein said gate selection signal requires at least a time $t/2$ to fall, where $t$ is the time from when a first gate line assumes an unselected state to the when a subsequent second gate line assumes a selected state.

### 4. The active matrix type display device according to claim 1 or 2, wherein said gate selection signal falls over a time at least ten times the time required for the signal to rise.

### 5. The active matrix type display device according to any one of claims 1-4, wherein

said gate line driver includes a gate buffer provided at a final stage and connected to a corresponding one of

said plurality of gate Lines,  
 said gate buffer includes a transistor having first and second regions of an active layer respectively connected to the ground and to said corresponding gate line, and  
 a condition,  $2.5(R1+R2)*(C1+C2) < t < 5(R1+R2)*(C1+C2)$ , is satisfied, wherein  
 5 R1 represents a total resistance of said gate line and the gate electrodes of the thin film transistors connected to said gate line in a pixel region,  
 C1 represents a total capacitance of capacitors connected to said gate line in the pixel region and having said gate line as one electrode,  
 10 R2 represents a channel resistance of the transistor in said gate buffer,  
 C2 represents a capacitance of a capacitor formed by said active layer of the transistor in said gate buffer and the gate electrode of said transistor, and  
 t represents a flyback period in a horizontal scanning period.

6. The active matrix type display device according to claim 5, wherein a channel length L and a channel width W of the transistor in said gate buffer satisfy the condition  $W/L < 1$ .

7. The active matrix type display device according to any one of claims 1-4, wherein

20 said gate line driver includes a gate buffer provided at a final stage and connected to a corresponding one of said plurality of gate lines,  
 said gate buffer includes a transistor having first and second regions of an active layer respectively connected to the ground and to said corresponding gate line, and  
 a channel length L and a channel width W of the transistor in said gate buffer satisfy the condition  $W/L < 1$ .

8. The active matrix type display device according to any one of claims 1-4, wherein

30 said gate line driver includes a gate buffer provided at a final stage and connected to a corresponding one of said plurality of gate lines,  
 said gate buffer includes a current supplying transistor having first and second regions of an active layer connected between a power source and said corresponding gate line and a current discharging transistor having first and second regions of an active layer respectively connected to the ground and to said corresponding gate line, and  
 the ratio (channel width W)/(channel length L) of said current supplying transistor differs from the ratio (channel width W)/(channel length L) of said current discharging transistor.

9. The active matrix type display device according claim 8, wherein

40 the condition,  $2.5(R1+R2)*(C1+C2) < t < 5(R1+R2)*(C1+C2)$ , is satisfied, wherein  
 R1 represents a total resistance of said gate line and the gate electrodes of the thin film transistors connected to said gate line in a pixel region,  
 C1 represents a total capacitance of capacitors connected to said gate line in the pixel region and having said gate line as one electrode,  
 45 R2 represents a channel resistance of the current discharging transistor in said gate buffer,  
 C2 represents a capacitance of a capacitor formed by said active layer of the current discharging transistor in said gate buffer and the gate electrode thereof, and  
 t represents a flyback period in a horizontal scanning period.

10. The active matrix type display device according to claim 8 or 9, wherein the channel length L and the channel width W of the current discharging transistor in said gate buffer satisfy the condition  $W/L < 1$ .

11. The active matrix type display device according to any one of claims 8-10, wherein the condition that the ratio of (the ratio W/L of said current supplying transistor) / (the ratio W/L of said current discharging transistor) is greater than 1 is satisfied.

12. The active matrix type display device according to any one of claims 8-10, wherein the condition that the ratio of (the ratio W/L of said current supplying transistor) / (the ratio W/L of said current discharging transistor) is greater than 5 is satisfied.

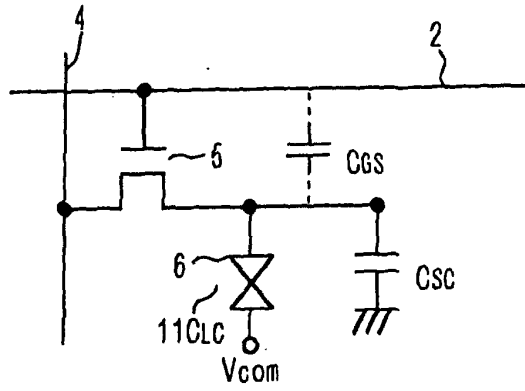

Fig. 1

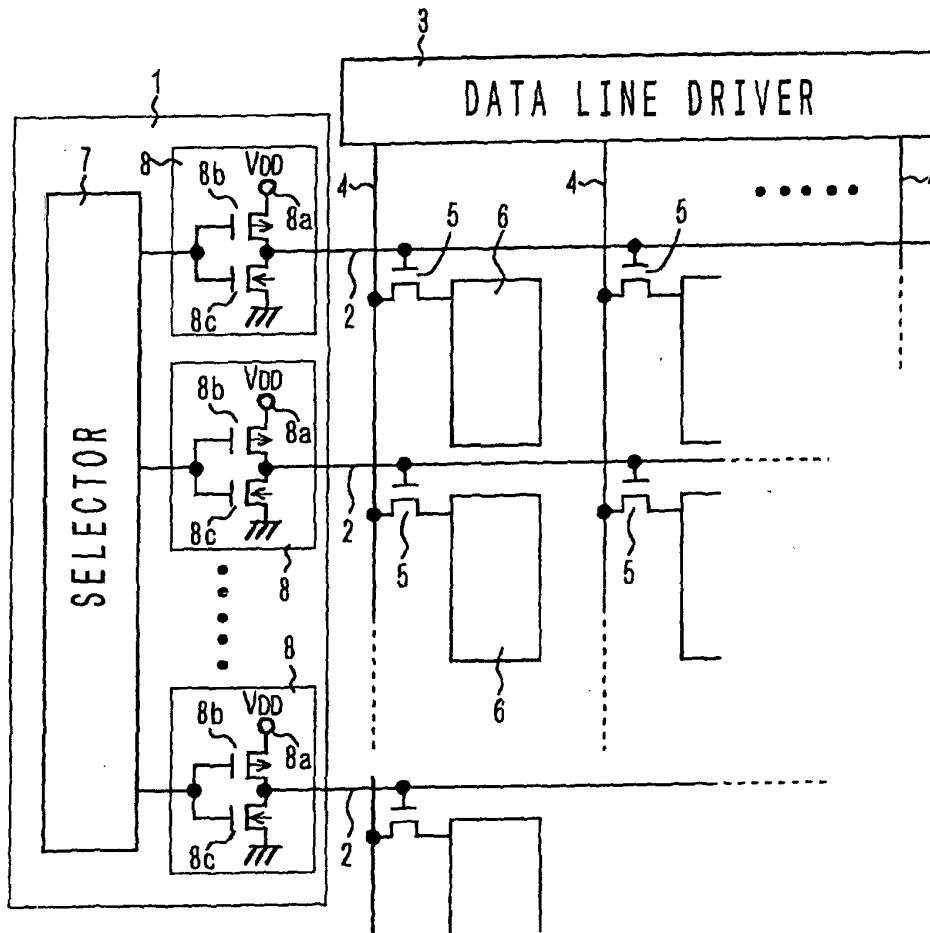

Fig. 2

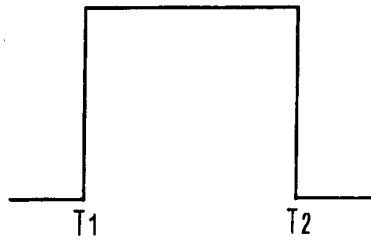

Fig. 3(a)

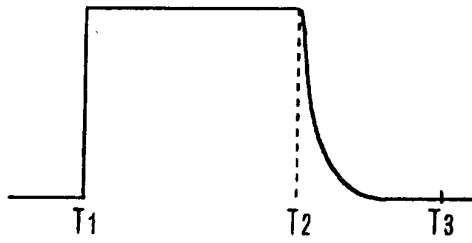

Fig. 3(b)

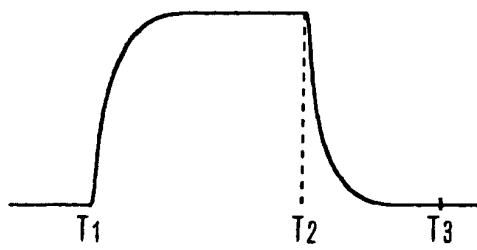

Fig. 3(c)

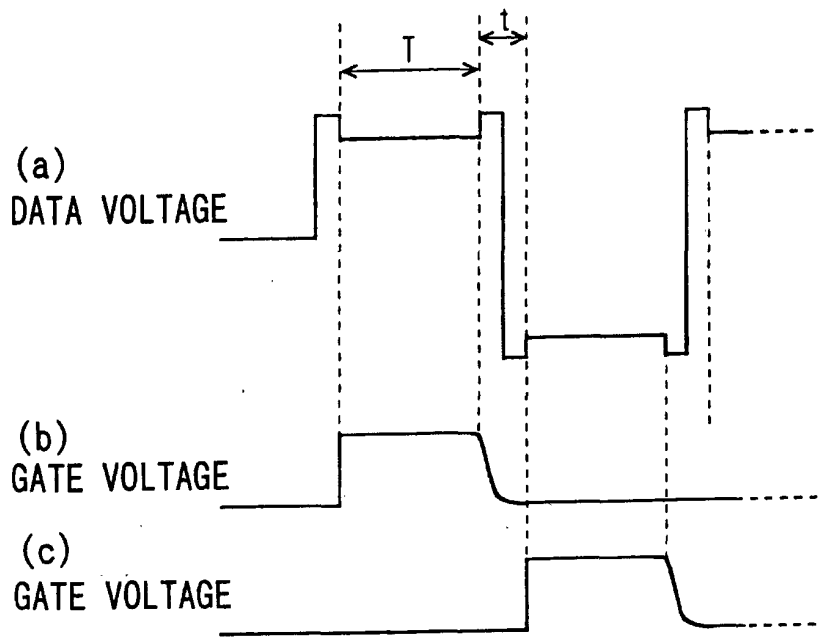

Fig. 4

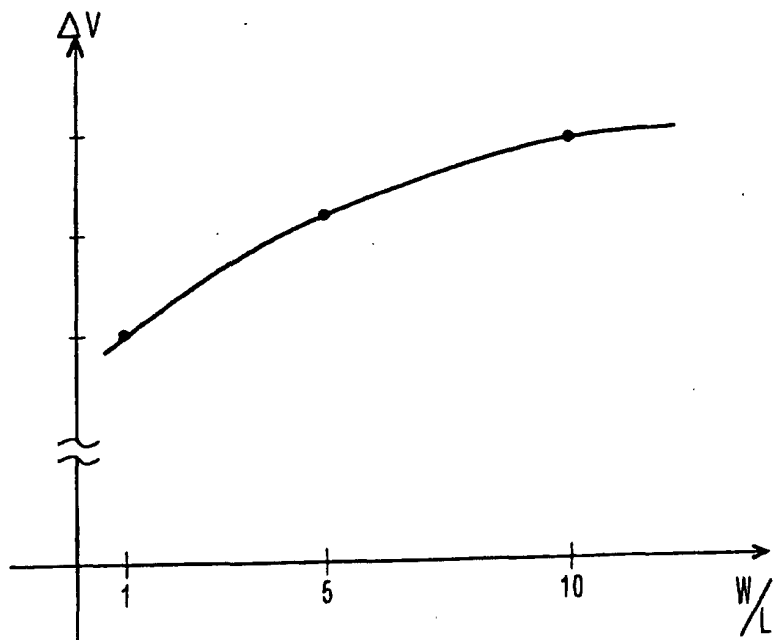

Fig. 5

专利名称(译)	有源矩阵型显示装置		
公开(公告)号	<a href="#">EP1139329A2</a>	公开(公告)日	2001-10-04
申请号	EP2001302925	申请日	2001-03-28
[标]申请(专利权)人(译)	三洋电机株式会社		
申请(专利权)人(译)	SANYO ELECTRIC CO. , LTD.		
当前申请(专利权)人(译)	SANYO ELECTRIC CO. , LTD.		
[标]发明人	MIYAJIMA YASUSHI KOGA MASAYUKI		
发明人	MIYAJIMA, YASUSHI KOGA, MASAYUKI		
IPC分类号	G02F1/136 G02F1/133 G02F1/1368 G09G3/20 G09G3/36 H01L29/786		
CPC分类号	G09G3/3677 G09G2310/066 G09G2320/0219		
优先权	2000087770 2000-03-28 JP		
其他公开文献	EP1139329A3		
外部链接	<a href="#">Espacenet</a>		

摘要(译)

当提供具有矩形脉冲的栅极电压时，由于栅极线和像素电极之间形成的寄生电容器，即由此产生的栅极电压的下降，像素电极的电压被下拉并波动。称为降压产生。由于下降电压取决于栅极电压变化的时间常数，因此可以通过平滑栅极电压的下降沿来减小它。这是通过例如提供具有小沟道宽度的栅极驱动器8的电流放电晶体管以减小最大电流值来实现的。通过利用这样的栅极电压，即使寄生电容器的电容很大，也可以提供具有小的压降电压的液晶显示装置。

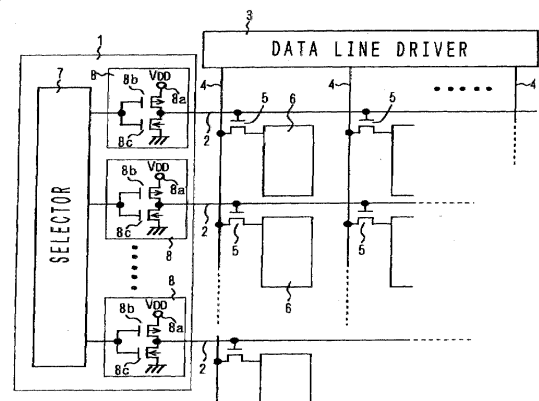

Fig. 2