

(19)



(11)

EP 2 796 922 B1

(12)

EUROPEAN PATENT SPECIFICATION

(45) Date of publication and mention of the grant of the patent:

05.10.2016 Bulletin 2016/40

(21) Application number: **13798537.0**

(22) Date of filing: **21.02.2013**

(51) Int Cl.:

G02F 1/1335 (2006.01)	C09K 19/12 (2006.01)
C09K 19/20 (2006.01)	C09K 19/30 (2006.01)
C09K 19/34 (2006.01)	C09K 19/38 (2006.01)
C09K 19/54 (2006.01)	G02B 5/20 (2006.01)
G02F 1/13 (2006.01)	C09K 19/44 (2006.01)
C09K 19/04 (2006.01)	G02F 1/1333 (2006.01)

(86) International application number:

PCT/JP2013/054351

(87) International publication number:

WO 2014/128885 (28.08.2014 Gazette 2014/35)

(54) **LIQUID CRYSTAL DISPLAY DEVICE**

FLÜSSIGKRISTALLANZEIGEVORRICHTUNG

DISPOSITIF D’AFFICHAGE À CRISTAUX LIQUIDES

(84) Designated Contracting States:

AL AT BE BG CH CY CZ DE DK EE ES FI FR GB GR HR HU IE IS IT LI LT LU LV MC MK MT NL NO PL PT RO RS SE SI SK SM TR

(43) Date of publication of application:

29.10.2014 Bulletin 2014/44

(73) Proprietor: **DIC Corporation**

Tokyo 174-8520 (JP)

(72) Inventors:

- **KURIYAMA, Takeshi**
Saitama 3628577 (JP)
- **KAWAMURA, Jouji**
Saitama 3628577 (JP)
- **KIMURA, Akira**
Ibaraki 3140193 (JP)

• **FUNAKURA, Seiji**

Ibaraki 3140193 (JP)

• **SHIMADA, Katsunori**

Chiba 2858668 (JP)

(74) Representative: **Adam, Holger et al**

Kraus & Weisert

Patentanwälte PartGmbB

Thomas-Wimmer-Ring 15

80539 München (DE)

(56) References cited:

WO-A1-2010/095506	JP-A- 2000 192 040
JP-A- 2009 163 014	JP-A- 2010 256 509
US-A1- 2010 097 562	US-A1- 2011 058 138
US-B1- 8 178 173	

EP 2 796 922 B1

Note: Within nine months of the publication of the mention of the grant of the European patent in the European Patent Bulletin, any person may give notice to the European Patent Office of opposition to that patent, in accordance with the Implementing Regulations. Notice of opposition shall not be deemed to have been filed until the opposition fee has been paid. (Art. 99(1) European Patent Convention).

Description

Technical Field

5 [0001] The present invention relates to a liquid crystal display device.

Background Art

10 [0002] Liquid crystal display devices have been used for clocks, calculators, household electric appliances, measuring instruments, panels for automobiles, word processors, electronic organizers, printers, computers, and televisions. Typical examples of a liquid crystal display mode include a TN (twisted nematic) mode, an STN (super twisted nematic) mode, a DS (dynamic scattering) mode, a GH (guest-host) mode, an IPS (in-plane switching) mode, an OCB (optically compensated birefringence) mode, an ECB (electrically controlled birefringence) mode, a VA (vertical alignment) mode, a CSH (color super-homeotropic) mode, and FLC (ferroelectric liquid crystal). The driving method has been changed from
15 conventional static driving to multiplex driving, and passive matrix driving and, recently, active matrix (AM) driving performed using, for example, TFTs (thin film transistors) and TFDs (thin film diodes) have become the predominantly used driving method.

[0003] As shown in Fig. 1, typical color liquid crystal display devices include two substrates (1) each having an alignment film (4), a transparent electrode layer (3a) serving as a common electrode and a color filter layer (2) disposed between
20 one of the substrates and its alignment film, and a pixel electrode layer (3b) disposed between the other of the substrates and its alignment film. The substrates are disposed so that the alignment films face each other, and a liquid crystal layer (5) is sandwiched between the alignment films.

[0004] The color filter layer includes a black matrix and a color filter constituted by a red colored layer (R), a green colored layer (G), a blue colored layer (B), and optionally a yellow colored layer (Y).

25 [0005] A liquid crystal material constituting the liquid crystal layer has been highly controlled in terms of impurities because impurities left in the liquid crystal material considerably affect the electrical characteristics of a display device. It has been also known that, regarding a material of the alignment film, the alignment film directly contacts the liquid crystal layer and therefore impurities left in the alignment film moves to the liquid crystal layer, which affects the electrical characteristics of the liquid crystal layer. Thus, the characteristics of liquid crystal display devices resulting from impurities
30 in the material of the alignment film are being studied.

[0006] Similarly to the alignment film material, a material such as an organic pigment used for the color filter layer is also assumed to affect the liquid crystal layer because of impurities contained in the material. However, it has been considered that, since there are an alignment film and a transparent electrode between the color filter layer and the liquid crystal layer, the direct influence of impurities on the liquid crystal layer is much smaller than the influence of
35 impurities contained in the alignment film material. However, in general, the alignment film has a thickness of merely 0.1 μm or less, and even a common electrode which serves as a transparent electrode and is used on the color filter layer side and whose thickness is increased to increase the electrical conductivity has a thickness of merely 0.5 μm or less. Therefore, the color filter layer and the liquid crystal layer are not present in an environment in which they are completely isolated. The color filter layer may cause display defects such as white streaks, alignment unevenness, and image sticking because the voltage holding ratio (VHR) of the liquid crystal layer is decreased and the ion density (ID)
40 is increased due to impurities contained in the color filter layer, the impurities affecting the liquid crystal layer through the alignment film and transparent electrode.

[0007] To overcome the display defects caused by impurities contained in a pigment constituting the color filter, the following methods have been studied: a method for controlling the elution of impurities that move into liquid crystal by
45 using a pigment in which the proportion of an extract resulting from ethyl formate is adjusted to a particular value or less (JP 2000-19321 A) and a method for controlling the elution of impurities that move into liquid crystal by specifying a pigment in a blue colored layer (JP 2009-109542 A). However, these methods are not so different from a method in which the amount of impurities in a pigment is simply decreased. In a current situation in which a purification technique of pigments has advanced, these methods do not provide a sufficient improvement to overcome the display defects.

50 [0008] On the other hand, focusing on the relationship between a liquid crystal composition and organic impurities contained in a color filter, there are disclosed a method in which the difficulty of dissolving the organic impurities in the liquid crystal layer is expressed as a hydrophobic parameter of liquid crystal molecules in the liquid crystal layer, and the hydrophobic parameter is set to be equal to or more than a particular value; and a method in which, with consideration of a correlation between the hydrophobic parameter and an $-\text{OCF}_3$ group at the liquid crystal molecule terminal, a liquid
55 crystal composition containing, at a certain proportion or more, a liquid crystal compound having an $-\text{OCF}_3$ group at the liquid crystal molecule terminal is prepared (JP 2000-192040 A).

[0009] However, in the disclosure of JP 2000-192040 A, the essence of the invention is also to suppress the influence of impurities in a pigment on the liquid crystal layer. The direct relationship between a structure of a liquid crystal material

and a structure of a coloring material such as a dye/pigment used for a color filter has not been studied, which does not overcome the problems of display defects of highly advanced liquid crystal display devices.

[0010] Among further prior art, US 8,178,173 B1 discloses a TBA-liquid crystal display panel including a liquid crystal medium with positive dielectric anisotropy. Furthermore, US 2011/0058138 A1 discloses a liquid crystal display including a first substrate, a second substrate and a liquid crystal layer. Moreover, US 2010/0097562 A1 discloses a liquid crystal composition including two non-polar liquid crystal compounds.

Summary of Invention

Technical Problem

[0011] The present invention provides a liquid crystal display device in which a decrease in the voltage holding ratio (VHR) of a liquid crystal layer and an increase in the ion density (ID) are prevented and problems of display defects such as white streaks, alignment unevenness, and image sticking are overcome by using a particular liquid crystal composition and a color filter that uses a particular dye and/or pigment.

Solution to Problem

[0012] To solve the above problems, the inventors of the present invention have conducted thorough studies on the combination between a coloring material such as a dye/pigment constituting the color filter and a structure of a liquid crystal material constituting the liquid crystal layer. As a result, the inventors have found that, in a liquid crystal display device including a particular liquid crystal material structure and a color filter that uses a dye and/or pigment having a particular structure, a decrease in the voltage holding ratio (VHR) of a liquid crystal layer and an increase in the ion density (ID) are prevented and problems of display defects such as white streaks, alignment unevenness, and image sticking are overcome. Thus, the present invention has been completed.

[0013] That is, the present invention provides a liquid crystal display device including a first substrate, a second substrate, a liquid crystal composition layer sandwiched between the first substrate and the second substrate, a color filter constituted by a black matrix and at least RGB three color pixel portions, a pixel electrode, and a common electrode, wherein the liquid crystal composition layer contains a liquid crystal composition containing at least one compound represented by general formula (I),

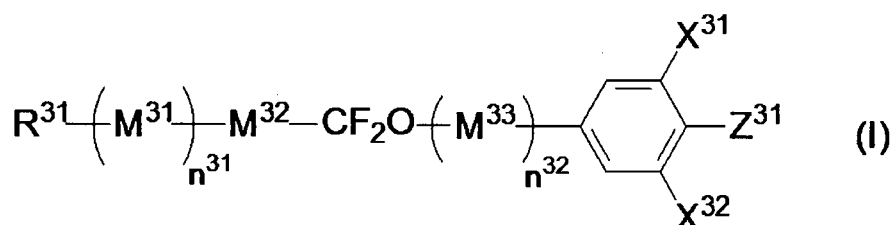

in general formula, R^{31} represents an alkyl group or alkoxy group having 1 to 10 carbon atoms or an alkenyl group or alkenyloxy group having 2 to 10 carbon atoms, M^{31} to M^{33} each independently represent a trans-1,4-cyclohexylene group or a 1,4-phenylene group, one or two $-CH_2-$ in the trans-1,4-cyclohexylene group may be substituted with $-O-$ unless oxygen atoms directly bond to each other, one or two hydrogen atoms in the phenylene group may be substituted with a fluorine atom, X^{31} and X^{32} each independently represent a hydrogen atom or a fluorine atom, Z^{31} represents a fluorine atom, a trifluoromethoxy group, or a trifluoromethyl group, n^{31} and n^{32} each independently represent 0, 1, or 2, $n^{31} + n^{32}$ represents 0, 1, or 2, and when a plurality of M^{31} or M^{33} are present, the plurality of M^{31} may be the same or different or the plurality of M^{33} may be the same or different, and at least one compound selected from the group consisting of compounds represented by general formula (II-a) to general formula (II-e),

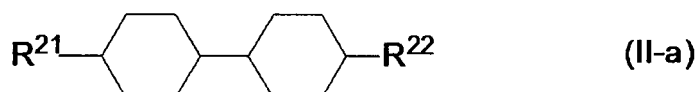

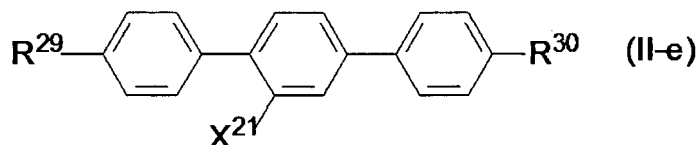
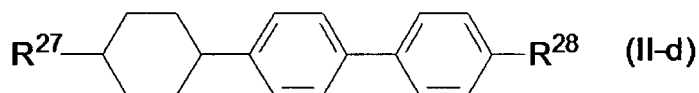
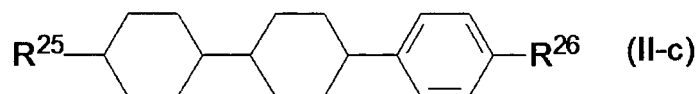
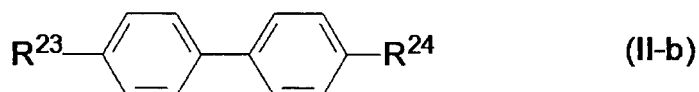

in general formulae, R²¹ to R³⁰ each independently represent an alkyl group having 1 to 10 carbon atoms or an alkenyl group having 2 to 10 carbon atoms, and X²¹ represents a hydrogen atom or a fluorine atom;

the RGB three color pixel portions contain, in a G pixel portion as a coloring material, a halogenated metal phthalocyanine pigment having a central metal selected from the group consisting of Al, Si, Sc, Ti, V, Mg, Fe, Co, Ni, Zn, Ga, Ge, Y, Zr, Nb, In, Sn, and Pb; when the central metal is a trivalent metal, any one of a halogen atom, a hydroxyl group, and a sulfonic acid group bonds to the central metal or the central metal forms an oxo-bridge or thio-bridge; and, when the central metal is a tetravalent metal, a single oxygen atom or any two of a halogen atom, a hydroxyl group, and a sulfonic acid group which may be the same or different bond to the central metal.

Advantageous Effects of Invention

[0014] According to the liquid crystal display device of the present invention, a decrease in the voltage holding ratio (VHR) of a liquid crystal layer and an increase in the ion density (ID) can be prevented and display defects such as white streaks, alignment unevenness, and image sticking can be prevented by using a particular liquid crystal composition and a color filter that uses a particular pigment.

Brief Description of Drawings

[0015]

[Fig. 1] Fig. 1 is a diagram showing an example of a known typical liquid crystal display device.

[Fig. 2] Fig. 2 is a diagram showing an example of a liquid crystal display device of the present invention. Reference Signs List

[0016]

- 1 substrate
- 2 color filter layer
- 2a color filter layer containing a particular pigment
- 3a transparent electrode layer (common electrode)
- 3b pixel electrode layer
- 4 alignment film
- 5 liquid crystal layer
- 5a liquid crystal layer containing a particular liquid crystal composition

Description of Embodiments

[0017] Fig. 2 shows an example of a liquid crystal display device of the present invention. First and second substrates (1) each have an alignment film (4). A transparent electrode layer (3a) serving as a common electrode and a color filter layer (2a) containing a particular pigment are disposed between one of the substrates and its alignment film. A pixel electrode layer (3b) is disposed between the other of the substrates and its alignment film. The substrates are disposed so that the alignment films face each other. A liquid crystal layer (5a) containing a particular liquid crystal composition is sandwiched between the alignment films.

[0018] The two substrates in the display device are laminated with a sealing material disposed in a peripheral region. In many cases, a particulate spacer or a columnar spacer composed of a resin and formed by photolithography is disposed between the substrates to keep the distance between the substrates.

(Liquid crystal composition layer)

[0019] A liquid crystal composition layer in the liquid crystal display device of the present invention contains a liquid crystal composition containing at least one compound represented by general formula (I),

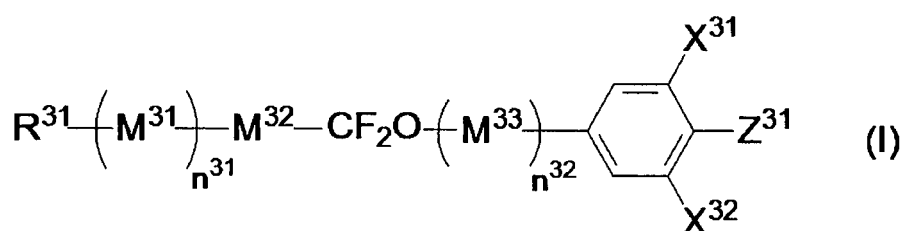

in general formula, R^{31} represents an alkyl group or alkoxy group having 1 to 10 carbon atoms or an alkenyl group or alkenyloxy group having 2 to 10 carbon atoms, M^{31} to M^{33} each independently represent a trans-1,4-cyclohexylene group or a 1,4-phenylene group, one or two $-CH_2-$ in the trans-1,4-cyclohexylene group may be substituted with $-O-$ unless oxygen atoms directly bond to each other, one or two hydrogen atoms in the phenylene group may be substituted with a fluorine atom, X^{31} and X^{32} each independently represent a hydrogen atom or a fluorine atom, Z^{31} represents a fluorine atom, a trifluoromethoxy group, or a trifluoromethyl group, n^{31} and n^{32} each independently represent 0, 1, or 2, $n^{31} + n^{32}$ represents 0, 1, or 2, and when a plurality of M^{31} or M^{33} are present, the plurality of M^{31} may be the same or different or the plurality of M^{33} may be the same or different, and at least one compound selected from the group consisting of compounds represented by general formula (II-a) to general formula (II-e),

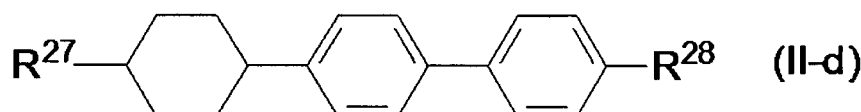
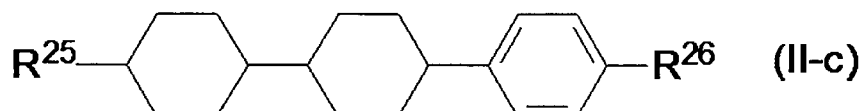
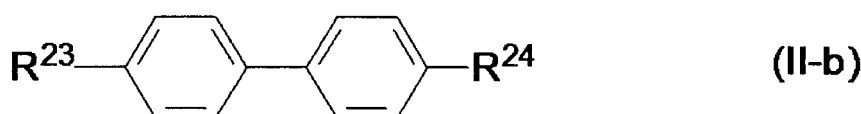
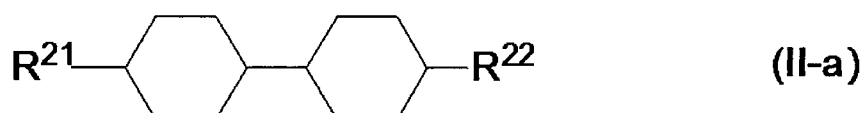

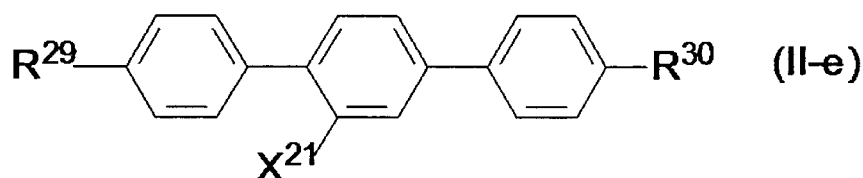

in general formulae, R^{21} to R^{30} each independently represent an alkyl group having 1 to 10 carbon atoms or an alkenyl group having 2 to 10 carbon atoms, and X^{21} represents a hydrogen atom or a fluorine atom.

10 **[0020]** In general formula (I), when the ring structure to which R^{31} bonds is a phenyl group (aromatic group), R^{31} preferably represents a linear alkyl group having 1 to 5 carbon atoms, a linear alkoxy group having 1 to 4 (or more) carbon atoms, or an alkenyl group having 4 or 5 carbon atoms. When the ring structure to which R^{31} bonds is a saturated ring structure such as cyclohexane, pyran, or dioxane, R^{31} preferably represents a linear alkyl group having 1 to 5 carbon atoms, a linear alkoxy group having 1 to 4 (or more) carbon atoms, or a linear alkenyl group having 2 to 5 carbon atoms.

15 **[0021]** When an importance is given to good chemical stability to heat and light, R^{31} preferably represents an alkyl group. When an importance is given to production of a liquid crystal display element having high response speed due to low viscosity, R^{31} preferably represents an alkenyl group. Furthermore, for the purpose of decreasing the viscosity, increasing the nematic-isotropic phase transition temperature (T_{ni}), and further improving the response speed, an alkenyl group whose terminal bond is not an unsaturated bond is preferably used and an alkenyl group having a methyl group bonded to the terminal of the alkenyl group is particularly preferably used. When an importance is given to high solubility at low temperature, R^{31} preferably represents an alkoxy group as one solution strategy. In another solution strategy, multiple types of R^{31} are preferably used together. For example, R^{31} is preferably a combination of compounds having alkyl groups or alkenyl groups having 2, 3, and 4 carbon atoms, a combination of compounds having alkyl groups or alkenyl groups having 3 and 5 carbon atoms, or a combination of compounds having alkyl groups or alkenyl groups having 3, 4, and 5 carbon atoms. M^{31} to M^{33} preferably have the following structures.

20

25

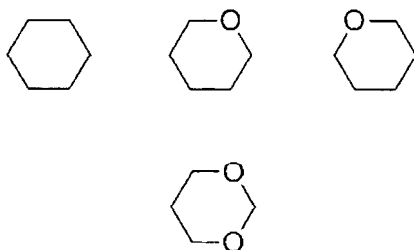
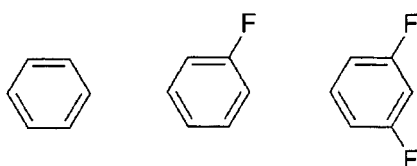

45 M^{31} preferably has the following structures.

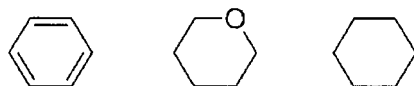

50 M^{31} more preferably has the following structures.



55 M^{32} preferably has the following structures.

EP 2 796 922 B1

5

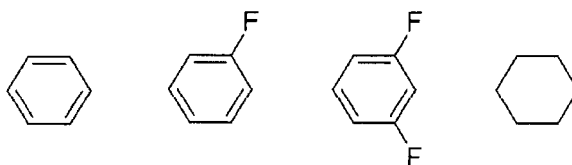

M³² more preferably has the following structures.

10

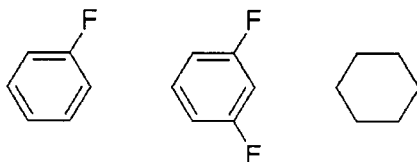

15

M³² further preferably has the following structures.

20

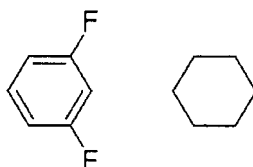

25

M³³ preferably has the following structures.

30

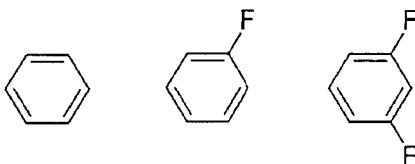

35

M³³ more preferably has the following structures.

40

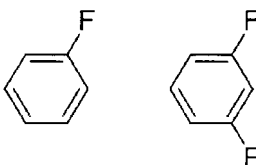

45

M³³ further preferably has the following structure.

50

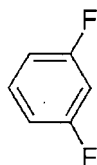

55

[0022] At least one of X³¹ and X³² preferably represents a fluorine atom and both of X³¹ and X³² more preferably represent fluorine atoms.

[0023] Z³¹ preferably represents a fluorine atom or a trifluoromethoxy group.

[0024] Regarding the combination of X³¹, X³², and Z³¹, in one embodiment, X³¹ = F, X³² = F, and Z³¹ = F. In another embodiment, X³¹ = F, X³² = H, and Z³¹ = F. In still another embodiment, X³¹ = F, X³² = H, and Z³¹ = OCF₃. In still

another embodiment, $X^{31} = F$, $X^{32} = F$, and $Z^{31} = OCF_3$. In still another embodiment, $X^{31} = H$, $X^{32} = H$, and $Z^{31} = OCF_3$. n^{31} preferably represents 1 or 2, n^{32} preferably represents 0 or 1 and more preferably 0, and $n^{31} + n^{32}$ preferably represents 1 or 2 and more preferably 2.

[0025] More specifically, the compound represented by general formula (I) preferably includes compounds represented by general formula (I-a) to general formula (I-f) below.

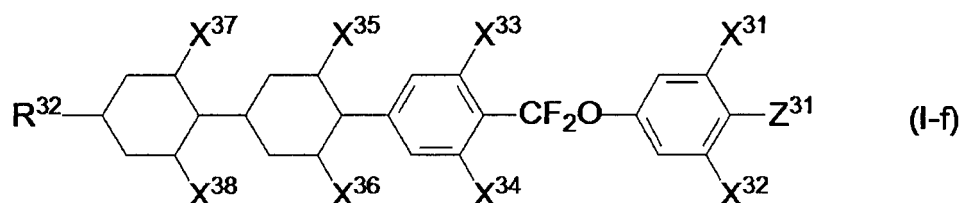
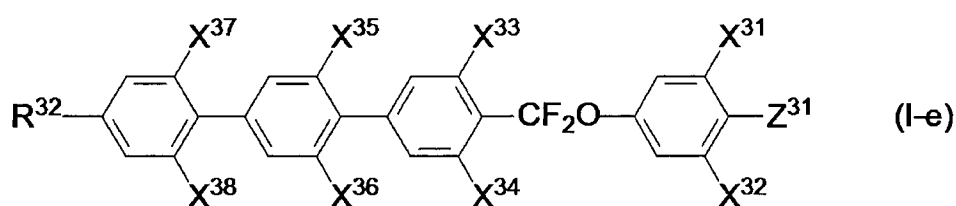
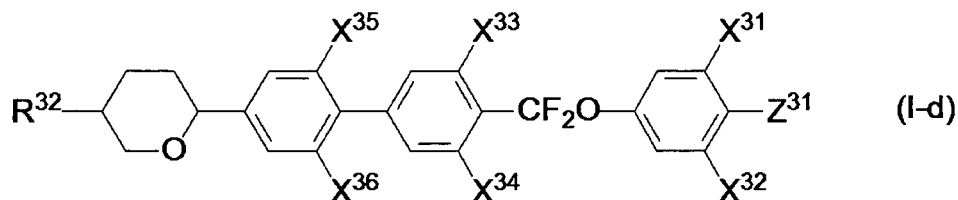
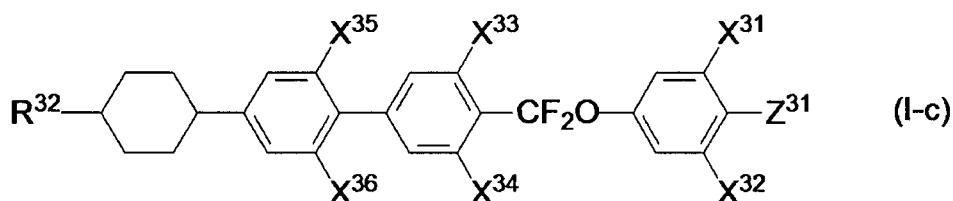
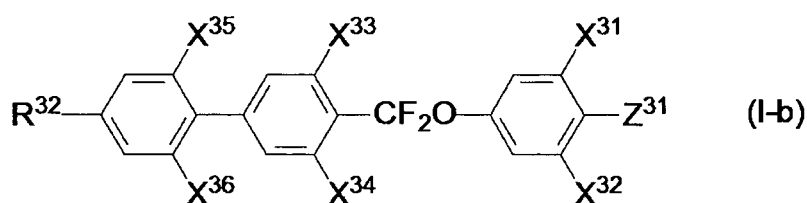
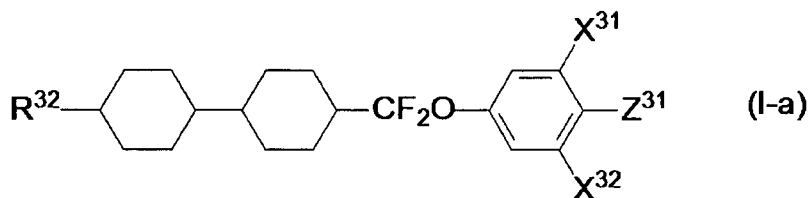

[0026] (In general formulae, R^{32} represents an alkyl group or alkoxy group having 1 to 10 carbon atoms or an alkenyl group or alkenyloxy group having 2 to 10 carbon atoms, X^{31} to X^{38} each independently represent a hydrogen atom or a fluorine atom, and Z^{31} represents a fluorine atom, a trifluoromethoxy group, or a trifluoromethyl group.)

[0027] In general formula (I-a) to general formula (I-f), when the ring structure to which R^{32} bonds is a phenyl group

(aromatic group), R^{32} preferably represents a linear alkyl group having 1 to 5 carbon atoms, a linear alkoxy group having 1 to 4 (or more) carbon atoms, or an alkenyl group having 4 or 5 carbon atoms. When the ring structure to which R^{32} bonds is a saturated ring structure such as cyclohexane, pyran, or dioxane, R^{32} preferably represents a linear alkyl group having 1 to 5 carbon atoms, a linear alkoxy group having 1 to 4 (or more) carbon atoms, or a linear alkenyl group having 2 to 5 carbon atoms.

[0028] When an importance is given to good chemical stability to heat and light, R^{31} preferably represents an alkyl group. When an importance is given to production of a liquid crystal display element having high response speed due to low viscosity, R^{31} preferably represents an alkenyl group. Furthermore, for the purpose of decreasing the viscosity, increasing the nematic-isotropic phase transition temperature (T_{ni}), and further improving the response speed, an alkenyl group whose terminal bond is not an unsaturated bond is preferably used and an alkenyl group having a methyl group bonded to the terminal of the alkenyl group is particularly preferably used. When an importance is given to high solubility at low temperature, R^{31} preferably represents an alkoxy group as one solution strategy. In another solution strategy, multiple types of R^{31} are preferably used together. For example, R^{31} is preferably a combination of compounds having alkyl groups or alkenyl groups having 2, 3, and 4 carbon atoms, a combination of compounds having alkyl groups or alkenyl groups having 3 and 5 carbon atoms, or a combination of compounds having alkyl groups or alkenyl groups having 3, 4, and 5 carbon atoms.

[0029] At least one of X^3 and X^{32} preferably represents a fluorine atom and both of X^3 and X^{32} more preferably represent fluorine atoms.

[0030] Z^{31} preferably represents a fluorine atom or a trifluoromethoxy group.

[0031] Regarding the combination of X^{31} , X^{32} and Z^{31} , in one embodiment, $X^{31} = F$, $X^{32} = F$, and $Z^{31} = F$. In another embodiment, $X^{31} = F$, $X^{32} = H$, and $Z^{31} = F$. In still another embodiment, $X^{31} = F$, $X^{32} = H$, and $Z^{31} = OCF_3$. In still another embodiment, $X^{31} = F$, $X^{31} = F$, and $Z^{31} = OCF_3$. In still another embodiment, $X^{31} = H$, $X^{31} = H$, and $Z^{31} = OCF_3$. n^{31} preferably represents 1 or 2, n^{32} preferably represents 0 or 1 and more preferably 0, and $n^{31} + n^{32}$ preferably represents 1 or 2 and more preferably 2.

[0032] At least one of X^{33} and X^{34} preferably represents a fluorine atom and both of X^{33} and X^{34} more preferably represent fluorine atoms.

[0033] At least one of X^{35} and X^{36} preferably represents a fluorine atom. However, it is not preferred that both of X^{35} and X^{36} represent fluorine atoms in view of T_{ni} , solubility at low temperature, and chemical stability in the form of a liquid crystal display element, though there is a good effect when $\Delta\epsilon$ is increased.

[0034] At least one of X^{37} and X^{38} preferably represents a hydrogen atom and both of X^{37} and X^{38} more preferably represent hydrogen atoms. It is not preferred that at least one of X^{37} and X^{38} represent a fluorine atom in view of T_{ni} , solubility at low temperature, and chemical stability in the form of a liquid crystal display element.

[0035] One to eight of the compounds represented by general formula (I) are preferably contained and one to five of the compounds are particularly preferably contained. The content of the compounds is preferably 3% to 50% by mass and more preferably 5% to 40% by mass.

[0036] In general formula (II-a) to general formula (II-e), when the ring structure to which each of R^{21} to R^{30} bonds is a phenyl group (aromatic group), each of R^{21} to R^{30} preferably represents a linear alkyl group having 1 to 5 carbon atoms, a linear alkoxy group having 1 to 4 (or more) carbon atoms, or an alkenyl group having 4 or 5 carbon atoms. When the ring structure to which each of R^{21} to R^{30} bonds is a saturated ring structure such as cyclohexane, pyran, or dioxane, each of R^{21} to R^{30} preferably represents a linear alkyl group having 1 to 5 carbon atoms, a linear alkoxy group having 1 to 4 (or more) carbon atoms, or a linear alkenyl group having 2 to 5 carbon atoms.

[0037] When an importance is given to good chemical stability to heat and light, each of R^{21} to R^{30} preferably represents an alkyl group. When an importance is given to production of a liquid crystal display element having high response speed due to low viscosity, each of R^{21} to R^{30} preferably represents an alkenyl group. Furthermore, for the purpose of decreasing the viscosity, increasing the nematic-isotropic phase transition temperature (T_{ni}), and further improving the response speed, an alkenyl group whose terminal bond is not an unsaturated bond is preferably used and an alkenyl group having a methyl group bonded to the terminal of the alkenyl group is particularly preferably used. When an importance is given to high solubility at low temperature, each of R^{21} to R^{30} preferably represents an alkoxy group as one solution strategy. In another solution strategy, multiple types of R^{21} to R^{30} are preferably used together. For example, each of R^{21} to R^{30} is preferably a combination of compounds having alkyl groups or alkenyl groups having 2, 3, and 4 carbon atoms, a combination of compounds having alkyl groups or alkenyl groups having 3 and 5 carbon atoms, or a combination of compounds having alkyl groups or alkenyl groups having 3, 4, and 5 carbon atoms.

[0038] R^{21} and R^{22} preferably represent an alkyl group or an alkenyl group and at least one of R^{21} and R^{22} preferably represents an alkenyl group. A compound in which both R^{21} and R^{22} are alkenyl groups is suitably used to improve the response speed, but is not preferred in the case where the chemical stability of a liquid crystal display element is improved. At least one of R^{23} and R^{24} preferably represents an alkyl group, an alkoxy group, or an alkenyl group having 4 or 5 carbon atoms. To achieve good balance between response speed and T_{ni} , at least one of R^{23} and R^{24} preferably represents an alkenyl group. To achieve good balance between response speed and solubility at low temperature, at

least one of R²³ and R²⁴ preferably represents an alkoxy group.

[0039] At least one of R²⁵ and R²⁶ preferably represents an alkyl group, an alkoxy group, or an alkenyl group having 2 to 5 carbon atoms. To achieve good balance between response speed and T_{ni}, at least one of R²⁵ and R²⁶ preferably represents an alkenyl group. To achieve good balance between response speed and solubility at low temperature, at least one of R²⁵ and R²⁶ preferably represent an alkoxy group. More preferably, R²⁵ represents an alkenyl group and R²⁶ represents an alkyl group. It is also preferred that R²⁵ represent an alkyl group and R²⁶ represent an alkoxy group.

[0040] At least one of R²⁷ and R²⁸ preferably represents an alkyl group, an alkoxy group, or an alkenyl group having 2 to 5 carbon atoms. To achieve good balance between response speed and T_{ni}, at least one of R²⁷ and R²⁸ preferably represents an alkenyl group. To achieve good balance between response speed and solubility at low temperature, at least one of R²⁷ and R²⁸ preferably represents an alkoxy group. More preferably, R²⁷ represents an alkyl group or an alkenyl group and R²⁸ represents an alkyl group. It is also preferred that R²⁷ represent an alkyl group and R²⁸ represent an alkoxy group. Furthermore, it is particularly preferred that R²⁷ represent an alkyl group and R²⁸ represent an alkyl group.

[0041] X²¹ is preferably a fluorine atom.

[0042] One to ten of the compounds represented by general formula (II-a) to general formula (II-e) are preferably contained and one to eight of the compounds are particularly preferably contained. The content of the compounds is preferably 5% to 80% by mass, more preferably 10% to 70% by mass, and particularly preferably 20% to 60% by mass.

[0043] The liquid crystal composition layer in the liquid crystal display device of the present invention may further contain at least one compound selected from the group consisting of compounds represented by general formula (III-a) to general formula (III-f).

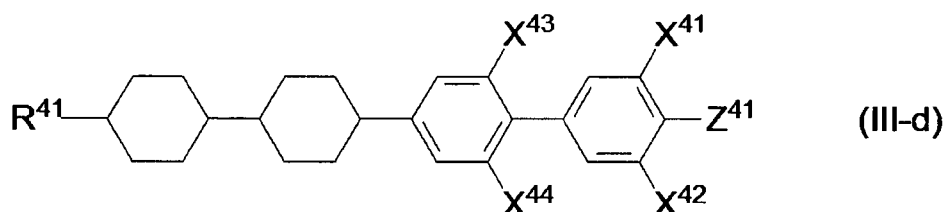
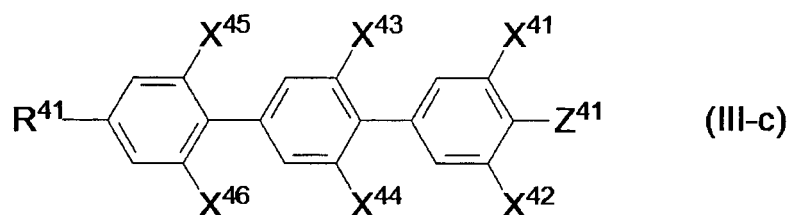
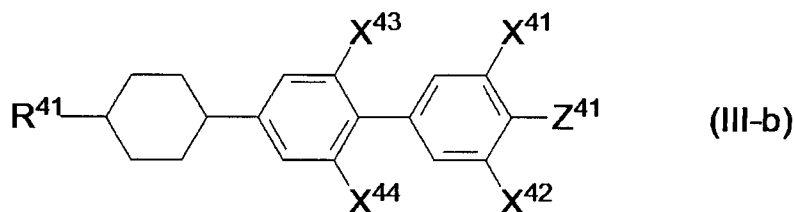
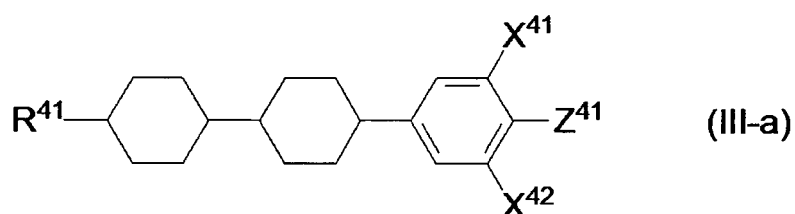

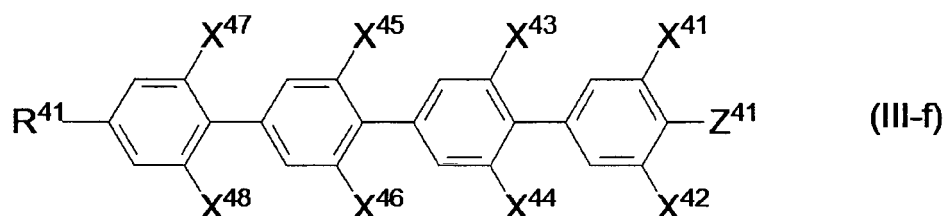
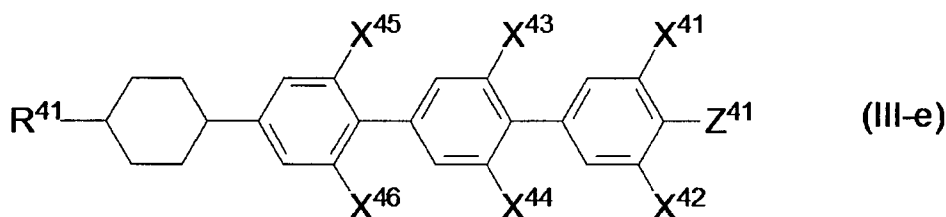

[0044] In general formulae, R^{41} represents an alkyl group or alkoxy group having 1 to 10 carbon atoms or an alkenyl group or alkenyloxy group having 2 to 10 carbon atoms, X^{41} to X^{48} each independently represent a hydrogen atom or a fluorine atom, and Z^{41} represents a fluorine atom, a trifluoromethoxy group, or a trifluoromethyl group.

[0045] In general formula (IIIa) to general formula (III-f), when the ring structure to which R^{41} bonds is a phenyl group (aromatic group), R^{41} preferably represents a linear alkyl group having 1 to 5 carbon atoms, a linear alkoxy group having 1 to 4 (or more) carbon atoms, or an alkenyl group having 4 or 5 carbon atoms. When the ring structure to which R^{41} bonds is a saturated ring structure such as cyclohexane, pyran, or dioxane, R^{41} preferably represents a linear alkyl group having 1 to 5 carbon atoms, a linear alkoxy group having 1 to 4 (or more) carbon atoms, or a linear alkenyl group having 2 to 5 carbon atoms.

[0046] When an importance is given to good chemical stability to heat and light, R^{41} preferably represents an alkyl group. When an importance is given to production of a liquid crystal display element having high response speed due to low viscosity, R^{41} preferably represents an alkenyl group. Furthermore, for the purpose of decreasing the viscosity, increasing the nematic-isotropic phase transition temperature (T_{ni}), and further improving the response speed, an alkenyl group whose terminal bond is not an unsaturated bond is preferably used and an alkenyl group having a methyl group bonded to the terminal of the alkenyl group is particularly preferably used. When an importance is given to high solubility at low temperature, R^{41} preferably represents an alkoxy group as one solution strategy. In another solution strategy, multiple types of R^{41} are preferably used together. For example, R^{41} is preferably a combination of compounds having alkyl groups or alkenyl groups having 2, 3, and 4 carbon atoms, a combination of compounds having alkyl groups or alkenyl groups having 3 and 5 carbon atoms, or a combination of compounds having alkyl groups or alkenyl groups having 3, 4, and 5 carbon atoms.

[0047] At least one of X^{41} and X^{42} preferably represents a fluorine atom and both of X^{41} and X^{42} more preferably represent fluorine atoms.

[0048] Z^{41} preferably represents a fluorine atom or a trifluoromethoxy group.

[0049] Regarding the combination of X^{41} , X^{42} , and Z^{41} , in one embodiment, $X^{41} = F$, $X^{42} = F$, and $Z^{41} = F$. In another embodiment, $X^{41} = F$, $X^{42} = H$, and $Z^{41} = F$. In still another embodiment, $X^{41} = F$, $X^{42} = H$, and $Z^{41} = OCF_3$. In still another embodiment, $X^{41} = F$, $X^{42} = F$, and $Z^{41} = OCF_3$. In still another embodiment, $X^{41} = H$, $X^{42} = H$, and $Z^{41} = OCF_3$.

[0050] At least one of X^{43} and X^{44} preferably represents a fluorine atom and both of X^{43} and X^{44} preferably represent fluorine atoms to increase $\Delta\epsilon$. However, it is not preferred that both of X^{43} and X^{44} represent fluorine atoms in terms of improvement in solubility at low temperature.

[0051] At least one of X^{45} and X^{46} preferably represents a hydrogen atom and both of X^{45} and X^{46} more preferably represent hydrogen atoms. The use of fluorine atoms in a large amount is not preferred in view of T_{ni} , solubility at low temperature, and chemical stability in the form of a liquid crystal display element.

[0052] At least one of X^{47} and X^{48} preferably represents a hydrogen atom and both of X^{47} and X^{48} more preferably represent hydrogen atoms. It is not preferred that at least one of X^{47} and X^{48} represent a fluorine atom in view of T_{ni} , solubility at low temperature, and chemical stability in the form of a liquid crystal display element.

[0053] One to ten of the compounds selected from the group consisting of the compounds represented by general formula (III-a) to general formula (III-f) are preferably contained and one to eight of the compounds are more preferably contained. The content of the compounds is preferably 5% to 50% by mass and more preferably 10% to 40% by mass.

[0054] In the liquid crystal composition of the liquid crystal composition layer in the liquid crystal display device of the present invention, $\Delta\epsilon$ at 25°C is preferably +3.5 or more and more preferably +3.5 to +15.0. Furthermore, Δn at 25°C is preferably 0.08 to 0.14 and more preferably 0.09 to 0.13. More specifically, Δn is preferably 0.10 to 0.13 when a small cell gap is employed and 0.08 to 0.10 when a large cell gap is employed. Moreover, η at 20°C is preferably 10 to 45

EP 2 796 922 B1

mPa·s, more preferably 10 to 25 mPa·s, and particularly preferably 10 to 20 mPa·s. T_{ni} is preferably 60°C to 120°C, more preferably 70°C to 100°C, and particularly preferably 70°C to 85°C.

[0055] In addition to the above compounds, the liquid crystal composition in the present invention may contain typical nematic liquid crystal, smectic liquid crystal, and cholesteric liquid crystal.

[0056] The liquid crystal composition in the present invention may contain at least one polymerizable compound for the purpose of producing a liquid crystal display element with, for example, a PS mode, a transverse electric field-type PSA mode, or a transverse electric field-type PSVA mode. For example, a photopolymerizable monomer whose polymerization proceeds with energy rays such as light can be used as the polymerizable compound. In terms of structure, a polymerizable compound having a liquid crystal skeleton formed by bonding a plurality of six-membered rings, such as a biphenyl derivative or a terphenyl derivative is exemplified. More specifically, the polymerizable compound is preferably a bifunctional monomer represented by general formula (V).

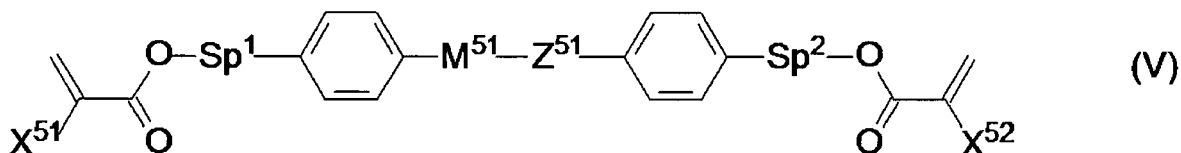

[0057] In general formula, X^{51} and X^{52} each independently represent a hydrogen atom or a methyl group and Sp^1 and Sp^2 each independently represent a single bond, an alkylene group having 1 to 8 carbon atoms, or $-O-(CH_2)_s-$ (where s represents an integer of 2 to 7 and the oxygen atom bonds to an aromatic ring); Z^{51} represents $-OCH_2-$, $-CH_2O-$, $-COO-$, $-OCO-$, $-CF_2O-$, $-OCF_2-$, $-CH_2CH_2-$, $-CF_2CF_2-$, $-CH=CH-COO-$, $-CH=CH-OCO-$, $-COO-CH=CH-$, $-OCO-CH=CH-$, $-COO-CH_2CH_2-$, $-OCO-CH_2CH_2-$, $-CH_2CH_2-COO-$, $-CH_2CH_2-OCO-$, $-COO-CH_2-$, $-OCO-CH_2-$, $-CH_2-COO-$, $-CH_2-OCO-$, $-CY^1=CY^2-$ (where Y^1 and Y^2 each independently represent a fluorine atom or a hydrogen atom), $-C\equiv C-$, or a single bond; and

M^{51} represents a 1,4-phenylene group, a trans-1,4-cyclohexylene group, or a single bond and, in all the 1,4-phenylene groups in general formula, any of hydrogen atoms may be substituted with fluorine atoms.

[0058] The polymerizable compound is preferably any of a diacrylate derivative in which X^{51} and X^{52} each represent a hydrogen atom and a dimethacrylate derivative in which X^{51} and X^{52} each represent a methyl group, and is also preferably a compound in which one of X^{51} and X^{52} represents a hydrogen atom and the other represents a methyl group. Among these compounds, the diacrylate derivative has the highest rate of polymerization, the dimethacrylate derivative has a low rate of polymerization, and the asymmetrical compound has an intermediate rate of polymerization. A preferred one can be used in accordance with the applications. In a PSA display element, the dimethacrylate derivative is particularly preferably used.

[0059] Sp^1 and Sp^2 each independently represent a single bond, an alkylene group having 1 to 8 carbon atoms, or $-O-(CH_2)_s-$. In a PSA display element, at least one of Sp^1 and Sp^2 preferably represents a single bond. A compound in which Sp^1 and Sp^2 each represent a single bond or a compound in which one of Sp^1 and Sp^2 represents a single bond and the other represents an alkylene group having 1 to 8 carbon atoms or $-O-(CH_2)_s-$ is preferred. In this case, an alkyl group having 1 to 4 carbon atoms is preferred and s is preferably 1 to 4.

[0060] Z^{51} preferably represents $-OCH_2-$, $-CH_2O-$, $-COO-$, $-OCO-$, $-CF_2O-$, $-OCF_2-$, $-CH_2CH_2-$, $-CF_2CF_2-$, or a single bond, more preferably $-COO-$, $-OCO-$, or a single bond, and particularly preferably a single bond.

[0061] M^{51} represents a 1,4-phenylene group in which any of hydrogen atoms may be substituted with fluorine atoms, a trans-1,4-cyclohexylene group, or a single bond and preferably represents the 1,4-phenylene group or a single bond. When M^{51} represents a ring structure other than a single bond, Z^{51} preferably represents a linking group other than a single bond. When M^{51} represents a single bond, Z^{51} preferably represents a single bond.

[0062] In view of the foregoing, the ring structure between Sp^1 and Sp^2 in general formula (V) is preferably the following structure.

[0063] In the case where M^{51} represents a single bond and the ring structure is constituted by two rings in general formula (V), the ring structure is preferably represented by formula (Va-1) to formula (Va-5) below, more preferably represented by formula (Va-1) to formula (Va-3), and particularly preferably represented by formula (Va-1).

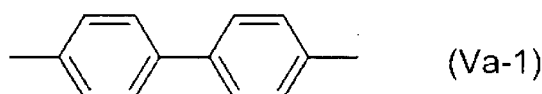

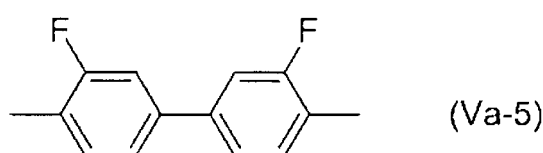
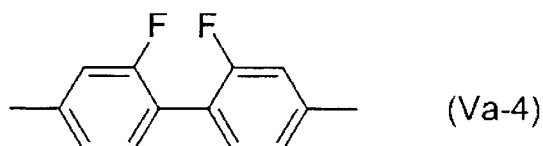
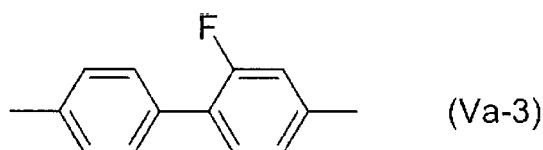
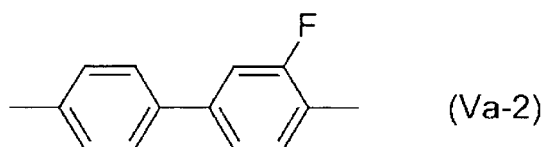

25 **[0064]** In formulae, both ends bond to Sp^1 and Sp^2 .

[0065] The anchoring strength after the polymerization of the polymerizable compound having such a skeleton is suitable for PSA-type liquid crystal display elements, and a good alignment state is achieved. Therefore, the display unevenness is suppressed or completely prevented.

30 **[0066]** Accordingly, the polymerizable compound is particularly preferably represented by general formula (V-1) to general formula (V-4) and most preferably represented by general formula (V-2).

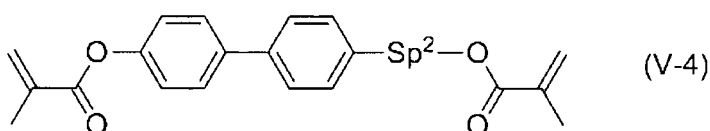
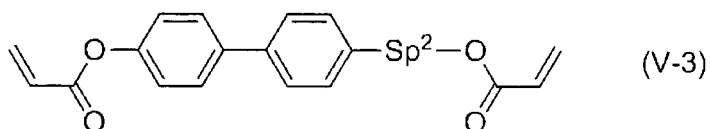
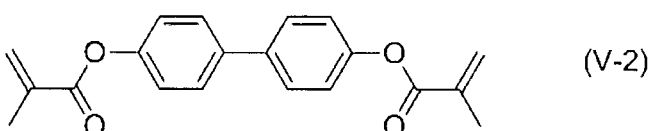
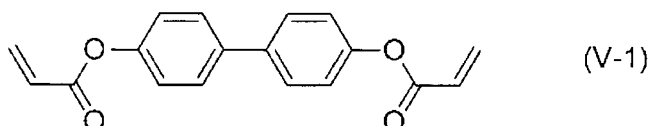

55

[0067] In general formulae, Sp^2 represents an alkylene group having 2 to 5 carbon atoms.

[0068] In the case where the polymerizable compound is added to the liquid crystal composition of the present invention, polymerization proceeds without a polymerization initiator, but a polymerization initiator may be contained to facilitate

the polymerization. Examples of the polymerization initiator include benzoin ethers, benzophenones, acetophenones, benzylketals, and acylphosphine oxides.

[0069] The liquid crystal composition containing the polymerizable compound in the present invention is provided with liquid crystal alignment capability by polymerizing the polymerizable compound through irradiation with ultraviolet rays and is used for liquid crystal display elements that control the amount of transmitted light by using the birefringence of the liquid crystal composition. The liquid crystal composition is useful for liquid crystal display elements such as an AM-LCD (active matrix liquid crystal display element), a TN (twisted nematic liquid crystal display element), an STN-LCD (super-twisted nematic liquid crystal display element), an OCB-LCD, and an IPS-LCD (in-plane switching liquid crystal display element). The liquid crystal composition is particularly useful for AM-LCDs and can be used for transmission or reflection-type liquid crystal display elements.

(Color filter)

[0070] A color filter of the present invention is constituted by a black matrix and at least RGB three color pixel portions. The RGB three color pixel portions contain, in a G pixel portion as a coloring material, a halogenated metal phthalocyanine pigment having a central metal selected from the group consisting of Al, Si, Sc, Ti, V, Mg, Fe, Co, Ni, Zn, Ga, Ge, Y, Zr, Nb, In, Sn, and Pb. When the central metal is a trivalent metal, any one of a halogen atom, a hydroxyl group, and a sulfonic acid group bonds to the central metal or the central metal forms an oxo-bridge or thio-bridge. When the central metal is a tetravalent metal, a single oxygen atom or any two of a halogen atom, a hydroxyl group, and a sulfonic acid group which may be the same or different bond to the central metal. The RGB three color pixel portions also preferably contain, as coloring materials, a diketopyrrolopyrrole pigment and/or an anionic red organic dye in an R pixel portion and an ϵ -type copper phthalocyanine pigment and/or a cationic blue organic dye in a B pixel portion.

(G pixel portion)

[0071] The above halogenated metal phthalocyanine pigment in the G pixel portion may be halogenated metal phthalocyanine pigments that belong to the following two groups.

(First group)

[0072] The halogenated metal phthalocyanine pigment is a halogenated metal phthalocyanine pigment having a central metal selected from the group consisting of Al, Si, Sc, Ti, V, Mg, Fe, Co, Ni, Zn, Ga, Ge, Y, Zr, Nb, In, Sn, and Pb and having a structure in which 8 to 16 halogen atoms per molecule of phthalocyanine bond to benzene rings of a phthalocyanine molecule. When the central metal is a trivalent metal, any one of a halogen atom, a hydroxyl group, and a sulfonic acid group ($-\text{SO}_3\text{H}$) bonds to the central metal. When the central metal is a tetravalent metal, a single oxygen atom or any two of a halogen atom, a hydroxyl group, and a sulfonic acid group which may be the same or different bond to the central metal.

(Second group)

[0073] The halogenated metal phthalocyanine pigment is a pigment composed of a halogenated metal phthalocyanine dimer including, as constitutional units, two molecules of a halogenated metal phthalocyanine having a trivalent central metal selected from the group consisting of Al, Sc, Ga, Y and In and having a structure in which 8 to 16 halogen atoms per molecule of phthalocyanine bond to benzene rings of a phthalocyanine molecule. In the halogenated metal phthalocyanine dimer, the central metals of the constitutional units are bonded to each other through a divalent atomic group selected from the group consisting of an oxygen atom, a sulfur atom, sulfinyl ($-\text{SO}-$), and sulfonyl ($-\text{SO}_2-$).

[0074] In the halogenated metal phthalocyanine pigment used in the present invention, all the halogen atoms that bond to the benzene rings may be the same or different from each other. Different halogen atoms may bond to a single benzene ring.

[0075] A halogenated metal phthalocyanine pigment used in the present invention in which 9 to 15 bromine atoms among 8 to 16 halogen atoms per molecule of phthalocyanine bond to benzene rings of a phthalocyanine molecule shows yellowish bright green and is suitably used in a green pixel portion of a color filter. The halogenated metal phthalocyanine pigment used in the present invention is insoluble or sparingly soluble in water or an organic solvent. The halogenated metal phthalocyanine pigment used in the present invention may be a pigment (also referred to as a "crude pigment") not subjected to a finishing treatment described below or a pigment subjected to a finishing treatment.

[0076] The halogenated metal phthalocyanine pigments that belong to the first group and the second group can be represented by general formula (PIG-1) below.

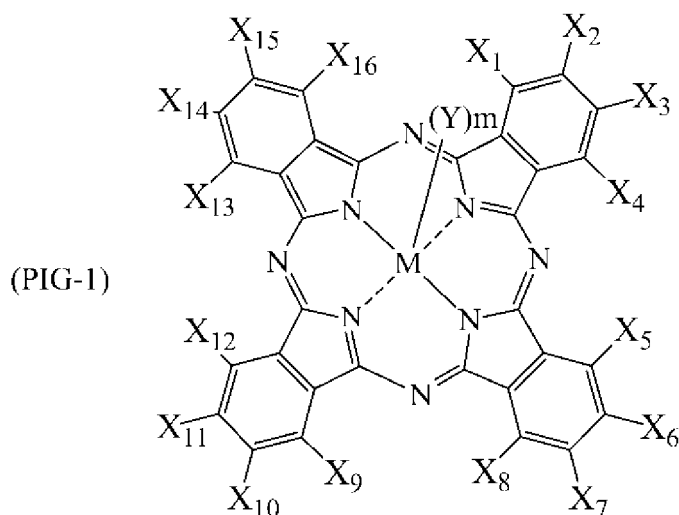

20 **[0077]** In general formula (PIG-1), the halogenated metal phthalocyanine pigment that belongs to the first group is as follows.

25 **[0078]** In general formula (PIG-1), X_1 to X_{16} each represent a hydrogen atom, a chlorine atom, a bromine atom, or an iodine atom. Four X atoms that bond to a single benzene ring may be the same or different. Among X_1 to X_{16} that bond to four benzene rings, 8 to 16 of them are chlorine atoms, bromine atoms, or iodine atoms. M represents a central metal. When halogenated metal phthalocyanine pigments have the same Y, which will be described below, and the same number m of Y, pigments having chlorine atoms, bromine atoms, and iodine atoms in a total number of less than 8 among 16 atoms of X_1 to X_{16} show blue, and pigments having chlorine atoms, bromine atoms, and iodine atoms in a total number of 8 or more among 16 atoms of X_1 to X_{16} become more yellowish as the total number increases. Y that bonds to the central metal M is a monovalent atomic group selected from the group consisting of a halogen atom such as fluorine, chlorine, bromine, or iodine, an oxygen atom, a hydroxyl group, and a sulfonic acid group; and m represents the number of Y that bonds to the central metal M, m being an integer of 0 to 2.

35 **[0079]** The value of m is determined on the basis of the valence of the central metal M. When the central metal M is a trivalent metal such as Al, Sc, Ga, Y, or In, $m = 1$ and one of groups selected from the group consisting of fluorine, chlorine, bromine, iodine, a hydroxyl group, or a sulfonic acid group bonds to the central metal. When the central metal M is a tetravalent metal such as Si, Ti, V, Ge, Zr, or Sn, $m = 2$ and a single oxygen atom bonds to the central metal or two of groups selected from the group consisting of fluorine, chlorine, bromine, iodine, a hydroxyl group, and a sulfonic acid group bond to the central metal. If the central metal M is a divalent metal such as Mg, Fe, Co, Ni, Zn, Zr, Sn, or Pb, Y is not present.

40 **[0080]** In above general formula (PIG-1), the halogenated metal phthalocyanine pigment that belongs to the second group is as follows.

[0081] In above general formula (PIG-1), X_1 to X_{16} have the same definition as above; the central metal M represents a trivalent metal selected from the group consisting of Al, Sc, Ga, Y, and In; m represents 1; and Y represents the following atomic group.

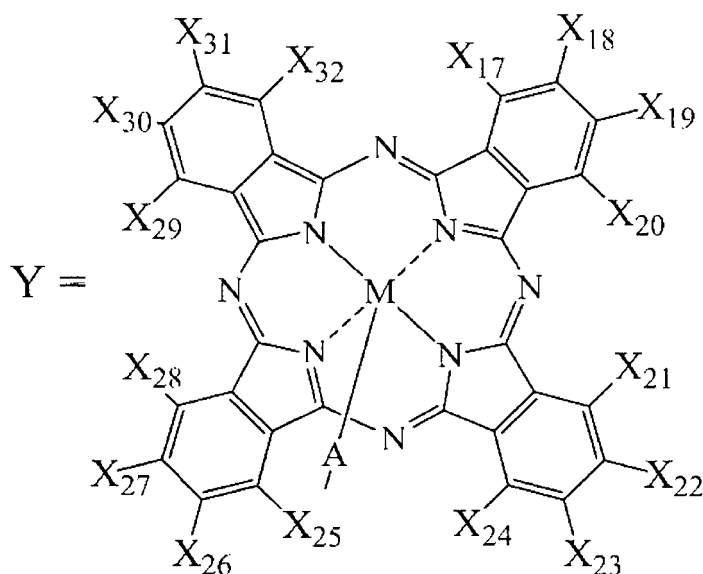

[0082] In the chemical structure of the atomic group Y, the central metal M has the same definition as above and X₁₇ to X₃₂ have the same definition as that of X₁ to X₁₆ in general formula (PIG-1). A represents a divalent atomic group selected from the group consisting of an oxygen atom, a sulfur atom, sulfinyl (-SO-), and sulfonyl (-SO₂-). M in general formula (PIG-1) and M in the atomic group Y are bonded to each other through the divalent atomic group A.

[0083] In other words, the halogenated metal phthalocyanine pigment that belongs to the second group is composed of a halogenated metal phthalocyanine dimer including, as constitutional units, two molecules of a halogenated metal phthalocyanine, the two molecules being bonded to each other through the divalent atomic group.

[0084] Specific examples of the halogenated metal phthalocyanine pigment represented by general formula (PIG-1) include pigments (1) to (4) below:

(1) a halogenated metal phthalocyanine pigment such as a halogenated tin phthalocyanine pigment, a halogenated nickel phthalocyanine pigment, or a halogenated zinc phthalocyanine pigment, in which the central metal is a divalent metal selected from the group consisting of Mg, Fe, Co, Ni, Zn, Zr, Sn, and Pb and 8 to 16 halogen atoms per molecule of phthalocyanine bond to four benzene rings (note that, among the phthalocyanine pigments, a chlorinated/brominated zinc phthalocyanine pigment such as C.I. Pigment Green 58 is particularly preferred);

(2) a halogenated metal phthalocyanine pigment such as a halogenated chloroaluminum phthalocyanine, in which the central metal is a trivalent metal selected from the group consisting of Al, Sc, Ga, Y, and In, any one of a halogen atom, a hydroxyl group, and a sulfonic acid group bonds to the central metal, and 8 to 16 halogen atoms per molecule of phthalocyanine bond to four benzene rings;

(3) a halogenated metal phthalocyanine pigment such as a halogenated oxytitanium phthalocyanine or a halogenated oxyvanadium phthalocyanine, in which the central metal is a tetravalent metal selected from the group consisting of Si, Ti, V, Ge, Zr, and Sn, a single oxygen atom or any two of a halogen atom, a hydroxyl group, and a sulfonic acid group which may be the same or different bond to the central metal, and 8 to 16 halogen atoms per molecule of phthalocyanine bond to four benzene rings; and

(4) a pigment composed of a halogenated metal phthalocyanine dimer, such as a halogenated μ -oxo-aluminum phthalocyanine dimer or a halogenated μ -thio-aluminum phthalocyanine dimer, that includes, as constitutional units, two molecules of a halogenated metal phthalocyanine having a trivalent central metal selected from the group consisting of Al, Sc, Ga, Y and In and having a structure in which 8 to 16 halogen atoms per molecule of phthalocyanine bond to four benzene rings, the central metals of the constitutional units being bonded to each other through a divalent atomic group selected from the group consisting of an oxygen atom, a sulfur atom, sulfinyl, and sulfonyl.

(R pixel portion)

[0085] The R pixel portion preferably contains a diketopyrrolopyrrole pigment and/or an anionic red organic dye. Specifically, the diketopyrrolopyrrole pigment is preferably C.I. Pigment Red 254, 255, 264, or 272 or C.I. Pigment Orange 71 or 73, more preferably Red 254, 255, 264, or 272, and particularly preferably C.I. Pigment Red 254. The anionic red organic dye is preferably C.I. Solvent Red 124 or Acid Red 52 or 289 and particularly preferably C.I. Solvent Red 124.

(B pixel portion)

[0086] The B pixel portion preferably contains an ϵ -type copper phthalocyanine pigment and/or a cationic blue organic dye. The ϵ -type copper phthalocyanine pigment is C.I. Pigment Blue 15:6. The cationic blue organic dye is preferably C.I. Solvent Blue 2, 3, 4, 5, 6, 7, 23, 43, 72, or 124 or C.I. Basic Blue 7 or 26, more preferably C.I. Solvent Blue 7 or C.I. Basic Blue 7, and particularly preferably C.I. Solvent Blue 7.

[0087] The RGB three color pixel portions preferably contain, as coloring materials, C.I. Solvent Red 124 in the R pixel portion, a halogenated metal phthalocyanine pigment in the G pixel portion, and C.I. Solvent Blue 7 in the B pixel portion. Herein, the halogenated metal phthalocyanine pigment has a central metal selected from the group consisting of Al, Si, Sc, Ti, V, Mg, Fe, Co, Ni, Zn, Ga, Ge, Y, Zr, Nb, In, Sn, and Pb; when the central metal is a trivalent metal, any one of a halogen atom, a hydroxyl group, and a sulfonic acid group bonds to the central metal or the central metal forms an oxo-bridge or thio-bridge; and, when the central metal is a tetravalent metal, a single oxygen atom or any two of a halogen atom, a hydroxyl group, and a sulfonic acid group which may be the same or different bond to the central metal or the central metal forms an oxo-bridge or thio-bridge.

[0088] The RGB three color pixel portions also preferably contain, as coloring materials, C.I. Pigment Red 254 in the R pixel portion, a halogenated metal phthalocyanine pigment in the G pixel portion, and C.I. Pigment Blue 15:6 in the B pixel portion. Herein, the halogenated metal phthalocyanine pigment has a central metal selected from the group consisting of Al, Si, Sc, Ti, V, Mg, Fe, Co, Ni, Zn, Ga, Ge, Y, Zr, Nb, In, Sn, and Pb; when the central metal is a trivalent metal, any one of a halogen atom, a hydroxyl group, and a sulfonic acid group bonds to the central metal or the central metal forms an oxo-bridge or thio-bridge; and, when the central metal is a tetravalent metal, a single oxygen atom or any two of a halogen atom, a hydroxyl group, and a sulfonic acid group which may be the same or different bond to the central metal.

[0089] The RGB three color pixel portions preferably further contain, as a coloring material, at least one organic dye or pigment selected from the group consisting of C.I. Pigment Red 177, 242, 166, 167, and 179, C.I. Pigment Orange 38 and 71, C.I. Pigment Yellow 150, 215, 185, 138, and 139, C.I. Solvent Red 89, C.I. Solvent Orange 56, and C.I. Solvent Yellow 21, 82, 83:1, 33, and 162 in the R pixel portion.

[0090] The RGB three color pixel portions preferably further contain, as a coloring material, at least one organic dye or pigment selected from the group consisting of C.I. Pigment Yellow 150, 215, 185, and 138 and C.I. Solvent Yellow 21, 82, 83:1, and 33 in the G pixel portion.

[0091] The RGB three color pixel portions preferably further contain, as a coloring material, at least one organic dye or pigment selected from the group consisting of C.I. Pigment Blue 1, C.I. Pigment Violet 23, C.I. Basic Blue 7, C.I. Basic Violet 10, C.I. Acid Blue 1, 90, and 83, and C.I. Direct Blue 86 in the B pixel portion.

[0092] Preferably, the color filter is constituted by a black matrix, the RGB three color pixel portions, and a Y pixel portion, and the Y pixel portion contains, as a coloring material, at least one yellow organic dye or pigment selected from the group consisting of C.I. Pigment Yellow 150, 215, 185, 138, and 139 and C.I. Solvent Yellow 21, 82, 83:1, 33, and 162.

[0093] In the color filter according to the present invention, the chromaticity x and chromaticity y in the XYZ color system of each pixel portion with use of a C light source are preferably as follows from the viewpoint of preventing a decrease in the voltage holding ratio (VHR) of the liquid crystal layer and an increase in the ion density (ID) and suppressing problems of display defects such as white streaks, alignment unevenness, and image sticking.

[0094] The chromaticity x in the XYZ color system of the R pixel portion with use of a C light source is preferably 0.58 to 0.69 and more preferably 0.62 to 0.68 and the chromaticity y is preferably 0.30 to 0.36 and more preferably 0.31 to 0.35. Preferably, the chromaticity x is 0.58 to 0.69 and the chromaticity y is 0.30 to 0.36. More preferably, the chromaticity x is 0.62 to 0.68 and the chromaticity y is 0.31 to 0.35.

[0095] The chromaticity x in the XYZ color system of the G pixel portion with use of a C light source is preferably 0.19 to 0.32 and more preferably 0.20 to 0.26 and the chromaticity y is preferably 0.60 to 0.76 and more preferably 0.68 to 0.74. Preferably, the chromaticity x is 0.19 to 0.32 and the chromaticity y is 0.60 to 0.76. More preferably, the chromaticity x is 0.20 to 0.26 and the chromaticity y is 0.68 to 0.74.

[0096] The chromaticity x in the XYZ color system of the B pixel portion with use of a C light source is preferably 0.11 to 0.16 and more preferably 0.12 to 0.15 and the chromaticity y is preferably 0.04 to 0.15 and more preferably 0.05 to 0.10. Preferably, the chromaticity x is 0.11 to 0.16 and the chromaticity y is 0.04 to 0.15. More preferably, the chromaticity x is 0.12 to 0.15 and the chromaticity y is 0.05 to 0.10.

[0097] The chromaticity x in the XYZ color system of the Y pixel portion with use of a C light source is preferably 0.46 to 0.50 and more preferably 0.47 to 0.48 and the chromaticity y is preferably 0.48 to 0.53 and more preferably 0.50 to 0.52. Preferably, the chromaticity x is 0.46 to 0.50 and the chromaticity y is 0.48 to 0.53. More preferably, the chromaticity x is 0.47 to 0.48 and the chromaticity y is 0.50 to 0.52.

[0098] Herein, the XYZ color system is a color system approved as the standard color system by the CIE (International Commission on Illumination) in 1931.

[0099] The chromaticity in each pixel portion can be adjusted by changing the types of dyes and pigments used and

the mixing ratio of the dyes and pigments. For example, in the case of the R pixel, the chromaticity can be adjusted by adding an appropriate amount of a yellow dye/pigment and/or an orange pigment to the red dye/pigment. In the case of the G pixel, the chromaticity can be adjusted by adding an appropriate amount of a yellow dye/pigment to the green dye/pigment. In the case of the B pixel, the chromaticity can be adjusted by adding an appropriate amount of a purple dye/pigment to the blue dye/pigment. The chromaticity can also be adjusted by appropriately controlling the particle size of a pigment.

[0100] In the color filter, color filter pixel portions can be formed by a publicly known method. A typical example of a method for forming pixel portions is a photolithography method. In the photolithography method, a photo-curable composition described below is applied onto a surface of a transparent substrate for color filters on the black matrix side and dried by performing heating (pre-baked); pattern exposure is then performed by irradiating the photo-curable composition with ultraviolet rays through a photomask to cure the photo-curable compound in portions corresponding to pixel portions; and unexposed portions are developed with a developer to remove portions other than the pixel portions, whereby the pixel portions are fixed on the transparent substrate. In this method, pixel portions composed of a cured colored coating film of the photo-curable composition are formed on the transparent substrate.

[0101] The photo-curable composition described below is prepared for each of the R pixel, G pixel, B pixel, and optionally other pixels of different colors, such as the Y pixel and the above-described process is repeatedly performed. Thus, a color filter including colored pixel portions of the R pixel, G pixel, B pixel, and Y pixel in predetermined positions can be produced.

[0102] Examples of a method for applying the photo-curable composition described below onto the transparent substrate composed of glass or the like include a spin coating method, a slit coating method, a roll coating method, and an ink-jet method.

[0103] The drying conditions of the coating film of the photo-curable composition applied onto the transparent substrate are normally 50°C to 150°C and about 1 to 15 minutes though depending on, for example, the types of components and the mixing ratio. The light used for the photo-curing of the photo-curable composition is preferably ultraviolet light or visible light in a wavelength range of 200 to 500 nm. Various light sources that emit light in this wavelength range can be used.

[0104] Examples of a developing method include a puddling method, a dipping method, and a spraying method. After the exposure and development of the photo-curable composition, the transparent substrate on which pixel portions of necessary colors have been formed is washed with water and dried. The thus-produced color filter is heat-treated (post-baked) at 90°C to 280°C for a predetermined time using a heating device such as a hot plate, an oven, or the like to remove volatile components in the colored coating film and, at the same time, heat-cure an unreacted photo-curable compound remaining in the cured colored coating film of the photo-curable composition, whereby the color filter is completed.

[0105] By using the coloring material for color filters of the present invention together with the liquid crystal composition of the present invention, there can be provided a liquid crystal display device in which a decrease in the voltage holding ratio (VHR) of a liquid crystal layer and an increase in the ion density (ID) are prevented and problems of display defects such as white streaks, alignment unevenness, and image sticking are overcome.

[0106] The photo-curable composition is generally produced by the method below. The dye and/or pigment composition for color filters of the present invention, an organic solvent, and a dispersant serving as essential components are stirred and dispersed so as to be uniformly mixed with each other in order to prepare a pigment dispersion liquid for forming pixel portions of a color filter. A photo-curable compound and optionally a thermoplastic resin, a photopolymerization initiator, and the like are added to the pigment dispersion liquid to produce the photo-curable composition.

[0107] Examples of the organic solvent used herein include aromatic solvents such as toluene, xylene, and methoxybenzene; acetate solvents such as ethyl acetate, propyl acetate, butyl acetate, propylene glycol monomethyl ether acetate, propylene glycol monoethyl ether acetate, diethylene glycol methyl ether acetate, diethylene glycol ethyl ether acetate, diethylene glycol propyl ether acetate, and diethylene glycol butyl ether acetate; propionate solvents such as ethoxyethyl propionate; alcohol solvents such as methanol and ethanol; ether solvents such as butyl cellosolve, propylene glycol monomethyl ether, diethylene glycol ethyl ether, and diethylene glycol dimethyl ether; ketone solvents such as methyl ethyl ketone, methyl isobutyl ketone, and cyclohexanone; aliphatic hydrocarbon solvents such as hexane; nitrogen compound solvents such as N,N-dimethyl formamide, γ -butyrolactam, N-methyl-2-pyrrolidone, aniline, and pyridine; lactone solvents such as γ -butyrolactone; and carbamates such as a mixture containing methyl carbamate and ethyl carbamate at a ratio of 48:52.

[0108] Examples of the dispersant used herein include DISPERBYK 130, DISPERBYK 161, DISPERBYK 162, DISPERBYK 163, DISPERBYK 170, DISPERBYK 171, DISPERBYK 174, DISPERBYK 180, DISPERBYK 182, DISPERBYK 183, DISPERBYK 184, DISPERBYK 185, DISPERBYK 2000, DISPERBYK 2001, DISPERBYK 2020, DISPERBYK 2050, DISPERBYK 2070, DISPERBYK 2096, DISPERBYK 2150, DISPERBYK LPN21116, and DISPERBYK LPN6919 manufactured by BYK-Chemie GmbH; Efka 46, Efka 47, Efka 452, Efka LP4008, Efka 4009, Efka LP4010, Efka LP4050, LP4055, Efka 400, Efka 401, Efka 402, Efka 403, Efka 450, Efka 451, Efka 453, Efka 4540, Efka 4550, Efka LP4560,

Efka 120, Efka 150, Efka 1501, Efka 1502, and Efka 1503 manufactured by Efka Chemicals Company; Solsperse 3000, Solsperse 9000, Solsperse 13240, Solsperse 13650, Solsperse 13940, Solsperse 17000, 18000, Solsperse 20000, Solsperse 21000, Solsperse 20000, Solsperse 24000, Solsperse 26000, Solsperse 27000, Solsperse 28000, Solsperse 32000, Solsperse 36000, Solsperse 37000, Solsperse 38000, Solsperse 41000, Solsperse 42000, Solsperse 43000, Solsperse 46000, Solsperse 54000, and Solsperse 71000 manufactured by Lubrizol Corporation; Ajisper PB711, Ajisper PB821, Ajisper PB822, Ajisper PB814, Ajisper PN411, and Ajisper PA111 manufactured by Ajinomoto Co., Ltd.; and synthetic resins which are liquid and water-insoluble at room temperature, e.g., acrylic resins, urethane resins, alkyd resins, natural rosins such as wood rosin, gum rosin, and tall oil rosin, modified rosins such as polymerized rosin, disproportionated rosin, hydrogenated rosin, oxidized rosin, and maleated rosin, and rosin derivatives such as rosin amine, lime rosin, rosin alkylene oxide adducts, rosin alkyd adducts, and rosin-modified phenol. The addition of these dispersants and resins contributes to a reduction in flocculation, an improvement in the dispersion stability of pigments, and an improvement in the viscous property of dispersions.

[0109] Examples of a dispersing aid include organic pigment derivatives such as phthalimidemethyl derivatives, sulfonic acid derivatives, N-(dialkylamino)methyl derivatives, and N-(dialkylaminoalkyl)sulfonic acid amide derivatives. Two or more different types of these derivatives can be used in combination.

[0110] Examples of the thermoplastic resin used to prepare the photo-curable composition include urethane resins, acrylic resins, polyamide resins, polyimide resins, styrene-maleic acid resins, and styrene-maleic anhydride resins.

[0111] Examples of the photo-curable compound include bifunctional monomers such as 1,6-hexanediol diacrylate, ethylene glycol diacrylate, neopentyl glycol diacrylate, triethylene glycol diacrylate, bis(acryloxyethoxy) bisphenol A, and 3-methylpentanediol diacrylate; polyfunctional monomers having a relatively low molecular weight, such as trimethylolpropane triacrylate, pentaerythritol triacrylate, tris[2-(meth)acryloyloxyethyl] isocyanurate, dipentaerythritol hexaacrylate, and dipentaerythritol pentaacrylate; and polyfunctional monomers having a relatively high molecular weight, such as polyester acrylates, polyurethane acrylates, and polyether acrylates.

[0112] Examples of the photopolymerization initiator include acetophenone, benzophenone, benzyldimethyl ketal, benzoyl peroxide, 2-chlorothioxanthone, 1,3-bis(4'-azidobenzal)-2-propane, 1,3-bis(4'-azidobenzal)-2-propane-2'-sulfonic acid, and 4,4'-diazidostilbene-2,2'-disulfonic acid. Examples of a commercially available photopolymerization initiator include "Irgacure (trademark)-184", "Irgacure (trademark)-369", and "Darocur (trademark)-1173" manufactured by BASF; "Lucirin-TPO" manufactured by BASF; "Kayacure (trademark) DETX" and "Kayacure (trademark) OA" manufactured by Nippon Kayaku Co., Ltd.; "Vicure 10" and "Vicure 55" manufactured by Stauffer; "Trigonal PI" manufactured by Akzo; "Sandoray 1000" manufactured by Sandoz; "DEAP" manufactured by Upjohn Co.; and "Biimidazole" manufactured by Kurogane Kasei Co., Ltd.

[0113] A publicly known photosensitizer can also be used together with the photopolymerization initiator. Examples of the photosensitizer include amines, urea compounds, compounds containing a sulfur atom, compounds containing a phosphorus atom, compounds containing a chlorine atom, nitriles, and other compounds containing a nitrogen atom. They can be used alone or in combination of two or more.

[0114] The mixing ratio of the photopolymerization initiator added is not particularly limited, but is preferably 0.1% to 30% by mass relative to the compound having a photopolymerizable or photo-curable functional group. If the ratio is less than 0.1%, the sensitivity during photocuring tends to decrease. If the ratio is more than 30%, a crystal of the photopolymerization initiator is precipitated when a pigment dispersion resist coating film is dried and thus the physical properties of the coating film may be degraded.

[0115] A photo-curable composition for forming pixel portions of a color filter can be prepared using the materials described above. Specifically, 300 to 1000 parts by mass of the organic solvent and 1 to 100 parts by mass of the dispersant relative to 100 parts by mass of the dye and/or pigment composition for color filters of the present invention are stirred and dispersed so as to be uniformly mixed with each other. Thus, a dye/pigment liquid can be prepared. Subsequently, 3 to 20 parts by mass in total of the thermoplastic resin and photo-curable compound relative to 1 part by mass of the pigment composition for color filters of the present invention, 0.05 to 3 parts by mass of the photopolymerization initiator relative to 1 part by mass of the photo-curable compound, and optionally an organic solvent are added to the pigment dispersion liquid and stirred and dispersed so as to be uniformly mixed with each other.

[0116] A publicly known organic solvent or aqueous alkali solution can be used as the developer. In particular, in the case where the photo-curable composition contains a thermoplastic resin or a photo-curable compound and at least one of the thermoplastic resin and photo-curable compound has an acid value and exhibits alkali solubility, washing with an aqueous alkali solution is effective for formation of color filter pixel portions.

[0117] The method for forming color filter pixel portions by a photolithography method has been described in detail. The color filter pixel portions formed by using the pigment composition for color filters of the present invention may be formed by another method such as an electrodeposition method, a transfer method, a micelle electrolysis method, a PVED (photovoltaic electrodeposition) method, an inkjet method, a reverse printing method, or a heat curing method to produce a color filter.

(Alignment film)

[0118] In the liquid crystal display device of the present invention, when an alignment film for aligning a liquid crystal composition needs to be formed on surfaces of first and second substrates that contact the liquid crystal composition, the alignment film is disposed between a color filter and a liquid crystal layer. However, the thickness of the alignment film is at most 100 nm or less, which does not completely block the interaction between a coloring agent such as a pigment constituting the color filter and a liquid crystal compound constituting the liquid crystal layer.

[0119] In a liquid crystal display device that does not use an alignment film, higher interaction occurs between a coloring agent such as a pigment constituting the color filter and a liquid crystal compound constituting the liquid crystal layer.

[0120] The alignment film can be composed of a transparent organic material such as polyimide, polyamide, BCB (benzocyclobutene polymer), or polyvinyl alcohol. In particular, the alignment film is preferably a polyimide alignment film formed by imidizing polyamic acid synthesized from a diamine such as an aliphatic or alicyclic diamine, e.g., p-phenylene diamine or 4,4'-diaminodiphenylmethane, an aliphatic or alicyclic tetracarboxylic acid anhydride such as butanetetracarboxylic acid anhydride or 2,3,5-tricarboxycyclopentylacetic acid anhydride, and an aromatic tetracarboxylic acid anhydride such as pyromellitic acid dianhydride. In this case, the alignment is generally provided by rubbing, but the alignment film can be used without providing alignment when used as a vertical alignment film or the like.

[0121] The alignment film can be composed of a material containing chalcone, cinnamate, cinnamoyl, or an azo group in a compound, and such a material may be used in combination with a material such as polyimide and polyamide. In this case, rubbing or an optical alignment technique may be used for the alignment film.

[0122] In the alignment film, a resin film is generally formed by applying the alignment film material onto a substrate by a method such as a spin coating method. A uniaxially stretching method, a Langmuir-Blodgett method, or the like can also be employed.

(Transparent electrode)

[0123] In the liquid crystal display device of the present invention, the transparent electrode can be composed of a material such as a conductive metal oxide. The metal oxide can be indium oxide (In_2O_3), tin oxide (SnO_2), zinc oxide (ZnO), indium tin oxide ($\text{In}_2\text{O}_3\text{-SnO}_2$), indium zinc oxide ($\text{In}_2\text{O}_3\text{-ZnO}$), niobium-added titanium dioxide ($\text{Ti}_{1-x}\text{Nb}_x\text{O}_2$), fluorine-doped tin oxide, graphene nanoribbon, or metal nanowire and is preferably zinc oxide (ZnO), indium tin oxide ($\text{In}_2\text{O}_3\text{-SnO}_2$), or indium zinc oxide ($\text{In}_2\text{O}_3\text{-ZnO}$). The transparent conductive film can be patterned by, for example, a photo-etching method or a method that uses a mask.

[0124] The liquid crystal display device of the present invention is particularly useful for active matrix driving liquid crystal display devices and can be applied to liquid crystal display devices with a TN mode, an IPS mode, a polymer-stabilized IPS mode, an FFS mode, an OCB mode, a VA mode, or an ECB mode.

[0125] By combining a backlight, the liquid crystal display device is used in various applications such as monitors of liquid crystal televisions and personal computers, displays of cellular phones and smart phones, notebook computers, mobile information terminals, and digital signage. Examples of the backlight include a cold-cathode tube backlight, and a pseudo-white backlight with two wavelength peaks and a backlight with three wavelength peaks that use a light-emitting diode composed of an inorganic material or an organic EL element.

EXAMPLES

[0126] The present invention will now be further described in detail based on Examples. In compositions of Examples and Comparative Examples below, "%" means "% by mass".

[0127] In Examples, the measured properties are as follows.

T_{ni} : nematic phase-isotropic liquid phase transition temperature ($^{\circ}\text{C}$)

Δn : refractive index anisotropy at 25°C

$\Delta\epsilon$: dielectric anisotropy at 25°C

η : viscosity ($\text{mPa}\cdot\text{s}$) at 20°C

$\gamma 1$: rotational viscosity ($\text{mPa}\cdot\text{s}$) at 25°C

VHR: voltage holding ratio (%) at 70°C

(a value, which is expressed as a percentage, of the ratio of a measured voltage to an initial voltage, the measured voltage being obtained by injecting a liquid crystal composition into a cell having a thickness of $3.5\ \mu\text{m}$ and performing measurement at an application voltage of 5 V, a frame time of 200 ms, and a pulse duration of $64\ \mu\text{s}$)

ID: ion density (pC/cm^2) at 70°C

(an ion density obtained by injecting a liquid crystal composition into a cell having a thickness of $3.5\ \mu\text{m}$ and performing measurement at an application voltage of 20 V and a frequency of 0.05 Hz using MTR-1 (manufactured

by TOYO Corporation))

Image sticking:

5 **[0128]** Image sticking of a liquid crystal display element was evaluated as follows. A predetermined fixed pattern was displayed in a display area for 1000 hours, and a uniform image was then displayed on the full screen. The level of a residual image of the fixed pattern was evaluated through visual inspection on the basis of the four-level criteria described below.

- 10 A: No residual image was observed.
 B: A residual image was slightly observed, but was at an acceptable level.
 C: A residual image was observed, and was at an unacceptable level.
 D: A residual image was observed, and was at a very poor level.

15 **[0129]** In Examples, the following abbreviations are used for the description of compounds.

(Ring structure)

[0130]

20

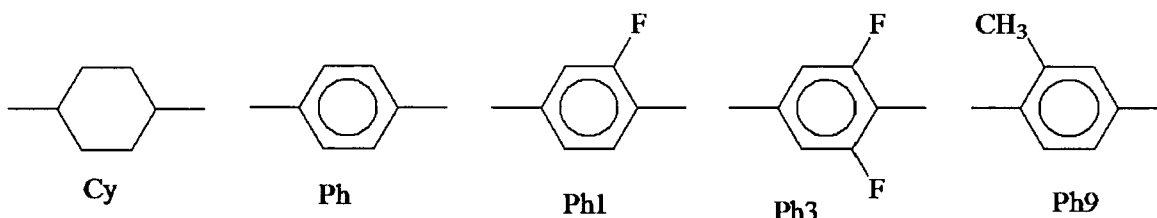

30

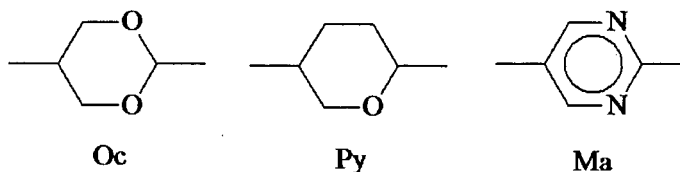

35

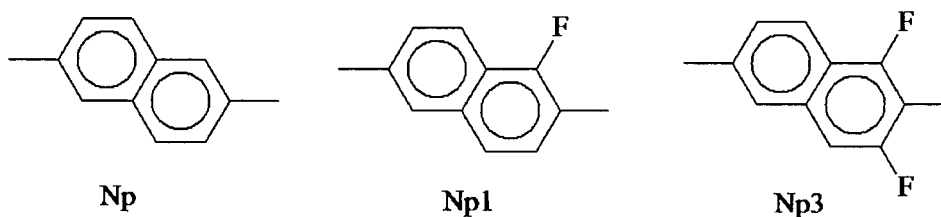

(Side chain structure and linking structure)

45

[0131]

[Table 1]

50

n (number) at terminal	C_nH_{2n+1} -
-2-	$-CH_2CH_2-$
-1O-	$-CH_2O-$
-O1-	$-OCH_2-$
-V-	$-CO-$
-VO-	$-COO-$

55

EP 2 796 922 B1

(continued)

n (number) at terminal	$C_nH_{2n+1}-$
-CFFO-	$-CF_2O-$
-F	-F
-Cl	-Cl
-CN	$-C\equiv N$
-OCFFF	$-OCF_3$
-CFFF	$-CF_3$
-On	$-OC_nH_{2n+1}-$
-T-	$-C\equiv C-$
-N-	$-CH=N-N=CH-$
ndm-	$C_2H_{2n+1}-HC=CH-(CH_2)_{m-1}-$
-ndm	$-(CH_2)_{n-1}-HC=CH-C_mH_{2m+1}$
ndmO-	$C_nH_{2n+1}-HC=CH-(CH_2)_{m-1}O-$
-Ondm	$-O-(CH_2)_{n-1}-HC=CH-C_mH_{2m+1}$
-ndm-	$-(CH_2)_{n-1}-HC=CH-(CH_2)_{m-1}-$

[Production of color filter]

[Preparation of colored composition]

[Red dye-colored composition 1]

[0132] Into a plastic bottle, 10 parts of a red dye 1 (C.I. Solvent Red 124), 55 parts of propylene glycol monomethyl ether acetate, and 0.3 to 0.4 mm ϕ SEPR beads were inserted, and they were dispersed with a paint conditioner (manufactured by Toyo Seiki Seisaku-sho, Ltd.) for four hours and then filtered with a 5- μ m filter to obtain a dye-colored liquid. Then, 75.00 parts of the dye-colored liquid, 5.50 parts of polyester acrylate resin (Aronix (trademark) M7100 manufactured by TOAGOSEI CO., LTD.), 5.00 parts of dipentaerythritol hexaacrylate (KAYARAD (trademark) DPHA manufactured by Nippon Kayaku Co., Ltd.), 1.00 part of benzophenone (KAYACURE (trademark) BP-100 manufactured by Nippon Kayaku Co., Ltd.), and 13.5 parts of UCAR Ester EEP were stirred with a mixer and filtered with a filter having a pore size of 1.0 μ m to obtain a red dye-colored composition 1.

[Red dye-colored composition 2]

[0133] A red dye-colored composition 2 was prepared in the same manner as above, except that 8 parts of the red dye 1 (C.I. Solvent Red 124) and 2 parts of a yellow dye 1 (C.I. Solvent Yellow 21) were used instead of 10 parts of the red dye 1 of the red dye-colored composition 1.

[Red dye-colored composition 3]

[0134] A red dye-colored composition 3 was prepared in the same manner as above, except that 10 parts of a red dye 2 (C.I. Solvent Red 1) was used instead of 10 parts of the red dye 1 of the red dye-colored composition 1.

[Green dye-colored composition 1]

[0135] A green dye-colored composition 1 was prepared in the same manner as above, except that 10 parts of a green dye 1 (C.I. Solvent Green 7) was used instead of 10 parts of the red dye 1 of the red dye-colored composition 1.

EP 2 796 922 B1

[Blue dye-colored composition 1]

5 **[0136]** A blue dye-colored composition 1 was prepared in the same manner as above, except that 10 parts of a blue dye 1 (C.I. Solvent Blue 7) was used instead of 10 parts of the red dye 1 of the red dye-colored composition 1.

[Blue dye-colored composition 2]

10 **[0137]** A blue dye-colored composition 2 was prepared in the same manner as above, except that 7 parts of the blue dye 1 (C.I. Solvent Blue 7) and 3 parts of a purple dye 1 (C.I. Basic Violet 10) were used instead of 10 parts of the blue dye 1 of the blue dye-colored composition 1.

[Blue dye-colored composition 3]

15 **[0138]** A blue dye-colored composition 3 was prepared in the same manner as above, except that 10 parts of a blue dye 2 (C.I. Solvent Blue 12) was used instead of 7 parts of the blue dye 1 and 3 parts of the purple dye 1 of the blue dye-colored composition 2.

[Yellow dye-colored composition 1]

20 **[0139]** A yellow dye-colored composition 1 was prepared in the same manner as above, except that 10 parts of a yellow dye 1 (C.I. Solvent Yellow 21) was used instead of 10 parts of the red dye 1 of the red dye-colored composition 1.

[Yellow dye-colored composition 2]

25 **[0140]** A yellow dye-colored composition 2 was prepared in the same manner as above, except that 10 parts of a yellow dye 4 (C.I. Solvent Yellow 2) was used instead of 10 parts of the yellow dye 1 of the yellow dye-colored composition 1.

[Red pigment-colored composition 1]

30 **[0141]** Into a plastic bottle, 10 parts of a red pigment 1 (C.I. Pigment Red 254, "IRGAPHOR RED BT-CF" manufactured by BASF), 55 parts of propylene glycol monomethyl ether acetate, 7.0 parts of DISPERBYK LPN21116 (manufactured by BYK-Chemie GmbH), and 0.3 to 0.4 mm ϕ zirconia beads "ER-120S" manufactured by Saint-Gobain were inserted, and they were dispersed with a paint conditioner (manufactured by Toyo Seiki Seisaku-sho, Ltd.) for four hours and then
35 filtered with a 1- μ m filter to obtain a pigment dispersion liquid. Then, 75.00 parts of the pigment dispersion liquid, 5.50 parts of polyester acrylate resin (Aronix (trademark) M7100 manufactured by TOAGOSEI CO., LTD.), 5.00 parts of dipentaerythritol hexaacrylate (KAYARAD (trademark) DPHA manufactured by Nippon Kayaku Co., Ltd.), 1.00 part of benzophenone (KAYACURE (trademark) BP-100 manufactured by Nippon Kayaku Co., Ltd.), and 13.5 parts of UCAR Ester EEP were stirred with a mixer and filtered with a filter having a pore size of 1.0 μ m to obtain a red pigment-colored
40 composition 1.

[Red pigment-colored composition 2]

45 **[0142]** A red pigment-colored composition 2 was prepared in the same manner as above, except that 6 parts of the red pigment 1, 2 parts of a red pigment 2 (C.I. Pigment Red 177, FASTOGEN SUPER RED ATY-TR manufactured by DIC Corporation), and 2 parts of a yellow pigment 2 (C.I. Pigment Yellow 139) were used instead of 10 parts of the red pigment 1 of the red pigment-colored composition 1.

[Green pigment-colored composition 1]

50 **[0143]** A green pigment-colored composition 1 was prepared in the same manner as above, except that 10 parts of a green pigment 1 (halogenated aluminum phthalocyanine (AlClPcBr14ClH)) was used instead of 10 parts of the red pigment 1 of the red pigment-colored composition 1.

55 [Green pigment-colored composition 2]

[0144] A green pigment-colored composition 2 was prepared in the same manner as above, except that 10 parts of a green pigment 2 (halogenated zinc phthalocyanine (ZnPcBr14ClH)) was used instead of 10 parts of the green pigment

1 of the green pigment-colored composition 1.

[Green pigment-colored composition 3]

5 **[0145]** A green pigment-colored composition 3 was prepared in the same manner as above, except that 6 parts of a green pigment 3 (C.I. Pigment Green 58, FASTOGEN GREEN A110 manufactured by DIC Corporation) and 4 parts of a yellow pigment 1 (C.I. Pigment Yellow 150, FANCHON FAST YELLOW E4GN manufactured by LANXESS) were used instead of 10 parts of the green pigment 1 of the green pigment-colored composition 1.

10 [Green pigment-colored composition 4]

[0146] A green pigment-colored composition 4 was prepared in the same manner as above, except that 4 parts of a green pigment 4 (C.I. Pigment Green 58, FASTOGEN GREEN A310 manufactured by DIC Corporation) and 6 parts of a yellow pigment 3 (C.I. Pigment YELLOW 138) were used instead of 6 parts of the green pigment 3 and 4 parts of the yellow pigment 1 of the green pigment-colored composition 3.

[Blue pigment-colored composition 1]

20 **[0147]** A blue pigment-colored composition 1 was prepared in the same manner as above, except that 9 parts of a blue pigment 1 (C.I. Pigment Blue 15:6, "FASTOGEN BLUE EP-210" manufactured by DIC Corporation) and 1 part of a purple pigment 1 (C.I. Pigment Violet 23) were used instead of 10 parts of the red pigment 1 of the red pigment-colored composition 1.

[Blue pigment/dye-colored composition 2]

25 **[0148]** A blue pigment/dye-colored composition 2 was prepared in the same manner as above, except that 1 part of a purple dye 1 (C.I. Basic Violet 10) was used instead of 1 part of the purple pigment 1 of the blue pigment-colored composition 1.

30 [Yellow pigment-colored composition 1]

[0149] A yellow pigment-colored composition 1 was prepared in the same manner as above, except that 10 parts of the yellow pigment 1 (C.I. Pigment Yellow 150, FANCHON FAST YELLOW E4GN manufactured by LANXESS) was used instead of 10 parts of the red pigment 1 of the red pigment-colored composition 1.

35 [Production of color filter]

[0150] The red colored composition was applied by spin coating onto a glass substrate on which a black matrix was formed in advance, so as to have a thickness of 2 μm . The red colored composition was dried at 70°C for 20 minutes and then exposed to ultraviolet rays through a photomask in a striped pattern using an exposure device equipped with an ultrahigh-pressure mercury lamp. The exposed product was subjected to spray development with an alkali developer for 90 seconds, washed with ion-exchanged water, and air-dried. Subsequently, the resultant product was post-baked in a clean oven at 230°C for 30 minutes to form a red pixel, which was a striped colored layer, on the transparent substrate.

40 **[0151]** Next, the green colored composition was applied by spin coating in the same manner so as to have a thickness of 2 μm . After drying, exposure and development were performed with an exposure device so that a striped colored layer was formed in a place shifted from the place of the red pixel. Thus, a green pixel adjacent to the red pixel was formed.

[0152] Next, the blue colored composition was applied by spin coating in the same manner so as to have a thickness of 2 μm to form a blue pixel adjacent to the red pixel and green pixel. Thus, a color filter including red, green, and blue striped pixels was produced on the transparent substrate.

50 **[0153]** When necessary, the yellow colored composition was applied by spin coating in the same manner so as to have a thickness of 2 μm to form a yellow pixel adjacent to the green pixel and a blue pixel. Thus, a color filter including red, green, blue, and yellow striped pixels was produced on the transparent substrate.

[0154] Color filters 1 to 4 and a comparative color filter 1 were produced using dye-colored compositions or pigment-colored compositions listed in Table 2.

55

EP 2 796 922 B1

[Table 2]

	Color filter 1	Color filter 2	Color filter 3	Color filter 4	Comparative color filter 1
R pixel portion	Red dye-colored composition 1	Red dye-colored composition 2	Red pigment-colored composition 1	Red pigment-colored composition 2	Red dye-colored composition 3
G pixel portion	Green pigment-colored composition 1	Green pigment-colored composition 2	Green pigment-colored composition 3	Green pigment-colored composition 4	Green dye-colored composition 1
B pixel portion	Blue dye-colored composition 1	Blue dye-colored composition 2	Blue pigment-colored composition 1	Blue pigment/dye-colored composition 2	Blue dye-colored composition 3
Y pixel portion	None	Yellow dye-colored composition 1	None	Yellow pigment-colored composition 1	Yellow dye-colored composition 2

[0155] In each of the pixel portions of the color filter, the x value and y value in the CIE 1931 XYZ color system with use of a C light source were measured with a microspectrophotometer including a microscope MX-50 manufactured by Olympus Corporation and a spectrophotometer MCPD-3000 manufactured by Otsuka Electronics Co., Ltd. Table below shows the results.

[Table 3]

	Color filter 1 (x, y)	Color filter 2 (x, y)	Color filter 3 (x, y)	Color filter 4 (x, y)	Comparative color filter (x, y)
R pixel portion	(0.63, 0.29)	(0.62, 0.31)	(0.62, 0.32)	(0.63, 0.33)	(0.59, 0.30)
G pixel portion	(0.26, 0.64)	(0.22, 0.66)	(0.24, 0.72)	(0.22, 0.70)	(0.20, 0.55)
B pixel portion	(0.17, 0.10)	(0.13, 0.14)	(0.14, 0.10)	(0.15, 0.07)	(0.14, 0.15)
Y pixel portion		(0.47, 0.51)		(0.48, 0.50)	(0.49, 0.48)

(Examples 1 to 4)

[0156] An electrode structure was formed on at least one of first and second substrates, and an alignment film having a horizontal alignment property was formed on each of surfaces of the first and second substrates facing each other. Then, a weak rubbing treatment was performed, an IPS cell was made, and a liquid crystal composition 1 described below was sandwiched between the first substrate and the second substrate. Table 4 shows the physical properties of the liquid crystal composition 1. Subsequently, liquid crystal display devices of Examples 1 to 4 were produced using the color filters 1 to 4 listed in Table 2 ($d_{\text{gap}} = 4.0 \mu\text{m}$, alignment film AL-1051). The VHR and ID of the produced liquid crystal display devices were measured. The image sticking of the produced liquid crystal display devices was also evaluated. Table 5 shows the results.

Chemical structure

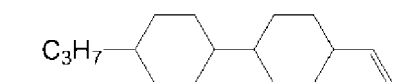

Proportion

48%

Abbreviation

3-Cy-Cy-1d0

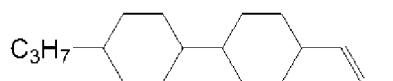

4%

3-Cy-Cy-1d1

EP 2 796 922 B1

(continued)

Chemical structure

Proportion

Abbreviation

5

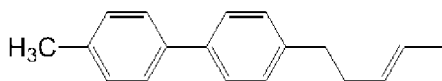

8%

1-Ph-Ph-3d1

10

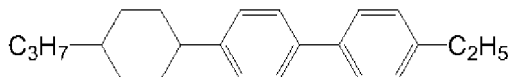

5%

3-Cy-Ph-Ph-2

15

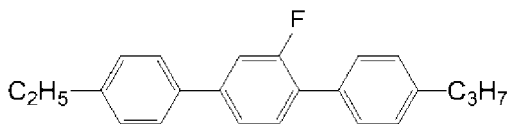

5%

2-Ph-Ph1-Ph-3

20

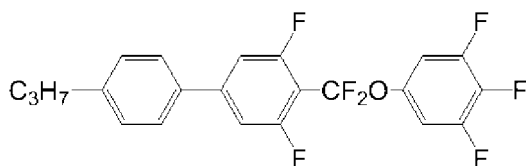

2%

3-Ph-Ph3-CFFO-Ph3-F

25

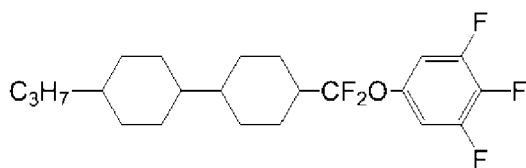

3%

3-Cy-Cy-CFFO-Ph3-F

35

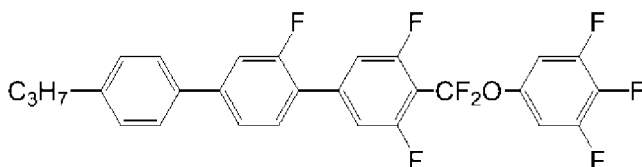

7%

3-Ph-Ph1-Ph3-CFFO-Ph3-F

40

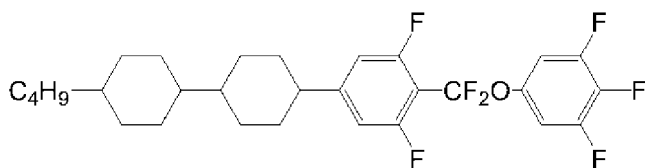

5%

4-Cy-Cy-Ph3-CFFO-Ph3-F

50

[Table 4]

$T_{NI}/^{\circ}\text{C}$	75.8
Δn	0.112
no	1.488
ϵ_{\perp}	5.5
$\Delta\epsilon$	2.9

55

EP 2 796 922 B1

(continued)

$\eta/\text{mPa}\cdot\text{s}$	13.5
--------------------------------	------

5

[Table 5]

	Example 1	Example 2	Example 3	Example 4
Liquid crystal composition	Liquid crystal composition 1	Liquid crystal composition 1	Liquid crystal composition 1	Liquid crystal composition 1
Color filter	Color filter 1	Color filter 2	Color filter 3	Color filter 4
VHR	99.3	99.5	99.8	99.7
ID	49	28	12	15
Image sticking	B	A	A	A

10

15

[0157] It was found that the liquid crystal composition 1 had a liquid crystal phase temperature range of 75.8°C, which was practical for use as a liquid crystal composition for TVs, a high absolute value of dielectric anisotropy, low viscosity, and an appropriate value of Δn .

20

[0158] In the liquid crystal display devices of Examples 1 to 4, high VHRs and low IDs were achieved. In the evaluation of image sticking, no residual image was observed or a residual image was slightly observed, which was at an acceptable level.

25

(Examples 5 to 12)

[0159] Liquid crystal compositions 2 and 3 listed in Table 5 were sandwiched as in Example 1. Liquid crystal display devices of Examples 5 to 12 were produced using the color filters listed in Table 2 and the VHR and ID were measured. The image sticking of the liquid crystal display devices was also evaluated. Tables 7 and 8 show the results.

30

[Table 6]

Liquid crystal composition 2		Liquid crystal composition 3	
Name of compound	Content (%)	Name of compound	Content (%)
4-Cy-Cy-1d0	15	5-Cy-Cy-1d0	5
0d1-Cy-Cy-Ph-1	4	3-Cy-Cy-1d1	10
0d3-Cy-Cy-Ph-1	14	0d1-Cy-Cy-Ph-1	8
3-Cy-Ph-Ph-Cy-3	3	5-Cy-Cy-Ph-01	6
3-Cy-Ph-Ph1-Cy-3	4	2-Ph-Ph1-Ph-3	8
1-Cy-Cy-Ph3-F	9	2-Cy-Cy-Ph3-F	11
2-Cy-Ph-Ph3-F	10	3-Cy-Cy-Ph3-F	15
3-Cy-Ph-Ph3-F	10	5-Cy-Cy-Ph3-F	5
5-Cy-Ph-Ph3-F	5	3-Cy-Ph-Ph3-F	6
0d1-Cy-Cy-Ph1-F	8	3-Cy-Ph-Ph1-F	9
3-Cy-Cy-Ph1-Ph3-F	8	4-Cy-Cy-Ph-OCFFF	4
2-Ph-Ph3-CFFO-Ph3-F	4	3-Cy-Cy-CFFO-Ph3-F	7
3-Ph-Ph3-CFFO-Ph3-F	6	5-Cy-Cy-CFFO-Ph3-F	4
$T_{ni}/^{\circ}\text{C}$	100.7	3-Cy-Cy-Ph1-Ph3-F	2
Δn	0.094	$T_{ni}/^{\circ}\text{C}$	103.2
$\Delta\varepsilon$	8.0	Δn	0.102
$\gamma_1/\text{mPa}\cdot\text{s}$	108	$\Delta\varepsilon$	7.1
$\eta/\text{mPa}\cdot\text{s}$	22.2	$\gamma_1/\text{mPa}\cdot\text{s}$	96
		$\eta/\text{mPa}\cdot\text{s}$	20.8

35

40

45

50

55

[Table 7]

	Example 5	Example 6	Example 7	Example 8
Liquid crystal composition	Liquid crystal composition 2	Liquid crystal composition 2	Liquid crystal composition 2	Liquid crystal composition 2
Color filter	Color filter 1	Color filter 2	Color filter 3	Color filter 4
VHR	99.2	99.5	99.8	99.6
ID	79	32	23	14
Image sticking	B	A	A	A

[Table 8]

	Example 9	Example 10	Example 11	Example 12
Liquid crystal composition	Liquid crystal composition 3	Liquid crystal composition 3	Liquid crystal composition 3	Liquid crystal composition 3
Color filter	Color filter 1	Color filter 2	Color filter 3	Color filter 4
VHR	99.3	99.5	99.8	99.8
ID	47	38	12	12
Image sticking	A	A	A	A

[0160] In the liquid crystal display devices of Examples 5 to 12, high VHRs and low IDs were achieved. In the evaluation of image sticking, no residual image was observed or a residual image was slightly observed, which was at an acceptable level.

(Examples 13 to 24)

[0161] Liquid crystal compositions 4 to 6 listed in Table 9 were sandwiched as in Example 1. Liquid crystal display devices of Examples 13 to 24 were produced using the color filters listed in Table 2 and the VHR and ID were measured. The image sticking of the liquid crystal display devices was also evaluated. Tables 10 to 12 show the results.

[Table 9]

Liquid crystal composition 4		Liquid crystal composition 5		Liquid crystal composition 6	
Name of compound	Content (%)	Name of compound	Content (%)	Name of compound	Content (%)
5-Cy-Cy-1d0	15	5-Cy-Cy-1d0	10	5-Cy-Cy-1d0	12
3-Cy-Cy-1d1	2	3-Cy-Cy-1d1	5	3-Cy-Cy-1d1	25
0d1-Cy-Cy-Ph-1	12	0d1-Cy-Cy-Ph-1	8	3-Cy-Cy-1d1	12
2-Ph-Ph1-Ph-3	3	0d3-Cy-Cy-Ph-1	12	0d1-Cy-Cy-Ph-1	4
2-Ph-Ph1-Ph-4	3	2-Ph-Ph1-Ph-5	2	0d3-Cy-Cy-Ph-1	9
2-Cy-Cy-Ph3-F	8	3-Cy-Ph-Ph-Cy-3	3	2-Ph-Ph1-Ph3-F	5
2-Cy-Ph-Ph3-F	3	3-Cy-Ph-Ph1-Cy-3	3	3-Ph-Ph1-Ph3-F	9
3-Cy-Ph-Ph3-F	9	1-Cy-Cy-Ph3-F	9	2-Ph-Ph3-CFFO-Ph3-F	4
4-Cy-Cy-Ph-OCFFF	14	2-Cy-Cy-Ph3-F	10	3-Ph-Ph3-CFFO-Ph3-F	6
3-Ph-Ph3-CFFO-Ph3-F	11	3-Cy-Cy-Ph3-F	6	3-Cy-Cy-CFFO-Ph3-F	2
2-Cy-Cy-CFFO-Ph3-F	9	5-Cy-Cy-Ph3-F	5	5-Cy-Cy-CFFO-Ph3-F	3
3-Cy-Cy-CFFO-Ph3-F	8	0d1-Cy-Cy-Ph1-F	8	3-Cy-Cy-Ph1-Ph3-F	9
3-Cy-Cy-Ph1-Ph3-F	3	2-Ph-Ph3-CFFO-Ph3-F	4		
$T_{nl}/^{\circ}\text{C}$	90.2	3-Ph-Ph3-CFFO-Ph3-F	6	$T_{nl}/^{\circ}\text{C}$	77.4
Δn	0.098	3-Cy-Cy-Ph1-Ph3-F	9	Δn	0.101
$\Delta\varepsilon$	9.1			$\Delta\varepsilon$	7.0
$\gamma_1/\text{mPa}\cdot\text{s}$	90	$T_{nl}/^{\circ}\text{C}$	110.0	$\gamma_1/\text{mPa}\cdot\text{s}$	86
$\eta/\text{mPa}\cdot\text{s}$	18.1	Δn	0.099	$\eta/\text{mPa}\cdot\text{s}$	14.2
		$\Delta\varepsilon$	8.3		
		$\gamma_1/\text{mPa}\cdot\text{s}$	112		
		$\eta/\text{mPa}\cdot\text{s}$	23.4		

[Table 10]

	Example 13	Example 14	Example 15	Example 16
Liquid crystal composition	Liquid crystal composition 4	Liquid crystal composition 4	Liquid crystal composition 4	Liquid crystal composition 4
Color filter	Color filter 1	Color filter 2	Color filter 3	Color filter 4
VHR	99.3	99.5	99.8	99.7
ID	58	44	11	13
Image sticking	A	A	A	A

[Table 11]

	Example 17	Example 18	Example 19	Example 20
Liquid crystal composition	Liquid crystal composition 5	Liquid crystal composition 5	Liquid crystal composition 5	Liquid crystal composition 5
Color filter	Color filter 1	Color filter 2	Color filter 3	Color filter 4
VHR	99.3	99.4	99.7	99.6
ID	64	49	14	13
Image sticking	B	A	A	A

[Table 12]

	Example 21	Example 22	Example 23	Example 24
Liquid crystal composition	Liquid crystal composition 6	Liquid crystal composition 6	Liquid crystal composition 6	Liquid crystal composition 6
Color filter	Color filter 1	Color filter 2	Color filter 3	Color filter 4
VHR	99.3	99.5	99.7	99.7
ID	68	40	15	13
Image sticking	B	A	A	A

[0162] In the liquid crystal display devices of Examples 13 to 24, high VHRs and low IDs were achieved. In the evaluation of image sticking, no residual image was observed or a residual image was slightly observed, which was at an acceptable level.

(Examples 25 to 36)

[0163] An electrode structure was formed on each of first and second substrates, and an alignment film having a horizontal alignment property was formed on each of surfaces of the first and second substrates facing each other. Then, a weak rubbing treatment was performed, a TN cell was made, and liquid crystal compositions 7 to 9 described in Table 13 were sandwiched between the first substrate and the second substrate. Subsequently, liquid crystal display devices of Examples 25 to 36 were produced using the color filters 1 to 4 listed in Table 2 ($d_{\text{gap}} = 3.5 \mu\text{m}$, alignment film SE-7492). The VHR and ID of the produced liquid crystal display devices were measured. The image sticking of the produced liquid crystal display devices was also evaluated. Tables 14 to 16 show the results.

[Table 13]

Liquid crystal composition 7			Liquid crystal composition 8			Liquid crystal composition 9		
Name of compound	Content (%)		Name of compound	Content (%)		Name of compound	Content (%)	
3-Cy-Cy-1d0	38		3-Cy-Cy-1d0	38		3-Cy-Cy-1d0	30	
3-Cy-Cy-1d1	9		3-Cy-Cy-1d1	14		3-Cy-Cy-1d1	17	
0d1-Cy-Cy-Ph-1	16		0d3-Cy-Cy-Ph-1	8		0d1-Cy-Cy-Ph-1	7	
0d3-Cy-Cy-Ph-1	4		3-Ph-Ph3-CFFO-Ph3-F	9		0d3-Cy-Cy-Ph-1	7	
2-Ph-Ph3-CFFO-Ph3-F	2		3-Cy-Cy-CFFO-Ph3-F	15		3-Cy-Cy-Ph-2	2	
3-Ph-Ph3-CFFO-Ph3-F	12		3-Ph-Ph1-Ph3-CFFO-h3-F	2		2-Ph-Ph1-Ph-4	2	
3-Cy-Cy-CFFO-Ph3-F	7		4-Ph-Ph1-Ph3-CFFO-h3-F	7		2-Ph-Ph1-Ph3-F	8	
3-Ph-Ph-Ph1-Ph3-F	1		5-Ph-Ph1-Ph3-CFFO-h3-F	7		3-Ph-Ph1-Ph3-F	12	
3-Ph-Ph1-Ph3-CFFO-Ph3-F	2		$T_{nl}/^{\circ}\text{C}$	81.8		3-Ph-Ph3-Ph3-F	4	
2-Py-Ph-Ph3-CFFO-Ph3-F	9		Δn	0.099		3-Cy-Cy-Ph1-CFFO-Ph3-F	11	
$T_{nl}/^{\circ}\text{C}$	76.0		$\Delta\varepsilon$	8.0		$T_{nl}/^{\circ}\text{C}$	75.0	
Δn	0.097		$\gamma 1/\text{mPa}\cdot\text{s}$	83		Δn	0.112	
$\Delta\varepsilon$	6.8		$\eta/\text{mPa}\cdot\text{s}$	14.6		$\Delta\varepsilon$	8.7	
$\gamma 1/\text{mPa}\cdot\text{s}$	83					$\gamma 1/\text{mPa}\cdot\text{s}$	87	
$\eta/\text{mPa}\cdot\text{s}$	14.5					$\eta/\text{mPa}\cdot\text{s}$	15.2	

[Table 14]

	Example 25	Example 26	Example 27	Example 28
Liquid crystal composition	Liquid crystal composition 7	Liquid crystal composition 7	Liquid crystal composition 7	Liquid crystal composition 7
Color filter	Color filter 1	Color filter 2	Color filter 3	Color filter 4
VHR	99.3	99.4	99.6	99.7
ID	75	42	19	12
Image sticking	B	A	A	A

[Table 15]

	Example 29	Example 30	Example 31	Example 32
Liquid crystal composition	Liquid crystal composition 8	Liquid crystal composition 8	Liquid crystal composition 8	Liquid crystal composition 8
Color filter	Color filter 1	Color filter 2	Color filter 3	Color filter 4
VHR	99.2	99.5	99.7	99.7
ID	79	60	11	14
Image sticking	B	A	A	A

[Table 16]

	Example 33	Example 34	Example 35	Example 36
Liquid crystal composition	Liquid crystal composition 9	Liquid crystal composition 9	Liquid crystal composition 9	Liquid crystal composition 9
Color filter	Color filter 1	Color filter 2	Color filter 3	Color filter 4
VHR	99.3	99.5	99.8	99.8
ID	67	34	12	15
Image sticking	A	A	A	A

[0164] In the liquid crystal display devices of Examples 25 to 36, high VHRs and low IDs were achieved. In the evaluation of image sticking, no residual image was observed or a residual image was slightly observed, which was at an acceptable level.

(Examples 37 to 44)

[0165] An electrode structure was formed on at least one of first and second substrates, and an alignment film having a horizontal alignment property was formed on each of surfaces of the first and second substrates facing each other. Then, a weak rubbing treatment was performed, an FFS cell was made, and liquid crystal compositions 10 and 11 described in Table 17 were sandwiched between the first substrate and the second substrate. Subsequently, liquid crystal display devices of Examples 37 to 44 were produced using the color filters 1 to 4 listed in Table 2 ($d_{\text{gap}} = 4.0 \mu\text{m}$, alignment film AL-1051). The VHR and ID of the produced liquid crystal display devices were measured. The image sticking of the produced liquid crystal display devices was also evaluated. Tables 18 and 19 show the results.

EP 2 796 922 B1

[Table 17]

Liquid crystal composition 10		Liquid crystal composition 11	
Name of compound	Content (%)	Name of compound	Content (%)
3-Cy-Cy-1d0	39	3-Cy-Cy-1d0	44
3-Cy-Cy-1d1	7	3-Cy-Cy-1d1	3
0d1-Cy-Cy-Ph-1	11	2-Ph-Ph-3d1	13
2-Ph-Ph1-Ph-3	8	3-Cy-Ph-Ph-2	7
2-Ph-Ph1-Ph-5	8	2-Ph-Ph1-Ph-3	8
3-Ph-Ph3-CFFO-Ph3-F	10	3-Ph-Ph1-Ph-3	7
3-Cy-Cy-Ph-Ph3-F	6	3-Ph-Ph1-Ph3-CFFO-Ph3-F	9
4-Ph-Ph1-Ph3-CFFO-Ph3-F	11	4-Cy-Cy-Ph1-CFFO-Ph3-F	3
$T_{ni}/^{\circ}\text{C}$	76.0	3-Cy-Ph3-Ph1-OCFFF	6
Δn	0.114	$T_{ni}/^{\circ}\text{C}$	77.9
$\Delta\varepsilon$	6.0	Δn	0.131
$\gamma_1/\text{mPa}\cdot\text{s}$	77	$\Delta\varepsilon$	4.6
$\eta/\text{mPa}\cdot\text{s}$	13.3	$\gamma_1/\text{mPa}\cdot\text{s}$	74
		$\eta/\text{mPa}\cdot\text{s}$	124

[Table 18]

	Example 37	Example 38	Example 39	Example 40
Liquid crystal composition	Liquid crystal composition 10	Liquid crystal composition 10	Liquid crystal composition 10	Liquid crystal composition 10
Color filter	Color filter 1	Color filter 2	Color filter 3	Color filter 4
VHR	99.3	99.4	99.6	99.7
ID	72	49	22	15
Image sticking	B	A	A	A

[Table 19]

	Example 41	Example 42	Example 43	Example 44
Liquid crystal composition	Liquid crystal composition 11	Liquid crystal composition 11	Liquid crystal composition 11	Liquid crystal composition 11
Color filter	Color filter 1	Color filter 2	Color filter 3	Color filter 4
VHR	99.3	99.5	99.7	99.7
ID	66	52	12	16
Image sticking	A	A	A	A

[0166] In the liquid crystal display devices of Examples 37 to 44, high VHRs and low IDs were achieved. In the evaluation of image sticking, no residual image was observed or a residual image was slightly observed, which was at an acceptable level.

(Examples 45 to 56)

[0167] Liquid crystal compositions 12 to 14 listed in Table 20 were sandwiched as in Example 37. Liquid crystal display devices of Examples 45 to 56 were produced using the color filters listed in Table 2 and the VHR and ID were measured. The image sticking of the liquid crystal display devices was also evaluated. Tables 21 to 23 show the results.

5
10
15
20
25
30
35
40
45
50
55

[Table 20]

Liquid crystal composition 12		Liquid crystal composition 13		Liquid crystal composition 14	
Name of compound	Content (%)	Name of compound	Content (%)	Name of compound	Content (%)
3-Cy-Cy-1d0	47	3-Cy-Cy-1d0	29	3-Cy-Cy-1d0	10
3-Cy-Cy-1d1	9	5-Cy-Cy-1d1	8	3-Cy-Cy-1d1	6
3-Cy-Cy-Ph-2	7	3-Cy-Cy-1d1	13	3-Cy-Cy-1d1-F	28
2-Ph-Ph1-Ph-3	4	5-Ph-Ph-1	2	0d1-Cy-Cy-Ph-1	11
2-Ph-Ph1-Ph-5	7	2-Ph-Ph1-Ph-3	6	0d3-Cy-Cy-Ph-1	10
3-Cy-Ph-Ph-Cy-3	2	2-Ph-Ph1-Ph-4	6	2-Ph-Ph1-Ph-3	10
2-Ph-Ph1-Ph-3	6	2-Ph-Ph1-Ph-5	6	2-Ph-Ph1-Ph-5	10
3-Ph-Ph1-Ph-3	7	3-Cy-Ph-Ph-Cy-3	4	5-Cy-Ph-Ph1-Ph-2	2
3-Ph-Ph3-CFFO-Ph3-F	2	3-Ph-Ph1-Ph3-F	9	3-Ph-Ph3-CFFO-Ph3-F	7
3-Cy-Cy-Ph1-Ph3-F	2	2-Ph-Ph3-Ph3-F	7	3-Cy-Cy-Ph1-CFFO-Ph3-F	6
3-Cy-Ph-Ph3-Ph1-OCFFF	7	3-Ph-Ph3-CFFO-Ph3-F	4		
$T_{ni}/^{\circ}\text{C}$	80.6	3-Cy-Ph-Cl	3	$T_{ni}/^{\circ}\text{C}$	80.0
Δn	0.122	3-Cy-Cy-Ph1-Ph3-F	3	Δn	0.110
$\Delta\varepsilon$	6.0			$\Delta\varepsilon$	5.9
$\gamma_1/\text{mPa}\cdot\text{s}$	65	$T_{ni}/^{\circ}\text{C}$	74.9	$\gamma_1/\text{mPa}\cdot\text{s}$	68
$\eta/\text{mPa}\cdot\text{s}$	11.1	Δn	0.121	$\eta/\text{mPa}\cdot\text{s}$	11.6
		$\Delta\varepsilon$	4.1		
		$\gamma_1/\text{mPa}\cdot\text{s}$	60		
		$\eta/\text{mPa}\cdot\text{s}$	10.8		

[Table 21]

	Example 45	Example 46	Example 47	Example 48
Liquid crystal composition	Liquid crystal composition 12	Liquid crystal composition 12	Liquid crystal composition 12	Liquid crystal composition 12
Color filter	Color filter 1	Color filter 2	Color filter 3	Color filter 4
VHR	99.3	99.5	99.8	99.7
ID	61	48	11	19
Image sticking	A	A	A	A

[Table 22]

	Example 49	Example 50	Example 51	Example 52
Liquid crystal composition	Liquid crystal composition 13	Liquid crystal composition 13	Liquid crystal composition 13	Liquid crystal composition 13
Color filter	Color filter 1	Color filter 2	Color filter 3	Color filter 4
VHR	99.2	99.4	99.6	99.7
ID	73	50	24	17
Image sticking	B	A	A	A

[Table 23]

	Example 53	Example 54	Example 55	Example 56
Liquid crystal composition	Liquid crystal composition 14	Liquid crystal composition 14	Liquid crystal composition 14	Liquid crystal composition 14
Color filter	Color filter 1	Color filter 2	Color filter 3	Color filter 4
VHR	99.4	99.5	99.8	99.8
ID	77	56	13	15
Image sticking	B	A	A	A

[0168] In the liquid crystal display devices of Examples 45 to 56, high VHRs and low IDs were achieved. In the evaluation of image sticking, no residual image was observed or a residual image was slightly observed, which was at an acceptable level.

(Examples 57 to 60)

[0169] A liquid crystal composition 15 was prepared by mixing 0.3% by mass of bismethacrylic acid biphenyl-4,4'-diyl with the liquid crystal composition 10 used in Example 37. The liquid crystal composition 15 was set in the TN cell. A polymerization treatment was performed by performing irradiation with ultraviolet rays (3.0 J/cm²) for 600 seconds while applying a driving voltage between electrodes. Liquid crystal display devices of Examples 57 to 60 were then produced using the color filters 1 to 4 listed in Table 2 and the VHR and ID were measured. The image sticking of the liquid crystal display devices was also evaluated. Table 24 shows the results.

[Table 24]

	Example 57	Example 58	Example 59	Example 60
--	------------	------------	------------	------------

EP 2 796 922 B1

(continued)

Liquid crystal composition	Liquid crystal composition 15	Liquid crystal composition 15	Liquid crystal composition 15	Liquid crystal composition 15
Color filter	Color filter 1	Color filter 2	Color filter 3	Color filter 4
VHR	99.4	99.5	99.7	99.7
ID	62	53	13	15
Image sticking	A	A	A	A

[0170] In the liquid crystal display devices of Examples 57 to 60, high VHRs and low IDs were achieved. In the evaluation of image sticking, no residual image was observed or a residual image was slightly observed, which was at an acceptable level.

(Examples 61 to 64)

[0171] A liquid crystal composition 16 was prepared by mixing 0.3% by mass of bismethacrylic acid biphenyl-4,4'-diyl with the liquid crystal composition 8 used in Example 29. The liquid crystal composition 16 was set in the IPS cell. A polymerization treatment was performed by performing irradiation with ultraviolet rays (3.0 J/cm²) for 600 seconds while applying a driving voltage between electrodes. Liquid crystal display devices of Examples 61 to 64 were then produced using the color filters 1 to 4 listed in Table 2 and the VHR and ID were measured. The image sticking of the liquid crystal display devices was also evaluated. Table 25 shows the results.

[Table 25]

	Example 61	Example 62	Example 63	Example 64
Liquid crystal composition	Liquid crystal composition 16	Liquid crystal composition 16	Liquid crystal composition 16	Liquid crystal composition 16
Color filter	Color filter 1	Color filter 2	Color filter 3	Color filter 4
VHR	99.2	99.4	99.7	99.6
ID	78	48	13	16
Image sticking	B	A	A	A

[0172] In the liquid crystal display devices of Examples 61 to 64, high VHRs and low IDs were achieved. In the evaluation of image sticking, no residual image was observed or a residual image was slightly observed, which was at an acceptable level.

(Examples 65 to 68)

[0173] A liquid crystal composition 17 was prepared by mixing 0.3% by mass of 3-fluorobiphenyl-4,4'-diyl with the liquid crystal composition 6 used in Example 21. The liquid crystal composition 17 was set in the FFS cell. A polymerization treatment was performed by performing irradiation with ultraviolet rays (3.0 J/cm²) for 600 seconds while applying a driving voltage between electrodes. Liquid crystal display devices of Examples 65 to 68 were then produced using the color filters 1 to 4 listed in Table 2 and the VHR and ID were measured. The image sticking of the liquid crystal display devices was also evaluated. Table 26 shows the results.

[Table 26]

	Example 65	Example 66	Example 67	Example 68
Liquid crystal composition	Liquid crystal composition 17	Liquid crystal composition 17	Liquid crystal composition 17	Liquid crystal composition 17
Color filter	Color filter 1	Color filter 2	Color filter 3	Color filter 4
VHR	99.4	99.5	99.7	99.6

(continued)

	Example 65	Example 66	Example 67	Example 68
Liquid crystal composition	Liquid crystal composition 17	Liquid crystal composition 17	Liquid crystal composition 17	Liquid crystal composition 17
ID	69	42	16	15
Image sticking	B	A	A	A

[0174] In the liquid crystal display devices of Examples 65 to 68, high VHRs and low IDs were achieved. In the evaluation of image sticking, no residual image was observed or a residual image was slightly observed, which was at an acceptable level.

(Comparative Examples 1 to 4)

[0175] A comparative liquid crystal composition 1 described below was set in the IPS cell used in Example 1. Table 27 shows the physical properties of the comparative liquid crystal composition. Liquid crystal display devices of Comparative Examples 1 to 4 were then produced using the color filters 1 to 4 listed in Table 2 and the VHR and ID were measured. The image sticking of the liquid crystal display devices was also evaluated. Table 28 shows the results.

Chemical structure	Proportion	Abbreviation
	27%	4-Cy-VO-Ph-1
	20%	5-Cy-VO-Ph-1
	20%	5-Cy-VO-Ph-3
	8%	3-Ph-Ph3-CFFO-Ph3-F
	13%	3-Cy-Cy-CFFO-Ph3-F
	12%	3-Ph-Ph1-Ph3-CFFO-Ph3-F

[Table 27]

$T_{NI}/^{\circ}\text{C}$	69.3
Δn	0.096
no	1.484
ε_{\perp}	5.5

(continued)

$\Delta\varepsilon$	4.8
$\eta/\text{mPa}\cdot\text{s}$	30.3

5

[Table 28]

	Comparative Example 1	Comparative Example 2	Comparative Example 3	Comparative Example 4
Liquid crystal composition	Comparative liquid crystal composition 1	Comparative liquid crystal composition 1	Comparative liquid crystal composition 1	Comparative liquid crystal composition 1
Color filter	Color filter 1	Color filter 2	Color filter 3	Color filter 4
VHR	98.1	98.3	98.6	98.5
ID	155	148	135	143
Image sticking	D	D	D	D

10

15

20

[0176] In the liquid crystal display devices of Comparative Examples 1 to 4, the VHRs were decreased and the IDs were increased compared with the liquid crystal display devices of the present invention. In the evaluation of image sticking, a residual image was observed, which was at an unacceptable level.

25

(Comparative Examples 5 to 12)

[0177] Comparative liquid crystal compositions 2 and 3 listed in Table 29 were sandwiched as in Example 1. Liquid crystal display devices of Comparative Examples 5 to 12 were produced using the color filters 1 to 4 listed in Table 2 and the VHR and ID were measured. The image sticking of the liquid crystal display devices was also evaluated. Tables 30 and 31 show the results.

30

[Table 29]

Comparative liquid crystal composition 2		Comparative liquid crystal composition 3	
Name of compound	Content (%)	Name of compound	Content (%)
2-Cy-Cy-Ph3-F	12	2-Cy-Cy-Ph3-F	12
3-Cy-Cy-Ph3-F	10	3-Cy-Cy-Ph3-F	10
5-Cy-Cy-Ph3-F	6	2-Cy-Cy-Ph-OCFFF	8
2-Cy-Cy-Ph-OCFFF	9	3-Cy-Cy-Ph-OCFFF	8
3-Cy-Cy-Ph-OCFFF	8	4-Cy-Cy-Ph-OCFFF	7
4-Cy-Cy-Ph-OCFFF	7	5-Cy-Cy-Ph-OCFFF	4
2-Cy-Ph1-Ph3-F	12	2-Cy-Ph1-Ph3-F	12
3-Cy-Ph1-Ph3-F	10	3-Cy-Ph1-Ph3-F	4
2-Cy-Py-Cy-CFFO-Ph3-F	5.5	2-Cy-Cy-CFFO-Ph3-F	12
2-Ph-Ph1-Ph3-F	5.5	2-Ph-Ph1-Ph3-F	8
0d1-Cy-Cy-CFFO-Ph3-F	15	0d1-Cy-Cy-CFFO-Ph3-F	15
$T_{ni}/^{\circ}\text{C}$	75.7	$T_{ni}/^{\circ}\text{C}$	75.0
$wj\Delta n$	0.093	Δn	0.093
$\gamma 1/\text{mPa}\cdot\text{s}$	146	$\gamma 1/\text{mPa}\cdot\text{s}$	139

50

55

EP 2 796 922 B1

[Table 30]

	Comparative Example 5	Comparative Example 6	Comparative Example 7	Comparative Example 8
Liquid crystal composition	Comparative liquid crystal composition 2	Comparative liquid crystal composition 2	Comparative liquid crystal composition 2	Comparative liquid crystal composition 2
Color filter	Color filter 1	Color filter 2	Color filter 3	Color filter 4
VHR	98.2	98.2	98.4	98.3
ID	151	147	127	140
Image sticking	D	D	C	D

[Table 31]

	Comparative Example 9	Comparative Example 10	Comparative Example 11	Comparative Example 12
Liquid crystal composition	Comparative liquid crystal composition 3	Comparative liquid crystal composition 3	Comparative liquid crystal composition 3	Comparative liquid crystal composition 3
Color filter	Color filter 1	Color filter 2	Color filter 3	Color filter 4
VHR	98.1	98.3	98.3	98.3
ID	158	154	114	121
Image sticking	D	D	C	D

[0178] In the liquid crystal display devices of Comparative Examples 5 to 12, the VHRs were decreased and the IDs were increased compared with the liquid crystal display devices of the present invention. In the evaluation of image sticking, a residual image was observed, which was at an unacceptable level.

(Comparative Examples 13 to 20)

[0179] Comparative liquid crystal compositions 4 and 5 listed in Table 32 were sandwiched as in Example 1. Liquid crystal display devices of Comparative Examples 13 to 24 were produced using the color filters 1 to 4 listed in Table 2 and the VHR and ID were measured. The image sticking of the liquid crystal display devices was also evaluated. Tables 33 and 34 show the results.

[Table 32]

Comparative liquid crystal composition 4		Comparative liquid crystal composition 5	
Name of compound	Content (%)	Name of compound	Content (%)
4-Cy-Cy-1d0	15	2-Cy-Cy-1d0	32
0d1-Cy-Cy-Ph-1	4	0d1-Cy-Cy-Ph-1	4
0d3-Cy-Cy-Ph-1	14	2-Ph-Ph1-Ph-3	10
3-Cy-Ph-Ph-Cy-3	3	2-Ph-Ph1-Ph-5	11
3-Cy-Ph-Ph1-Cy-3	4	3-Ph-Ph1-Ph-5	7
1-Cy-Cy-Ph3-F	9	2-Cy-Cy-Ph-F	6
2-Cy-Cy-Ph3-F	10	3-Cy-Cy-Ph-F	21
3-Cy-Cy-Ph3-F	10	5-Cy-Ph-Ph-F	7
5-Cy-Cy-Ph3-F	5	3-Cy-Ph-Ph3-F	2

EP 2 796 922 B1

(continued)

Comparative liquid crystal composition 4		Comparative liquid crystal composition 5	
Name of compound	Content (%)	Name of compound	Content (%)
3-Cy-Ph1-Ph3-F	8	$T_{ni}/^{\circ}\text{C}$	77.2
5-Cy-Ph1-Ph3-F	7	Δn	0.135
3-Ph-Ph1-Ph3-F	3	$\Delta \epsilon$	4.5
3-Cy-Cy-Ph1-Ph3-F	8	$\gamma 1/\text{mPa}\cdot\text{s}$	57
$T_{ni}/^{\circ}\text{C}$	101.0	$\eta/\text{mPa}\cdot\text{s}$	10.5
Δn	0.095		
$\Delta \epsilon$	8.2		
$\gamma 1/\text{mPa}\cdot\text{s}$	115		
$\eta/\text{mPa}\cdot\text{s}$	23.6		

[Table 33]

	Comparative Example 13	Comparative Example 14	Comparative Example 15	Comparative Example 16
Liquid crystal composition	Comparative liquid crystal composition 4	Comparative liquid crystal composition 4	Comparative liquid crystal composition 4	Comparative liquid crystal composition 4
Color filter	Color filter 1	Color filter 2	Color filter 3	Color filter 4
VHR	98.1	98.1	98.2	98.4
ID	169	136	150	142
Image sticking	D	D	D	D

[Table 34]

	Comparative Example 17	Comparative Example 18	Comparative Example 19	Comparative Example 20
Liquid crystal composition	Comparative liquid crystal composition 5	Comparative liquid crystal composition 5	Comparative liquid crystal composition 5	Comparative liquid crystal composition 5
Color filter	Color filter 1	Color filter 2	Color filter 3	Color filter 4
VHR	98.1	98.1	98.3	98.4
ID	184	177	126	130
Image sticking	D	D	C	C

[0180] In the liquid crystal display devices of Comparative Examples 13 to 20, the VHRs were decreased and the IDs were increased compared with the liquid crystal display devices of the present invention. In the evaluation of image sticking, a residual image was observed, which was at an unacceptable level.

(Comparative Examples 21 to 32)

[0181] Comparative liquid crystal compositions 6 to 8 listed in Table 35 were sandwiched as in Example 1. Liquid crystal display devices of Comparative Examples 21 to 32 were produced using the color filters 1 to 4 listed in Table 2

EP 2 796 922 B1

and the VHR and ID were measured. The image sticking of the liquid crystal display devices was also evaluated. Tables 36 to 38 show the results.

[Table 35]

Comparative liquid crystal composition 6		Comparative liquid crystal composition 7		Comparative liquid crystal composition 8	
Name of compound	Content (%)	Name of compound	Content (%)	Name of compound	Content (%)
4-Cy-Cy-1d0	18	4-Cy-Cy-1d0	18	4-Cy-Cy-1d0	17
3-Cy-Cy-4	15	3-Cy-Cy-4	15	3-Cy-Cy-4	15
0d1-Cy-Cy-Ph-1	8	0d1-Cy-Cy-Ph-1	8	0d3-Cy-Cy-Ph-1	8
2-Ph-Ph1-Ph-3	10	2-Ph-Ph1-Ph-3	10	3-Cy-Ph-Ph-2	10
2-Ph-Ph1-Ph-5	6	2-Ph-Ph1-Ph-5	6	2-Ph-Ph1-Ph-5	7
3-Ph-Ph1-Ph-5	6	3-Ph-Ph1-Ph-5	5	3-Ph-Ph1-Ph-5	7
2-Cy-Cy-Ph-F	6	2-Cy-Cy-Ph-F	6	2-Cy-Cy-Ph-F	6
3-Cy-Cy-Ph-F	10	3-Cy-Cy-Ph-F	5	3-Cy-Cy-Ph-F	5
5-Cy-Ph-Ph-F	7	5-Cy-Ph-Ph-F	7	5-Cy-Ph-Ph-F	7
3-Cy-Ph-Ph3-F	14	3-Cy-Ph-Ph3-F	15	3-Cy-Ph-Ph3-F	14
$T_{ni}/^{\circ}\text{C}$	73.5	3-Cy-Cy-Ph1-Ph3-F	5	3-Cy-Cy-Ph1-Ph3-F	4
Δn	0.126	$T_{ni}/^{\circ}\text{C}$	75.7	$T_{ni}/^{\circ}\text{C}$	85.3
$\Delta\varepsilon$	4.9	Δn	0.125	Δn	0.128
$\gamma 1/\text{mPa}\cdot\text{s}$	94	$\Delta\varepsilon$	5.5	$\Delta\varepsilon$	4.8
$\eta/\text{mPa}\cdot\text{s}$	16.9	$\gamma 1/\text{mPa}\cdot\text{s}$	103	$\gamma 1/\text{mPa}\cdot\text{s}$	107
		$\eta/\text{mPa}\cdot\text{s}$	18.4	$\eta/\text{mPa}\cdot\text{s}$	19.0

[Table 36]

	Comparative Example 21	Comparative Example 22	Comparative Example 23	Comparative Example 24
Liquid crystal composition	Comparative liquid crystal composition 6	Comparative liquid crystal composition 6	Comparative liquid crystal composition 6	Comparative liquid crystal composition 6
Color filter	Color filter 1	Color filter 2	Color filter 3	Color filter 4
VHR	98.1	98.2	98.3	98.4
ID	178	167	143	134
Image sticking	D	D	D	C

[Table 37]

	Comparative Example 25	Comparative Example 26	Comparative Example 27	Comparative Example 28
Liquid crystal composition	Comparative liquid crystal composition 7	Comparative liquid crystal composition 7	Comparative liquid crystal composition 7	Comparative liquid crystal composition 7
Color filter	Color filter 1	Color filter 2	Color filter 3	Color filter 4
VHR	98.2	98.2	98.4	98.4
ID	156	150	125	122

EP 2 796 922 B1

(continued)

	Comparative Example 25	Comparative Example 26	Comparative Example 27	Comparative Example 28
5	Liquid crystal composition	Comparative liquid crystal composition 7	Comparative liquid crystal composition 7	Comparative liquid crystal composition 7
10	Image sticking	D	C	D

[Table 38]

	Comparative Example 29	Comparative Example 30	Comparative Example 31	Comparative Example 32
15	Liquid crystal composition	Comparative liquid crystal composition 8	Comparative liquid crystal composition 8	Comparative liquid crystal composition 8
20	Color filter	Color filter 1	Color filter 3	Color filter 4
	VHR	98.1	98.3	98.4
	ID	177	129	119
25	Image sticking	D	D	D

[0182] In the liquid crystal display devices of Comparative Examples 21 to 32, the VHRs were decreased and the IDs were increased compared with the liquid crystal display devices of the present invention. In the evaluation of image sticking, a residual image was observed, which was at an unacceptable level.

(Comparative Examples 33 to 44)

[0183] Comparative liquid crystal compositions 9 to 11 listed in Table 39 were sandwiched as in Example 1. Liquid crystal display devices of Comparative Examples 33 to 44 were produced using the color filters 1 to 4 listed in Table 2 and the VHR and ID were measured. The image sticking of the liquid crystal display devices was also evaluated. Tables 40 to 42 show the results.

[Table 40]

	Comparative Example 33	Comparative Example 34	Comparative Example 35	Comparative Example 36
Liquid crystal composition	Comparative liquid crystal composition 9	Comparative liquid crystal composition 9	Comparative liquid crystal composition 9	Comparative liquid crystal composition 9
Color filter	Color filter 1	Color filter 2	Color filter 3	Color filter 4
VHR	98.1	98.3	98.5	98.4
ID	162	139	123	134
Image sticking	D	D	D	D

[Table 41]

	Comparative Example 37	Comparative Example 38	Comparative Example 39	Comparative Example 40
Liquid crystal composition	Comparative liquid crystal composition 10	Comparative liquid crystal composition 10	Comparative liquid crystal composition 10	Comparative liquid crystal composition 10
Color filter	Color filter 1	Color filter 2	Color filter 3	Color filter 4
VHR	98.2	98.3	98.5	98.5
ID	153	138	129	116
Image sticking	D	D	C	C

[Table 42]

	Comparative Example 41	Comparative Example 42	Comparative Example 43	Comparative Example 44
Liquid crystal composition	Comparative liquid crystal composition 11	Comparative liquid crystal composition 11	Comparative liquid crystal composition 11	Comparative liquid crystal composition 11
Color filter	Color filter 1	Color filter 2	Color filter 3	Color filter 4
VHR	98.3	98.3	98.4	98.4
ID	152	144	118	131
Image sticking	D	D	D	D

[0184] In the liquid crystal display devices of Comparative Examples 33 to 44, the VHRs were decreased and the IDs were increased compared with the liquid crystal display devices of the present invention. In the evaluation of image sticking, a residual image was observed, which was at an unacceptable level.

(Comparative Examples 45 to 52)

[0185] Liquid crystal display devices of Comparative Examples 45 to 52 were produced in the same manner, except that the comparative color filter 1 listed in Table 2 was used instead of the color filter 1 in Examples 5, 13, 17, 25, 37, 45, 61, and 65. The VHR and ID were measured. The image sticking of the liquid crystal display devices was also

evaluated. Tables 43 to 44 show the results.

[Table 43]

	Comparative Example 45	Comparative Example 46	Comparative Example 47	Comparative Example 48
Liquid crystal composition	Liquid crystal composition 2	Liquid crystal composition 4	Liquid crystal composition 5	Liquid crystal composition 7
Color filter	Comparative color filter 1	Comparative color filter 1	Comparative color filter 1	Comparative color filter 1
VHR	97.9	98.0	98.3	98.3
ID	206	202	175	164
Image sticking	D	D	D	D

[Table 44]

	Comparative Example 49	Comparative Example 50	Comparative Example 51	Comparative Example 52
Liquid crystal composition	Liquid crystal composition 10	Liquid crystal composition 12	Liquid crystal composition 16	Liquid crystal composition 17
Color filter	Comparative color filter 1	Comparative color filter 1	Comparative color filter 1	Comparative color filter 1
VHR	97.8	98.0	98.4	98.3
ID	211	193	158	167
Image sticking	D	D	D	D

[0186] In the liquid crystal display devices of Comparative Examples 45 to 52, the VHRs were decreased and the IDs were increased compared with the liquid crystal display devices of the present invention. In the evaluation of image sticking, a residual image was observed, which was at an unacceptable level.

Claims

1. A liquid crystal display device comprising a first substrate, a second substrate, a liquid crystal composition layer sandwiched between the first substrate and the second substrate, a color filter constituted by a black matrix and at least RGB three color pixel portions, a pixel electrode, and a common electrode, wherein the liquid crystal composition layer contains a liquid crystal composition containing at least one compound represented by general formula (I),

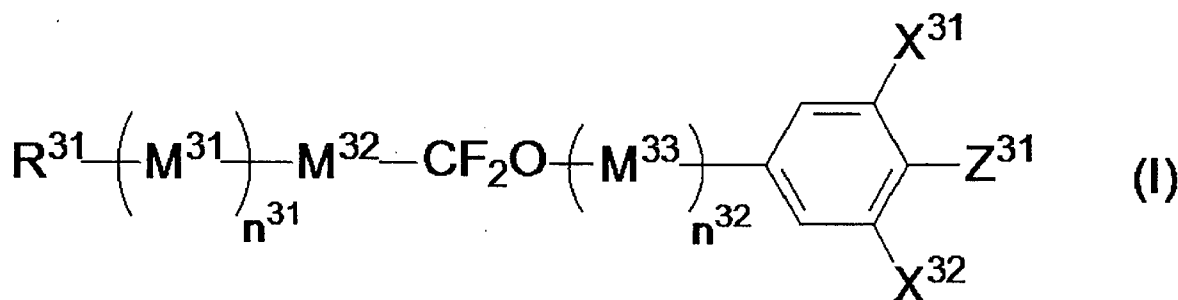

in general formula, R^{31} represents an alkyl group or alkoxy group having 1 to 10 carbon atoms or an alkenyl group or alkenyloxy group having 2 to 10 carbon atoms, M^{31} to M^{33} each independently represent a trans-1,4-cyclohexylene

group or a 1,4-phenylene group, one or two -CH₂- in the trans-1,4-cyclohexylene group may be substituted with -O- unless oxygen atoms directly bond to each other, one or two hydrogen atoms in the phenylene group may be substituted with a fluorine atom, X³¹ and X³² each independently represent a hydrogen atom or a fluorine atom, Z³¹ represents a fluorine atom, a trifluoromethoxy group, or a trifluoromethyl group, n³¹ and n³² each independently represent 0, 1, or 2, n³¹ + n³² represents 0, 1, or 2, and when a plurality of M³¹ or M³³ are present, the plurality of M³¹ may be the same or different or the plurality of M³³ may be the same or different, and at least one compound selected from the group consisting of compounds represented by general formula (II-a) to general formula (II-e),

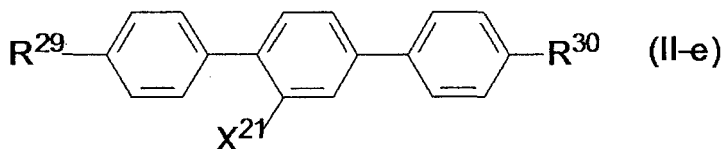
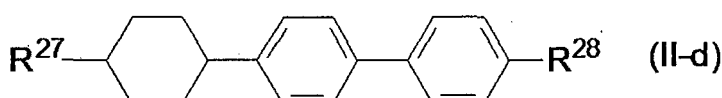
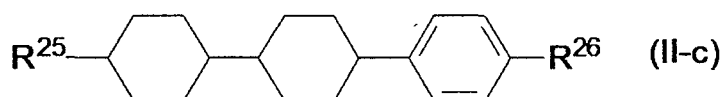
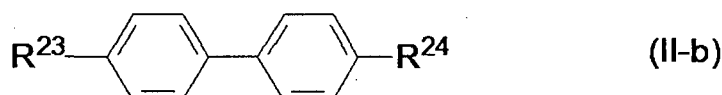
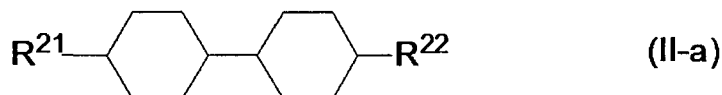

35 in general formulae, R²¹ to R³⁰ each independently represent an alkyl group having 1 to 10 carbon atoms or an alkenyl group having 2 to 10 carbon atoms, and X²¹ represents a hydrogen atom or a fluorine atom; the RGB three color pixel portions contain, in a G pixel portion as a coloring material, a halogenated metal phthalocyanine pigment having a central metal selected from the group consisting of Al, Si, Sc, Ti, V, Mg, Fe, Co, Ni, Zn, Ga, Ge, Y, Zr, Nb, In, Sn, and Pb; when the central metal is a trivalent metal, any one of a halogen atom, a hydroxyl group, and a sulfonic acid group bonds to the central metal or the central metal forms an oxo-bridge or thio-bridge; and, when the central metal is a tetravalent metal, a single oxygen atom or any two of a halogen atom, a hydroxyl group, and a sulfonic acid group which may be the same or different bond to the central metal.

- 45
2. The liquid crystal display device according to Claim 1, wherein the RGB three color pixel portions contain, as coloring materials, a diketopyrrolopyrrole pigment and/or an anionic red organic dye in an R pixel portion and an ε-type copper phthalocyanine pigment and/or a cationic blue organic dye in a B pixel portion.
 3. The liquid crystal display device according to Claim 1 or 2, wherein the RGB three color pixel portions contain, as coloring materials, C.I. Solvent Red 124 in an R pixel portion and C.I. Solvent Blue 7 in a B pixel portion.

50

 4. The liquid crystal display device according to Claim 1 or 2, wherein the RGB three color pixel portions contain, as coloring materials, C.I. Pigment Red 254 in an R pixel portion and C.I. Pigment Blue 15:6 in a B pixel portion.

55

 5. The liquid crystal display device according to any one of Claims 1 to 4, wherein the G pixel portion contains a halogenated zinc phthalocyanine pigment which includes Zn as the central metal and in which 8 to 16 halogen atoms per molecule of phthalocyanine bond to benzene rings of a phthalocyanine molecule.
 6. The liquid crystal display device according to any one of Claims 1 to 5, wherein the G pixel portion contains C.I.

Pigment Green 58.

7. The liquid crystal display device according to any one of Claims 1 to 6, wherein the G pixel portion further contains at least one organic dye/pigment selected from the group consisting of C.I. Pigment Yellow 150, 215, 185, and 138 and C.I. Solvent Yellow 21, 82, 83:1, and 33.
8. The liquid crystal display device according to any one of Claims 1 to 7, wherein the color filter is constituted by the black matrix, the RGB three color pixel portions, and a Y pixel portion, and the Y pixel portion contains, as a coloring material, at least one yellow organic dye/pigment selected from the group consisting of C.I. Pigment Yellow 150, 215, 185, 138, and 139 and C.I. Solvent Yellow 21, 82, 83:1, 33, and 162.
9. The liquid crystal display device according to any one of Claims 1 to 8, wherein the compound represented by general formula (I) includes compounds represented by general formula (I-a) to general formula (I-f),

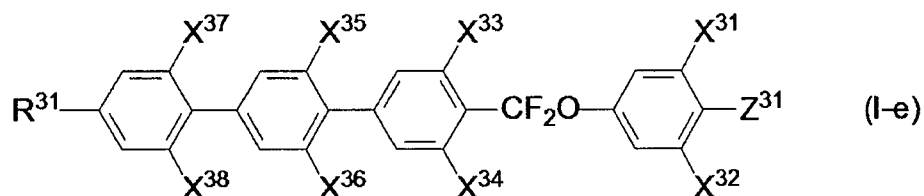
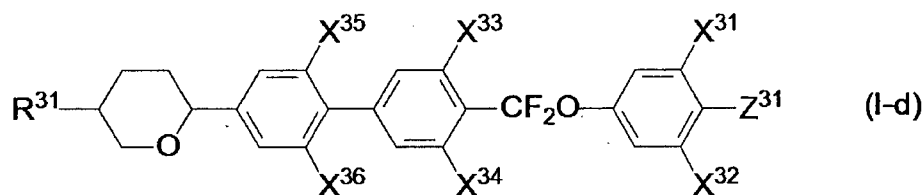
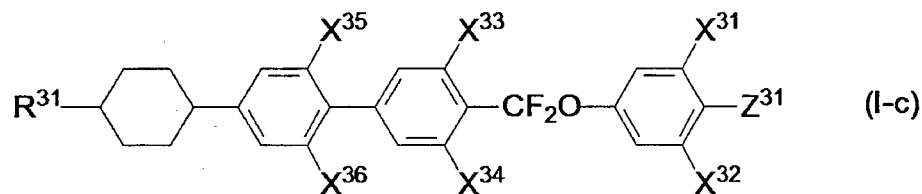
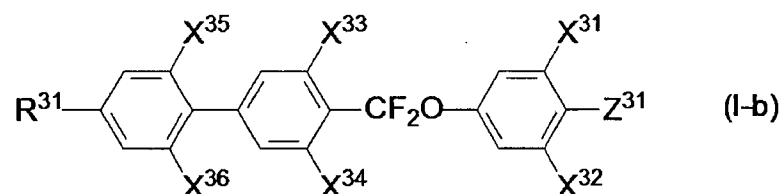
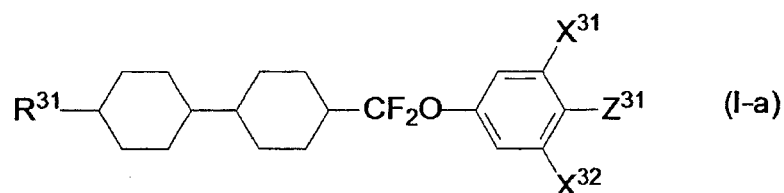

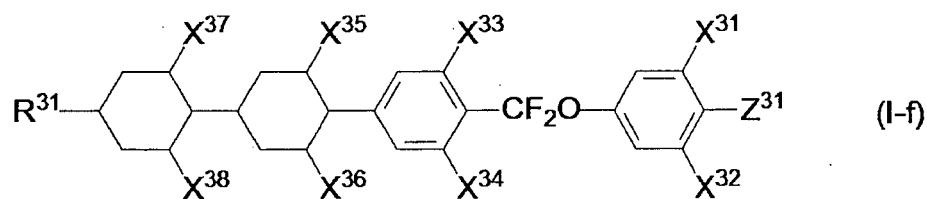

10 in general formulae, R^{31} represents an alkyl group or alkoxy group having 1 to 10 carbon atoms or an alkenyl group or alkenyloxy group having 2 to 10 carbon atoms, X^{31} to X^{38} each independently represent a hydrogen atom or a fluorine atom, and Z^{31} represents a fluorine atom, a trifluoromethoxy group, or a trifluoromethyl group.

- 15 **10.** The liquid crystal display device according to any one of Claims 1 to 9, wherein the liquid crystal composition layer further contains at least one compound selected from the group consisting of compounds represented by general formula (III-a) to general formula (III-f),

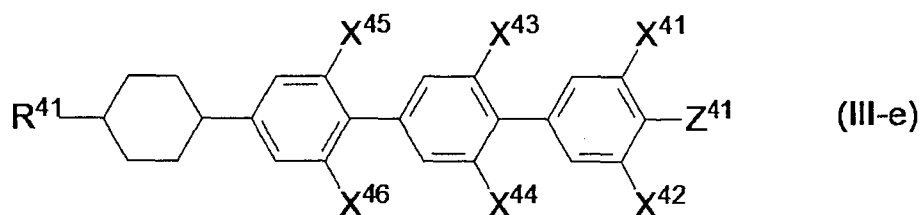
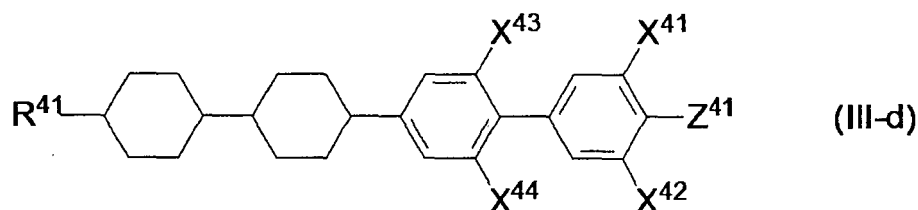
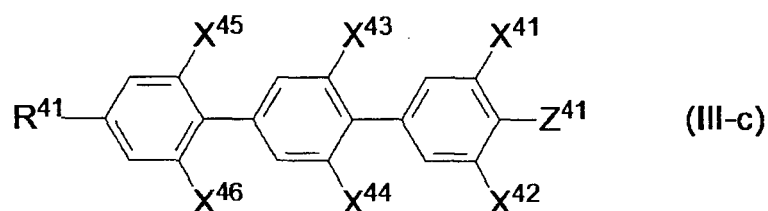
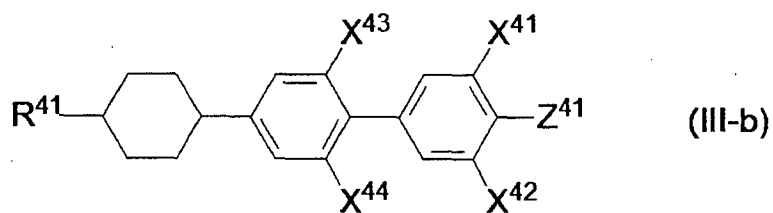
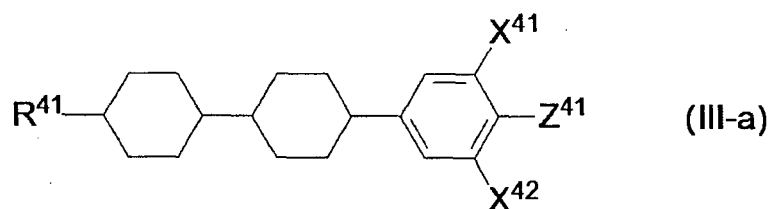

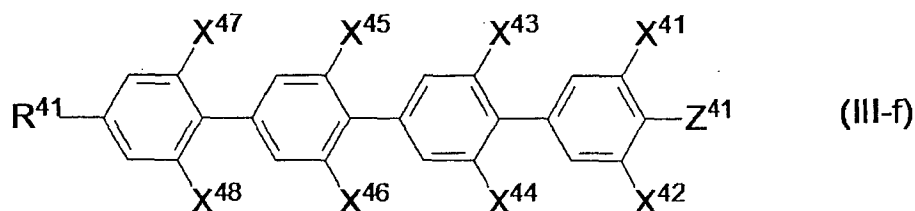

10 in general formulae, R^{41} represents an alkyl group or alkoxy group having 1 to 10 carbon atoms or an alkenyl group or alkenyloxy group having 2 to 10 carbon atoms, X^{41} to X^{48} each independently represent a hydrogen atom or a fluorine atom, and Z^{41} represents a fluorine atom, a trifluoromethoxy group, or a trifluoromethyl group.

- 15
11. The liquid crystal display device according to any one of Claims 1 to 10, wherein the liquid crystal composition layer contains a polymer obtained by polymerizing a liquid crystal composition containing at least one polymerizable compound.
- 20
12. The liquid crystal display device according to any one of Claims 1 to 11, wherein the liquid crystal composition layer contains a bifunctional monomer represented by general formula (V),

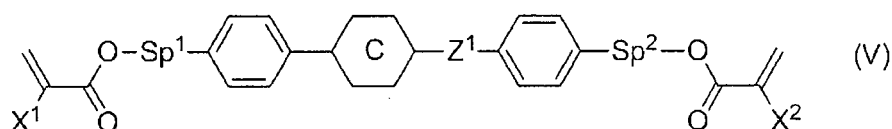

30 in general formula, X^1 and X^2 each independently represent a hydrogen atom or a methyl group; Sp^1 and Sp^2 each independently represent a single bond, an alkylene group having 1 to 8 carbon atoms, or $-O-(CH_2)_s-$, where s represents an integer of 2 to 7 and the oxygen atom bonds to an aromatic ring; Z^1 represents $-OCH_2-$, $-CH_2O-$, $-COO-$, $-OCO-$, $-CF_2O-$, $-OCF_2-$, $-CH_2CH_2-$, $-CF_2CF_2-$, $-CH=CH-COO-$, $-CH=CH-OCO-$, $-COO-CH=CH-$, $-OCO-CH=CH-$, $-COO-CH_2CH_2-$, $-OCO-CH_2CH_2-$, $-CH_2CH_2-COO-$, $-CH_2CH_2-OCO-$, $-COO-CH_2-$, $-OCO-CH_2-$, $-CH_2-COO-$, $-CH_2-OCO-$, $-CY^1=CY^2-$, where Y^1 and Y^2 each independently represent a fluorine atom or a hydrogen atom, $-C\equiv C-$, or a single bond; and C represents a 1,4-phenylene group, a trans-1,4-cyclohexylene group, or a single bond and, in all the 1,4-phenylene groups in general formula, any of hydrogen atoms may be substituted with fluorine atoms.

35

Patentansprüche

- 40
1. Flüssigkristallanzeigevorrichtung, welche ein erstes Substrat, ein zweites Substrat, eine Flüssigkristallzusammensetzungsschicht, die zwischen dem ersten Substrat und dem zweiten Substrat gehalten wird, einen Farbfilter, der aus einer Black Matrix und mindestens RGB-Dreifarben-Pixelbereichen besteht, eine Pixelelektrode und eine gemeinsame Elektrode, umfasst,
- 45 wobei die Flüssigkristallzusammensetzungsschicht eine Flüssigkristallzusammensetzung beinhaltet, welche mindestens eine Verbindung, dargestellt durch allgemeine Formel (I),

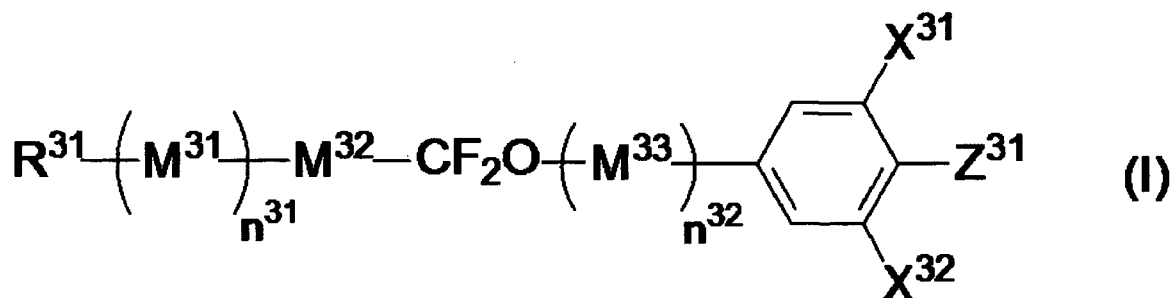

wobei in allgemeiner Formel R^{31} eine Alkylgruppe oder Alkoxygruppe mit 1 bis 10 Kohlenstoffatomen oder eine Alkenylgruppe oder Alkenyloxygruppe mit 2 bis 10 Kohlenstoffatomen darstellt, M^{31} bis M^{33} jeweils unabhängig

eine trans-1,4-Cyclohexylengruppe oder eine 1,4-Phenylengruppe darstellen, wobei ein oder zwei -CH₂- in der trans-1,4-Cyclohexylengruppe durch -O- ersetzt sein können, sofern Sauerstoffatome nicht direkt aneinander gebunden sind, ein oder zwei Wasserstoffatome in der Phenylengruppe durch ein Fluoratom ersetzt sein können, X³¹ und X³² jeweils unabhängig ein Wasserstoffatom oder ein Fluoratom darstellen, Z³¹ ein Fluoratom, eine Trifluor-methoxygruppe oder eine Trifluormethylgruppe darstellt, n³¹ und n³² jeweils unabhängig 0, 1 oder 2 darstellen, n³¹ + n³² 0, 1 oder 2 darstellt und wenn eine Vielzahl von M³¹ oder M³³ vorhanden sind, die Vielzahl von M³¹ die gleichen oder verschieden sein kann oder die Vielzahl von M³³ die gleiche oder verschieden sein kann, und mindestens eine Verbindung, ausgewählt aus der Gruppe, bestehend aus Verbindungen, dargestellt durch allgemeine Formel (II-a) bis allgemeine Formel (II-e), beinhaltet,

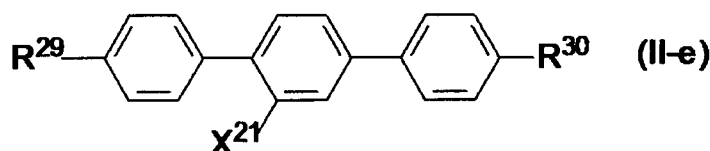
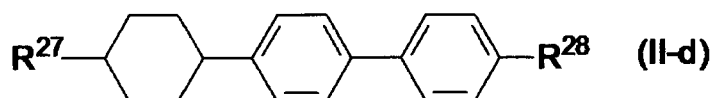
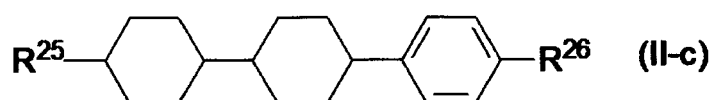
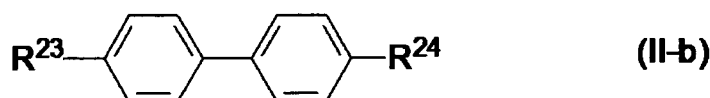
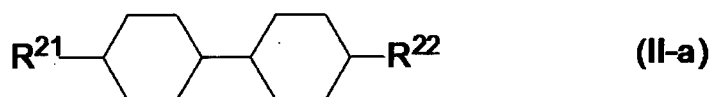

wobei in allgemeinen Formeln R²¹ bis R³⁰ jeweils unabhängig eine Alkylgruppe mit 1 bis 10 Kohlenstoffatomen oder eine Alkenylgruppe mit 2 bis 10 Kohlenstoffatomen darstellen und X²¹ ein Wasserstoffatom oder ein Fluoratom darstellt;

40 wobei die RGB-Dreifarben-Pixelbereiche in einem G-Pixelbereich als ein Färbematerial ein halogeniertes Metallphthalocyaninpigment beinhalten, welches ein zentrales Metall, ausgewählt aus der Gruppe, bestehend aus Al, Si, Sc, Ti, V, Mg, Fe, Co, Ni, Zn, Ga, Ge, Y, Zr, Nb, In, Sn und Pb, hat; wobei, wenn das zentrale Metall trivalent ist, bindet irgendeines von einem Halogenatom, einer Hydroxylgruppe und einer Sulfonsäuregruppe an das zentrale Metall oder das zentrale Metall bildet eine Oxobrücke oder Thiobrücke; und wenn das zentrale Metall ein tetravalentes Metall ist, binden ein einzelnes Sauerstoffatom oder zwei beliebige von einem Halogenatom, einer Hydroxylgruppe und einer Sulfonsäuregruppe, welche die gleichen oder verschieden sind, an das zentrale Metall.

- 50
2. Flüssigkristallanzeigergerät gemäß Anspruch 1, wobei die RGB-Dreifarben-Pixelbereiche als Färbematerialien ein Diketopyrrolopyrrolpigment und/oder einen anionischen roten organischen Farbstoff in einem R-Pixelbereich und ein Kupferphthalocyaninpigment vom ε-Typ und/oder einen kationischen blauen organischen Farbstoff in einem B-Pixelbereich enthalten.
 3. Flüssigkristallanzeigergerät gemäß Anspruch 1 oder 2, wobei die RGB-Dreifarben-Pixelbereiche als Färbematerialien C. I. Solvent Red 124 in einem R-Pixelbereich und C. I. Solvent Blue 7 in einem B-Pixelbereich, beinhalten.
 - 55 4. Flüssigkristallanzeigergerät gemäß Anspruch 1 oder 2, wobei die RGB-Dreifarben-Pixelbereiche als Färbematerialien C. I. Pigment Red 254 in einem R-Pixelbereich und C. I. Pigment Blue 15:6 in einem B-Pixelbereich beinhalten.

5. Flüssigkristallanzeigergerät gemäß einem der Ansprüche 1 bis 4, wobei der G-Pixelbereich ein halogeniertes Zinkphthalocyaninpigment beinhaltet, welches Zink als ein zentrales Metall einschließt und in welchem 8 bis 16 Halogenatome pro Molekül eines Phthalocyanins an Benzolringe eines Phthalocyaninmoleküls gebunden sind.

6. Flüssigkristallanzeigergerät gemäß einem der Ansprüche 1 bis 5, wobei der G-Pixelbereich C. I. Pigment Green 58 beinhaltet.

7. Flüssigkristallanzeigergerät gemäß einem der Ansprüche 1 bis 6, wobei der G-Pixelbereich zusätzlich mindestens einen organischen Farbstoff/ein organisches Pigment, ausgewählt aus der Gruppe, bestehend aus C. I. Pigment Yellow 150, 215, 185 und 138 und C. I. Solvent Yellow 21, 82, 83:1 und 33 beinhaltet.

8. Flüssigkristallanzeigergerät gemäß einem der Ansprüche 1 bis 7, wobei der Farbfilter durch die Black Matrix, die RGB-Dreifarben-Pixelbereiche und einen Y-Pixelbereich gebildet ist und der Y-Pixelbereich als ein Färbematerial mindestens einen gelben organischen Farbstoff/ein gelbes organisches Pigment, ausgewählt aus der Gruppe, bestehend aus C. I. Pigment Yellow 150, 215, 185, 138 und 139 und C. I. Solvent Yellow 21, 82, 83:1, 33 und 162 beinhaltet.

9. Flüssigkristallanzeigergerät gemäß einem der Ansprüche 1 bis 8, wobei die Verbindung, dargestellt durch allgemeine Formel (I) Verbindungen, dargestellt durch allgemeine Formel (I-a) bis allgemeine Formel (I-f), einschließt,

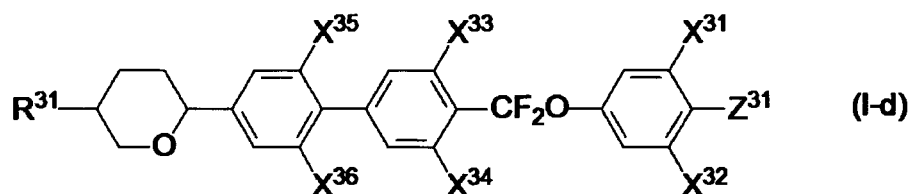
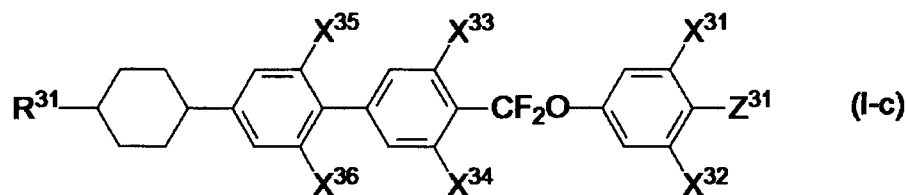
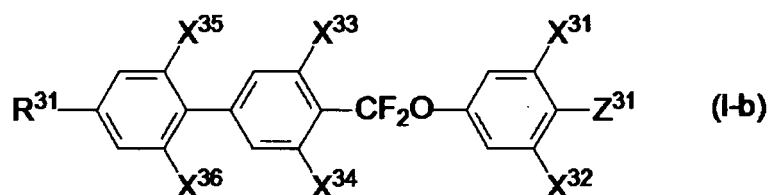
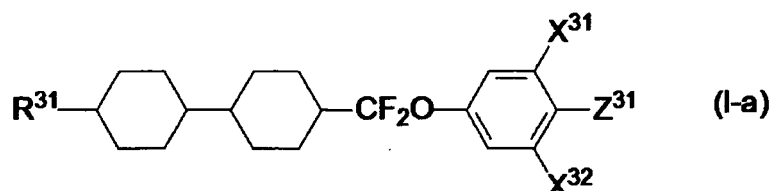

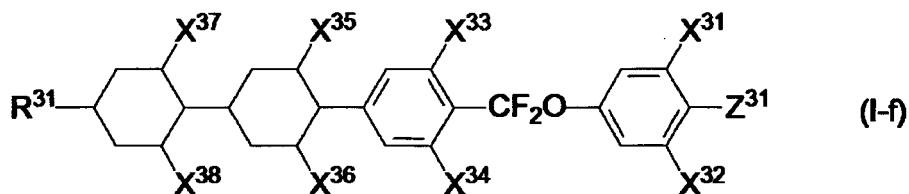
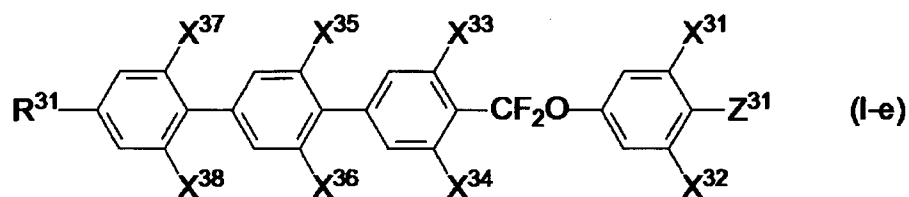

wobei in allgemeinen Formeln R³¹ eine Alkylgruppe oder Alkoxygruppe mit 1 bis 10 Kohlenstoffatomen oder eine Alkenylgruppe oder Alkenyloxygruppe mit 2 bis 10 Kohlenstoffatomen darstellt, X³¹ bis X³⁸ jeweils unabhängig ein Wasserstoffatom oder ein Fluoratom darstellen und Z³¹ ein Fluoratom, eine Trifluormethoxygruppe oder eine Trifluormethylgruppe darstellt.

20

10. Flüssigkristallanzeigergerät gemäß einem der Ansprüche 1 bis 9, wobei die Flüssigkristallzusammensetzungsschicht zusätzlich mindestens eine Verbindung, ausgewählt aus der Gruppe, bestehend aus Verbindungen, dargestellt durch allgemeine Formel (III-a) bis allgemeine Formel (III-f), beinhaltet,
- 25

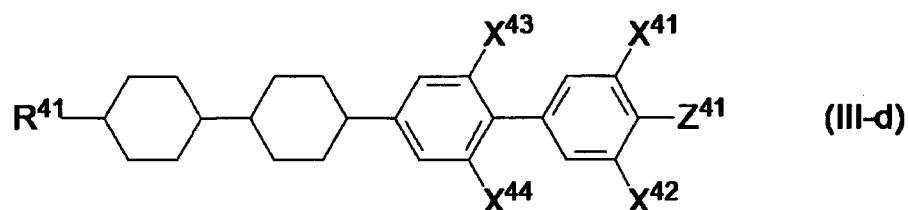
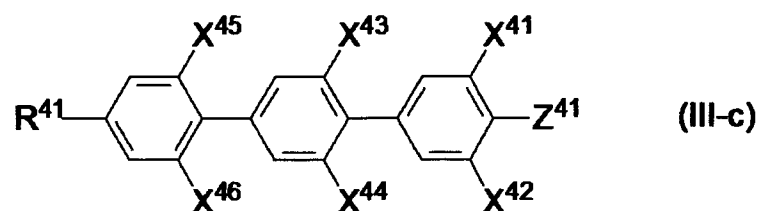
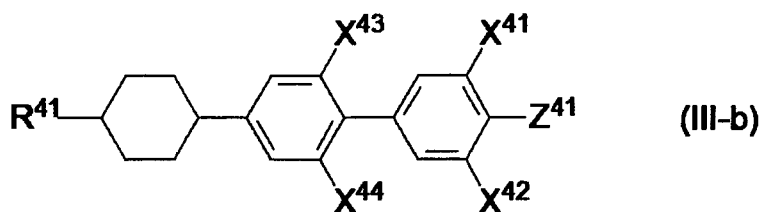
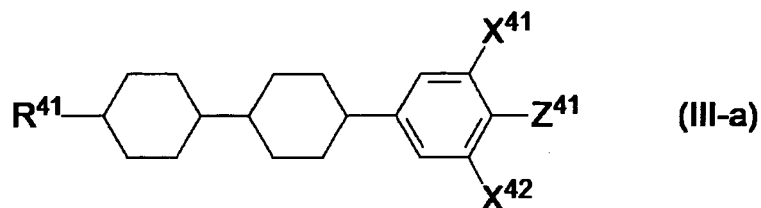

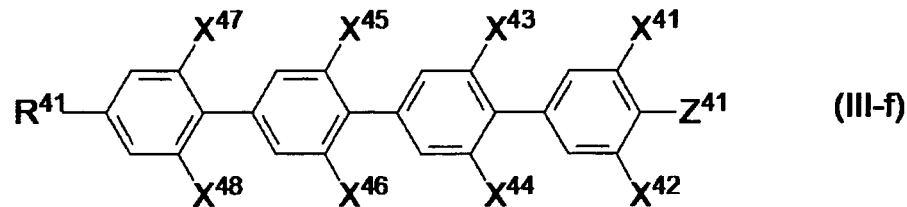
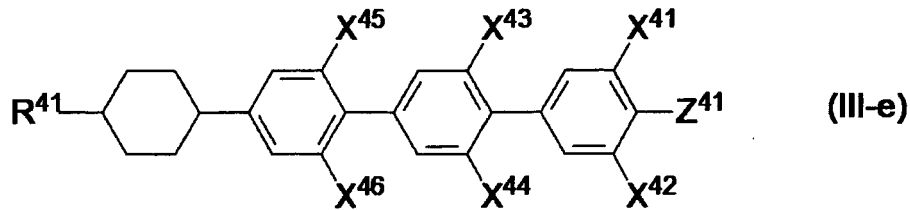

20
wobei in allgemeinen Formeln R⁴¹ eine Alkylgruppe oder Alkoxygruppe mit 1 bis 10 Kohlenstoffatomen oder eine Alkenylgruppe oder Alkenyloxygruppe mit 2 bis 10 Kohlenstoffatomen darstellt, X⁴¹ bis X⁴⁸ jeweils unabhängig ein Wasserstoffatom oder ein Fluoratom darstellen und Z⁴¹ ein Fluoratom, eine Trifluormethoxygruppe oder eine Trifluormethylgruppe darstellt.

- 25
11. Flüssigkristallanzeigergerät gemäß einem der Ansprüche 1 bis 10, wobei die Flüssigkristallzusammensetzungsschicht ein Polymer beinhaltet, das durch Polymerisierung einer Flüssigkristallzusammensetzung, die mindestens eine polymerisierbare Verbindung beinhaltet, erhalten wird.
- 30
12. Flüssigkristallanzeigergerät gemäß einem der Ansprüche 1 bis 11, wobei die Flüssigkristallzusammensetzungsschicht ein bifunktionelles Monomer, dargestellt durch allgemeine Formel (V), beinhaltet,

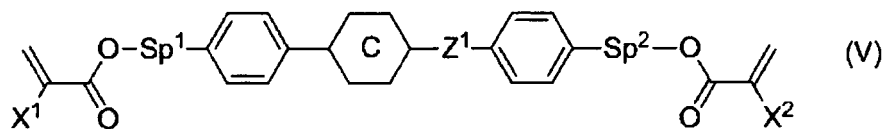

40
wobei in allgemeiner Formel X¹ und X² jeweils unabhängig ein Wasserstoffatom oder eine Methylgruppe darstellen; Sp¹ und Sp² jeweils unabhängig eine Einzelbindung, eine Alkylengruppe mit 1 bis 8 Kohlenstoffatomen oder -O-(CH₂)_s-, wobei s eine ganze Zahl von 2 bis 7 darstellt und das Sauerstoffatom an einen aromatischen Ring gebunden ist, darstellen; Z¹ -OCH₂-, -CH₂O-, -COO-, -OCO-, -CF₂O-, -OCF₂-, -CH₂CH₂-, -CF₂CF₂-, -CH=CH-COO-, -CH=CH-OCO-, -COO-CH=CH-, -OCO-CH=CH-, -COO-CH₂CH₂-, -OCO-CH₂CH₂-, -CH₂CH₂-COO-, -CH₂CH₂-OCO-, -COO-CH₂-, -OCO-CH₂-, -CH₂-COO-, -CH₂-OCO-, -CY¹=CY²-, wobei Y¹ und Y² jeweils unabhängig ein Fluoratom oder ein Wasserstoffatom darstellen, -C≡C- oder eine Einzelbindung darstellt; und C eine 1,4-Phenylengruppe, eine trans-1,4-Cyclohexylengruppe oder eine Einzelbindung darstellt und in allen der 1,4-Phenylengruppen in der allgemeinen Formel beliebige der Wasserstoffatome durch Fluoratome ersetzt sein können.

45

Revendications

- 50
1. Dispositif d'affichage à cristaux liquides comprenant un premier substrat, un second substrat, une couche à composition de cristaux liquides intercalée entre le premier substrat et le second substrat, un filtre coloré constitué d'une matrice noire et de parties de pixel contenant au moins les trois couleurs RVB, une électrode de pixel et une électrode de référence,
- 55
dans lequel la couche à composition de cristaux liquides contient une composition de cristaux liquides contenant au moins un composé représenté par la formule générale (I),

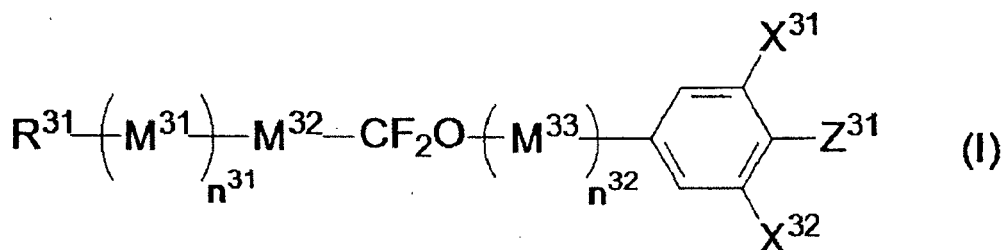

dans la formule générale, R^{31} représente un groupe alkyle ou un groupe alcoxy comportant de 1 à 10 atomes de carbone ou un groupe alcényle ou un groupe alcényloxy comportant de 2 à 10 atomes de carbone, M^{31} à M^{33} représentent chacun indépendamment un groupe trans-1,4-cyclohexylène ou un groupe 1,4-phénylène, un ou deux groupes $-CH_2-$ du groupe trans-1,4-cyclohexylène peu(ven)t être substitué(s) par un groupe $-O-$ sauf si les atomes d'oxygène sont directement liés l'un à l'autre, un ou deux atomes d'hydrogène du groupe phénylène peu(ven)t être substitué(s) par un atome de fluor, X^{31} et X^{32} représentent chacun indépendamment un atome d'hydrogène ou un atome de fluor, Z^{31} représente un atome de fluor, un groupe trifluorométhoxy ou un groupe trifluorométhyle, n^{31} et n^{32} représentent chacun indépendamment 0, 1 ou 2, $n^{31} + n^{32}$ représente 0, 1 ou 2, et lorsqu'une pluralité de M^{31} ou M^{33} sont présents, les plusieurs M^{31} peuvent être identiques ou différents et les plusieurs M^{33} peuvent être identiques ou différents, et au moins un composé choisi dans le groupe constitué des composés représentés par la formule générale (II-a) à la formule générale (II-e),

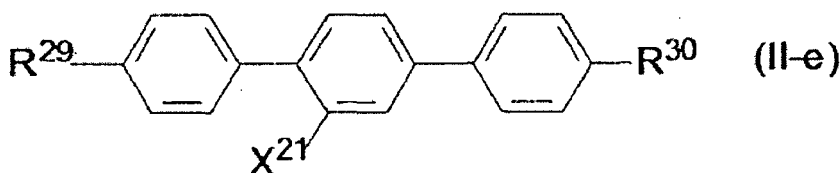
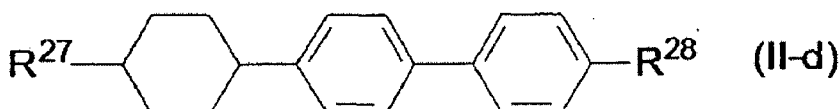
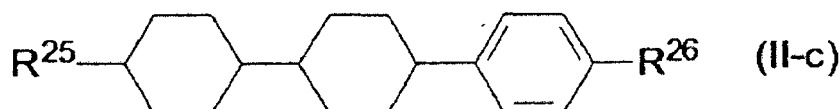
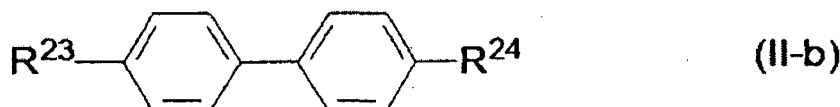
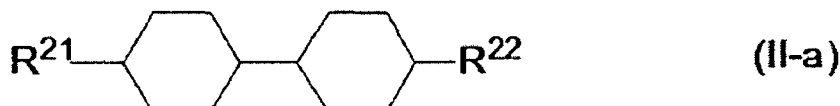

dans les formules générales, R^{21} à R^{30} représentent chacun indépendamment un groupe alkyle comportant de 1 à 10 atomes de carbone ou un groupe alcényle comportant de 2 à 10 atomes de carbone, et X^{21} représente un atome d'hydrogène ou un atome de fluor ;

les parties de pixel à trois couleurs RVB contiennent, dans une partie de pixel V en tant que matériau colorant, un pigment de phtalocyanine métallique halogénée comprenant un métal central choisi dans le groupe constitué de Al, Si, Sc, Ti, V, Mg, Fe, Co, Ni, Zn, Ga, Ge, Y, Zr, Nb, In, Sn et Pb ; lorsque le métal central est un métal trivalent, l'un quelconque d'un atome d'halogène, d'un groupe hydroxyle et d'un groupe acide sulfonique est lié au métal central ou le métal central forme un pont oxo ou un pont thio ; et, lorsque le métal central est un métal tétravalent, un atome d'oxygène unique ou deux quelconques d'un atome d'halogène, d'un groupe hydroxyle et d'un groupe

acide sulfonique qui peuvent être identiques ou différents sont liés au métal central.

- 5
2. Dispositif d'affichage à cristaux liquides selon la revendication 1, dans lequel les parties de pixel à trois couleurs RVB contiennent, en tant que matériaux colorants, un pigment dicétopyrrolopyrrole et/ou un colorant organique rouge anionique dans une partie de pixel R et un pigment de phtalocyanine de cuivre de type ϵ et/ou un colorant organique bleu cationique dans une partie de pixel B.
- 10
3. Dispositif d'affichage à cristaux liquides selon la revendication 1 ou 2, dans lequel les parties de pixel à trois couleurs RVB contiennent, en tant que matériaux colorants, le C.I. Solvent Red 124 dans une partie de pixel R et le C.I. Solvent Blue 7 dans une partie de pixel B.
- 15
4. Dispositif d'affichage à cristaux liquides selon la revendication 1 ou 2, dans lequel les parties de pixel à trois couleurs RVB contiennent, en tant que matériaux colorants, le C.I. Pigment Red 254 dans une partie de pixel R et le C.I. Pigment Blue 15:6 dans une partie de pixel B.
- 20
5. Dispositif d'affichage à cristaux liquides selon l'une quelconque des revendications 1 à 4, dans lequel la partie de pixel V contient un pigment de phtalocyanine de zinc halogénée qui inclut le Zn en tant que métal central et dans lequel de 8 à 16 atomes d'halogène par molécule de phtalocyanine sont liés aux noyaux benzène d'une molécule de phtalocyanine.
- 25
6. Dispositif d'affichage à cristaux liquides selon l'une quelconque des revendications 1 à 5, dans lequel la partie de pixel V contient le C.I. Pigment Green 58.
- 30
7. Dispositif d'affichage à cristaux liquides selon l'une quelconque des revendications 1 à 6, dans lequel la partie de pixel V contient en outre au moins un colorant/pigment organique choisi dans le groupe constitué du C.I. Pigment Yellow 150, 215, 185 et 138 et du C.I. Solvent Yellow 21, 82, 83:1 et 33.
- 35
8. Dispositif d'affichage à cristaux liquides selon l'une quelconque des revendications 1 à 7, dans lequel le filtre coloré est constitué de la matrice noire, des parties de pixel à trois couleurs RVB, et d'une partie de pixel J, et la partie de pixel J contient, en tant que matériau colorant, au moins un colorant/pigment organique jaune choisi dans le groupe constitué du C.I. Pigment Yellow 150, 215, 185, 138 et 139 et du C.I. Solvent Yellow 21, 82, 83:1, 33 et 162.
9. Dispositif d'affichage à cristaux liquides selon l'une quelconque des revendications 1 à 8, dans lequel le composé représenté par la formule générale (I) inclut les composés représentés par la formule générale (I-a) à la formule générale (I-f),

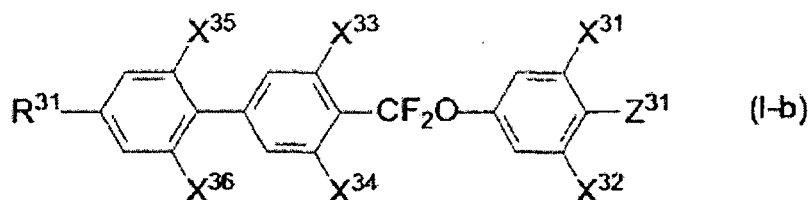
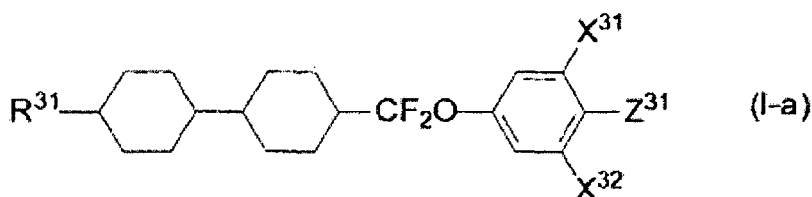

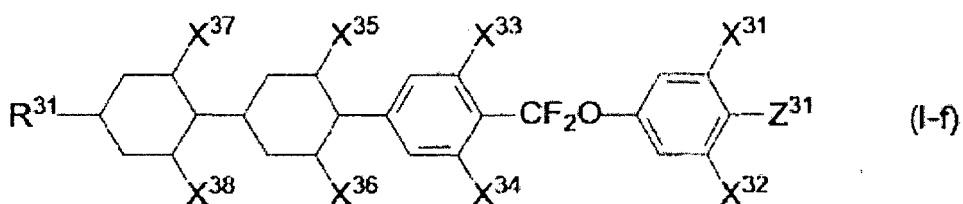
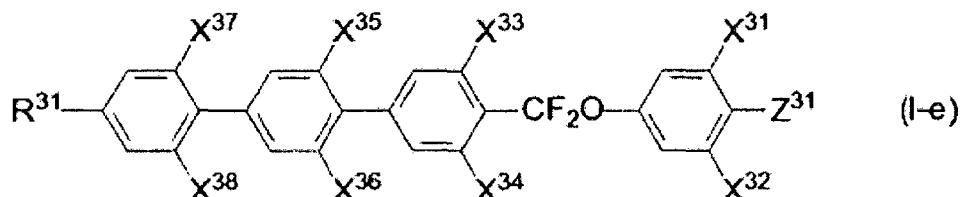
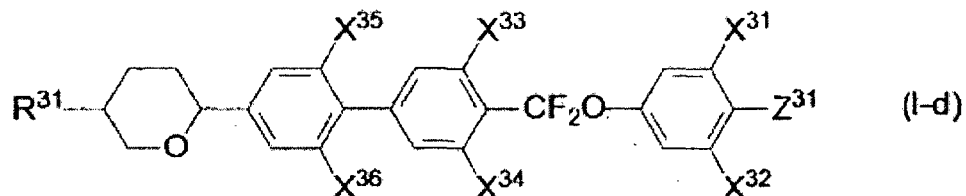
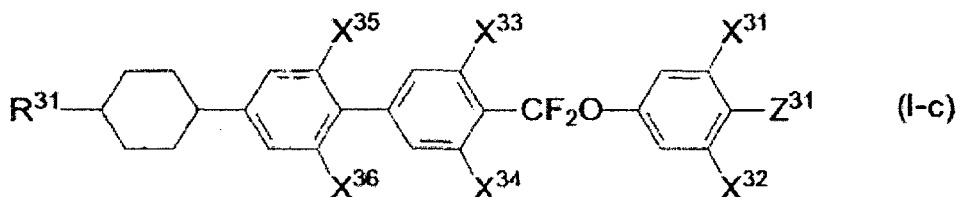

35 dans les formules générales, R³¹ représente un groupe alkyle ou un groupe alcoxy comportant de 1 à 10 atomes de carbone ou un groupe alcényle ou un groupe alcényloxy comportant de 2 à 10 atomes de carbone, X³¹ à X³⁸ représentent chacun indépendamment un atome d'hydrogène ou un atome de fluor, et Z³¹ représente un atome de fluor, un groupe trifluorométhoxy ou un groupe trifluorométhyle.

- 40 10. Dispositif d'affichage à cristaux liquides selon l'une quelconque des revendications 1 à 9, dans lequel la couche à composition de cristaux liquides contient en outre au moins un composé choisi dans le groupe constitué des composés représentés par la formule générale (III-a) à la formule générale (III-f),

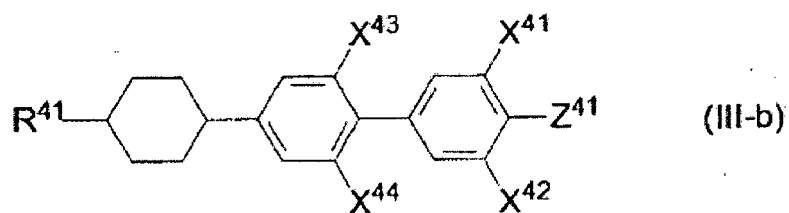
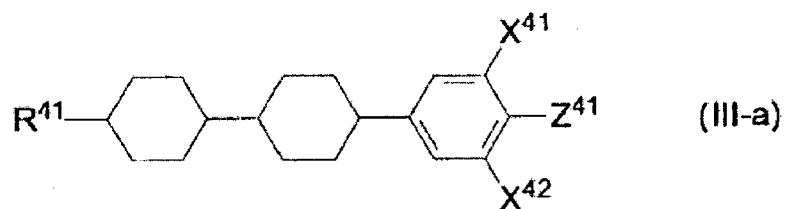

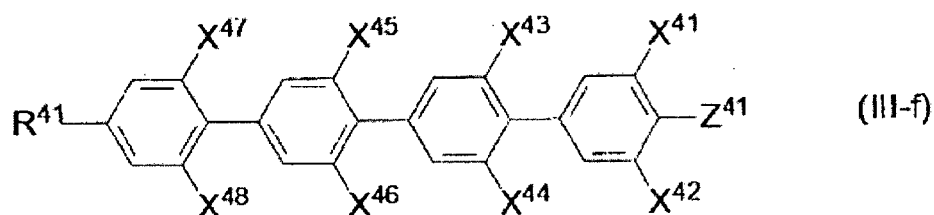
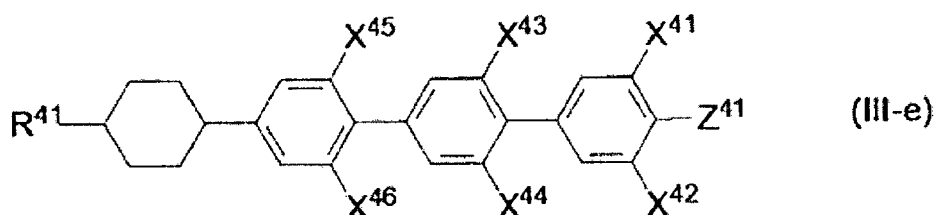
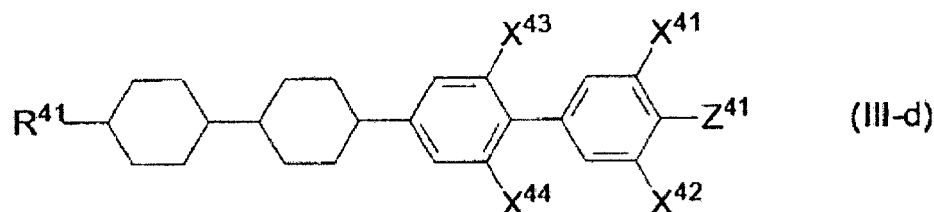
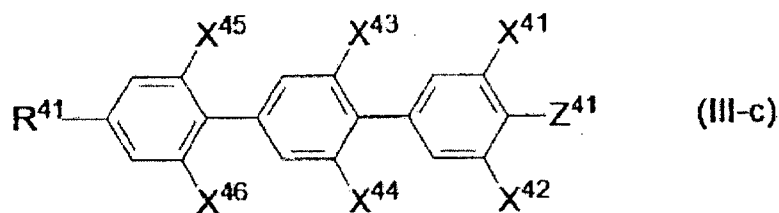

25

30

dans les formules générales, R⁴¹ représente un groupe alkyle ou un groupe alcoxy comportant de 1 à 10 atomes de carbone ou un groupe alcényle ou un groupe alcényloxy comportant de 2 à 10 atomes de carbone, X⁴¹ à X⁴⁸ représentent chacun indépendamment un atome d'hydrogène ou un atome de fluor, et Z⁴¹ représente un atome de fluor, un groupe trifluorométhoxy ou un groupe trifluorométhyle.

35

40

11. Dispositif d'affichage à cristaux liquides selon l'une quelconque des revendications 1 à 10, dans lequel la couche à composition de cristaux liquides contient un polymère obtenu par polymérisation d'une composition de cristaux liquides contenant au moins un composé polymérisable.

45

12. Dispositif d'affichage à cristaux liquides selon l'une quelconque des revendications 1 à 11, dans lequel la couche à composition de cristaux liquides contient un monomère bifonctionnel représenté par la formule générale (V),

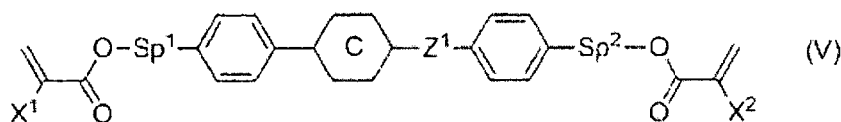

55

dans la formule générale, X¹ et X² représentent chacun indépendamment un atome d'hydrogène ou un groupe méthyle ; Sp¹ et Sp² représentent chacun indépendamment une liaison simple, un groupe alkylène comportant de 1 à 8 atomes de carbone ou un groupe -O-(CH₂)_s-, où s représente un nombre entier de 2 à 7 et l'atome d'oxygène est lié à un noyau aromatique ; Z¹ représente un groupe -OCH₂-, -CH₂O-, -COO-, -OCO-, -CF₂O-, -OCF₂-, -CH₂CH₂-, -CF₂CF₂-, -CH=CH-COO-, -CH=CH-OCO-, -COO-CH=CH-, -OCO-CH=CH-, -COO-CH₂CH₂-, -OCO-CH₂CH₂-, -CH₂CH₂-COO-, -CH₂CH₂-OCO-, -COO-CH₂-, -OCO-CH₂-, -CH₂-COO-, -CH₂-OCO-, -CY¹=CY²-, où Y¹ et Y² représentent chacun indépendamment un atome de fluor ou un atome d'hydrogène, un groupe -C≡C-, ou une liaison simple ; et C représente un groupe 1,4-phénylène, un groupe trans-1,4-cyclohexylène ou une liaison simple et, dans tous les groupes 1,4-phénylène de la formule générale, l'un quelconque des atomes d'hydrogène peut être substitué par des atomes de fluor.

FIG. 1

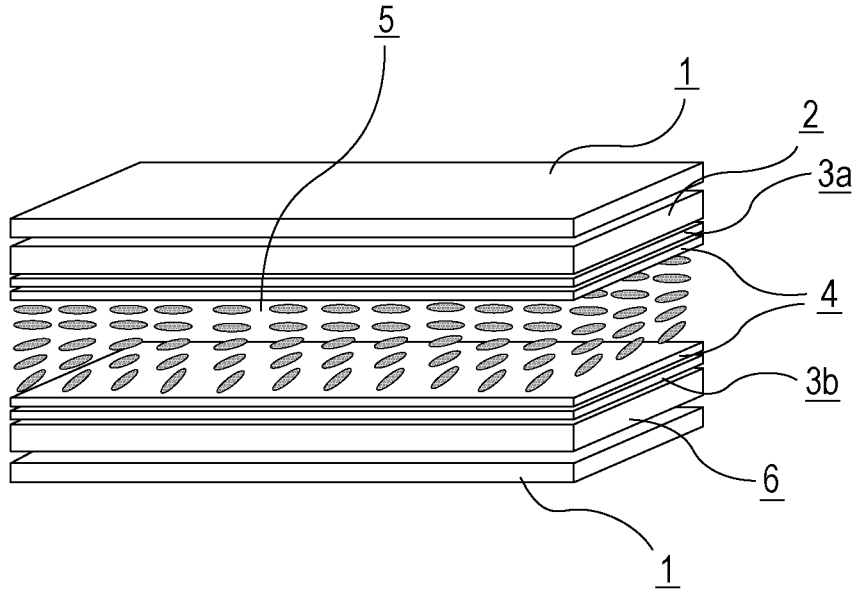
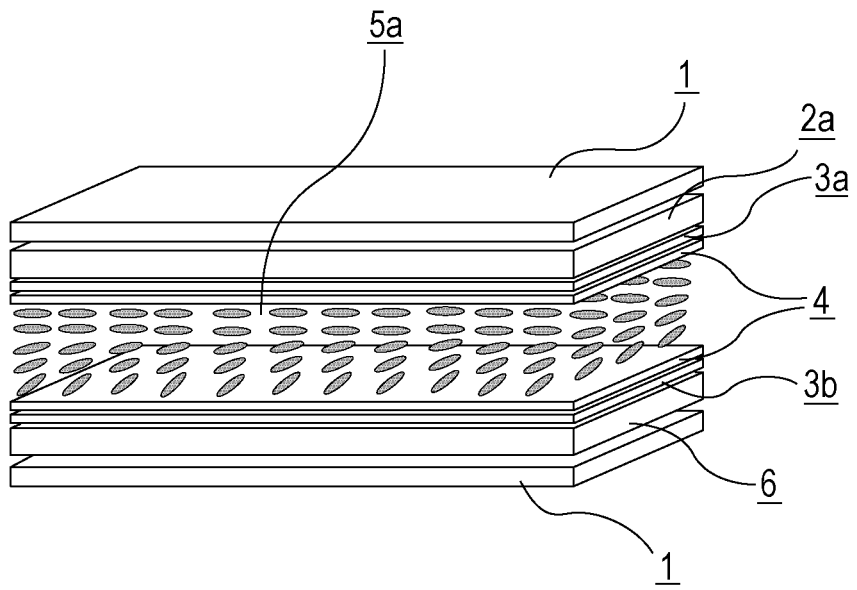

FIG. 2



REFERENCES CITED IN THE DESCRIPTION

This list of references cited by the applicant is for the reader's convenience only. It does not form part of the European patent document. Even though great care has been taken in compiling the references, errors or omissions cannot be excluded and the EPO disclaims all liability in this regard.

Patent documents cited in the description

- JP 2000019321 A [0007]
- JP 2009109542 A [0007]
- JP 2000192040 A [0008] [0009]
- US 8178173 B1 [0010]
- US 20110058138 A1 [0010]
- US 20100097562 A1 [0010]

专利名称(译)	液晶显示装置		
公开(公告)号	EP2796922B1	公开(公告)日	2016-10-05
申请号	EP2013798537	申请日	2013-02-21
[标]申请(专利权)人(译)	大日本油墨化学工业株式会社		
申请(专利权)人(译)	DIC株式会社		
当前申请(专利权)人(译)	DIC株式会社		
[标]发明人	KURIYAMA TAKESHI KAWAMURA JOUJI KIMURA AKIRA FUNAKURA SEIJI SHIMADA KATSUNORI		
发明人	KURIYAMA, TAKESHI KAWAMURA, JOUJI KIMURA, AKIRA FUNAKURA, SEIJI SHIMADA, KATSUNORI		
IPC分类号	G02F1/1335 C09K19/12 C09K19/20 C09K19/30 C09K19/34 C09K19/38 C09K19/54 G02B5/20 G02F1/13 C09K19/44 C09K19/04 G02F1/1333		
CPC分类号	G02F1/133514 C09K19/20 C09K19/3066 C09K19/44 C09K19/54 C09K2019/0448 C09K2019/0466 C09K2019/122 C09K2019/123 C09K2019/3004 C09K2019/301 C09K2019/3016 C09K2019/3422 G02F1/133512 G02F2001/133397 G02F2202/04		
其他公开文献	EP2796922A1 EP2796922A4		
外部链接	Espacenet		

摘要(译)

液晶显示装置技术领域本发明涉及一种液晶显示装置，其包括特定的液晶组合物和使用特定颜料的滤色器。本发明提供一种液晶显示装置，其中防止了液晶层的电压保持率（VHR）的降低和离子密度（ID）的增加以及诸如白色条纹，取向不均匀的显示缺陷的问题。克服了图像残留。本发明的液晶显示装置，其中防止了液晶层的电压保持率（VHR）的降低和离子密度（ID）的增加，并且克服了诸如图像残留的显示缺陷的问题。特别适用于具有IPS模式和FFS模式的有源矩阵驱动液晶显示装置，并且可应用于液晶电视，监视器，蜂窝电话和智能电话的液晶显示装置。

