



(11) **EP 2 657 754 A1**

(12) **EUROPEAN PATENT APPLICATION**
published in accordance with Art. 153(4) EPC

(43) Date of publication:
30.10.2013 Bulletin 2013/44

(21) Application number: **12860188.7**

(22) Date of filing: **14.12.2012**

(51) Int Cl.:
G02F 1/1335 (2006.01) **C09K 19/12** (2006.01)
C09K 19/14 (2006.01) **C09K 19/20** (2006.01)
C09K 19/30 (2006.01) **C09K 19/32** (2006.01)
C09K 19/34 (2006.01) **C09K 19/38** (2006.01)
G02B 5/20 (2006.01) **G02F 1/13** (2006.01)

(86) International application number:
PCT/JP2012/082521

(87) International publication number:
WO 2013/094537 (27.06.2013 Gazette 2013/26)

(84) Designated Contracting States:
AL AT BE BG CH CY CZ DE DK EE ES FI FR GB GR HR HU IE IS IT LI LT LU LV MC MK MT NL NO PL PT RO RS SE SI SK SM TR

(30) Priority: **19.12.2011 JP 2011277090**

(71) Applicant: **DIC Corporation**
Tokyo 174-8520 (JP)

(72) Inventors:
• **KANEOYA, Masakazu**
Kitaadachi-gun, Saitama 362-8577 (JP)

- **TAKEUCHI, Kiyofumi**
Kitaadachi-gun, Saitama 362-8577 (JP)
- **FUNAKURA, Seiji**
Kamisu-shi, Ibaraki 314-0193 (JP)
- **SHIMADA, Katsunori**
Sakura-shi, Chiba 285-8668 (JP)

(74) Representative: **Albrecht, Thomas**
Kraus & Weisert
Patent- und Rechtsanwälte
Thomas-Wimmer-Ring 15
80539 München (DE)

(54) **LIQUID CRYSTAL DISPLAY DEVICE**

(57) The present invention relates to a liquid crystal display device using a specified liquid crystal composition and a color filter including a specified dye and/or pigment.

The present invention provides a liquid crystal display device capable of preventing a decrease in voltage holding ratio (VHR) of a liquid crystal layer and an increase in ion density (ID) and resolving the problem of display defects such as white spots, alignment unevenness, image sticking, and the like.

The liquid crystal display device of the present invention is characterized by preventing a decrease in voltage holding ratio (VHR) of a liquid crystal layer and an increase in ion density (ID) and suppressing the occurrence of display defects such as image sticking and the like, and is thus particularly useful for a VA-mode or PS-VA-mode liquid crystal display device for active matrix driving, and can be applied to liquid crystal display devices such as a liquid crystal TV, a monitor, a cellular phone, a smart phone, and the like.

FIG. 2

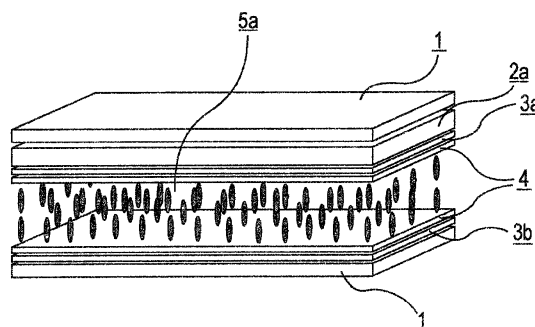

EP 2 657 754 A1

Description

Technical Field

5 **[0001]** The present invention relates to a liquid crystals display device.

Background Art

10 **[0002]** Liquid crystal display devices have been used for watches and electronic calculators, various household electric appliances, measuring apparatuses, automotive panels, word processors, electronic notebooks, printers, computers, televisions, etc. Typical examples of a liquid crystal display mode include a TN (twisted nematic) mode, a STN (super twisted nematic) mode, a DS (dynamic light scattering) mode, a GH (guest-host) mode, an IPS (in-plane switching) mode, an OCB (optically compensated birefringence) mode, an ECB (electrically controlled birefringence) mode, a VA (vertical alignment) mode, a CSH (color super-homeotropic) mode, a FLC (ferroelectric liquid crystal), and the like. Also, multiplex driving is popularized as a driving method instead of usual static driving, and a simple matrix method and a recent active matrix (AM) method of driving by TFT (thin-film transistor), TFD (thin-film diode), or the like become the mainstream.

15 **[0003]** As shown in Fig. 1, a general color liquid crystal display device includes two substrates (1) each having an alignment film (4), a transparent electrode layer (3a) serving as a common electrode and a color filter layer (2) which are disposed between one of the alignment films and the substrate, and a pixel electrode layer (3b) disposed between the other alignment film and the substrate, the substrates are arranged so that the alignment films thereof face each other, and a liquid crystal layer (5) is held between the substrates.

The color filter layer is composed of a black matrix and a color filter including a red color layer (R), a green color layer (G), a blue color layer (B), and, if required, a yellow color layer (Y).

20 Liquid crystal materials constituting liquid crystal layers have undergone a high level of impurity control because impurities remaining in the materials significantly affect electric characteristics of display devices. In addition, with respect to materials constituting alignment films, it has already been known that an alignment film is in direct contact with a liquid crystal layer, and impurities remaining in the alignment film are moved to the liquid crystal layer and affect the electric characteristics of the liquid crystal layer, and thus characteristics of a liquid crystal display device due to impurities in an alignment film material have been being investigated.

25 **[0004]** On the other hand, with respect to materials such as organic pigments and the like used in the color filter layers, like the alignment film materials, it is supposed that impurities contained affect the liquid crystal layers. However, an alignment film and a transparent electrode are interposed between the color filter layer and the liquid crystal layer, and thus it has been considered that the direct influence on the liquid crystal layer is greatly smaller than that of the alignment film material. However, the alignment film generally has a thickness of as small as 0.1 μm or less, and the transparent electrode, for example, even a common electrode used on the color filter layer side and having a thickness increased for enhancing conductivity, generally has a thickness of 0.5 μm or less. Therefore, the color filter layer and the liquid crystal layer are not put in a completely isolated environment, and the color filter layer has the possibility of developing display defects such as white spots, alignment unevenness, image sticking, and the like due to a decrease in voltage holding ratio (VHR) of the liquid crystal layer and an increase in ion density (ID) which are caused by impurities contained in the color filter layer through the alignment film and the transparent electrode.

30 **[0005]** As a method for resolving the display defects due to impurities contained in pigments which constitute a color filter, there have been studied a method of controlling elusion of impurities into a liquid crystal by using a pigment in which a ratio of an extract with ethyl formate is decreased to a specified value or less (Patent Literature 1), and a method of controlling elusion of impurities into a liquid crystal by specifying a pigment in a blue color layer (Patent Literature 2). However, these methods are not much different from a method of simply decreasing impurities in a pigment, and are thus unsatisfactory for improvement for resolving the display defects even in the present situation in which a pigment purifying technique has recently been advanced.

35 **[0006]** On the other hand, with attention paid to a relation between organic impurities contained in a color filter and a liquid crystal composition, there are disclosed a method of specifying a hydrophobic parameter of liquid crystal molecules contained in a liquid crystal layer to be equal to or higher than a predetermined value, the hydrophobic parameter representing insolubility of the organic impurities in the liquid crystal layer, and a method of preparing a liquid crystal composition containing a predetermined ratio or more of a liquid crystal compound having $-\text{OCF}_3$ groups at the ends of liquid crystal molecules because the $-\text{OCF}_3$ groups at the ends of liquid crystal molecules have a correlation to the hydrophobic parameter (Patent Literature 3).

40 However, these cited documents each disclose an invention based on the principle that the influence of impurities in a pigment on a liquid crystal layer is suppressed and disclose no research on a direct relation between a structure of a liquid crystal material and a structure of a colorant such as a dye/pigment or the like used in a color filter, not leading to

the resolution of the problem of display defects in advanced liquid crystal display devices.

Citation List

5 Patent Literature

[0007]

10 PAL 1: Japanese Unexamined Patent Application Publication No. 2000-19321
PTL 2: Japanese Unexamined Patent Application Publication No. 20C9-109542
PTL 3: Japanese Unexamined Patent Application Publication No. 2000-192040

Summary of Invention

15 Technical Problem

[0008] The present invention is aimed at providing a liquid crystal display device including a specified liquid crystal composition and a color filter using a specified dye and/or pigment in order to prevent a decrease in voltage holding ratio (VHR) of a liquid crystal layer and an increase in ion density (ID), thereby resolving the problems of display defects such as white spots, alignment unevenness, image sticking, and the like.

Solution to Problem

25 **[0009]** In order to solve the above-described problems, the inventors intensively studied combinations of colorants such as a dye/pigment and the like which constitute a color filter and structures of liquid crystal materials constituting a liquid crystal layer. As a result it was found that a liquid crystal display device using a specified-structure liquid crystal composition and a color filter containing a specified-structure dye and/or pigment prevents a decrease in voltage holding ratio (VHR) of a liquid crystal layer and an increase in ion density (ID), thereby resolving the problems of display defects such as white spots, alignment unevenness, image sticking, and the like. This led to the achievement of the present invention.

30 **[0010]** That is, the present invention provides a liquid crystal display device including a first substrate, a second substrate, a liquid crystal composition layer held between the first substrate and the second substrate, a color filter including a black matrix and at least RGB three-color pixel portions, a pixel electrode, and a common electrode, the liquid crystal composition layer including a liquid crystal composition which contains at least one compound selected from a compound group represented by general formula (LC1) to general formula (LC4),

[0011]

[Chem. 1]

40

45

50

55

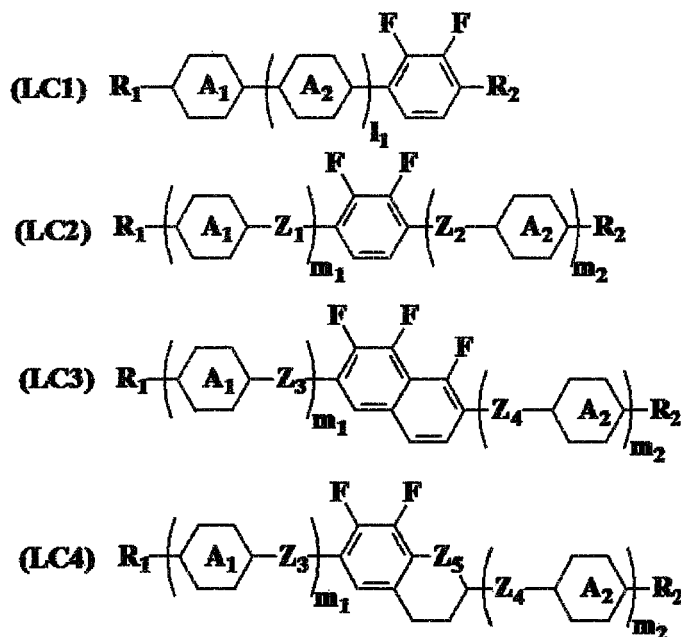

25 [0012] (in the formulae, R_1 and R_2 each independently represent an alkyl group having 1 to 15 carbon atoms, at least one CH_2 group in the alkyl group may be substituted by $-\text{O}-$, $-\text{CH}=\text{CH}-$, $-\text{CO}-$, $-\text{OCO}-$, $-\text{COO}-$, $-\text{C}\equiv\text{C}-$, $-\text{CF}_2\text{O}-$, or $-\text{OCF}_2-$ so that oxygen atoms are not directly adjacent to each other, at least one hydrogen atom in the alkyl group may be arbitrarily substituted by a halogen, A_1 and A_2 each independently represent any one of the following structures,

[0013]

30 [Chem. 2]

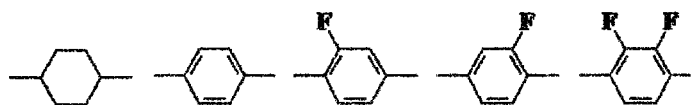

40 [0014] (at least one CH_2 group in a cyclohexane ring in the structures may be substituted by an oxygen atom, at least one CH group in a benzene ring in the structures may be substituted by a nitrogen atom, and at least one hydrogen atom in the structures may be substituted by Cl , CF_3 , or OCF_3), Z_1 to Z_4 each independently represent a single bond, $-\text{CH}=\text{CH}-$, $-\text{C}\equiv\text{C}-$, $-\text{CH}_2\text{CH}_2-$, $-(\text{CH}_2)_4-$, $-\text{COO}-$, $-\text{OCH}_2-$, $-\text{CH}_2\text{O}-$, $-\text{OCF}_2-$, or $-\text{CF}_2\text{O}-$, Z_5 represents a CH_2 group or an oxygen atom, at least one of Z_1 and Z_2 present is not a single bond, l_1 represents 0 or 1, m_1 and m_2 each independently represent 0 to 3, and $m_1 + m_2$ is 1, 2, or 3), and the RGB three-color pixel portions including, as colorants, a diketopyrrolopyrrole pigment and/or anionic red organic dye in a R pixel portion, at least one selected from the group consisting of a halogenated copper phthalocyanine pigment, a phthalocyanine green dye, and a mixture of a phthalocyanine blue dye and an azo yellow organic dye in a G pixel portion, and a ϵ -type copper phthalocyanine pigment and/or cationic blue organic dye in a B pixel portion.

Advantageous Effects of Invention

50 [0015] A liquid crystal display device according to the present invention is capable of preventing a decrease in voltage holding ratio (VHR) of a liquid crystal layer and an increase in ion density (ID) by using a specified liquid crystal composition and a color filter including a specified dye and/or pigment, thereby preventing the occurrence of display defects such as white spots, alignment unevenness, image sticking, and the like.

Description of Embodiments

55 [0016] Fig. 2 shows an example of a liquid crystal display device according to the present invention. Two substrates (1) including a first substrate and a second substrate each have an alignment film (4), a transparent electrode layer (3a) serving as a common electrode and a color filter layer (2a) containing a specified dye and/or pigment are disposed

between one of the alignment films (4) and the substrate, a pixel electrode layer (3b) is disposed between the other alignment film and the substrate, the substrates are arranged so that the alignment films face each other, and a liquid crystal layer (5a) containing a specified liquid crystal composition is held between the substrates.

The two substrates in the display device are bonded together with a sealing material disposed in a peripheral region, and in many cases, a granular spacer or a resin spacer columns formed by a photolithography method is disposed between the substrates in order to maintain a gap between the substrates.

(Liquid crystal layer)

[0017] The liquid crystal layer in the liquid crystal display device of the present invention preferably includes a liquid crystal composition which contains at least one compound selected from a compound group represented by general formula (LC1) to general formula (LC4),

[0018]

[Chem. 3]

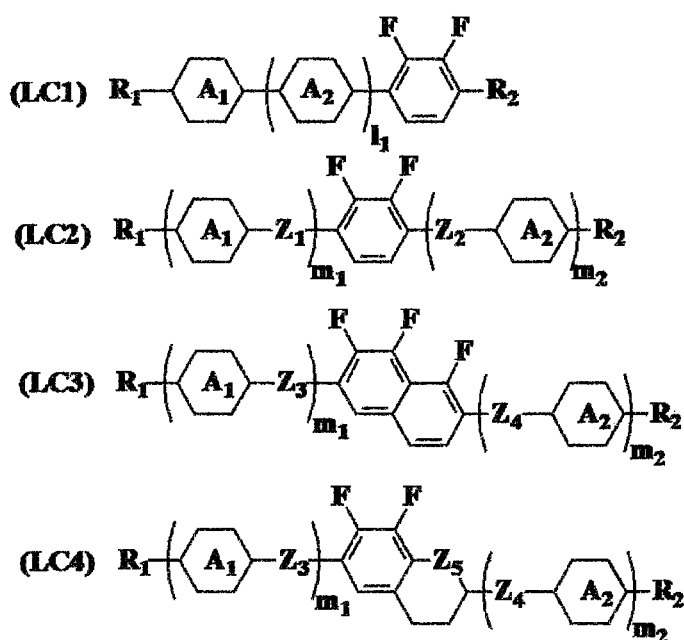

[0019] (in the formulae, R_1 and R_2 each independently represent an alkyl group having 1 to 15 carbon atoms, at least one CH_2 group in the alkyl group may be substituted by $-\text{O}-$, $-\text{CH}=\text{CH}-$, $-\text{CO}-$, $-\text{OCO}-$, $-\text{COO}-$, $-\text{C}\equiv\text{C}-$, $-\text{CF}_2\text{O}-$, or $-\text{OCF}_2-$ so that oxygen atoms are not directly adjacent to each other, at least one hydrogen atom in the alkyl group may be arbitrarily substituted by a halogen, A_1 and A_2 each independently represent any one of the following structures,

[0020]

[Chem. 4]

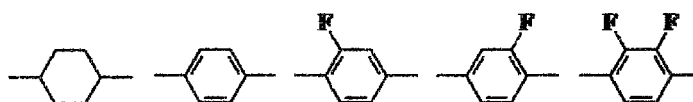

[0021] (at least one CH_2 group in a cyclohexane ring in the structures may be substituted by an oxygen atom, at least one CH group in a benzene ring in the structures may be substituted by a nitrogen atom, and at least one hydrogen atom in the structures may be substituted by Cl , CF_3 , or OCF_3), Z_1 to Z_4 each independently represent a single bond, $-\text{CH}=\text{CH}-$, $-\text{C}\equiv\text{C}-$, $-\text{CH}_2\text{CH}_2-$, $-(\text{CH}_2)_4-$, $-\text{COO}-$, $-\text{OCH}_2-$, $-\text{CH}_2\text{O}-$, $-\text{OCF}_2-$, or $-\text{CF}_2\text{O}-$, Z_5 represents a CH_2 group or an oxygen atom, at least one of Z_1 and Z_2 present is not a single bond, l_1 represents 0 or 1, m_1 and m_2 each independently represent 0 to 3, and $m_1 + m_2$ is 1, 2, or 3).

Preferably, R_1 and R_2 each independently represent an alkyl group having 1 to 7 carbon atoms, an alkoxy group having

1 to 7 carbon atoms, or an alkenyl group having 2 to 7 carbon atoms.
 Preferably, A₁ and A₂ each independently represent any one of the following structures,
[0022]

5 [Chem. 5]

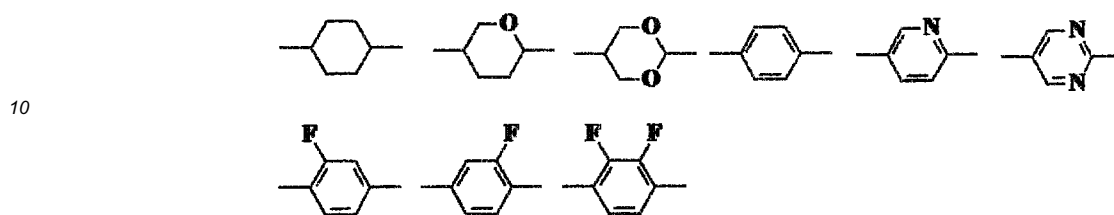

15 **[0023]** Preferably, Z₁ to Z₄ each independently represent a single bond, -CH₂CH₂-, -COO-, -OCH₂-, -CH₂O-, -OCF₂-, or -CF₂O-.

[0024] The liquid crystal composition preferably further contains at least one compound represented by general formula (LC5),

[0025]

20

[Chem. 6]

25

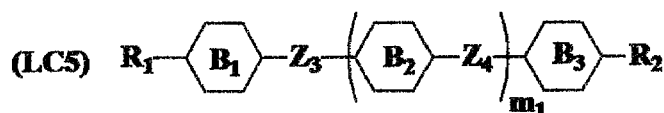

30 **[0026]** (in the formulae, R₁ and R₂ each independently represent an alkyl group having 1 to 15 carbon atoms, at least one CH₂ group in the alkyl group may be substituted by -O-, -CH=CH-, -CO-, -OCO-, -COO-, -C≡C-, -CF₂O-, or -OCF₂- so that oxygen atoms are not directly adjacent to each other, at least one hydrogen atom in the alkyl group may be arbitrarily substituted by a halogen, B₁ to B₃ each independently represent any one of the following,

[0027]

35 [Chem. 7]

40

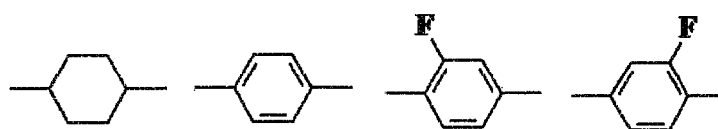

45 **[0028]** (in the formulae, at least one CH₂CH₂ group in a cyclohexane ring may be substituted by -CH=CH-, -CF₂O-, or -OCF₂-, and at least one CH group in a benzene ring may be substituted by a nitrogen atom), Z₃ and Z₄ each independently represent a single bond, -CH=CH-, -C≡C-, -CH₂CH₂-, -(CH₂)₄-, -COO-, -OCH₂-, -CH₂O-, -OCF₂-, or -CF₂O-, at least one of Z₁ and Z₂ is not a single bond, and m₁ represents 0 to 3).

Preferably, R₁ and R₂ each independently represent an alkyl group having 1 to 7 carbon atoms, an alkoxy group having 1. to 7 carbon atoms, or an alkenyl group having 2 to 7 carbon atoms.

Preferably, B₁ to B₃ each independently represent any one of the following structures.

[0029]

50

[Chem. 8]

55

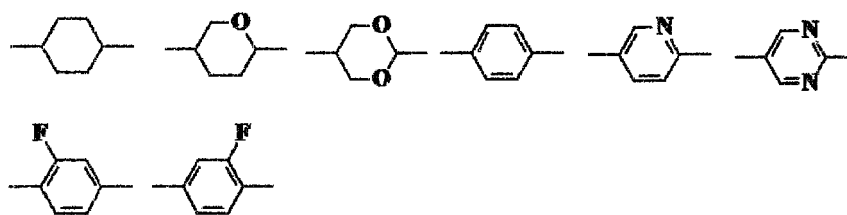

[0030] Preferably, Z_3 and Z_4 each independently represent a single bond, $-\text{CH}_2\text{CH}_2-$, $-\text{COO}-$, $-\text{OCH}_2-$, $-\text{CH}_2\text{O}-$, $-\text{OCF}_2-$, or $-\text{CF}_2\text{O}-$.

[0031] The general formula (LC1) more preferably represents at least one compound selected from the group consisting of compounds represented by general formula (LC1) -1 to general formula (LC1) -7 below,

[0032]

[Chem. 9]

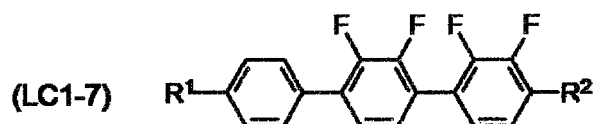
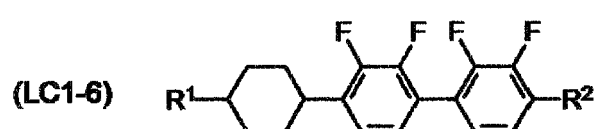
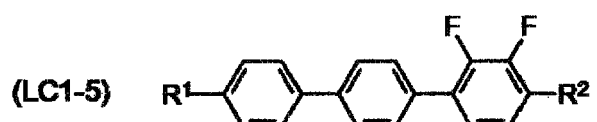
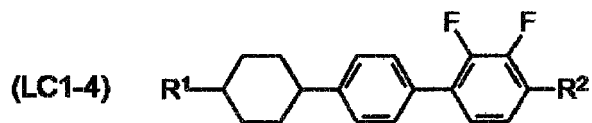
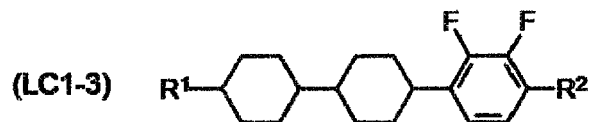
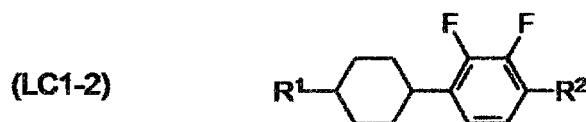
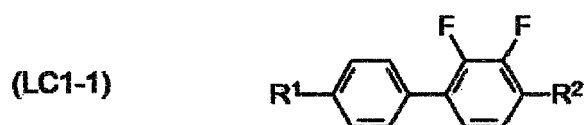

[0033] (in the formulae, R_1 and R_2 each independently represent an alkyl group having 1 to 7 carbon atoms, an alkoxy group having 1 to 7 carbon atoms, an alkenyl group having 2 to 7 carbon atoms, or an alkenyloxy group having 2 to 7 carbon atoms).

[0034] The general formula (LC2) more preferably represents at least one compound selected from the group consisting of compounds represented by general formula (LC2) -1 to general formula (LC2) -15 below,

[0035]

[Chem. 10]

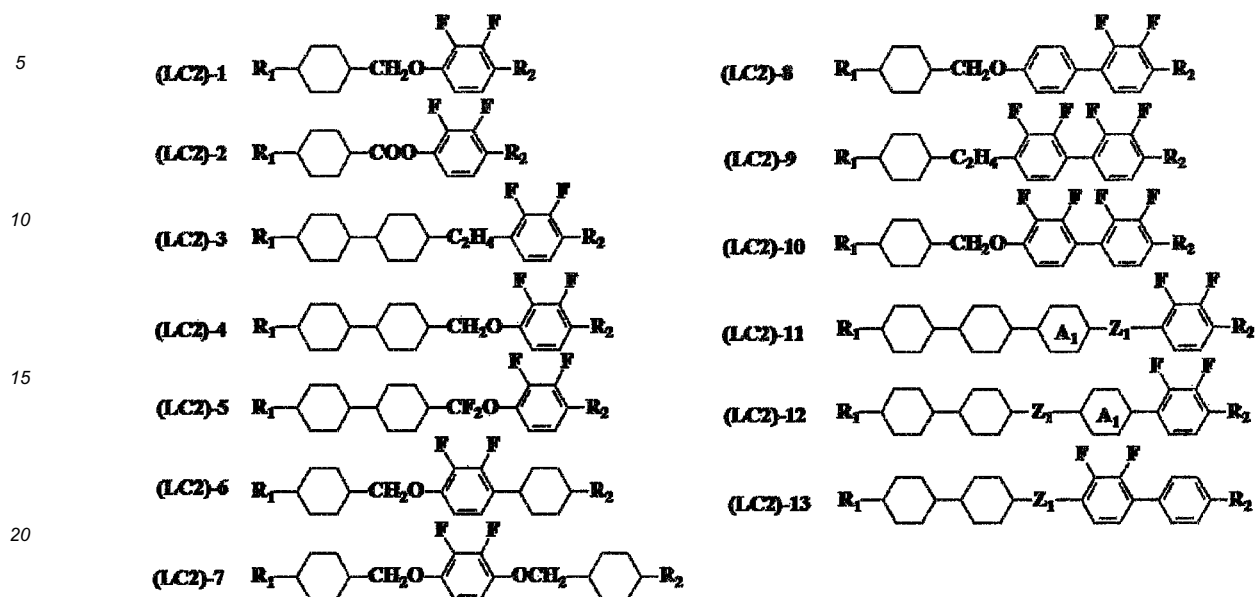

[0036]

[Chem. 11]

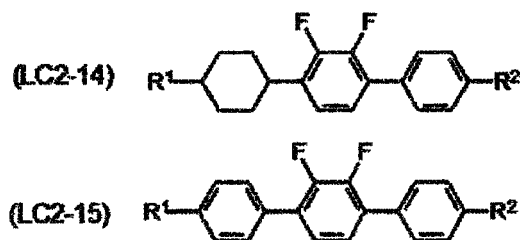

[0037] (in the formulae, R₁ and R₂ each independently represent an alkyl group having 1 to 7 carbon atoms, an alkoxy group having 1 to 7 carbon atoms, an alkenyl group having 2 to 7 carbon atoms, or an alkenyloxy group having 2 to 7 carbon atoms, and Z¹ represents -CH₂CH₂-, -OCH₂-, -CH₂O-, -OCF₂-, or -CF₂O-, and A¹ represents any one of the following structures).

[0038]

[Chem. 12]



[0039] The general formula (LC3) more preferably represents at least one compound selected from the group consisting of compounds represented by general formula (LC3) -1 to general formula (LC3) -6 below, and the general formula (LC4) more preferably represents at least one compound selected from the group consisting of compounds represented by general formula (LC4) -1 to general formula (LC4) -4 below,

[0040]

[Chem. 13]

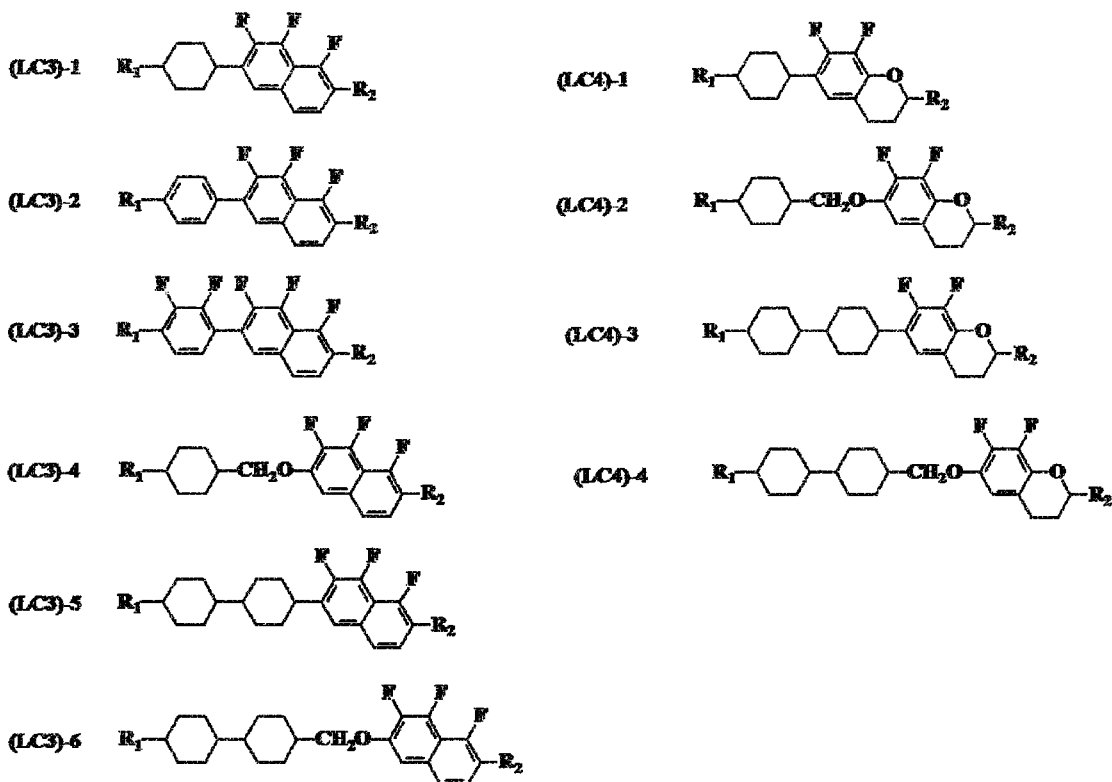

[0041] (in the formulae, R₁ and R₂ each independently represent an alkyl group having 1 to 7 carbon atoms, an alkoxy group having 1 to 7 carbon atoms, an alkenyl group having 2 to 7 carbon atoms, or an alkenyloxy group having 2 to 7 carbon atoms).

[0042] The general formula (LC5) more preferably represents at least one compound selected from the group consisting of compounds represented by general formula (LC5) -1 to general formula (LC5) -13 below,

[0043]

[Chem. 14]

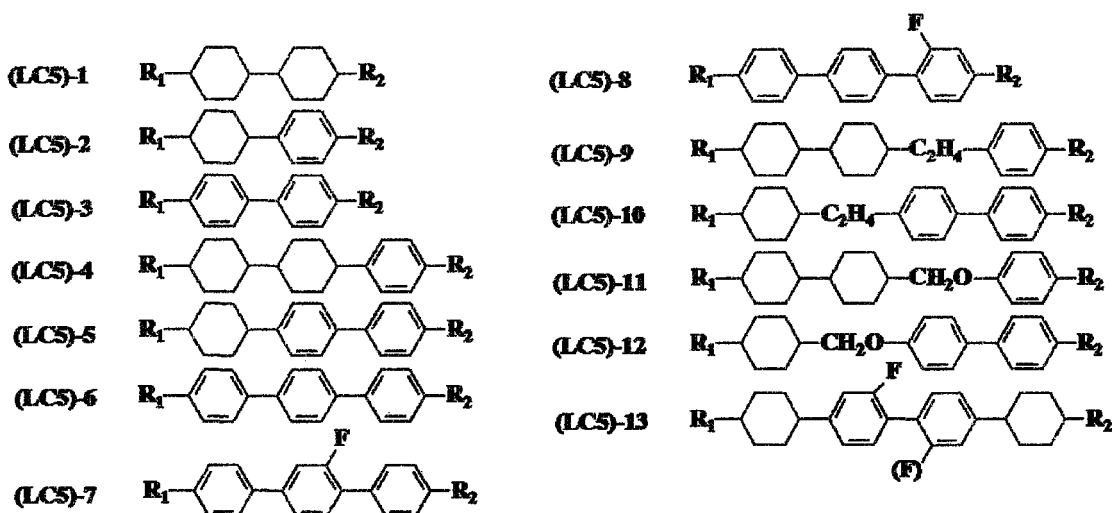

[0044] (in the formulae, R₁ and R₂ each independently represent an alkyl group having 1 to 7 carbon atoms, an alkoxy group having 1 to 7 carbon atoms, an alkenyl group having 2 to 7 carbon atoms, or an alkenyloxy group having 2 to 7 carbon atoms).

[0045] The liquid crystal composition layer may contain at least one polymerizable compound. The polymerizable compound is preferably a disk-shaped liquid crystal compound having a structure in which a benzene derivative, a

triphenylene derivative, a truxene derivative, a phthalocyanine derivative, or a cyclohexane derivative serves as a central mother nucleus of a molecule and is radially substituted by linear alkyl groups, linear alkoxy groups, or substituted benzoyloxy groups as side chains.

[0046] Specifically, the polymerizable compound is preferably a polymerizable compound represented by general formula (PC1),

[0047] [Chem. 15]

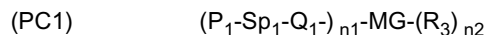

[0048] (in the formula, P_1 represents a polymerizable functional group, Sp_1 represents a spacer group having 0 to 20 carbon atoms, Q_1 represents a single bond, -O-, -NH-, -NHCOO-, -OCONH-, -CH=CH-, -CO-, -COO-, -OCO-, -OCOO-, -OOCO-, -CH=CH-, -CH=CH-COO-, -OCO-CH=CH-, or -C≡C-, n_1 and n_2 each represent 1, 2, or 3, MG represents a mesogenic group or a mesogeneity supporting group, R_3 represents a halogen atom, a cyano group, or an alkyl group having 1 to 25 carbon atoms, at least one CH_2 group in the alkyl group may be substituted by -O-, -S-, -NH-, -N(CH₃)-, -CO-, -COO-, -OCO-, -OCOO-, -SCO-, -COS-, or -C≡C- so that oxygen atoms are not directly adjacent to each other, and alternatively R_3 represents $P_2-SP_2-Q_2$ (wherein P_2 , Sp_2 , and Q_2 independently represent the same meanings as P_1 , Sp_1 , and Q_1 , respectively).

[0049] In the general formula (PC1), MG is more preferably represented by the following structure,

[0050]

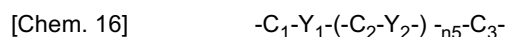

[0051] (in the formula, C_1 to C_3 each independently represent a 1, 4-phenylene group, a 1, 4-cyclohexylene group, a 1, 4-cyclohexenyl group, a tetrahydropyran-2, 5-diyl group, a 1, 3-dioxane-2, 5-diyl group, a tetrahydrothiopyran-2, 5-diyl group, a 1, 4-bicyclo(2, 2, 2) octylene group, a decahydronaphthalene-2, 6-diyl group, a pyridine-2, 5-diyl group, a pyrimidine-2, 5-diyl group, a pyrazine-2, 5-diyl group, a 1, 2, 3, 4-tetrahydronaphthalene-2, 6-diyl group, a 2, 6-naphthylene group, a phenanthrene-2, 7-diyl group, a 9, 10-dihydrophenanthrene-2, 7-diyl group, a 1, 2, 3, 4, 4a, 9, 10a-octahydrophenanthrene-2, 7-diyl group, or a fluorene-2, 7-diyl group, the 1, 4-phenylene group, 1, 2, 3, 4-tetrahydronaphthalene-2, 6-diyl group, 2, 6-naphthylene group, phenanthrene-2, 7-diyl group, 9, 10-dihydrophenanthrene-2, 7-diyl group, 1, 2, 3, 4, 4a, 9, 10a-octahydrophenanthrene-2, 7-diyl group, and fluorene-2, 7-diyl group may have as a substituent at least one F, Cl, CF₃, OCF₃, cyano group, alkyl group having 1 to 8 carbon atoms, alkoxy group, alkanoyl group, alkanoyloxy group, alkenyl group having 2 to 8 carbon atoms, alkenyloxy group, alkenoyl group, or alkenoyloxy group, Y_1 and Y_2 each independently represent -COO-, -OCO-, -CH₂CH₂-, -OCH₂-, -CH₂O-, -CH=CH-, -C≡C-, -CH=CHCOO-, -OCOCH=CH-, -CH₂CH₂COO-, -CH₂CH₂OCO-, -COOCH₂CH₂-, -OCOCH₂CH₂-, -CONH-, -NHCO-, or a single bond, and n_5 represents 0, 1, or 2), Sp_1 and Sp_1 each independently represent an alkylene group, the alkylene group may be substituted by at least one halogen atom or cyano group, at least one CH_2 group in the alkylene group may be substituted by -O-, -S-, -NH-, -N(CH₃)-, -CO-, -COO-, -OCO-, -OCOO-, -SCO-, -COS-, or -C≡C- so that oxygen atoms are not directly adjacent to each other, and P_1 and P_2 each independently represent a structure selected from the group consisting of compounds represented by general formula (PC1-a) to general formula (PC1-d) below,

[0052]

[Chem. 17]

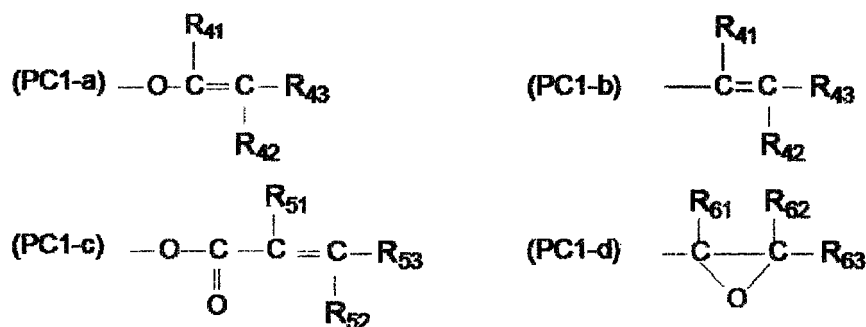

[0053] (in the formulae, R_{41} to R_{43} , R_{51} to R_{53} , and R_{61} to R_{63} each independently represent a hydrogen atom, a halogen atom, or an alkyl group having 1 to 5 carbon atoms).

[0054] More specifically, the general formula (PC1) is preferably a polymerizable compound represented by general

formula (PC1) -1 or general formula (PC1) -2,

[0055]

[Chem. 18]

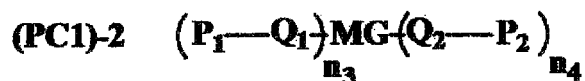
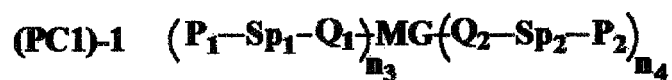

[0056] $(P_1, SP_1, Q_1, P_2, SP_2, Q_2$ and MG represent the same meanings as in the general formula (PC1), and n_3 and n_4 each independently represent 1, 2, or 3).

[0057] More specifically, the general formula (PC1) is preferably at least one polymerizable compound selected from the group consisting of compounds represented by general formula (PC1) -3 to general formula (PC1) -11,

[0058]

[Chem. 19]

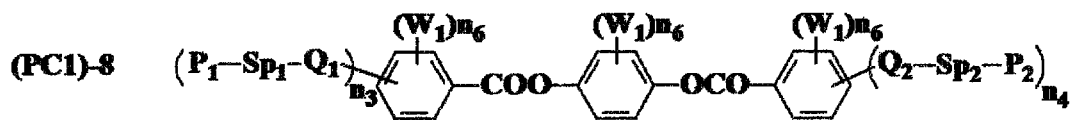
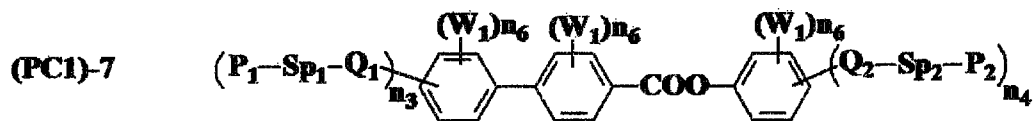
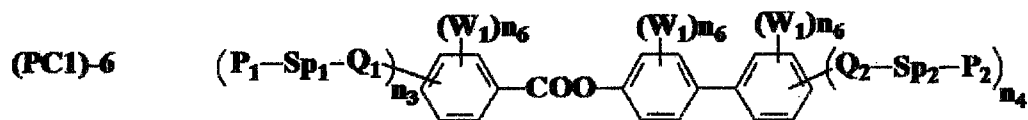
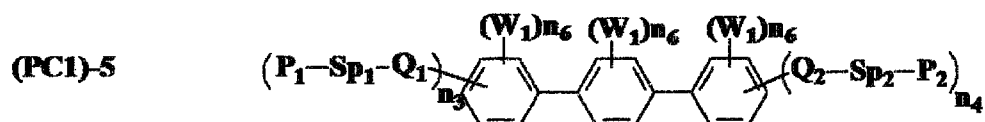
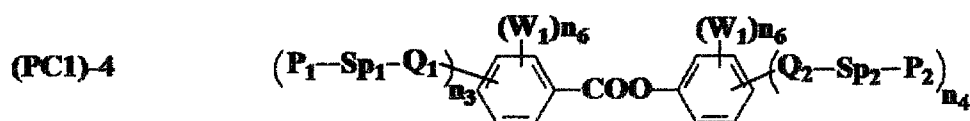
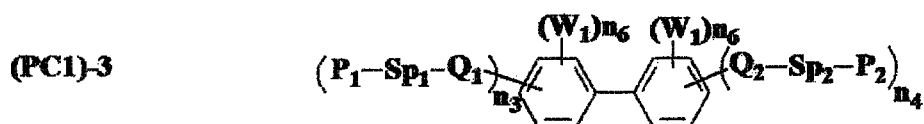

[0059]

[Chem. 20]

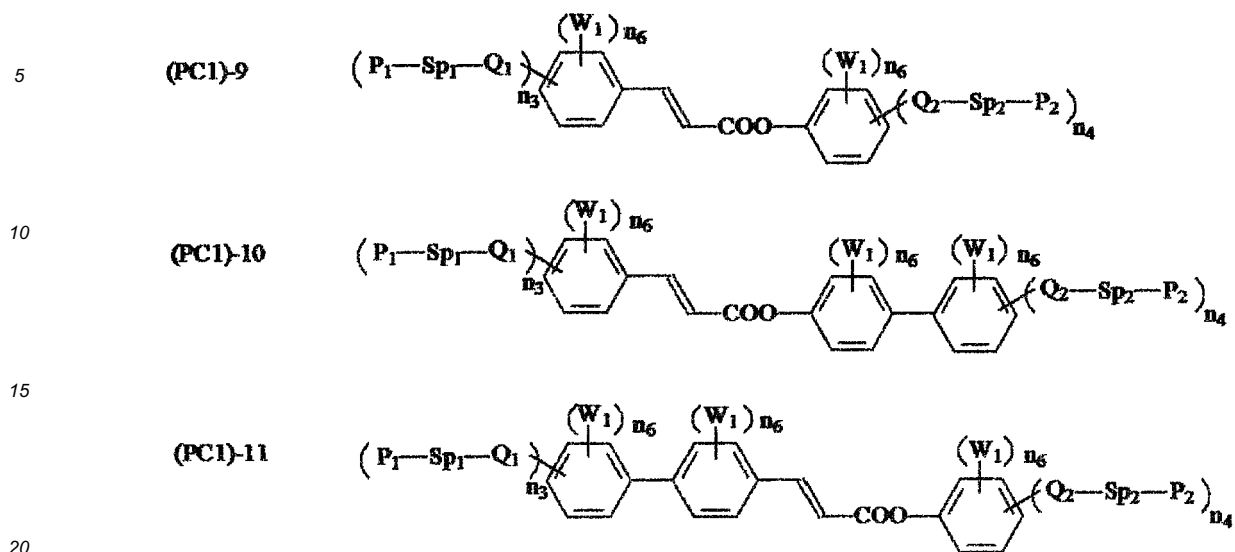

[0060] (in the formula, P_1 , P_2 , Sp_1 , Sp_2 , Q_1 , and Q_2 represent the same meanings as in the general formula (PC1), W_1 each independently represent F, CF_3 , OCF_3 , CH_3 , OCH_3 , an alkyl group having 2 to 5 carbon atoms, an alkoxy group, an alkenyl group, $COOW_2$, $OCOW_2$, or $OCOOW_2$ (wherein W_2 each independently represent a linear or branched alkyl group having 1 to 10 carbon atoms or an alkenyl group having 2 to 5 carbon atoms), n_3 each independently represent 1, 2, or 3, n_4 each independently represent 1, 2, or 3, n_6 each independently represent 0, 1, 2, 3, or 4, and $n_3 + n_6$ on the same ring and $n_4 + n_6$ on the same ring are 5 or less).

[0061] In the general formula (PC1) and the general formula (PC1) -1 to general formula (PC1) -11, Sp_1 , Sp_2 , Q_1 , and Q_2 are preferably single bonds. $n_3 + n_4$ is preferably to 3 and preferably 1 or 2. P_1 and P_2 are preferably formula (7-b). W_1 is preferably F, CF_3 , OCF_3 , CH_3 , or OCH_3 . n_6 is 1, 2, 3, or 4.

[0062] Specifically, the following compounds are preferred.

[0063]

[Chem. 21]

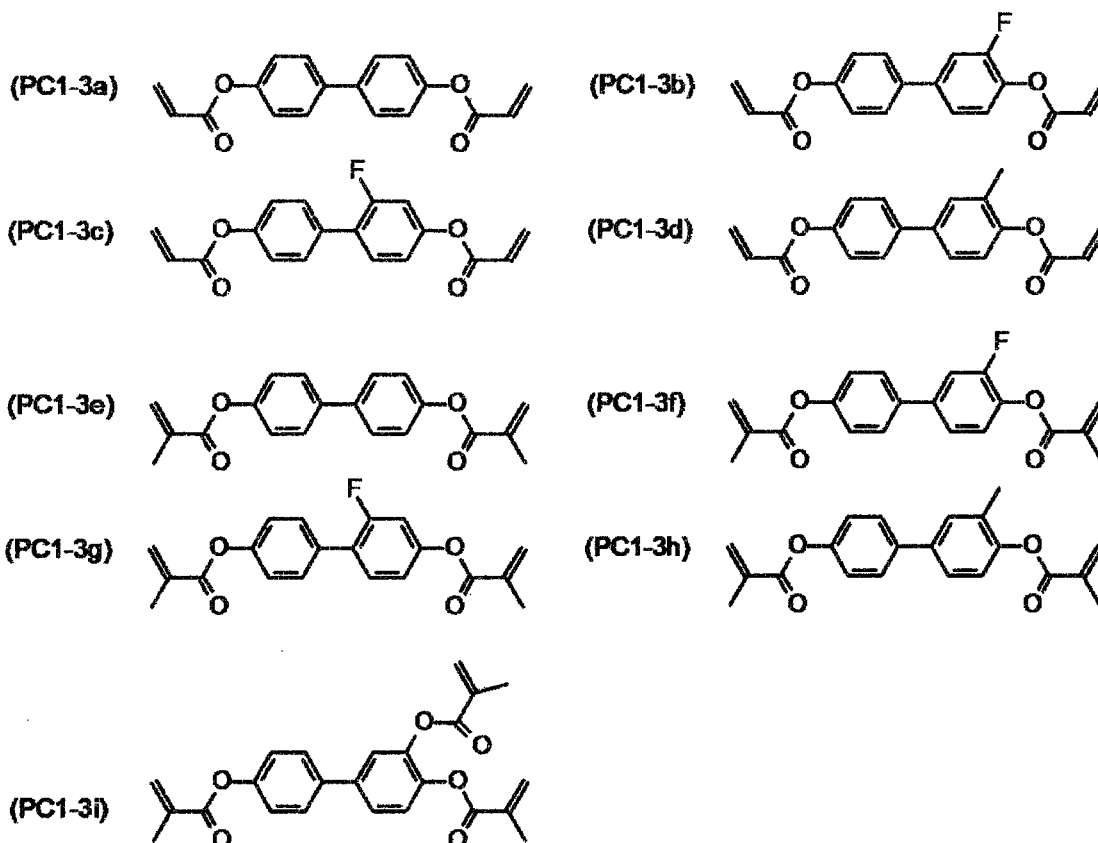

[0064] Further, a hydrogen atom in a benzene ring of (PC1-3a) to (PC1-3i) may be substituted by a fluorine atom.

[0065] Also, MG in the general formula (PC1) is preferably a disk-shaped liquid crystal compound represented by general formula (PC1) -9,

[0066]

[Chem. 22]

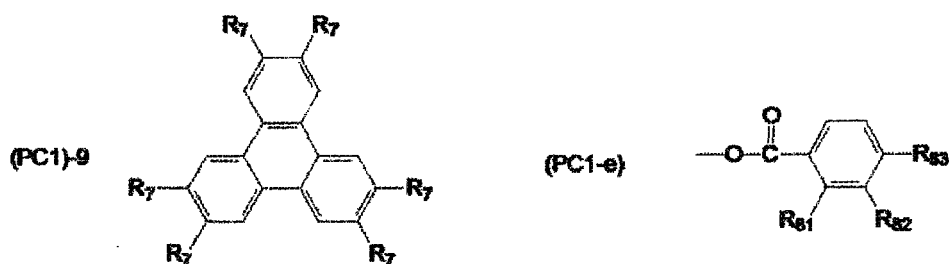

[0067] (in the formula, R_7 each independently represent a substituent represented by P_1 - Sp_1 - Q_1 or general formula (PC1-e) (wherein P_1 , Sp_1 , and Q_1 represent the same meanings as in the general formula (PC1), R_{81} and R_{82} each independently represent a hydrogen atom, a halogen atom, or a methyl group, R_{83} represents an alkoxy group having 1 to 20 carbon atoms, and at least one hydrogen atom in the alkoxy group is substituted by a substituent represented by the general formula (PC1-a) to (PC1-d)).

[0068] The amount of the polymerizable compound used is preferably 0.05 to 2.0% by mass.

The liquid crystal composition can be singly used for the above-described applications, and can further contain at least one antioxidant and at least one UV absorbent.

(Color filter)

[0069] A color filter according to the present invention includes a black matrix and at least RGB three-color pixel

portions, the RGB three-color pixel portions including, as colorants, a diketopyrrolopyrrole pigment and/or anionic red organic dye in a R pixel portion, at least one selected from the group consisting of a halogenated copper phthalocyanine pigment, a phthalocyanine green dye, and a mixture of a phthalocyanine blue dye and an azo yellow organic dye in a G pixel portion, and a ϵ -type copper phthalocyanine pigment and/or cationic blue organic dye in a B pixel portion.

5 **[0070]** The RGB three-color pixel portions preferably include, as colorants, C. I. Solvent Red 124 in the R pixel portion, a mixture of C. I. Solvent Blue 67 and C. I. Solvent Yellow 162 in the G pixel portion, and C. I. Solvent Blue 7 in the B pixel portion.

[0071] Also, the RGB three-color pixel portions preferably include, as colorants, C. I. Pigment Red 254 in the R pixel portion, C. I. Pigment Green 7 and/or 36 in the G pixel portion, and C. I. Pigment Blue 15:6 in the B pixel portion.

10 **[0072]** The RGB three-color pixel portions preferably further include, as a colorant in the R pixel portion, at least one organic dye/pigment selected from the group consisting of C. I. Pigment Red 177, 242, 166, 167, and 179, C. I. Pigment Orange 38 and 71, C. I. Pigment Yellow 150, 215, 185, 138, and 139, C. I. Solvent Red 89, C. I. Solvent Orange 56, and C. I. Solvent Yellow 21, 82, 83:1, 33, and 162.

15 **[0073]** The RGB three-color pixel portions preferably include, as a colorant in the G pixel portion, at least one organic dye/pigment selected from the group consisting of C. I. Pigment Yellow 150, 215, 185, and 138, and C. I. Solvent Yellow 21, 82, 83:1, and 33.

[0074] The RGB three-color pixel portions preferably further include, as a colorant in the B pixel portion, at least one organic dye/pigment selected from the group consisting of C. I. Pigment Blue 1, C. I. Pigment Violet 23, C. I. Basic Blue 7, C. I. Basic Violet 10, C. I. Acid Blue 1, 90, and 83, and C. I. Direct Blue 86.

20 **[0075]** Also, the color filter includes a black matrix, RGB three-color pixel portions, and a Y pixel portion, and preferably contains, as a colorant in the Y pixel portion, at least one yellow organic dye/pigment selected from the group consisting of C. I. Pigment Yellow 150, 215, 185, 138, and 139, and C. I. Solvent Yellow 21, 82, 83:1, 33, and 162.

25 **[0076]** In the color filter, the color filter pixel portions can be formed by a generally known method. A typical method for forming pixel portions is a photolithography method in which a photocurable composition described below is applied to a surface of a color filter transparent substrate on the side provided with a black matrix and then dried by heating (prebaked), the photocurable compound is cured in portions corresponding to the pixel portions by pattern exposure under irradiation with ultraviolet light through a photomask, unexposed portions are developed with a developer, and then non-pixel portions are removed to fix the pixel portions to the transparent substrate. This method forms the pixel portions each composed of a cured color film of the photocurable composition on the transparent substrate.

30 **[0077]** A photocurable composition described below is prepared for each of R pixels, G pixels, B pixels, and if required, other color pixels such as Y pixels or the like, and the above-described operation is repeated to produce a color filter having color pixel portions of the R pixels, G pixels, B pixels, and Y pixels at predetermined positions.

Examples of a method for applying each photocurable composition described below to the transparent substrate of glass or the like include a spin coating method, a roll coating method, an ink jet method, and the like.

35 The drying conditions of a coating film of the photocurable composition applied to the transparent substrate are generally 50°C to 150°C and about 1 to 15 minutes, depending on the type and mixing ratio of each component, or the like. Light used for photocuring the photocurable composition is preferably ultraviolet light within a wavelength range of 200 to 500 nm or visible light. Various light sources which emit light within this wavelength range can be used.

40 Examples of a development method include a puddle method, a dipping method, a spray method, and the like. After exposure and development of the photocurable composition, the transparent substrate on which necessary color pixel portions have been formed is washed with water and dried. The resultant color filter is heat-treated (post baked) at 90°C to 280°C for a predetermined time using a heating apparatus such as a hot plate, an oven, or the like to remove volatile components in the color coating film and, at the same time, to heat-cure an unreacted photocurable compound remaining in the cured color coating film of the photocurable composition, completing the color filter.

45 **[0078]** By using the colorants for the color filter of the present invention in combination with the liquid crystal composition of the present invention, it is possible to provide a liquid crystal display device capable of preventing a decrease in voltage holding ratio (VHR) of the liquid crystal layer and an increase in ion density (ID) and resolving the problems of display defects such as white spots, alignment unevenness, image sticking, and the like.

50 A method for producing the photocurable composition is generally a method in which a dye and/or pigment composition for the color filter of the present invention, an organic solvent, and a dispersant are used as essential components, these components are mixed and uniformly dispersed by stirring to prepare a pigment dispersion for forming a pixel portion of the color filter, and a photocurable compound and, if required, a thermoplastic resin, a photopolymerization initiator, and the like are added to the dispersion to produce the photocurable composition.

55 **[0079]** Examples of the organic solvent used include aromatic solvents such as toluene, xylene, methoxybenzene, and the like; acetic acid ester solvents such as ethyl acetate, propyl acetate, butyl acetate, propylene glycol monomethyl ether acetate, propylene glycol monoethyl ether acetate, diethylene glycol methyl ether acetate, diethylene glycol ethyl ether acetate, diethylene glycol propyl ether acetate, diethylene glycol butyl ether acetate, and the like; propionate solvents such as ethoxyethyl propionate, and the like; alcohol solvents such as methanol, ethanol, and the like; ether

solvents such as butyl cellosolve, propylene glycol monomethyl ether, diethylene glycol ethyl ether, diethylene glycol dimethyl ether, and the like; ketone solvents such as methyl ethyl ketone, methyl isobutyl ketone, cyclohexanone, and the like; aliphatic hydrocarbon solvents such as hexane and the like; nitrogen compound solvents such as N, N-dimethylformamide, γ -butyrolactam, N-methyl-2-pyrrolidone, aniline, pyridine, and the like; lactone solvents such as γ -butyrolactone and the like; and carbamic acid esters such as a mixture of methyl carbamate and ethyl carbamate at 48:52, and the like.

[0080] Examples of the dispersant which can be used include dispersants such as BYK Chemie DISPERBYK 130, DISPERBYK 161, DISPERBYK 162, DISPERBYK 163, DISPERBYK 170, DISPERBYK 171, DISPERBYK 174, DISPERBYK 180, DISPERBYK 182, DISPERBYK 183, DISPERBYK 184, DISPERBYK 185, DISPERBYK 2000, DISPERBYK 2001, DISPERBYK 2020, DISPERBYK 2050, DISPERBYK 2070, DISPERBYK 2096, DISPERBYK 2150, DISPERBYK LPN21116, and DISPERBYK LPN6919; Efka Chemicals Company Efka 46, Efka 47, Efka 452, Efka LP4008, Efka 4009, Efka LP4010, Efka LP4050 and LP4055, Efka 400, Efka 401, Efka 402, Efka 403, Efka 450, Efka 451, Efka 453, Efka 4540, Efka 4550, Efka LP4560, Efka 120, Efka 150, Efka 1501, Efka 1502, and Efka 1503; Lubrizol Corporation Solsperse 3000, Solsperse 9000, Solsperse 13240, Solsperse 13650, Solsperse 15940, Solsperse 17000 and 1.8000, Solsperse 20000, Solsperse 21000, Solsperse 20000, Solsperse 24000, Solsperse 26000, Solsperse 27000, Solsperse 28000, Solsperse 32000, Solsperse 36000, Solsperse 37000, Solsperse 38000, Solsperse 41000, Solsperse 42000, Solsperse 43000, Solsperse 46000, Solsperse 54000, and Solsperse 71000; and Ajimonoto Co., Ltd. Ajisper PB711, Ajisper PB821, Ajisper PB822, Ajisper PB814, Ajisper PN411, and Ajisper PA111; and synthetic resins which are liquid at room temperature and water-insoluble, such as acryl resins, urethane resins, alkyd resins, natural rosins such as wood rosin, gum rosin, tall oil rosin, and the like, modified rosins such as polymerized rosin, disproportionated rosin, hydrogenated rosin, oxidized rosin, maleinized rosin, and the like, rosin derivatives such as rosin amine, lime rosin, rosin alkyleneoxide adduct, rosin alkyd adduct, rosin-modified phenol, and the like. Addition of any one of the dispersants and resins contributes to a decrease in flocculation and improvements in dispersion stability of pigments and viscosity characteristics of the dispersant.

[0081] Examples of a dispersion aid which can be used include organic pigment derivatives such as phthalimide methyl derivatives, sulfonic acid derivatives, N-(dialkylamino) methyl derivative, N-(dialkylaminoalkyl) sulfonic amide derivatives, and the like. Of course, these derivatives can be used in combination of two or more different types.

Examples of the thermoplastic resin used for preparing the photocurable composition include urethane resins, acryl resins, polyamide resins, polyimide resins, styrene-maleic acid resins, styrene-maleic anhydride resins, and the like.

Examples of the photocurable compound include difunctional monomers such as 1, 6-hexanediol diacrylate, ethylene glycol diacrylate, neopentyl glycol diacrylate, triethylene glycol diacrylate, bis(acryloxyethoxy) bisphenol A, 3-methylpentanediol diacrylate, and the like; polyfunctional monomers with relatively low molecular weight, such as trimethylolpropane triacrylate, pentaerythritol triacrylate, tris [2-(meth) acryloyloxyethyl] isocyanurate, dipentaerythritol hexaacrylate, dipentaerythritol pentaacrylate, and the like; and polyfunctional monomers with relatively high molecular weight, such as polyester acrylate, polyurethane acrylate, polyether acrylate, and the like.

Examples of the photopolymerization initiator include acetophenone, benzophenone, benzyl dimethyl ketal, benzoyl peroxide, 2-chlorothioxanthone, 1, 3-bis(4'-azidobenzal) -2-propane, 1, 3-bis(4'-azidobenzal) -2-propane-2'-sulfonic acid, 4, 4'-diazidostilbene-2, 2'-disulfonic acid, and the like. Examples of a commercially available photopolymerization initiator include BASF Corporation "Irgacure (trade name) -184", "Irgacure (trade name) -369", "Darocur (trade name) -1173", and BASF Corporation "Lucirin-TPO", Nippon Kayaku Co., Ltd. "Kayacure (trade name) DETX" and "Kayacure (trade name) OA", Sutoufa Chemical Co., "Baikyua 10" and "Baikyua 55", Akzo Co., Ltd. "Trigonal PI", Sandozu Co., Ltd. "Sandorei 1000", Apujon Co., Ltd. "Deep", Kurogane Kasei Co., Ltd. "Biimidazole", and the like.

[0082] The photopolymerization initiator can be combined with a known photosensitizer in common use. Examples of the photosensitizer include amines, ureas, sulfur atom-containing compounds, phosphorus atom-containing compounds, chlorine atom-containing compounds, nitriles, other nitrogen atom-containing compounds, and the like. These can be used alone or in combination of two or more.

[0083] The ratio of the photopolymerization initiator mixed is not particularly limited but is preferably in a range of 0.1% to 30% on a mass basis relative to a compound having a photopolymerizable or photocurable functional group. With the ratio less than 0.1%, sensitivity during curing tends to be decreased, while with the ratio exceeding 30%, crystals of the photopolymerization initiator may be precipitated when a coating film of a pigment-dispersed resist is dried, thereby causing deterioration in the physical properties of the coating film.

By using each of the above-described materials, on a mass basis, 300 to 1000 parts of the organic solvent and 1 to 100 parts of the dispersant relative to 100 parts of the color filter dye and/or pigment composition of the present invention are uniformly dispersed by stirring to prepare the dye/pigment solution. Then, to the pigment dispersion, the thermoplastic resin and the photocurable compound in a total of 3 to 20 parts per part of the pigment composition for the color filter of the present invention, 0.05 to 3 parts of the photopolymerization initiator per part of the photocurable compound, and if required, the organic solvent are added and uniformly dispersed by stirring to produce the photocurable composition for forming each of the color filter pixel portions.

[0084] A known organic solvent or aqueous alkali solution in common use can be used as the developer. In particular, when the photocurable composition contains the thermoplastic resin or the photocurable compound at least one of which has an acid value and exhibits alkali solubility, washing with an aqueous alkali solution is effective for forming the color filter pixel portions.

Although the method for producing the color filter pixel portions by the photolithography method is described in detail, each of the color filter pixel portions prepared by using the color filter pigment composition of the present invention may be formed by another method such as an electrodeposition method, a transfer method, a micelle electrolysis method, a PVED (Photovoltaic Electrodeposition) method, an ink jet method, a reverse printing method, a heat curing method, or the like, thereby producing the color filter.

(Alignment film)

[0085] In the liquid crystal display device of the present invention, when the alignment film for aligning the liquid crystal composition is required to be provided on the surface of each of the first and second substrates which is in contact with the liquid crystal composition, the alignment film is disposed between the color filter and the liquid crystal layer. However, even in the case of a thick film, the alignment film has a thickness of as small as 100 nm or less so as not to completely cut off the interaction between the colorants such as pigments or the like, which constitute the color filter, and the liquid crystal compound constituting the liquid crystal layer.

The liquid crystal display device without using the alignment film has greater interaction between the colorants such as pigments or the like, which constitute the color filter, and the liquid crystal compound constituting the liquid crystal layer.

[0086] Usable examples of an alignment film material include transparent organic materials such as polyimide, polyamide, BCB (benzocyclobutene polymer), polyvinyl alcohol, and the like. In particular, it is preferred to use a polyimide alignment film produced by imidizing a polyamic-acid synthesized from diamine such as an aliphatic or alicyclic diamine, for example, p-phenylenediamine, 4, 4'-diaminodiphenylmethane, or the like, and an aliphatic or alicyclic tetracarboxylic anhydride, such as butanetetracarboxylic anhydride, 2, 3, 5-tricarboxycyclopentylacetic anhydride, or the like, or an aromatic tetracarboxylic anhydride such as pyromellitic dianhydride or the like. In this case, rubbing is generally used as an alignment imparting method, but when the alignment film is used as a vertical alignment film, it can be used without imparting alignment.

A material containing a compound containing chalcone, cinnamate, cinnamoyl, or an azo group can be used as the alignment film material, and this may be used in combination with a material such as polyimide, polyamide, or the like. For this alignment film, rubbing may be used or a light alignment technique may be used.

The alignment film is generally formed as a resin film by applying the alignment film material to the substrate using a method such as a spin coating method or the like, but a uniaxial stretching method, a Langmuir-Blodgett method, or the like can also be used.

(Transparent electrode)

[0087] In the liquid crystal display device of the present invention, a conductive metal oxide can be used as a material of the transparent electrode. Usable examples of the metal oxide include indium oxide (In_2O_3), tin oxide (SnO_2), zinc oxide (ZnO), indium-tin oxide ($\text{In}_2\text{O}_3\text{-SnO}_2$), indium-zinc oxide ($\text{In}_2\text{O}_3\text{-ZnO}$), niobium-added titanium dioxide ($\text{Ti}_{1-x}\text{Nb}_x\text{O}_2$), fluorine-doped tin oxide, graphene nanoribbons or metal nanowires, and the like. But zinc oxide (ZnO), indium-tin oxide ($\text{In}_2\text{O}_3\text{-SnO}_2$), or indium-zinc oxide ($\text{In}_2\text{O}_3\text{-ZnO}$) is preferred. The transparent conductive film can be patterned by a method such as a photo-etching method, a method using a mask, or the like.

[0088] The liquid crystal layer of the present invention is useful for a liquid crystal display device, particularly a liquid crystal display device for active matrix driving, and can be used for a liquid crystal display device for a VA mode, an IPS mode, or an ECB mode.

The liquid crystal layer containing the polymerizable monomer according to the present invention, for example, the liquid crystal layer used for a PSA mode and a PSVA mode, is imparted with the liquid crystal alignment ability when the polymerizable monomer contained is polymerized by ultraviolet irradiation, and is used for a liquid crystal display device in which a quantity of transmitted light is controlled by using birefringence of the liquid crystal composition. The liquid crystal layer is useful for AM-LCD (active matrix liquid crystal display device), TN (nematic liquid crystal display device), STN-LCD (super-twisted nematic liquid crystal display device), OCB-LCD and IPS-LCD (in-plane switching liquid crystal display device), particularly useful for AM-LCD, and can be used for a transmissive or reflective liquid crystal display device.

[0089] The liquid crystal display device of the present invention is used in combination with a backlight for various applications such as a liquid crystal television, a monitor of a personal computer, a cellular phone, a display of a smart phone, a notebook-size personal computer, a portable information terminal, a digital signage, and the like. Examples of the backlight include a cold-cathode tube-type backlight, a two-wavelength-peak pseudo-white backlight and three-wave-

length-peak backlight each using a light-emitting diode using an inorganic material or an organic EL element, and the like.

EXAMPLES

5 **[0090]** A best mode of the present invention is partially described in detail below by way of examples, but the present invention is not limited to these examples. In the examples and comparative examples below, "%" in a composition represents "% by mass".

[0091] The physical properties of a liquid crystal composition are represented as follows.

T_{N-I} : nematic-isotropic liquid phase transition temperature (°C) as liquid crystal phase upper limit temperature

10 $\Delta\epsilon$: dielectric constant anisotropy

Δn : refractive index anisotropy

η : viscosity at 20°C (mPa·s)

d_{gap} : gap between first substrate and second substrate of cell (μm)

VHR: voltage holding ratio at 70°C (%)

15 (a value by % representing a ratio of a measured voltage to an initial applied voltage, the measured voltage being measured using a liquid crystal composition injected into a cell having a cell thickness of 3.5 μm under the conditions of 5 V applied, a frame time of 200 ms, and a pulse width of 64 μs)

ID: ion density at 70°C (pC/cm^2)

20 (a value of ion density measured using a liquid crystal composition injected into a cell having a cell thickness of 3.5 μm and MTR-1 (manufactured by Toyo Corporation) under the conditions of 20 V applied and a frequency of 0.05 Hz)

Compounds are represented by abbreviations below.

[0092]

25	n (Number) at end $\text{C}_n\text{H}_{2n+1}$ -
	-2- - CH_2CH_2 -
	-10- - CH_2O -
	-01- - OCH_2 -
	-0n - $\text{OC}_n\text{H}_{2n+1}$
30	-1=1- - $\text{HC}=\text{CH}$ -
	-V0- - C00 -
	ndm- $\text{C}_n\text{H}_{2n+1}\text{-HC}=\text{CH}(\text{CH}_2)_{m-1}$ -

35 **[0093]**

[Chem. 23]

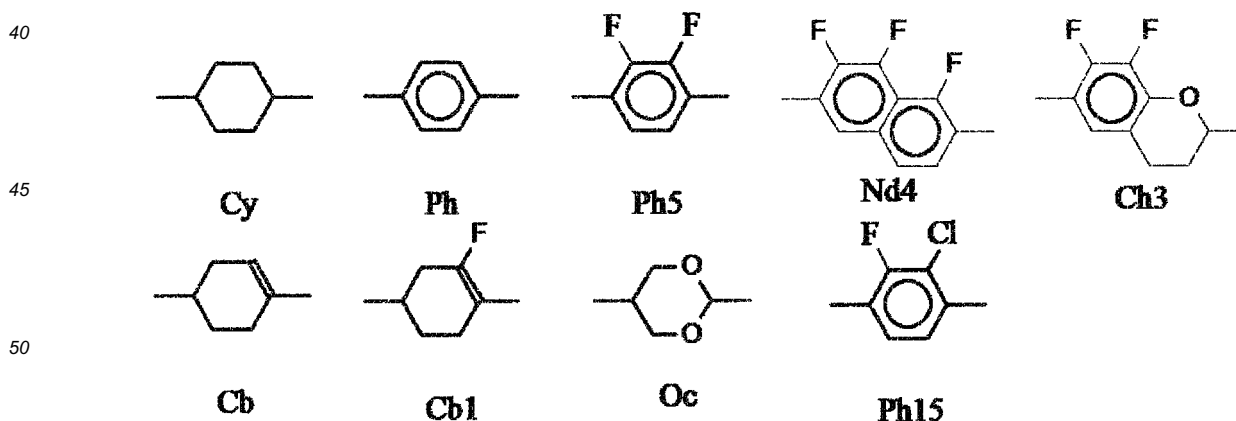

55 **[0094]** Image sticking of the liquid crystal display device was evaluated by display of a predetermined fixed pattern within a display area for 1000 hours and then uniform display over the entire screen to visually observe the level of residual image of the fixed pattern based on the following 4 levels:

[0095]

EP 2 657 754 A1

- A: No residual image
- B: Slight residual image at an allowable level
- C: Residual image at an unallowable level
- D: Significant residual image

5

[Formation of color filter]

[Preparation of colored composition]

10

[Red dye colored composition 1]

15

[0096] In a polymer bottle, 10 parts of red dye 1 (C. I. Solvent Red 124) was placed, and 55 parts of propylene glycol monomethyl ether acetate and SEPR beads of 0.3 to 0.4 mm in diameter were added, and the resultant mixture was dispersed with a paint conditioner (manufactured by Toyo Seiki Co., Ltd.) for 4 hours and then filtered with a 5 μm filter to produce a dye colored solution. Then, 75.00 parts of the dye colored solution, 5.50 parts of polyester acrylate resin (Aronix (trade name) M7100 manufactured by Toa Gosei Chemical Industry Co., Ltd.), 5.00 parts of dipentaerythritol hexaacrylate (KAYARAD (trade name) DPHA, manufactured by Nippon Kayaku Co., Ltd.), 1.00 part of benzophenone (KAYACURE (trade name) BP-100, manufactured by Nippon Kayaku Co., Ltd.), and 13.5 parts of Ucar Ester EEP were stirred with a dispersion stirrer and then filtered with a filter having a pore size of 1.0 μm to produce red dye colored composition 1.

20

[Red dye colored composition 2]

25

[0097] Red dye colored composition 2 was produced by the same method as described above using 8 parts of the red dye 1 (C. I. Solvent Red 124) and 2 parts of yellow dye 2 (C. I. Solvent Yellow 21) in place of 10 parts of the red dye 1 of the red dye colored composition 1.

[Red dye colored composition 3]

30

[0098] Red dye colored composition 3 was produced by the same method as described above using 10 parts of red dye 2 (C. I. Solvent Red 1) in place of 10 parts of the red dye 1 of the red dye colored composition 1.

[Green dye colored composition 1]

35

[0099] Green dye colored composition 1 was produced by the same method as described above using 3 parts of blue dye 1 (C. I. Solvent Blue 67) and 7 parts of yellow dye 1 (C. I. Solvent Yellow 162) in place of 10 parts of the red dye 1 of the red dye colored composition 1.

[Green dye colored composition 2]

40

[0100] Green dye colored composition 2 was produced by the same method as described above using 4 parts of the yellow dye 1 (C. I. Solvent Yellow 162) and 3 parts of yellow dye 3 (C.I. Solvent Yellow 82) in place of 7 parts of the yellow dye 1 of the green dye colored composition 1.

45

[Green dye colored composition 3]

[0101] Green dye colored composition 3 was produced by the same method as described above using 10 parts of green dye 1 (C. I. Solvent Green 7) in place of 3 parts of the blue dye 1 and 7 parts of the yellow dye 1 of the green dye colored composition 1.

50

[Blue dye colored composition 1]

[0102] Blue dye colored composition 1 was produced by the same method as described above using 10 parts of the blue dye 1 (C. I. Solvent Blue 7) in place of 10 parts of the red dye 1 of the red dye colored composition 1.

55

[Blue dye colored composition 2]

[0103] Blue dye colored composition 2 was produced by the same method as described above using 7 parts of the

EP 2 657 754 A1

blue dye 1 (C. I. Solvent Blue 7) and 3 parts of violet dye 1 (C. I. Basic Violet 10) in place of 10 parts of the blue dye 1 of the blue dye colored composition 1.

[Blue dye colored composition 3]

5

[0104] Blue dye colored composition 3 was produced by the same method as described above using 10 parts of blue dye 2 (C. I. Solvent Blue 12) in place of 7 parts of the blue dye 1 and 3 parts of the violet dye 1 of the blue dye colored composition 2.

10 [Yellow dye colored composition 1]

[0105] Yellow dye colored composition 1 was produced by the same method as described above using 10 parts of yellow dye 2 (C. I. Solvent Yellow 21) in place of 10 parts of the red dye 1 of the red dye colored composition 1.

15 [Yellow dye colored composition 2]

[0106] Yellow dye colored composition 2 was produced by the same method as described above using 10 parts of yellow dye 4 (C. I. Solvent Yellow 2) in place of 10 parts of the yellow dye 2 of the yellow dye colored composition 1.

20 [Red pigment colored composition 1]

[0107] In a polymer bottle, 10 parts of red pigment 1 (C. I. Pigment Red 254, "IRGAPHOR RED BT-CF" manufactured by BASF Corporation) was placed, and 55 parts of propylene glycol monomethyl ether acetate, 7.0 parts of DISPERBYK LPN21116 (manufactured by BYK Chemie Corporation), and SEPR beads of 0.3 to 0.4 mm in diameter were added, and the resultant mixture was dispersed with a paint conditioner (manufactured by Toyo Seiki Co., Ltd.) for 4 hours and then filtered with a 5 μm filter to produce a pigment-dispersed solution. Then, 75.00 parts of the pigment-dispersed solution, 5.50 parts by polyester acrylate resin (Aronix (trade name) M7100 manufactured by Toa Gosei Chemical Industry Co., Ltd.), 5.00 parts of dipentaerythritol hexaacrylate (KAYARAD (trade name) DPHA, manufactured by Nippon Kayaku Co., Ltd.), 1.00 part of benzophenone (KAYACURE (trade name) BP-100, manufactured by Nippon Kayaku Co., Ltd.), and 13.5 parts of Ucar Ester EEP were stirred with a dispersion stirrer and then filtered with a filter having a pore size of 1.0 μm to produce red pigment colored composition 1.

25

30

[Red pigment colored composition 2]

[0108] Red pigment colored composition 2 was produced by the same method as described above using 6 parts of the red pigment 1, 2 parts of red pigment 2 (C. I. Pigment Red 177 manufactured by DIC Corporation, FASTOGEN SUPER RED ATY-TR), and 2 parts of yellow pigment 2 (C. I. Pigment Yellow 139) in place of 10 parts of the red pigment 1 of the red pigment colored composition 1.

40 [Green pigment colored composition 1]

[0109] Green pigment colored composition 1 was produced by the same method as described above using 6 parts of green pigment 1 (C. I. Pigment Green 36, manufactured by DIC Corporation, "FASTOGEN GREEN 2YK-CF"), and 4 parts of yellow pigment 1 (C. I. Pigment Yellow 150, manufactured by BAYER Corporation, FANCHON FAST YELLOW E4GN) in place of 10 parts of the red pigment 1 of the red pigment colored composition 1.

45

[Green pigment colored composition 2]

[0110] Green pigment colored composition 2 was produced by the same method as described above using 4 parts of green pigment 2 (C. I. Pigment Green 7, manufactured by DIC Corporation, FASTOGEN GREEN S) and 6 parts of yellow pigment 3 (C. I. Pigment Yellow 138) in place of 6 parts of the green pigment 1 and 4 parts of the yellow pigment 1 of the green pigment colored composition 1.

50

[Blue pigment colored composition 1]

55

[0111] Blue pigment colored composition 1 was produced by the same method as described above using 9 parts of blue pigment 1 (C. I. Pigment Blue 15:6, manufactured by DIC Corporation, "FASTOGEN BLUE EP-210") and 1 part of violet pigment 1 (C. I. Pigment Violet 23) in place of 10 parts of the red pigment 1 of the red pigment colored composition 1.

[Blue pigment-dye colored composition 2]

[0112] Blue pigment-dye colored composition 2 was produced by the same method as described above using 1 part of violet dye 1 (C. I. Basic Violet 10) in place of 1 part of the violet pigment 1 of the blue pigment colored composition 1.

[Yellow pigment colored composition 1]

[0113] Yellow pigment colored composition 1 was produced by the same method as described above using 10 parts of yellow pigment 1 (C. I. Pigment Yellow 15, manufactured by BAYER Corporation, FANCHON FAST YELLOW E4GN) in place of 10 parts of the red pigment 1 of the red pigment colored composition 1.

[Formation of color filter]

[0114] The red colored composition was applied to a thickness of 2 μm by spin coating on a glass substrate on which a black matrix had been previously formed. After drying at 70°C for 20 minutes, stripe-shaped pattern exposure was performed with ultraviolet light through a photomask using an exposure apparatus provided with a super-high pressure mercury lamp. Then, spray development with an alkali developer for 90 seconds, washing with ion exchange water, and air drying were performed. Further, post baking was performed in a clean oven at 230°C for 30 minutes to form red pixels as a stripe-shaped color layer on the transparent substrate.

Next, similarly, the green colored composition was applied to a thickness of 2 μm by spin coating. After drying, a stripe-shaped color layer was formed in a position deviated from the red pixels by exposure with an exposure apparatus and development, thereby forming green pixels adjacent to the red pixels.

Next, similarly, the blue colored composition was applied to a thickness of 2 μm by spin coating, forming blue pixels adjacent to the red pixels and the green pixels. As a result, a color filter having stripe-shaped pixels of the three colors of red, green, and blue was produced.

If required, similarly, the yellow colored composition was applied to a thickness of 2 μm by spin coating, forming blue pixels adjacent to the red pixels and the green pixels. As a result, a color filter having stripe-shaped pixels of the four colors of red, green, blue, and yellow was produced.

Color filters 1 to 4 and comparative color filter 1 were formed by using the dye colored compositions or pigment colored compositions shown in Table 1.

[0115]

[Table 1]

	Color filter 1	Color filter 2	Color filter 3	Color filter 4	Comparative Color filter 1
R pixel portion	Red dye colored composition 1	Red dye colored composition 2	Red pigment colored composition 1	Red pigment colored composition 2	Red dye colored composition 3
G pixel portion	Green dye colored composition 1	Green dye colored composition 2	Green pigment colored composition 1	Green pigment colored composition 2	Green dye colored composition 3
B pixel portion	Blue dye colored composition 1	Blue dye colored composition 2	Blue pigment colored composition 1	Blue pigment-dye colored composition 2	Blue dye colored composition 3
Y pixel portion	No	Yellow dye colored composition 1	No	Yellow pigment colored composition 1	Yellow dye coloured composition 2

(EXAMPLES 1 to 4)

[0116] An electrode structure was formed on each of first and second substrates, and a vertical alignment-type alignment film was formed on each of the facing surfaces of the substrates and weakly rubbed to form a VA cell. Then, liquid crystal composition 1 having negative dielectric anisotropy and shown in Table 2 was held between the first substrate and the second substrate. Next, liquid crystal display devices of Example 1 were formed by using the color filters 1 to 4 shown in Table 1 ($d_{gap} = 3.5 \mu\text{m}$, alignment film SE-5300). VHR and ID of the resultant liquid crystal display

devices were measured. Also, image sticking of the resultant liquid crystal display devices was evaluated. The results are shown in Table 3.

[0117]

[Table 2]

	Liquid crystal composition
0d1-Cy-Cy-3	20
3-Cy-Cy-2	15
3-Cy-Ph-O1	5
0d1-Cy-10-Ph5-O1-Cy-2	11
0d1-Cy-10-Ph5-O1-Cy-3	11
0d1-Cy-10-Ph5-O1-Cy-4	11
0d1-Cy-10-Ph5-O1-Cy-5	11
0d1-Cy-Cy-10-Ph5-O3d0	4
0d1-Cy-Cy-10-Ph5-O4d0	4
0d1-Cy-10-Ph5-O1-Cy-Cy-2	4
0d1-Cy-10-Ph5-O1-Cy-Cy-3	4
Composition ratio total (%)	100
T_{ni}/°C	82.4
Δn(20°C)	0.074
η 20/mPa·s	16.1
Δε (20°C)	-4.7

[0118]

[Table 3]

	Example 1	Example 2	Example 3	Example 4
Liquid crystal composition	Liquid crystal composition 1	Liquid crystal composition 1	Liquid crystal composition 1	Liquid crystal composition 1
Color filter	Color filter 1	Color filter 2	Color filter 3	Color filter 4
VHR	99.1	99.0	99.5	99.4
ID	64	76	17	22
Image sticking	B	B	A	A

[0119] The liquid crystal display devices of Examples 1 to 4 could realize high VHR and small ID. Also, in evaluation of image sticking, no residual image or slight residual image at an allowable level was observed.

(COMPARATIVE EXAMPLES 1 to 8)

[0120] Each of comparative liquid crystal composition 1 and comparative liquid crystal composition 2 shown in Table 4 and having negative dielectric anisotropy was interposed in the VA cell used in Example 1, liquid crystal display devices of Comparative Examples 1 to 8 were formed by using the color filters 1 to 4 shown in Table 1, and VHR and ID of the resultant liquid crystal display devices were measured. Also, image sticking of the resultant liquid crystal display devices was evaluated. The results are shown in Table 5 and Table 6.

[0121]

[Table 4]

	Comparative liquid crystal composition 1	Comparative liquid crystal composition 2
5	0d1-Cy-Cy-3	20
	3-Cy-Cy-2	14
	3-Cy-Ph-O1	5
10	0d1-Cy-1O-Ph15-O1-Cy-2	8
	0d1-Cy-1O-Ph15-O1-Cy-3	8
	0d1-Cy-1O-Ph15-O1-Cy-4	10
15	0d1-Cy-1O-Ph15-O1-Cy-5	10
	0d1-Cy-Cy-1O-Ph15-O3d0	4
	0d1-Cy-Cy-1O-Ph15-O4d0	4
	0d1-Cy-1O-Ph15-O1-Cy-Cy-2	4
20	0d1-Cy-1O-Ph15-Cy-Cy-3	4
	3-Cy-Oc-Ph15-O1	8
	3-Cy-Cb1-Ph15-O2	
25	5-Cy-Cb1-Ph15-O2	
	5-Cy-Cb-Ph15-O2	
	Composition ratio total	100
	Tni/°C	81.3
30	$\Delta n(20^\circ\text{C})$	0.074
	η 20/mPa·s	16.8
	$\Delta \varepsilon(20^\circ\text{C})$	-4.7

35

[0122]

[Table 5]

	Comparative Example 1	Comparative Example 2	Comparative Example 3	Comparative Example 4
40	Liquid crystal composition	Comparative liquid crystal composition 1	Comparative liquid crystal composition 1	Comparative liquid crystal composition 1
	Color filter	Color filter 1	Color filter 2	Color filter 3
45	VHR	98.4	98.2	98.6
	ID	125	141	118
50	Image sticking	D	D	C
				D

50

[0123]

55

[Table 6]

	Comparative Example 5	Comparative Example 6	Comparative Example 7	Comparative Example 8
Liquid crystal composition	Comparative liquid crystal composition 2	Comparative liquid crystal composition 2	Comparative liquid crystal composition 2	Comparative liquid crystal composition 2
Color filter	Color filter 1	Color filter 2	Color filter 3	Color filter 4
VHR	98.3	98.1	98.6	98.5
ID	124	150	121	122
Image sticking	D	D	D	D

[0124] The liquid crystal display devices of Comparative Examples 1 to 8 showed lower VHR and larger ID than the liquid crystal display devices of the present invention. Also, in evaluation of image sticking, the occurrence of residual image at an unallowable level was observed.

(COMPARATIVE EXAMPLE 9)

[0125] The liquid crystal composition 1 shown in Table 2 and having negative dielectric anisotropy was interposed in the VA cell used in Example 1, and a liquid crystal display device of Comparative Example 9 was formed by using the comparative color filter 1 shown in Table 1, and VHR and ID of the resultant liquid crystal display device were measured. Also, image sticking of the resultant liquid crystal display device was evaluated. The results are shown in Table 7.

[0126]

[Table 7]

	Comparative Example 9
Liquid crystal composition	Liquid crystal composition 1
Color filter	Comparative color filter 1
VHR	97.7
ID	208
Image sticking	D

[0127] The liquid crystal display device of Comparative Example 9 showed lower VHR and larger ID than the liquid crystal display devices of the present invention. Also, in evaluation of image sticking, the occurrence of residual image at an unallowable level was observed.

(COMPARATIVE EXAMPLES 10 to 13)

[0128] As in Example 1, comparative liquid crystal composition 3 shown in Table 8 and having negative dielectric anisotropy was interposed, and liquid crystal display devices of Comparative Examples 10 to 13 were formed by using the color filters 1 to 4 shown in Table 1, and VHR and ID of the resultant liquid crystal display devices were measured. Also, image sticking of the resultant liquid crystal display devices was evaluated. The results are shown in Table 9.

[0129]

[Table 8]

	Comparative liquid crystal composition 3
3-Cy-Ph15-O4	11
5-Cy-Ph15-O4	11
2-Cy-Cy-Ph15-1	12
2-Cy-Cy-Ph15-O2	9

(continued)

	Comparative liquid crystal composition 3
3-Cy-Cb1-Ph15-O2	4
3-Cy-Cy-Ph15-1	12
3-Cy-Cy-Ph15-O2	9
5-Cy-Cb1-Ph15-O2	6
5-Cy-Cb-Ph15-O2	18
5-Cy-Cy-Ph15-O2	8
Composition ratio total (%)	100
Tni/°C	118.1
$\Delta n(20^\circ\text{C})$	0.105
ne(20°C)	1.586
$\Delta \varepsilon(20^\circ\text{C})$	-6.4
$\varepsilon \perp(20^\circ\text{C})$	10.4
K3/K1(20°C)	1.05
K1/pN(20°C)	20.2

[0130]

[Table 9]

	Comparative Example 10	Comparative Example 11	Comparative Example 12	Comparative Example 13
Liquid crystal composition	Comparative liquid crystal composition 3	Comparative liquid crystal composition 3	Comparative liquid crystal composition 3	Comparative liquid crystal composition 3
Color filter	Color filter 1	Color filter 2	Color filter 3	Color filter 4
VHR	98.5	98.2	98.6	98.6
ID	107	138	107	112
Image sticking	C	D	C	D

[0131] The liquid crystal display devices of Comparative Examples 10 to 13 showed lower VHR and larger ID than the liquid crystal display devices of the present invention. Also, in evaluation of image sticking, the occurrence of residual image at an unallowable level was observed.

(EXAMPLES 5 to 12)

[0132] As in Example 1, each of liquid crystals with negative dielectric anisotropy shown in Table 10 was held, and liquid crystal display devices of Examples 5 to 12 were formed by using the color filters shown in Table 1. VHR and ID of the resultant liquid crystal display devices were measured. Also, image sticking of the resultant liquid crystal display devices was evaluated. The results are shown in Tables 11 and 12.

[0133]

[Table 10]

	Liquid crystal composition 2	Liquid crystal composition 3
3-Cy-10-Ph5-O2	11	11
5-Cy-10-Ph5-O2	10	10

EP 2 657 754 A1

(continued)

	Liquid crystal composition 2	Liquid crystal composition 3
0d1-Cy-Cy-3	20	
0d1-Cy-Cy-5		20
0d3-Cy-Cy-3	10	10
3-Cy-1=1-Cy-3	10	10
0d1-Cy-1O-Ph5-O1-Cy-3		5
0d1-Cy-Cy-1O-Ph5-O3d0		5
0d1-Cy-Cy-1O-Ph5-O4d0		5
2-Cy-Cy-1O-Ph5-O2	5	5
3-Cy-Cy-1O-Ph5-O2	12	12
4-Cy-Cy-1O-Ph5-O2	5	5
0d1-Cy-1O-Ph5-O1-Cy-Cy-1d0	12	
0d1-Cy-1O-Ph5-O1-Cy-Cy-2	5	
0d1-Cy-1O-Ph5-O1-Cy-Cy-3		2
Composition ratio total (%)	100	100
Tni/°C	79.6	78.9
$\Delta n(20^\circ\text{C})$	0.074	0.075
η 20/mPa·s	17.8	18.2
$\Delta \varepsilon(20^\circ\text{C})$	-4.8	-4.8

[0134]

[Table 11]

	Example 5	Example 6	Example 7	Example 8
Liquid crystal composition	Liquid crystal composition 2	Liquid crystal composition 2	Liquid crystal composition 2	Liquid crystal composition 2
Color filter	Color filter 1	Color filter 2	Color filter 3	Color filter 4
VHR	99.2	99.0	99.7	99.3
ID	68	73	14	28
Image sticking	A	B	A	A

[0135]

[Table 12]

	Example 9	Example 10	Example 11	Example 12
Liquid crystal composition	Liquid crystal composition 3	Liquid crystal composition 3	Liquid crystal composition 3	Liquid crystal composition 3
Color filter	Color filter 1	Color filter 2	Color filter 3	Color filter 4
VHR	99.0	99.1	99.6	99.4
ID	79	78	19	25
Image sticking	B	B	A	A

EP 2 657 754 A1

[0136] The liquid crystal display devices of Examples 5 to 12 could realize high VHR and small ID. Also, in evaluation of image sticking, no residual image or slight residual image at an allowable level was observed.

(EXAMPLES 13 to 28)

[0137] As in Example 1, each of liquid crystals with negative dielectric anisotropy shown in Table 13 was held, and liquid crystal display devices of Examples 13 to 28 were formed by using the color filters shown in Table 1. VHR and ID of the resultant liquid crystal display devices were measured. Also, image sticking of the resultant liquid crystal display devices was evaluated. The results are shown in Tables 14 to 17.

[0138]

[Table 13]

	Liquid crystal composition 4	Liquid crystal composition 5	Liquid crystal composition 6	Liquid crystal composition 7
0d1-Cy-10-Ph5-O3d0				5
0d1-Cy-10-Ph5-O4d0				5
0d1-Cy-Cy-3	10			4
3-Cy-Cy-2	10	18		10
3-Cy-Cy-4		6	15	3
3-Cy-Ph-O2	12	12	15	4
5-Ph-Ph-1	10	3	3	10
0d1-Cy-10-Ph5-O1-Cy-2	10	10	10	
0d1-Cy-10-Ph5-O1-Cy-3	12	12	12	
0d1-Cy-10-Ph5-O1-Cy-4	12	12	12	
0d1-Cy-10-Ph5-O1-Cy-5	10	10	10	
0d1-Cy-Cy-10-Ph5-O1d0				10
0d1-Cy-Cy-10-Ph5-O2d0				10
0d1-Cy-Cy-10-Ph5-O3d0				15
0d1-Cy-Cy-10-Ph5-O4d0				15
3-Cy-Cy-Ph-1	6	3		6
0d1-Cy-10-Ph5-O1-Cy-Cy-2	4	4	4	
0d1-Cy-10-Ph5-O1-Cy-Cy-3	4	4	4	
Composition ratio total (%)	100	100	100	100
Tni/°C	75.5	81.8	83.5	75.1
Δn(20°C)	0.088	0.077	0.078	0.087

EP 2 657 754 A1

(continued)

	Liquid crystal composition 4	Liquid crystal composition 5	Liquid crystal composition 6	Liquid crystal composition 7
5 η 20/mPa·s	16	16.5	20.2	15.5
$\Delta \varepsilon$ (20°C)	-4.2	-4.2	-4.2	-4.3

[0139]

10

[Table 14]

	Example 13	Example 14	Example 15	Example 16
15 Liquid crystal composition	Liquid crystal composition 4	Liquid crystal composition 4	Liquid crystal composition 4	Liquid crystal composition 4
Color filter	Color filter 1	Color filter 2	Color filter 3	Color filter 4
VHR	99.0	99.2	99.4	99.5
ID	64	57	26	18
20 Image sticking	A	A	A	A

[0140]

25

[Table 15]

	Example 17	Example 18	Example 19	Example 20
30 Liquid crystal composition	Liquid crystal composition 5	Liquid crystal composition 5	Liquid crystal composition 5	Liquid crystal composition 5
Color filter	Color filter 1	Color filter 2	Color filter 3	Color filter 4
VHR	99.1	99.0	99.6	99.4
ID	59	71	16	21
35 Image sticking	A	B	A	A

[0141]

40

[Table 16]

	Example 21	Example 22	Example 23	Example 24
45 Liquid crystal composition	Liquid crystal composition 6	Liquid crystal composition 6	Liquid crystal composition 6	Liquid crystal composition 6
Color filter	Color filter 1	Color filter 2	Color filter 3	Color filter 4
VHR	99.2	99.1	99.6	99.3
ID	64	80	17	26
50 Image sticking	A	B	A	A

[0142]

55

[Table 17]

	Example 25	Example 26	Example 27	Example 28
55 Liquid crystal composition	Liquid crystal composition 7	Liquid crystal composition 7	Liquid crystal composition 7	Liquid crystal composition 7

EP 2 657 754 A1

(continued)

	Example 25	Example 26	Example 27	Example 28
Color filter	Color filter 1	Color filter 2	Color filter 3	Color filter 4
VHR	99.3	99.0	99.5	99.2
ID	53	88	23	42
Image sticking	A	B	A	A

[0143] The liquid crystal display devices of Examples 13 to 28 could realize high VHR and small ID. Also, in evaluation of image sticking, no residual image or slight residual image at an allowable level was observed.

(EXAMPLES 29 to 40)

[0144] As in Example 1, each of liquid crystals with negative dielectric anisotropy shown in Table 18 was held, and liquid crystal display devices of Examples 29 to 40 were formed by using the color filters shown in Table 1. VHR and ID of the resultant liquid crystal display devices were measured. Also, image sticking of the resultant liquid crystal display devices was evaluated. The results are shown in Tables 19 to 21.

[0145]

[Table 18]

	Liquid crystal composition 8	Liquid crystal composition 9	Liquid crystal composition 10
2-Cy-2-Nd4-O2		4	4
2-Cy-2-Nd4-O4		4	4
3-Cy-10-Ch3-5	3		
3-Cy-10-Nd4-O4	3	4	4
5-Cy-10-Ch3-5	3		
5-Cy-10-Nd4-O2	2		
5-Cy-10-Nd4-O3	3	4	4
0d1-Cy-Cy-5		23	
0d3-Cy-Cy-3		10	
1d1-Cy-Cy-3		8	
3-Cy-Cy-2	15		
3-Cy-Cy-4	7	6	22
3-Cy-Cy-5	7		22
3-Cy-Ph-2		15	15
3-Cy-Ph-O1	5		
3-Cy-Ph-O2	5		
5-Ph-Ph-1	6		
2-Cy-Cy-10-Nd4-O2	3	4	4
2-Cy-Cy-10-Nd4-O4	2	4	4
3-Cy-2-Cy-10-Nd4-O2	4		
3-Cy-2-Cy-10-Nd4-O3	4		
3-Cy-Cy-10-Ch3-5	3		
3-Cy-Cy-10-Nd4-O4	3	4	4

EP 2 657 754 A1

(continued)

	Liquid crystal composition 8	Liquid crystal composition 9	Liquid crystal composition 10
5	4-Cy-Cy-1O-Ch3-5	3	
	4-Cy-Cy-1O-Nd4-O2	2	4
	4-Cy-Cy-2-Nd4-O2		6
10	3-Cy-Cy-Ph-1	8	3
	Composition ratio total (%)	100	100
	Tni/°C	92	91
	$\Delta n(20^\circ\text{C})$	0.093	0.092
15	η 20/mPa·s	24.9	25.5
	$\Delta \varepsilon(20^\circ\text{C})$	-3.3	-3.2

[0146]

20

[Table 19]

	Example 29	Example 30	Example 31	Example 32
25	Liquid crystal composition	Liquid crystal composition 8	Liquid crystal composition 8	Liquid crystal composition 8
	Color filter	Color filter 1	Color filter 2	Color filter 3
	VHR	98.9	99.2	99.7
	ID	108	95	13
30	Image sticking	B	B	A

[0147]

35

[Table 20]

	Example 33	Example 34	Example 35	Example 36
40	Liquid crystal composition	Liquid crystal composition 9	Liquid crystal composition 9	Liquid crystal composition 9
	Color filter	Color filter 1	Color filter 2	Color filter 3
	VHR	99.2	99.2	99.6
	ID	98	96	19
45	Image sticking	B	B	A

[0148]

50

[Table 21]

	Example 37	Example 38	Example 39	Example 40
55	Liquid crystal composition	Liquid crystal composition 10	Liquid crystal composition 10	Liquid crystal composition 10
	Color filter	Color filter 1	Color filter 2	Color filter 3
	VHR	99.1	99.1	99.5
	ID	103	107	21

EP 2 657 754 A1

(continued)

	Example 37	Example 38	Example 39	Example 40
Image sticking	B	B	A	A

[0149] The liquid crystal display devices of Examples 29 to 40 could realize high VHR and small ID. Also, in evaluation of image sticking, no residual image or slight residual image at an allowable level was observed.

(EXAMPLES 41 to 48)

[0150] As in Example 1, each of liquid crystals with negative dielectric anisotropy shown in Table 22 was held, and liquid crystal display devices of Examples 41 to 48 were formed by using the color filters shown in Table 1. VHR and ID of the resultant liquid crystal display devices were measured. Also, image sticking of the resultant liquid crystal display devices was evaluated. The results are shown in Tables 23 and 24.

[0151]

[Table 22]

	Liquid crystal composition 11	Liquid crystal composition 12
3-Cy-1O-Ch3-5	2	
3-Cy-2-Ph5-O2	6	10
3-Cy-Ph5-O2		10
4-Cy-1O-Nd4-O2	5	5
5-Cy-1O-Ch3-5	2	
0d1-Cy-Cy-5		16
3-Cy-1=1-Cy-3		10
3-Cy-Cy-2	15	
3-Cy-Cy-4	7	
3-Cy-Cy-5	7	
3-Cy-Ph-O1	6	
3-Cy-2-Cy-1O-Nd4-O2	3	
3-Cy-2-Cy-1O-Nd4-O3	3	
3-Cy-Cy-1O-Ch3-5	2	
3-Cy-Cy-2-Ph5-O2	7	10
3-Cy-Cy-Ph5-1	7	10
3-Cy-Cy-Ph5-O2	7	10
4-Cy-Cy-10-Ch3-5	2	
5-Cy-Cy-1O-Nd4-O3	5	5
0d1-Cy-Cy-Ph-1		14
3-Cy-Cy-Ph-1	14	
Composition ratio total (%)	100	100
Tni/°C	87	85
Δn(20°C)	0.086	0.085
η 20/mPa·s	24.2	23.8
Δε(20°C)	-2.7	-2.5

[0152]

[Table 23]

	Example 41	Example 42	Example 43	Example 44
Liquid crystal composition	Liquid crystal composition 11	Liquid crystal composition 11	Liquid crystal composition 11	Liquid crystal composition 11
Color filter	Color filter 1	Color filter 2	Color filter 3	Color filter 4
VHR	99.4	99.2	99.7	99.6
ID	82	94	12	16
Image sticking	A	B	A	A

[0153]

[Table 24]

	Example 45	Example 46	Example 47	Example 48
Liquid crystal composition	Liquid crystal composition 12	Liquid crystal composition 12	Liquid crystal composition 12	Liquid crystal composition 12
Color filter	Color filter 1	Color filter 2	Color filter 3	Color filter 4
VHR	99.3	99.4	99.8	99.6
ID	102	76	10	19
Image sticking	B	A	A	A

[0154] The liquid crystal display devices of Examples 41 to 48 could realize high VHR and small ID. Also, in evaluation of image sticking, no residual image or slight residual image at an allowable level was observed.

(EXAMPLES 49 to 60)

[0155] As in Example 1, each of liquid crystals with negative dielectric anisotropy shown in Table 25 was held, and liquid crystal display devices of Examples 49 to 60 were formed by using the color filters shown in Table 1. VHR and ID of the resultant liquid crystal display devices were measured. Also, image sticking of the resultant liquid crystal display devices was evaluated. The results are shown in Tables 26 to 28.

[0156]

[Table 25]

	Liquid crystal composition 13	Liquid crystal composition 14	Liquid crystal composition 15
3-Cy-10-Ch3-5	3		
3-Cy-10-Nd4-O4	3		4
5-Cy-10-Ch3-5	3		
5-Cy-10-Nd4-O2	2	4	4
5-Cy-10-Nd4-O3	3	4	4
3-Cy-Cy-2	7	21	11
3-Cy-Cy-4	11	7	7
3-Cy-Cy-5	11	7	7
3-Cy-Ph-2			7
3-Cy-Ph-O1	7	13	7

EP 2 657 754 A1

(continued)

	Liquid crystal composition 13	Liquid crystal composition 14	Liquid crystal composition 15
5	3-Cy-Ph-O2	7	13
	5-Ph-Ph-1	6	13
	2-Cy-Cy-1O-Nd4-O2	3	4
10	2-Cy-Cy-1O-Nd4-O4	2	
	3-Cy-2-Cy-1O-Nd4-O2	3	4
	3-Cy-2-Cy-1O-Nd4-O3	3	4
	3-Cy-Cy-1O-Ch3-5	2	
15	3-Cy-Cy-1O-Nd4-O4	3	4
	4-Cy-Cy-1O-Ch3-5	2	
	4-Cy-Cy-1O-Nd4-O2	2	
20	3-Cy-Cy-Ph-1	8	9
	3-Cy-Ph-Ph-1	9	6
	Composition ratio total (%)	100	100
	T _{ni} /°C	86	81
25	Δn(20°C)	0.091	0.082
	η 20/mPa·s	20	19.2
	Δε (20°C)	-2.7	-2.5

30 [0157]

[Table 26]

	Example 49	Example 50	Example 51	Example 52
35	Liquid crystal composition	Liquid crystal composition 13	Liquid crystal composition 13	Liquid crystal composition 13
	Color filter	Color filter 1	Color filter 3	Color filter 4
	VHR	99.2	99.1	99.6
40	ID	99.4	99.6	99.4
	Image sticking	94	98	21
		A	B	A

45 [0158]

[Table 27]

	Example 53	Example 54	Example 55	Example 56
50	Liquid crystal composition	Liquid crystal composition 14	Liquid crystal composition 14	Liquid crystal composition 14
	Color filter	Color filter 1	Color filter 2	Color filter 3
	VHR	99.1	98.9	99.6
55	ID	102	107	24
	Image sticking	38	38	24
		B	B	A

[0159]

[Table 28]

	Example 57	Example 58	Example 59	Example 60
Liquid crystal composition	Liquid crystal composition 15	Liquid crystal composition 15	Liquid crystal composition 15	Liquid crystal composition 15
Color filter	Color filter 1	Color filter 2	Color filter 3	Color filter 4
VHR	99.2	99.0	99.5	99.4
ID	89	99	32	34
Image sticking	A	B	A	A

[0160] The liquid crystal display devices of Examples 49 to 60 could realize high VHR and small ID. Also, in evaluation of image sticking, no residual image or slight residual image at an allowable level was observed.

(EXAMPLES 61 to 76)

[0161] As in Example 1, each of liquid crystals with negative dielectric anisotropy shown in Table 29 was held, and liquid crystal display devices of Examples 61 to 76 were formed by using the color filters shown in Table 1. VHR and ID of the resultant liquid crystal display devices were measured. Also, image sticking of the resultant liquid crystal display devices was evaluated. The results are shown in Tables 30 to 33.

[0162]

[Table 29]

	Liquid crystal composition 16	Liquid crystal composition 17	Liquid crystal composition 18	Liquid crystal composition 19
3-Cy-1O-Ph5-O2		2		11
5-Cy-1O-Ph5-O2		2		10
0d1-Cy-Cy-3			30	
0d1-Cy-Cy-5	4	4	10	20
0d3-Cy-Cy-3				10
3-Cy-1=1-Cy-3				10
3-Cy-Cy-2	4	4		
3-Cy-Cy-4	4	4		
3-Cy-Cy-5	4	4		
3-Cy-Ph-O1	2	2		
5-Ph-Ph-1	20	20		
0d1-Cy-1O-Ph5-O1-Cy-1d0				12
0d1-Cy-1O-Ph5-O1-Cy-2	7	8	10	
0d1-Cy-1O-Ph5-O1-Cy-3	7	8	12	
0d1-Cy-1O-Ph5-O1-Cy-4	7	8	12	
0d1-Cy-1O-Ph5-O1-Cy-5	5		10	

EP 2 657 754 A1

(continued)

	Liquid crystal composition 16	Liquid crystal composition 17	Liquid crystal composition 18	Liquid crystal composition 19
5	0d1-Cy-Cy-10-Ph5-O3d0		6	
	0d1 -Cy-Cy-10-Ph5-O4d0		6	
10	2-Cy-Cy-10-Ph5-O2	13		5
	3-Cy-Cy-10-Ph5-O2	13		12
15	4-Cy-Cy-10-Ph5-O2	13		5
	0d1-Cy-10-Ph5-O1-Cy-Cy-2		2	5
20	0d1-Cy-10-Ph5-O1-Cy-Cy-3	5	2	
	Composition ratio total (%)	110	100	100
25	Tni/°C	79.8	83.6	83.1
	$\Delta n(20^\circ\text{C})$	0.101	0.075	0.075
	η 20/mPa·s	27.6	15.1	18
30	$\Delta \varepsilon(20^\circ\text{C})$	-4.1	-4.8	-4.8

[0163]

[Table 30]

	Example 61	Example 62	Example 63	Example 64
35	Liquid crystal composition	Liquid crystal composition 16	Liquid crystal composition 16	Liquid crystal composition 16
	Color filter	Color filter 1	Color filter 3	Color filter 4
40	VHR	99.1	99.4	99.2
	ID	86	31	57
	Image sticking	A	A	A

[0164]

[Table 31]

	Example 65	Example 66	Example 67	Example 68
50	Liquid crystal composition	Liquid crystal composition 17	Liquid crystal composition 17	Liquid crystal composition 17
	Color filter	Color filter 1	Color filter 3	Color filter 4
55	VHR	99.2	99.4	99.3
	ID	87	34	41
	Image sticking	A	A	A

[0165]

[Table 32]

	Example 69	Example 70	Example 71	Example 72
Liquid crystal composition	Liquid crystal composition 18	Liquid crystal composition 18	Liquid crystal composition 18	Liquid crystal composition 18
Color filter	Color filter 1	Color filter 2	Color filter 3	Color filter 4
VHR	99.1	99.2	99.5	99.3
ID	94	89	28	37
Image sticking	B	A	A	A

[0166]

[Table 33]

	Example 73	Example 74	Example 75	Example 76
Liquid crystal composition	Liquid crystal composition 19	Liquid crystal composition 19	Liquid crystal composition 19	Liquid crystal composition 19
Color filter	Color filter 1	Color filter 2	Color filter 3	Color filter 4
VHR	99.0	99.0	99.6	99.4
ID	102	97	19	34
Image sticking	B	B	A	A

[0167] The liquid crystal display devices of Examples 61 to 76 could realize high VHR and small ID. Also, in evaluation of image sticking, no residual image or slight residual image at an allowable level was observed.

(EXAMPLES 77 to 92)

[0168] As in Example 1, each of liquid crystals with negative dielectric anisotropy shown in Table 34 was held, and liquid crystal display devices of Examples 77 to 92 were formed by using the color filters shown in Table 1. VHR and ID of the resultant liquid crystal display devices were measured. Also, image sticking of the resultant liquid crystal display devices was evaluated. The results are shown in Tables 35 to 38.

[0169]

[Table 34]

	Liquid crystal composition 20	Liquid crystal composition 21	Liquid crystal composition 22	Liquid crystal composition 23
2-Cy-2-Nd4-O2		10		10
3-Cy-10-Ch3-O5	7		10	
3-Cy-2-Nd4-O4		10		10
4-Cy-2-Nd4-O2		10		10
5-Cy-10-Ch3-O5	7		10	
5-Cy-2-Nd4-O2		5		5
0d1-Cy-Cy-3	30	40		
0d1-Cy-Cy-5			15	20
3-Cy-Cy-4			15	14
3-Cy-Ph-O2				10

EP 2 657 754 A1

(continued)

	Liquid crystal composition 20	Liquid crystal composition 21	Liquid crystal composition 22	Liquid crystal composition 23
5	5-Ph-Ph-1	10	10	
	2-Cy-Cy-2-Nd4-O2	4		4
	3-Cy-Cy-1O-Ph5-O1		3	
10	3-Cy-Cy-1O-Ph5-O2		5	
	3-Cy-Cy-2-Ph5-O2		10	
15	3-Cy-Cy-Ph5-O2		10	
	4-Cy-Cy-1O-Ph5-O1		3	
	4-Cy-Cy-2-Nd4-O2	4		4
20	0d1-Cy-Cy-Ph-1	6	9	4
	0d1-Cy-Ph-Ph-3	5		3
	0d3-Cy-Cy-Ph-1	6		6
	組成比計 (%)	100	100	100
25	Composition ratio total (%)	82.7	80.9	81.8
	$\Delta n(20^\circ\text{C})$	0.087	0.084	0.097
30	η 20/mPa·s	19.4	26	22.7
	$\Delta \varepsilon(20^\circ\text{C})$	-3.1	-3.1	-3.2

[0170]

[Table 35]

	Example 77	Example 78	Example 79	Example 80
	Liquid crystal composition 20	Liquid crystal composition 20	Liquid crystal composition 20	Liquid crystal composition 20
40	Color filter 1	Color filter 2	Color filter 3	Color filter 4
	VHR 99.2	99.1	99.7	99.5
	ID 71	76	14	22
45	Image sticking A	B	A	A

[0171]

[Table 36]

	Example 81	Example 82	Example 83	Example 84
	Liquid crystal composition 21	Liquid crystal composition 21	Liquid crystal composition 21	Liquid crystal composition 21
50	Color filter 1	Color filter 2	Color filter 3	Color filter 4
	VHR 99.1	98.9	99.4	99.3
55	ID 97	104	36	75

EP 2 657 754 A1

(continued)

	Example 81	Example 82	Example 83	Example 84
Image sticking	B	B	A	A

[0172]

[Table 37]

	Example 85	Example 86	Example 87	Example 88
Liquid crystal composition	Liquid crystal composition 22	Liquid crystal composition 22	Liquid crystal composition 22	Liquid crystal composition 22
Color filter	Color filter 1	Color filter 2	Color filter 3	Color filter 4
VHR	99.3	99.2	99.6	99.4
ID	68	74	27	34
Image sticking	A	B	A	A

[0173]

[Table 38]

	Example 89	Example 90	Example 91	Example 92
Liquid crystal composition	Liquid crystal composition 23	Liquid crystal composition 23	Liquid crystal composition 23	Liquid crystal composition 23
Color filter	Color filter 1	Color filter 2	Color filter 3	Color filter 4
VHR	99.1	99.0	99.5	99.1
ID	100	106	35	86
Image sticking	B	B	A	A

[0174] The liquid crystal display devices of Examples 77 to 92 could realize high VHR and small ID. Also, in evaluation of image sticking, no residual image or slight residual image at an allowable level was observed.

(EXAMPLES 93 to 100)

[0175] As in Example 1, each of liquid crystals with negative dielectric anisotropy shown in Table 39 was held, and liquid crystal display devices of Examples 93 to 100 were formed by using the color filters shown in Table 1. VHR and ID of the resultant liquid crystal display devices were measured. Also, image sticking of the resultant liquid crystal display devices was evaluated. The results are shown in Tables 40 and 41.

[0176]

[Table 39]

	Liquid crystal composition 24	Liquid crystal composition 25
3-Cy-Ph5-O4	9	10
3O-Ph5-Ph5-O2	8	
5-Cy-Ph5-O4	9	10
0d1-Cy-Cy-5	5	
0d1-O-Cy-Cy-Ph5-1		10
0d2-Cy-Cy-Ph5-O2	10	
0d2-O-Cy-Cy-Ph5-1		10

EP 2 657 754 A1

(continued)

	Liquid crystal composition 24	Liquid crystal composition 25
1d2-O-Cy-Cy-Ph5-1		8
2-Cy-Cy-Ph5-1	11	12
2-Cy-Cy-Ph5-O2	9	10
3-Cy-Cy-Ph5-1	10	11
3-Cy-Cy-Ph5-O2	10	10
3-O-Cy-Cy-Ph5-O2	10	
5-Cy-Cy-Ph5-O2	9	9
Composition ratio total (%)	100	100
Tni/°C	101.2	103.9
$\Delta n(20^\circ\text{C})$	0.100	0.098
$n_e(20^\circ\text{C})$	1.581	1.579
$\Delta \varepsilon(20^\circ\text{C})$	-7.5	-5.5
$\varepsilon \perp(20^\circ\text{C})$	11.9	9.5
K3/K1(20°C)	1.08	1.16
K1/pN(20°C)	15.8	16.5

[0177]

[Table 40]

	Example 93	Example 94	Example 95	Example 96
Liquid crystal composition	Liquid crystal composition 24	Liquid crystal composition 24	Liquid crystal composition 24	Liquid crystal composition 24
Color filter	Color filter 1	Color filter 2	Color filter 3	Color filter 4
VHR	99.3	99.3	99.8	99.4
ID	59	61	11	52
Image sticking	A	A	A	A

[0178]

[Table 41]

	Example 97	Example 98	Example 99	Example 100
Liquid crystal composition	Liquid crystal composition 25	Liquid crystal composition 25	Liquid crystal composition 25	Liquid crystal composition 25
Color filter	Color filter 1	Color filter 2	Color filter 3	Color filter 4
VHR	99.2	99.3	99.7	99.3
ID	68	64	18	47
Image sticking	A	A	A	A

[0179] The liquid crystal display devices of Examples 93 to 100 could realize high VHR and small ID. Also, in evaluation of image sticking, no residual image or slight residual image at an allowable level was observed.

(EXAMPLES 101 to 112)

[0180] As in Example 1, each of liquid crystals with negative dielectric anisotropy shown in Table 42 was held, and liquid crystal display devices of Examples 101 to 112 were formed by using the color filters shown in Table 1. VHR and ID of the resultant liquid crystal display devices were measured. Also, image sticking of the resultant liquid crystal display devices was evaluated. The results are shown in Tables 43 to 45.

[0181]

[Table 42]

	Liquid crystal composition 26	Liquid crystal composition 27	Liquid crystal composition 28
3-Cy-Ph5-O4	16	16	16
5-Cy-Ph5-O2	12	16	16
0d1-Cy-Cy-5	7	4	10
0d3-Ph-Ph-1	11	10	10
1d1-Cy-Cy-3	9	8	
2-Cy-Ph-Ph5-O2	13	12	12
3-Cy-Cy-Ph5-O2	6	7	10
3-Cy-Ph-Ph5-O2	12	12	12
0d1-Cy-Cy-Ph-1	4	4	4
3-Cy-Ph-Ph-2	10	11	10
Composition ratio total (%)	100	100	100
Tni/°C	80.2	80.3	80.9
$\Delta n(20^\circ\text{C})$	0.128	0.129	0.126
ne(20°C)	1.492	1.491	1.491
$\Delta \varepsilon(20^\circ\text{C})$	-3.3	-3.5	-3.7
$\varepsilon \perp(20^\circ\text{C})$	6.8	7.1	7.4
K3/K1(20°C)	0.99	1.01	1.04
K1/pN(20°C)	16.7	15.2	16.4

[0182]

[Table 43]

	Example 101	Example 102	Example 103	Example 104
Liquid crystal composition	Liquid crystal composition 26	Liquid crystal composition 26	Liquid crystal composition 26	Liquid crystal composition 26
Color filter	Color filter 1	Color filter 2	Color filter 3	Color filter 4
VHR	99.3	99.1	99.6	99.3
ID	57	78	28	49
Image sticking	A	A	A	A

[0183]

EP 2 657 754 A1

[Table 44]

	Example 105	Example 106	Example 107	Example 108
Liquid crystal composition	Liquid crystal composition 27	Liquid crystal composition 27	Liquid crystal composition 27	Liquid crystal composition 27
Color filter	Color filter 1	Color filter 2	Color filter 3	Color filter
VHR	99.2	99.1	99.6	99.4
ID	69	82	26	41
Image sticking	A	B	A	A

[0184]

[Table 45]

	Example 109	Example 110	Example 111	Example 112
Liquid crystal composition	Liquid crystal composition 28	Liquid crystal composition 28	Liquid crystal composition 28	Liquid crystal composition 28
Color filter	Color filter 1	Color filter 2	Color filter 3	Color filter 4
VHR	99.3	99.2	99.5	99.3
ID	54	80	30	53
Image sticking	A	A	A	A

[0185] The liquid crystal display devices of Examples 101 to 112 could realize high VHR and small ID. Also, in evaluation of image sticking, no residual image or slight residual image at an allowable level was observed.

(EXAMPLES 113 to 124)

[0186] As in Example 1, each of liquid crystals with negative dielectric anisotropy shown in Table 46 was held, and liquid crystal display devices of Examples 101 to 112 were formed by using the color filters shown in Table 1. VHR and ID of the resultant liquid crystal display devices were measured. Also, image sticking of the resultant liquid crystal display devices was evaluated. The results are shown in Tables 47 to 49.

[0187]

[Table 46]

	Liquid crystal composition 29	Liquid crystal composition 30	Liquid crystal composition 31
3-Cy-Ph5-O4	16	16	16
5-Cy-Ph5-O2	12	16	16
0d1-Cy-Cy-5	12	10	20
0d3-Ph-Ph-1	6	4	
1d1-Cy-Cy-3	9	8	
2-Ph-Ph5-Ph-2	13	12	12
3-Cy-Cy-Ph5-O2	6	7	10
3-Cy-Ph-Ph5-O2	12	12	12
0d1-Cy-Cy-Ph-1	4	4	4
3-Cy-Ph-Ph-2	10	11	10
Composition ratio total (%)	100	100	100

EP 2 657 754 A1

(continued)

	Liquid crystal composition 29	Liquid crystal composition 30	Liquid crystal composition 31
T_{ni}/°C	81.7	81.2	80.9
Δn(20°C)	0.127	0.130	0.131
n_e(20°C)	1.494	1.495	1.498
Δε(20°C)	-3.0	-3.3	-3.6
ε_⊥(20°C)	6.9	7.2	7.5
K3/K1(20°C)	1.02	1.03	1.06
K1/pN(20°C)	15.8	15.6	16.2

[0188]

[Table 47]

	Example 113	Example 114	Example 115	Example 116
Liquid crystal composition	Liquid crystal composition 29	Liquid crystal composition 29	Liquid crystal composition 29	Liquid crystal composition 29
Color filter	Color filter 1	Color filter 2	Color filter 3	Color filter 4
VHR	99.3	99.2	99.7	99.5
ID	55	81	18	44
Image sticking	A	B	A	A

[0189]

[Table 48]

	Example 117	Example 118	Example 119	Example 120
Liquid crystal composition	Liquid crystal composition 30	Liquid crystal composition 30	Liquid crystal composition 30	Liquid crystal composition 30
Color filter	Color filter 1	Color filter 2	Color filter 3	Color filter 4
VHR	99.4	99.0	99.5	99.6
ID	42	84	32	27
Image sticking	A	B	A	A

[0190]

[Table 49]

	121	122	123	124
Liquid crystal composition	Liquid crystal composition 31	Liquid crystal composition 31	Liquid crystal composition 31	Liquid crystal composition 31
Color filter	Color filter 1	Color filter 2	Color filter 3	Color filter 4
VHR	99.3	99.1	99.7	99.2
ID	54	86	22	61
Image sticking	A	B	A	A

EP 2 657 754 A1

[0191] The liquid crystal display devices of Examples 113 to 124 could realize high VHR and small ID. Also, in evaluation of image sticking, no residual image or slight residual image at an allowable level was observed.

(EXAMPLES 125 to 128)

[0192] As in Example 1, a liquid crystal with negative dielectric anisotropy shown in Table 50 was held, and liquid crystal display devices of Examples 125 to 128 were formed by using the color filters shown in Table 1. VHR and ID of the resultant liquid crystal display devices were measured. Also, image sticking of the resultant liquid crystal display devices was evaluated. The results are shown in Table 51.

[0193]

[Table 50]

	Liquid crystal composition 32
Od1-Cy-Cy-5	20
3-Cy-2-Ph5-O2	20
Od1-Cy-Cy-Ph-1	5
5-Cy-2-Ph5-O2	20
3-Cy-Cy-2-Ph5-O2	3
5-Cr-Cy-Ph5-O2	3
3-Cy-Ph-PH5-O2	5
3-Ph-Ph-Ph-2	7
4-Ph-Phr-Phr2	7
3-Cy-Cy-VO-Ph-Cy-3	4
3-Cy-Cy-VO-Ph-Cy-4	3
3-Cy-Cy-VO-Ph-Cy-5	3
Composition ratio total (%)	100
Tni/°C	81.6
$\Delta n(20^\circ\text{C})$	0.127
ne(20°C)	1.495
$\Delta \varepsilon(20^\circ\text{C})$	-3.0

[0194]

[Table 51]

	Example 125	Example 126	Example 127	Example 128
Liquid crystal composition	Liquid crystal composition 32	Liquid crystal composition 32	Liquid crystal composition 32	Liquid crystal composition 32
Color filter	Color filter 1	Color filter 2	Color filter 3	Color filter 4
VHR	99.4	99.1	99.5	99.3
ID	59	78	23	45
Image sticking	A	B	A	A

[0195] The liquid crystal display devices of Examples 125 to 128 could realize high VHR and small ID. Also, in evaluation of image sticking, no residual image or slight residual image at an allowable level was observed.

(EXAMPLES 129 to 132)

[0196] A liquid crystal composition 33 was prepared by mixing 0.3% by mass of 2-methyl-acrylic acid 4'-{2-[4-(2-acryloyloxy-ethyl)-phenoxy-carbonyl]-ethyl}-biphenyl-4-yl ester with the liquid crystal composition 1 having negative dielectric anisotropy and used in Example 1. The liquid crystal composition 33 was interposed in a VA cell used in Example 1 and then polymerized by ultraviolet irradiation (3.0 J/cm²) for 600 seconds while a driving voltage was applied between electrodes. Next, liquid crystal display devices of Examples 129 to 132 were formed by using the color filters 1 to 4 shown in Table 1, and VHR and ID of the resultant liquid crystal display devices were measured. Also, image sticking of the resultant liquid crystal display devices was evaluated. The results are shown in Table 50.

[0197]

[Table 52]

	Example 129	Example 130	Example 131	Example 132
Liquid crystal composition	Liquid crystal composition 33	Liquid crystal composition 33	Liquid crystal composition 33	Liquid crystal composition 33
Color filter	Color filter 1	Color filter 2	Color filter 3	Color filter 4
VHR	99.0	98.8	99.3	99.2
ID	78	93	24	43
image sticking	A	B	A	A

[0198] The liquid crystal display devices of Examples 125 to 128 could realize high VHR and small ID. Also, in evaluation of image sticking, no residual image or slight residual image at an allowable level was observed.

The same measurement was performed using biphenyl-4, 4'-diyl bismethacrylate in place of 2-methyl-acrylic acid 4'-{2-[4-(2-acryloyloxy-ethyl)-phenoxy-carbonyl]-ethyl}-biphenyl-4-yl ester. As a result, like in Examples 129 to 132, high VHR and small ID could be realized, and in evaluation of image sticking, no residual image or slight residual image at an allowable level was observed.

(EXAMPLES 132 to 135)

[0199] A liquid crystal composition 34 was prepared by mixing 0.3% by mass of biphenyl-4, 4'-diyl bismethacrylate with the liquid crystal composition 29 having negative dielectric anisotropy. The liquid crystal composition 30 was interposed in a VA cell used in Example 1 and then polymerized by ultraviolet irradiation (3.0 J/cm²) for 600 seconds while a driving voltage was applied between electrodes. Next, liquid crystal display devices of Examples 132 to 135 were formed by using the color filters 1 to 4 shown in Table 1, and VHR and ID of the resultant liquid crystal display devices were measured. Also, image sticking of the resultant liquid crystal display devices was evaluated. The results are shown in Table 53.

[0200]

[Table 53]

	Example 132	Example 133	Example 134	Example 135
Liquid crystal composition	Liquid crystal composition 34	Liquid crystal composition 34	Liquid crystal composition 34	Liquid crystal composition 34
Color filter	Color filter 1	Color filter 2	Color filter 3	Color filter 4
VHR	99.3	99.1	99.5	99.4
ID	76	90	22	40
Image sticking	A	B	A	A

[0201] The liquid crystal display devices of Examples 132 to 135 could realize high VHR and small ID. Also, in evaluation of image sticking, no residual image or slight residual image at an allowable level was observed.

(EXAMPLES 136 to 139)

[0202] A liquid crystal composition 35 was prepared by mixing 0.3% by mass of 3-fluorobiphenyl-4, 4'-diyl bismethacrylate with the liquid crystal composition 32 having negative dielectric anisotropy. The liquid crystal composition 35 was interposed in a VA cell used in Example 1 and then polymerized by ultraviolet irradiation (3.0 J/cm²) for 600 seconds while a driving voltage was applied between electrodes. Next, liquid crystal display devices of Examples 136 to 139 were formed by using the color filters 1 to 4 shown in Table 1, and VHR and ID of the resultant liquid crystal display devices were measured. Also, image sticking of the resultant liquid crystal display devices was evaluated. The results are shown in Table 54.

[0203]

[Table 54]

	Example 136	Example 137	Example 138	Example 139
Liquid crystal composition	Liquid crystal composition 35	Liquid crystal composition 35	Liquid crystal composition 35	Liquid crystal composition 35
Color filter	Color filter 1	Color filter 2	Color filter 3	Color filter 4
VHR	99.2	98.9	99.5	99.6
ID	77	92	23	44
Image sticking	A	B	A	A

[0204] The liquid crystal display devices of Examples 136 to 139 could realize high VHR and small ID. Also, in evaluation of image sticking, no residual image or slight residual image at an allowable level was observed. Brief Description of Drawings

[0205] [Fig. 1] Fig. 1 is a drawing showing an example of a general liquid crystal display device.

[Fig. 2] Fig. 2 is a drawing showing an example of a liquid crystal display device according to the present invention.

Reference Signs List

[0206]

- 1 substrate
- 2 color filter layer
- 2a color filter layer containing specified dye and/or pigment
- 3a transparent electrode layer (common electrode)
- 3b pixel electrode layer
- 4 alignment film
- 5 liquid crystal layer
- 5a liquid crystal layer containing specified liquid crystal composition

Claims

1. A liquid crystal display device comprising a first substrate, a second substrate, a liquid crystal composition layer held between the first substrate and the second substrate, a color filter including a black matrix and at least RGB three-color pixel portions, a pixel electrode, and a common electrode, wherein the liquid crystal composition layer includes a liquid crystal composition which contains at least one compound selected from a compound group represented by general formula (LC1) to general formula (LC4),

[Chem. 1]

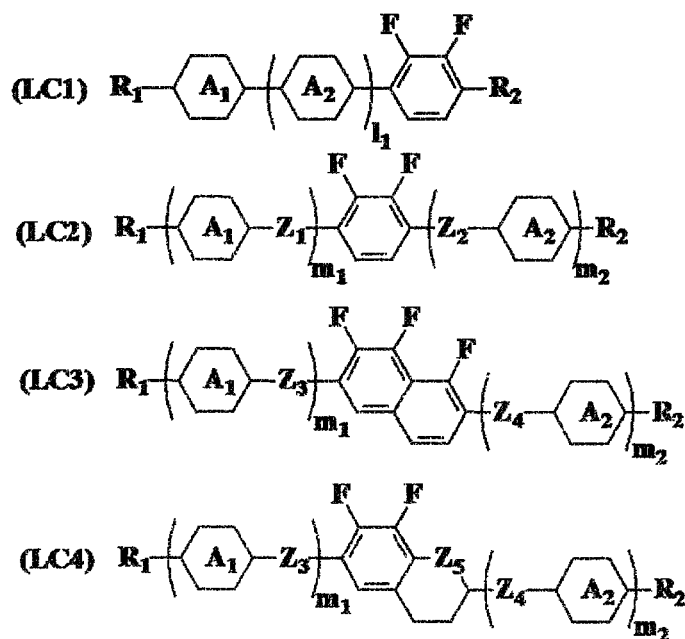

(in the formulae, R₁ and R₂ each independently represent an alkyl group having 1 to 15 carbon atoms, at least one CH₂ group in the alkyl group may be substituted by -O-, -CH=CH-, -CO-, -OCO-, -COO-, -C≡C-, -CF₂O-, or -OCF₂- so that oxygen atoms are not directly adjacent to each other, at least one hydrogen atom in the alkyl group may be arbitrarily substituted by a halogen, A₁ and A₂ each independently represent any one of the following structures,

[Chem. 2]

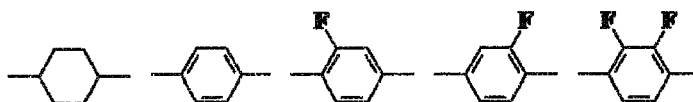

(at least one CH₂ group in a cyclohexane ring in the structures may be substituted by an oxygen atom, at least one CH group in a benzene ring in the structures may be substituted by a nitrogen atom, and at least one hydrogen atom in the structures may be substituted by Cl, CF₃, or OCF₃), Z₁ to Z₄ each independently represent a single bond, -CH=CH-, -C≡C-, -CH₂CH₂-, -(CH₂)₄-, -COO-, -OCH₂-, -CH₂O-, -OCF₂-, or -CF₂O-, Z₅ represents a CH₂ group or an oxygen atom, at least one of Z₁ and Z₂ present is not a single bond, I₁ represents 0 or 1, m₁ and m₂ each independently represent 0 to 3, and m₁ + m₂ is 1, 2, or 3), and the RGB three-color pixel portions include, as colorants, a diketopyrrolopyrrole pigment and/or anionic red organic dye in a R pixel portion, at least one selected from the group consisting of a halogenated copper phthalocyanine pigment, a phthalocyanine green dye, and a mixture of a phthalocyanine blue dye and an azo yellow organic dye in a G pixel portion, and a ε-type copper phthalocyanine pigment and/or cationic blue organic dye in a B pixel portion.

2. The liquid crystal display device according to Claim 1, wherein the RGB three-color pixel portions include, as colorants, C. I. Solvent Red 124 in the R pixel portion, a mixture of C. I. Solvent Blue 67 and C. I. Solvent Yellow 162 in the G pixel portion, and C. I. Solvent Blue 7 in the B pixel portion.
3. The liquid crystal display device according to Claim 1, wherein the RGB three-color pixel portions include, as colorants, C. I. Pigment Red 254 in the R pixel portion, C. I. Pigment Green 7 and/or 36 in the G pixel portion, and C. I. Pigment Blue 15:6 in the B pixel portion.
4. The liquid crystal display device according to any one of Claims 1 to 3, wherein the R pixel portion further contains at least one organic dye/pigment selected from the group consisting of C. I. Pigment Red 177, 242, 166, 167, and

179, C. I. Pigment Orange 38 and 71, C. I. Pigment Yellow 150, 215, 185, 138, and 139, C. I. Solvent Red 89, C. I. Solvent Orange 56, and C. I. Solvent Yellow 21, 82, 83:1, 33, and 162.

5. The liquid crystal display device according to any one of Claims 1 to 4, wherein the G pixel portion further contains at least one organic dye/pigment selected from the group consisting of C. I. Pigment Yellow 150, 215, 185, and 138, and C. I. Solvent Yellow 21, 82, 83:1, and 33.
6. The liquid crystal display device according to any one of Claims 1 to 5, wherein the B pixel portion further contains at least one organic dye/pigment selected from the group consisting of C. I. Pigment Blue 1, C. I. Pigment Violet 23, C. I. Basic Blue 7, C. I. Basic Violet 10, C. I. Acid Blue 1, 90, and 83, and C. I. Direct Blue 86.
7. The liquid crystal display device according to any one of Claims 1 to 6, wherein the color filter includes a black matrix, RGB three-color pixel portions, and a Y pixel portion, and contains, as a colorant in the Y pixel portion, at least one yellow organic dye/pigment selected from the group consisting of C. I. Pigment Yellow 150, 215, 185, 138, and 139, and C. I. Solvent Yellow 21, 82, 83:1, 33, and 162.
8. The liquid crystal display device according to any one of Claims 1. to 7, wherein the liquid crystal composition layer includes a liquid crystal composition containing at least one compound represented by general formula (LC5),

[Chem. 3]

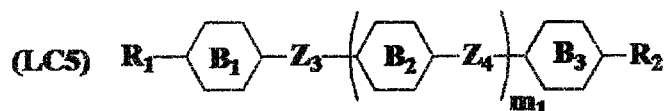

(in the formula, R_1 and R_2 each independently represent an alkyl group having 1 to 15 carbon atoms, at least one CH_2 group in the alkyl group may be substituted by $-O-$, $-CH=CH-$, $-CO-$, $-OCO-$, $-COO-$, $-C\equiv C-$, $-CF_2O-$, or $-OCF_2-$ so that oxygen atoms are not directly adjacent to each other, at least one hydrogen atom in the alkyl group may be arbitrarily substituted by a halogen, B_1 to B_3 each independently represent any one of the following,

[Chem. 4]

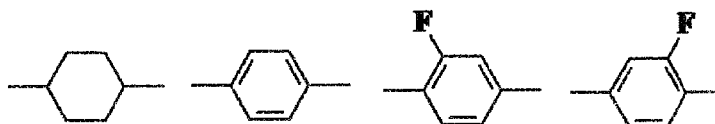

(in the formulae, at least one CH_2CH_2 group in a cyclohexane ring may be substituted by $-CH=CH-$, $-CF_2O-$, or $-OCF_2-$, and at least one CH group in a benzene ring may be substituted by a nitrogen atom), Z_3 and Z_4 each independently represent a single bond, $-CH=CH-$, $-C\equiv C-$, $-CH_2CH_2-$, $-(CH_2)_4-$, $-COO-$, $-OCH_2-$, $-CH_2O-$, $-OCF_2-$, or $-CF_2O-$, at least one of Z_1 and Z_2 is not a single bond, and m_1 represents 0 to 3).

9. The liquid crystal display device according to any one of Claims 1 to 8, wherein the general formula (LC1) represents at least one compound selected from the group consisting of compounds represented by general formula (LC1) -1 to general formula (LC2) -7,

[Chem. 5]

5

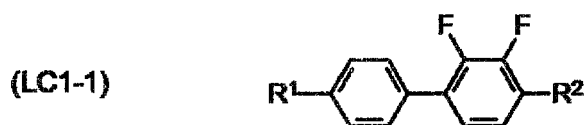

10

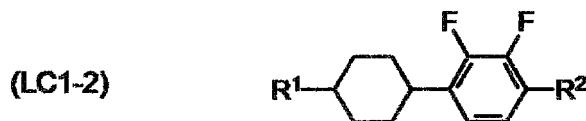

15

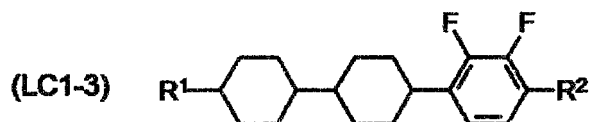

20

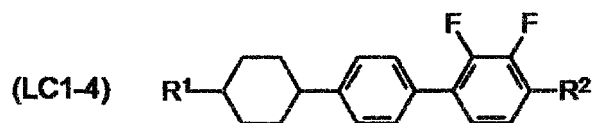

25

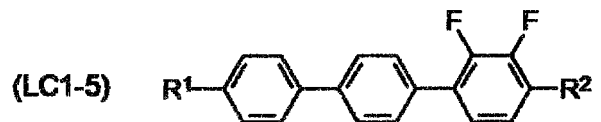

30

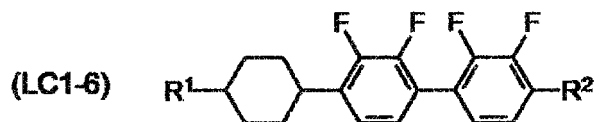

35

(in the formulae, R₁ and R₂ each independently represent an alkyl group having 1 to 7 carbon atoms, an alkoxy group having 1 to 7 carbon atoms, an alkenyl group having 2 to 7 carbon atoms, or an alkenyloxy group having 2 to 7 carbon atoms).

40

10. The liquid crystal display device according to any one of Claims to 9, wherein the general formula (LC2) represents at least one compound selected from the group consisting of compounds represented by general formula (LC2) -1 to general formula (LC2) -15,

45

50

55

[Chem. 6]

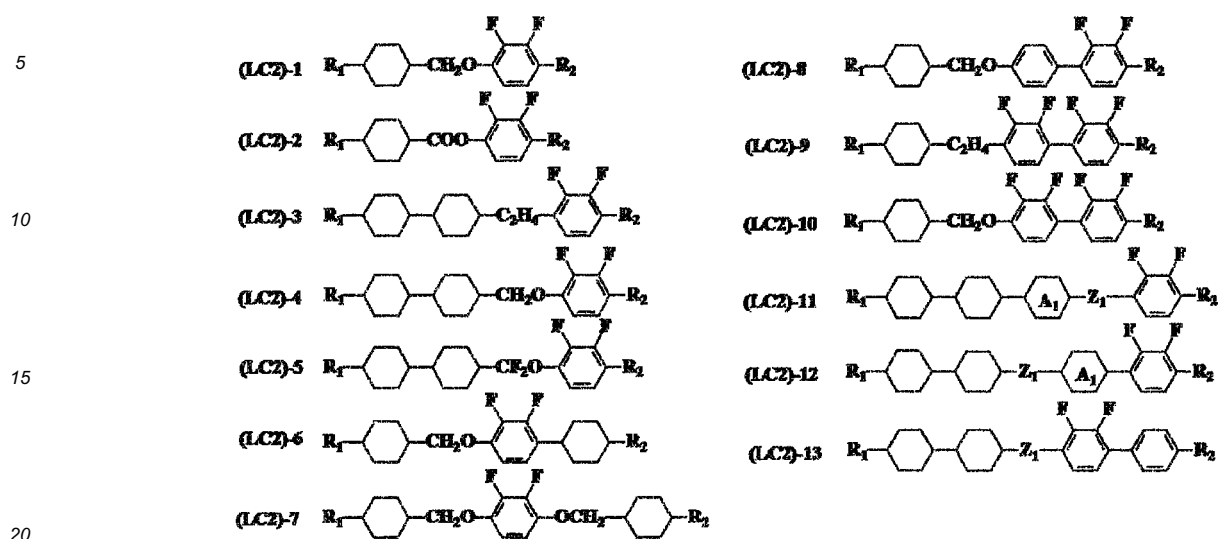

[Chem. 7]

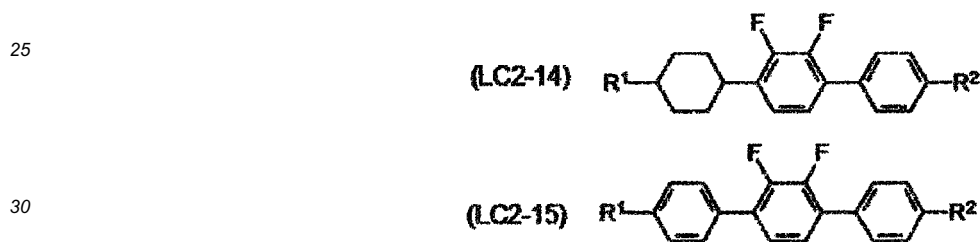

(in the formulae, R₁ and R₂ each independently represent an alkyl group having 1 to 7 carbon atoms, an alkoxy group having 1 to 7 carbon atoms, an alkenyl group having 2 to 7 carbon atoms, or an alkenyloxy group having 2 to 7 carbon atoms, Z₁ represents -CH₂CH₂-, -OCH₂-, -CH₂O-, -OCF₂-, or -CF₂O-, and A¹ represents any one of the following structures).

[Chem. 8]



45 11. The liquid crystal display device according to any one of Claims 1 to 10, wherein the general formula (LC3) represents at least one compound selected from the group consisting of compounds represented by general formula (LC3) -1 to general formula (LC3) -6 below, and the general formula (LC4) represents at least one compound selected from the group consisting of compounds represented by general formula (LC4) -1 to general formula (LC4) -4,

50

[Chem. 9]

55

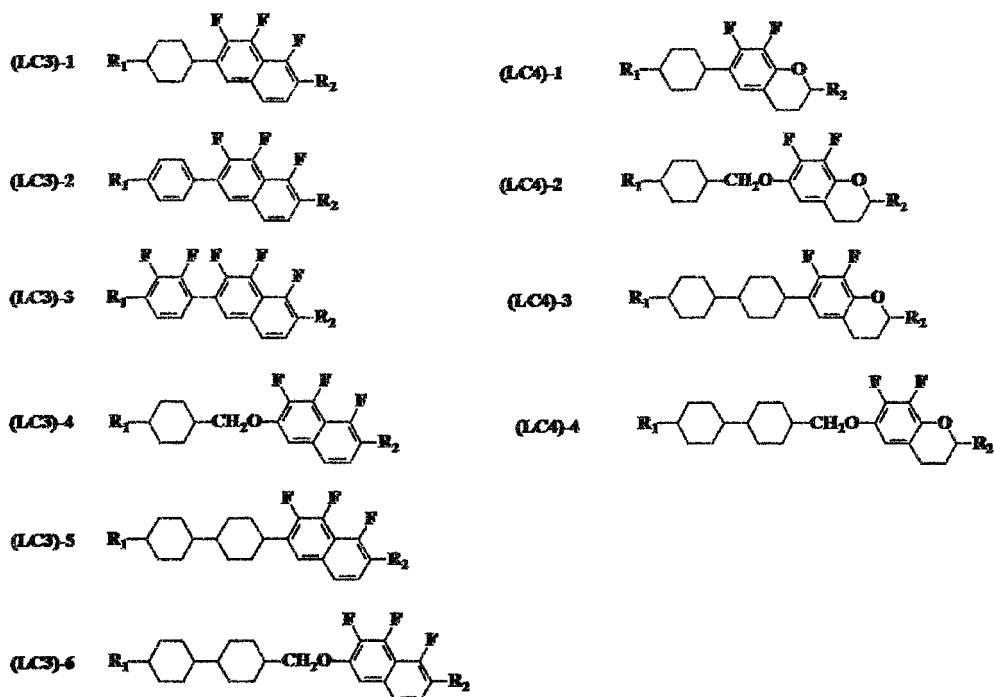

(in the formulae, R₁ and R₂ each independently represent an alkyl group having 1 to 7 carbon atoms, an alkoxy group having 1 to 7 carbon atoms, an alkenyl group having 2 to 7 carbon atoms, or an alkenyloxy group having 2 to 7 carbon atoms).

- 30 12. The liquid crystal display device according to any one of Claims 1 to 11, wherein the general formula (LC5) represents at least one compound selected from the group consisting of compounds represented by general formula (LC5) -1 to general formula (LC5) -13,

35 [Chem. 10]

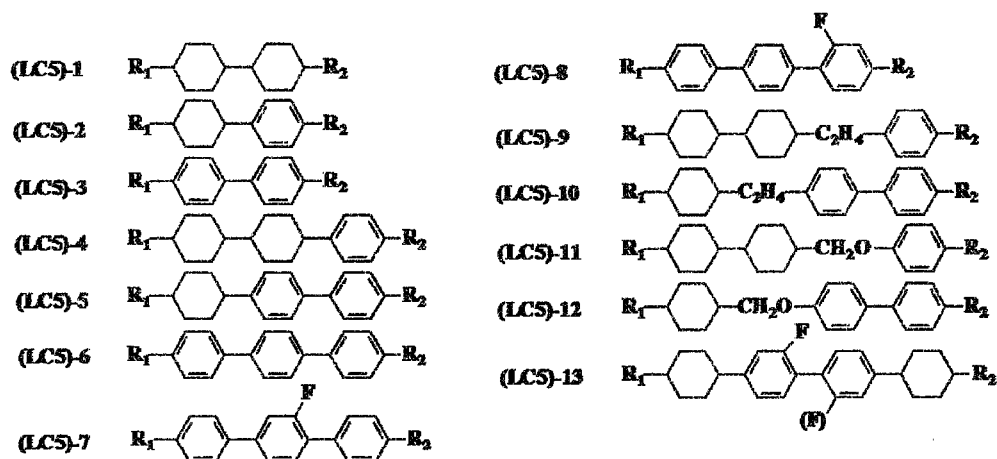

(in the formulae, R₁ and R₂ each independently represent an alkyl group having 1 to 7 carbon atoms, an alkoxy group having 1 to 7 carbon atoms, an alkenyl group having 2 to 7 carbon atoms, or an alkenyloxy group having 2 to 7 carbon atoms).

13. The liquid crystal display device according to any one of Claims 1 to 12, wherein the liquid crystal composition layer

includes a polymer produced by polymerizing a liquid crystal composition containing at least one polymerizable compound.

5 14. The liquid crystal display device according to Claim 13, wherein the polymerizable compound is a disk-shaped liquid crystal compound having a structure in which a benzene derivative, a triphenylene derivative, a truxene derivative, a phthalocyanine derivative, or a cyclohexane derivative serves as a central mother nucleus of a molecule and is radially substituted by linear alkyl groups, linear alkoxy groups, or substituted benzyloxy groups as side chains.

10 15. The liquid crystal display device according to Claim 13, wherein the polymerizable compound is a polymerizable compound represented by general formula (PC1),
[Chem. 11]

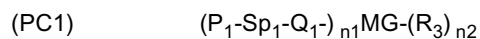

15 (in the formula, p_1 represents a polymerizable functional group, Sp_1 represents a spacer group having 0 to 20 carbon atoms, Q_1 represents a single bond, -O-, -NH-, -NHCOO-, -OCONH-, -CH=CH-, -CO-, -COO-, -OCO-, -OCOO-, -OOCO-, -CH=CH-, -CH=CH-COO-, -OCO-CH=CH-, or -C≡C-, n_1 and n_2 each represent 1, 2, or 3, MG represents a mesogenic group or a mesogeneity supporting group, R_3 represents a halogen atom, a cyano group, or an alkyl group having 1 to 25 carbon atoms, at least one CH_2 group in the alkyl group may be substituted by -O-, -S-, -NH-,
20 -N(CH₃)-, -CO-, -COO-, -OCO-, -OCOO-, -SCO-, -COS-, or -C≡C- so that oxygen atoms are not directly adjacent to each other, and alternatively R_3 represents $P_2-SP_2-Q_2$ - (wherein P_2 , Sp_2 , and Q_2 represent the same meanings as P_1 , Sp_1 , and Q_1 , respectively).
25
30
35
40
45
50
55

FIG. 1

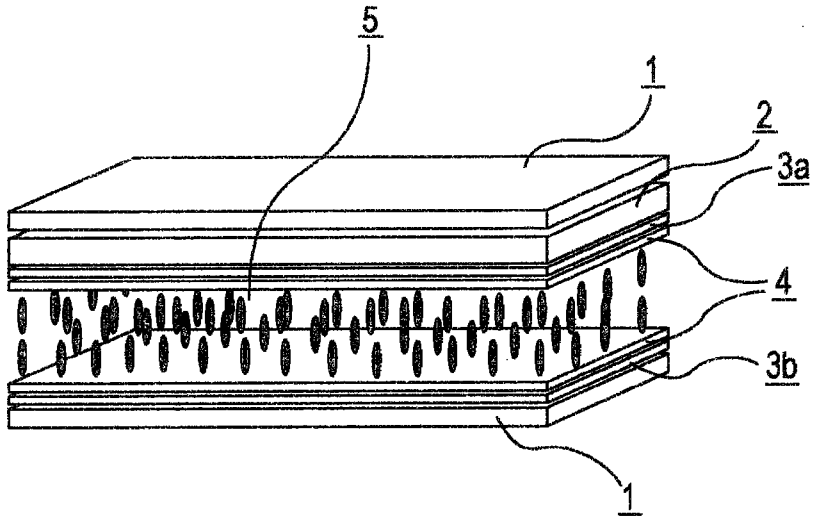
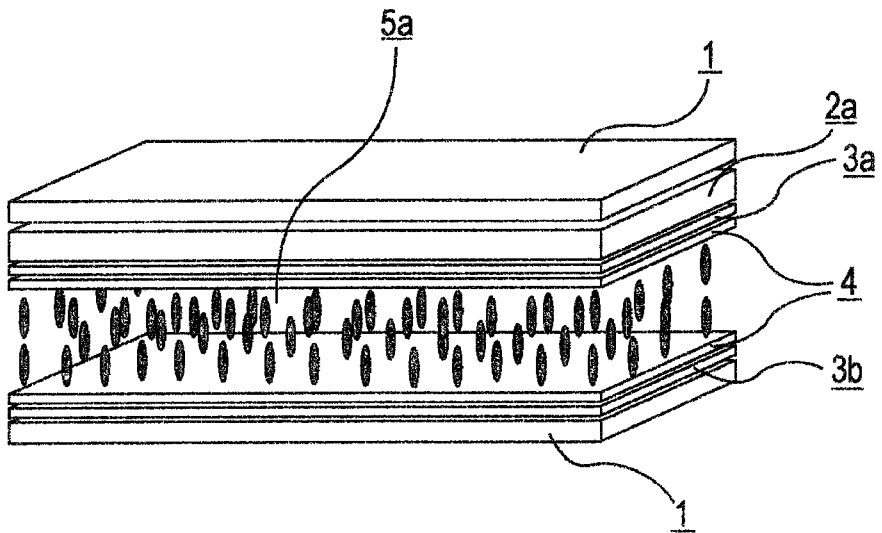

FIG. 2



INTERNATIONAL SEARCH REPORT

International application No.

PCT/JP2012/082521

A. CLASSIFICATION OF SUBJECT MATTER G02F1/1335(2006.01)i, C09K19/12(2006.01)i, C09K19/14(2006.01)i, C09K19/20(2006.01)i, C09K19/30(2006.01)i, C09K19/32(2006.01)i, C09K19/34(2006.01)i, C09K19/38(2006.01)i, G02B5/20(2006.01)i, G02F1/13(2006.01)i According to International Patent Classification (IPC) or to both national classification and IPC		
B. FIELDS SEARCHED Minimum documentation searched (classification system followed by classification symbols) G02F1/1335, C09K19/12, C09K19/14, C09K19/20, C09K19/30, C09K19/32, C09K19/34, C09K19/38, G02B5/20, G02F1/13 Documentation searched other than minimum documentation to the extent that such documents are included in the fields searched Jitsuyo Shinan Koho 1922-1996 Jitsuyo Shinan Toroku Koho 1996-2013 Kokai Jitsuyo Shinan Koho 1971-2013 Toroku Jitsuyo Shinan Koho 1994-2013 Electronic data base consulted during the international search (name of data base and, where practicable, search terms used)		
C. DOCUMENTS CONSIDERED TO BE RELEVANT		
Category*	Citation of document, with indication, where appropriate, of the relevant passages	Relevant to claim No.
A	JP 2000-192040 A (Toshiba Corp.), 11 July 2000 (11.07.2000), entire text (Family: none)	1-15
A	WO 2011/092973 A1 (Chisso Petrochemical Corp.), 04 August 2011 (04.08.2011), entire text (Family: none)	1-15
A	JP 2005-281559 A (Dainippon Ink and Chemicals, Inc.), 13 October 2005 (13.10.2005), entire text (Family: none)	1-15
<input checked="" type="checkbox"/> Further documents are listed in the continuation of Box C. <input type="checkbox"/> See patent family annex.		
* Special categories of cited documents: "A" document defining the general state of the art which is not considered to be of particular relevance "E" earlier application or patent but published on or after the international filing date "L" document which may throw doubts on priority claim(s) or which is cited to establish the publication date of another citation or other special reason (as specified) "O" document referring to an oral disclosure, use, exhibition or other means "P" document published prior to the international filing date but later than the priority date claimed "T" later document published after the international filing date or priority date and not in conflict with the application but cited to understand the principle or theory underlying the invention "X" document of particular relevance; the claimed invention cannot be considered novel or cannot be considered to involve an inventive step when the document is taken alone "Y" document of particular relevance; the claimed invention cannot be considered to involve an inventive step when the document is combined with one or more other such documents, such combination being obvious to a person skilled in the art "&" document member of the same patent family		
Date of the actual completion of the international search 22 February, 2013 (22.02.13)		Date of mailing of the international search report 05 March, 2013 (05.03.13)
Name and mailing address of the ISA/ Japanese Patent Office		Authorized officer
Facsimile No.		Telephone No.

Form PCT/ISA/210 (second sheet) (July 2009)

INTERNATIONAL SEARCH REPORT

International application No.

PCT/JP2012/082521

C (Continuation). DOCUMENTS CONSIDERED TO BE RELEVANT		
Category*	Citation of document, with indication, where appropriate, of the relevant passages	Relevant to claim No.
A	JP 2011-141356 A (Toppan Printing Co., Ltd.), 21 July 2011 (21.07.2011), entire text (Family: none)	1-15
A	JP 2010-189560 A (Toppan Printing Co., Ltd.), 02 September 2010 (02.09.2010), entire text (Family: none)	1-15
A	JP 2006-317602 A (Fujifilm Corp.), 24 November 2006 (24.11.2006), entire text & US 2006/0257763 A1 & KR 10-2006-0116751 A	1-15

Form PCT/ISA/210 (continuation of second sheet) (July 2009)

REFERENCES CITED IN THE DESCRIPTION

This list of references cited by the applicant is for the reader's convenience only. It does not form part of the European patent document. Even though great care has been taken in compiling the references, errors or omissions cannot be excluded and the EPO disclaims all liability in this regard.

Patent documents cited in the description

- JP 2000019321 A [0007]
- JP 2000192040 A [0007]
- JP 20C9109542 B [0007]

专利名称(译)	液晶显示装置		
公开(公告)号	EP2657754A1	公开(公告)日	2013-10-30
申请号	EP2012860188	申请日	2012-12-14
[标]申请(专利权)人(译)	大日本油墨化学工业株式会社		
申请(专利权)人(译)	DIC株式会社		
当前申请(专利权)人(译)	DIC株式会社		
[标]发明人	KANEOYA MASAKAZU TAKEUCHI KIYOFUMI FUNAKURA SEIJI SHIMADA KATSUNORI		
发明人	KANEOYA, MASAKAZU TAKEUCHI, KIYOFUMI FUNAKURA, SEIJI SHIMADA, KATSUNORI		
IPC分类号	G02F1/1335 C09K19/12 C09K19/14 C09K19/20 C09K19/30 C09K19/32 C09K19/34 C09K19/38 G02B5/20 G02F1/13 C09K19/42 C09K19/44		
CPC分类号	G02F1/133514 C09K19/3003 C09K19/3028 C09K19/3066 C09K19/3068 C09K19/322 C09K19/42 C09K19/44 C09K2019/122 C09K2019/123 C09K2019/3004 C09K2019/301 C09K2019/3036 C09K2019/3037 C09K2019/3425		
代理机构(译)	ALBRECHT, THOMAS		
优先权	2011277090 2011-12-19 JP		
其他公开文献	EP2657754A4 EP2657754B1		
外部链接	Espacenet		

摘要(译)

本发明涉及使用特定液晶组合物的液晶显示装置和包含特定染料和/或颜料的滤色器。本发明提供一种液晶显示装置，其能够防止液晶层的电压保持率 (VHR) 的降低和离子密度 (ID) 的增加，并且解决了诸如白点，取向不均匀等显示缺陷的问题，图像残留等。本发明的液晶显示装置的特征在于防止液晶层的电压保持率 (VHR) 降低和离子密度 (ID) 的增加，并且抑制诸如图像残留等显示缺陷的发生。因此，对于用于有源矩阵驱动的VA模式或PSVA模式液晶显示装置特别有用，并且可以应用于液晶电视，监视器，蜂窝电话，智能电话等液晶显示装置。等等。

FIG. 2

