



(11) **EP 1 892 697 B1**

(12) **EUROPEAN PATENT SPECIFICATION**

(45) Date of publication and mention of the grant of the patent:
10.10.2012 Bulletin 2012/41

(51) Int Cl.:
G09G 3/36^(2006.01) G02F 1/1362^(2006.01)
G02F 1/139^(2006.01)

(21) Application number: **07016646.7**

(22) Date of filing: **24.08.2007**

(54) **Liquid crystal display device having delay compensation**

Flüssigkristallanzeigevorrichtung mit Verzögerungskompensation

Dispositif d'affichage à cristaux liquides doté d'une compensation de délai

(84) Designated Contracting States:
DE FR GB NL

(30) Priority: **25.08.2006 KR 20060081056**
08.12.2006 KR 20060124754
15.02.2007 KR 20070015821

(43) Date of publication of application:
27.02.2008 Bulletin 2008/09

(73) Proprietor: **Samsung Electronics Co., Ltd.**
Suwon-si, Gyeonggi-do, 443-742 (KR)

(72) Inventors:
• **Kim, Dong-gyu**
Yongin-si
Gyeonggi-do (KR)

• **Na, Byoung-sun**
Dongtan-myeon,
Hwaseong-si,
Gyeonggi-do (KR)

(74) Representative: **Weitzel, Wolfgang**
Dr. Weitzel & Partner
Patent- und Rechtsanwälte
Friedenstrasse 10
89522 Heidenheim (DE)

(56) References cited:
EP-A- 1 674 922 **JP-A- 4 313 733**
JP-A- 7 218 896 **JP-A- 63 198 022**
US-A- 6 072 550 **US-A1- 2003 227 078**
US-A1- 2004 135 956 **US-A1- 2005 018 121**
US-A1- 2005 179 631 **US-A1- 2006 114 209**

EP 1 892 697 B1

Note: Within nine months of the publication of the mention of the grant of the European patent in the European Patent Bulletin, any person may give notice to the European Patent Office of opposition to that patent, in accordance with the Implementing Regulations. Notice of opposition shall not be deemed to have been filed until the opposition fee has been paid. (Art. 99(1) European Patent Convention).

Description

BACKGROUND

5 Field of Invention

[0001] The present disclosure of invention relates to a liquid crystal display (LCD) device, and more particularly, to a liquid crystal display device in which delay differences of gate signal transmission paths are reduced and brightness uniformity is thereby improved.

10

Description of Related Art

[0002] A typical liquid crystal display device includes a first substrate (TFT-containing substrate) which has a plurality of thin film transistors (TFT's), a second substrate (common electrode substrate) which is in spaced apart facing relation with the first substrate and a liquid crystal material layer which is disposed between the first and second substrates.

15

[0003] Pixel areas of the TFT-containing substrate (first substrate) are typically defined as rectangular areas having corners located at or near where a corresponding gate line and a data line disposed in the TFT substrate cross each other. Light transmission through each pixel area is typically controlled by a thin film transistor (TFT) having its gate connected to the gate line, its source connected to the data line and its drain connected to a corresponding pixel-electrode of the pixel area. When a pixel-activating gate signal, i.e., a gate turn-on voltage (V_{on}), is supplied to the gate line, the thin film transistor is turned on and a data voltage (V_d) appearing at its source is charged to the pixel electrode through the conductive channel region of the TFT.

20

[0004] An electric field which is formed due to the difference between a pixel voltage V_p appearing on the pixel electrode and a common voltage V_{com} appearing on the spaced apart common electrode of the second substrate, drives the liquid crystal material in between to a corresponding optical orientation. In some embodiments, the polarity of the data voltage V_d supplied on the data lines flips with every frame or with predefined numbered ones of frames so as to reduce undesired effects of unidirectional current flow.

25

[0005] A number of factors can cause the V_p voltage appearing on the pixel-electrode to be different than the V_d voltage supplied on the data lines. So-called Miller capacitances or parasitic capacitances, C_p are often present between the gate of each TFT and each of its source and drain electrodes. The rising and falling edges of the data voltage pulse, V_d supplied to the pixel areas via the TFT are stunted (caused to change more slowly) due to negative feedback through the parasitic capacitances C_p , thereby causing a different pixel voltage, V_p to appear on the charged pixel-electrode as compared to the V_d magnitude of the data voltage pulse appearing on the data line. The difference between the magnitude of data voltage V_d supplied on the data line and the pixel voltage V_p developed on the pixel-electrode is referred to as a kick back voltage, V_{kb} .

30

35

[0006] Another factor that affects the pixel-electrode voltage, V_p is the magnitude of the gate turn-on voltage applied to the gate of the TFT. In one class of embodiments, the gate line receives its gate signal from a wider gate signal origination pad, where multiple pads crowd together in a region where a corresponding driving chip (integrated circuit chip) may be disposed and each gate line functions as a separate signal transmission strip for coupling the gate signal from its IC connection pad to individual TFT's distributed along each gate line. Pixel areas which are positioned closer to their respective gate distribution pad generally receive a short-delayed gate signal (delayed due to RC factors) while pixel areas which are positioned farther from the gate pad receive a longer-delayed gate signal due to the cumulative resistance (R) and/or other transmission line effects (i.e., C and/or L) of the gate line.

40

[0007] The size of the kick back voltage V_{kb} depends, among other things, on the delay-producing cumulative resistance of the gate signal. The resulting pixel voltage, V_p is affected by the variation of the kick back voltage V_{kb} , thereby causing irregular brightness in an image due to distance of pixel area from its corresponding gate signal originating pad. These effects may cause undesirable degradation of image quality.

45

JP 04313733 discloses a liquid crystal display device according to the preamble of appended claim 1.

US 2003/0227078 A1 discloses a liquid crystal display device with capacitive or resistive means to compensate the difference in gate lines resistances caused by varying lengths of the fan-out parts from the gate main lines to the respective gate pads.

50

US2006/0114209 A1, US2005/0018121 A1 and US 2004/0135956 A1 each disclose an LCD device having a ballast electric resistor of a zigzag pattern in the fan-out parts from the gate main lines to the respective gate pads in order to compensate the difference in lengths of the gate lines.

55

SUMMARY

[0008] The present invention provides a liquid crystal display device according to appended claim 1 in order to reduce

brightness irregularity due to delay differences between gate signals.

[0009] Additional aspects of the invention are set forth in the appended dependent claims 2-14.

BRIEF DESCRIPTION OF THE DRAWINGS

5

[0010] The above and/or other aspects and advantages of the disclosure will become more readily appreciated from the following detailed description taken in conjunction with the accompanying drawings of which:

[0011] FIG. 1 illustrates plan view of a first substrate in a liquid crystal display device according to a first embodiment;

[0012] FIG. 2 is an enlarged view of a part A in FIG. 1 according to the first embodiment;

10 [0013] FIG. 3 is a sectional view, taken along III-III in FIG 1;

[0014] FIG. 4 graphs a transmissivity attribute as a function of pixel voltage in the liquid crystal display device according to the first embodiment;

[0015] FIG. 5 shows a schematic of an equivalent circuit of a pixel of the liquid crystal display device according to the first embodiment;

15 [0016] FIGS. 6A to 6C illustrate brightness irregularity due to delayed gate signals;

[0017] FIG. 7 is an enlarged view of a part B in FIG. 1 according to the first embodiment;

[0018] FIG. 8 is a sectional view, taken along line VIII-VIII in FIG. 7;

[0019] FIG. 9 illustrates an improvement of brightness irregularity in the liquid crystal display device according to the first embodiment;

20 [0020] FIG. 10 illustrates a relation between delayed gate signals and brightness;

[0021] FIG. 11 illustrates a variation of a parasitic capacitance and brightness;

[0022] FIG. 12 illustrates a delay of the gate signal due to a resistance value of a resistor;

[0023] FIG. 13 illustrates a pixel voltage depending on the resistance value of the resistor;

[0024] FIG. 14 illustrates a circuit diagram of main parts in a liquid crystal display device according to a second exemplary embodiment;

25

[0025] FIG. 15 is an enlarged view of a part C in FIG. 14;

[0026] FIG. 16 illustrates a liquid crystal display device according to a third embodiment;

[0027] FIG. 17 is a sectional view, taken along line XVII-XVII in FIG. 16;

[0028] FIG. 18 is an equivalent circuit of a pixel in a liquid crystal display device according to a fourth embodiment;

30 [0029] FIG. 19 illustrates a principle of improving visibility in the liquid crystal display device according to the fourth embodiment;

[0030] FIG. 20 illustrates an arrangement of the liquid crystal display device according to the fourth embodiment; and

[0031] FIG. 21 illustrates an arrangement of a liquid crystal display device according to a fifth embodiment.

[0032] DETAILED DESCRIPTION OF EMBODIMENTS

35

[0033] Hereinafter, embodiments in accordance with the disclosure will be described with reference to accompanying drawings, wherein like numerals often refer to like elements and repetitive descriptions may then be avoided where practical.

[0034] Hereinafter, discussion regarding forming a first film (i.e., a layer) "on" or "above" a second film (i.e., a layer) is to be understood as covering situations where a third layer is disposed between the two films (i.e., layers) as well as that where the two films (i.e., layers) directly contact each other.

40

[0035] A liquid crystal display device according to the present disclosure will be described with reference to FIGS. 1 to 3.

[0036] A liquid crystal display device 1 (Fig. 3) includes a first substrate 100 which has a thin film transistor T, a second substrate 200 which is spaced apart from and faces the first substrate 100, a liquid crystal material layer 300 which is disposed between the first and second substrates 100 and 200 and a sealant ring 400 (Fig. 1) which sealably joins the first and second substrates 100 and 200 to one another in spaced apart relation.

45

[0037] The first substrate 100 includes a display region and a non-display region which surrounds the display region. A gate main line 121 of the display region is connected with a gate pad 124 through a fan-out part 123 of the non-display region.

[0038] Hereinafter, the first substrate 100 according to the first embodiment will be described.

50

[0039] A gate signal is transmitted from a signal origination pad (e.g., IC connection pad, see 124 of Fig. 7) to gate electrode over a gate wire where the latter wire is formed on a first insulating substrate 111. The gate wire may include a single or plural metal layers. The gate wire generally includes the gate main line 121 which is disposed in the display region and extends transversely, the gate electrode 122 which is connected with the gate main line 121, the fan-out part 123 which extends from the gate main line 121 to the non-display region, and the gate pad 124 which is connected with an end part of the fan-out part 123. A storage electrode line 125 often extends in parallel with the gate main line 121 as seen for example in Fig. 2.

55

[0040] The gate signal origination pad 124 is often connected with a packaging terminal or IC pin of a gate driver circuit (not shown) that outputs the gate signal to the pad end of the gate wire. The gate pad 124 has a substantially wider

width than the gate main line 121 that connects that signal sourcing pad 124 to the gates of TFT's distributed along the gate main line 121.

[0041] A gate insulating layer 131 which in one embodiment is made of a silicon nitride (SiN_x) overlaps the gate electrode 122 and the gate wire 121 where the latter (121, 122) are disposed on the first insulating substrate 111.

[0042] A semiconductor layer 132 which in one embodiment includes amorphous silicon (a-Si) is formed on the gate insulating layer 131 overlapping the gate electrode 122. An ohmic contact layer 133 which in one embodiment includes n+ hydrogenated amorphous silicon highly doped with an n-type dopant is formed on the semiconductor layer 132. The ohmic contact layer 133 is selectively removed (etched away) from a channel between a source electrode 142 and a drain electrode 143 of the TFT (T).

[0043] A data carrying wire is formed to extend over the drain's ohmic contact layer 133 and on top of the gate insulating layer 131. The data wire may include a single or multiple layers of metal. The data wire includes a data line 141 which is shown extending vertically in Fig. 2 and crosses the gate main line 121 at a corner portion of the pixel area. The source electrode 142 branches out from the data line 141 and extends over the ohmic contact layer 133. The drain electrode 143 which is separated from the source electrode 142, extends over the ohmic contact layer 133 opposite to the source electrode 142. A fan-out part 144 of the source line extends from the data main line 141 to the non-display region and a data drive pad 145 (belonging to a data driving circuit or IC, not shown) which is connected with an end of the fan-out part 144.

[0044] The data pad 145 is connected with a data driver circuit (not shown) and receives a data driving signal. The data pad 145 has a wider width than the data main line 141.

[0045] A passivation layer 151 is formed on the data wire and the semiconductor layer 132 that is not covered by the data wire. A contact hole 152 is formed on the passivation layer 151 to expose the drain electrode 143 therethrough. As shown in FIGS. 7 and 8, contact holes 153, 154 and 155 are also formed on the passivation layer 151. The gate insulating layer 131 is removed from the contact holes 153, 154 and 155.

[0046] A pixel electrode 161 is formed on the passivation layer 151. The pixel electrode 161 is typically made of a transparent conductive material such as indium tin oxide (ITO), indium zinc oxide (IZO), etc. The pixel electrode 161 is connected with the drain electrode 143 through the contact hole 152. A pixel electrode splitting pattern 166 is defined (cut through) the pixel electrode 161 as shown.

[0047] The pixel electrode cutting pattern 166 of the pixel electrode 161 divides the liquid crystal layer 300 into a plurality of regions, together with a common electrode cutting pattern 252 (to be described later).

[0048] Hereinafter, the second substrate 200 of the liquid crystal display device 1 according to the first embodiment will be described.

[0049] A black matrix 221 is formed on a second insulating substrate 211. The black matrix 221 generally outlines a corresponding red, green or blue filter 231 and blocks light from being directly emitted through the area of the underlying thin film transistor (T) of the first substrate 100. The black matrix 221 may include a photoresist organic material added with a black pigment. The black pigment may include carbon black or titanium oxide.

[0050] A color filter 231 may include a bandpassing optical material such as one of red, green and blue filters that are repeatedly formed between areas of the black matrix 221. The color filter 231 assigns color to light emitted from a backlight unit (not shown) and traveling through the liquid crystal layer 300. The color filter 231 typically includes a photoresist organic material.

[0051] An overcoat, planarizing layer 241 is typically formed on the color filter 231 and the black matrix 221. The overcoat layer 241 provides planar surface even though the filter and matrix are of different thicknesses and the overcoat layer 241 protects the color filter 231. The overcoat layer 241 may include a photoresist acrylic resin.

[0052] A common electrode 251 is formed on the overcoat layer 241. The common electrode 251 includes a transparent conductive material such as indium tin oxide (ITO), indium zinc oxide (IZO), etc. The common electrode 251 supplies a voltage to one side of the liquid crystal material layer 300, while the pixel electrode 161 of the thin film transistor substrate provides a second voltage to the other side so as to establish one or more electric field patterns through the liquid crystal material layer 300.

[0053] The common electrode cutting pattern 252 is formed on the common electrode 251. The common electrode cutting pattern 252 divides the liquid crystal layer 300 into a plurality of regions together with the pixel electrode cutting pattern 166 of the pixel electrode 161. The pixel electrode cutting pattern 166 and the common electrode cutting pattern 252 are not limited to the V-shaped ones illustrated for the first embodiment, and may be, otherwise, formed in various shapes. In another embodiment of the present disclosure, a protrusion may be provided to divide the liquid crystal layer 300 into a plurality of regions instead of the cutting patterns 166 and 252.

[0054] The liquid crystal layer 300 is disposed between the first and second substrates 100 and 200. In one embodiment, the liquid crystal material layer 300 is a vertically aligned (VA) mode, in which a long axis of liquid crystal molecules is perpendicular to the first and second substrates 100 and 200 if not receiving a voltage. When receiving a driving voltage, the long axis of the liquid crystal molecules shift to lie in a vertical direction with respect to an electric field due to negative dielectric anisotropy.

[0055] If the cutting patterns 166 and 252 are not formed, the liquid crystal molecules may lie irregularly in all directions since the lying direction is not determined by boundary conditions, thereby creating a disclination line on a boundary between different lying directions. The cutting patterns are organized 166 and 252 to form a fringe electric field when a voltage is supplied to the liquid crystal layer 300 and to thereby determine the lying direction of the liquid crystal molecules.

The liquid crystal layer 300 is divided into plural regions by the cutting patterns 166 and 252.

[0056] The liquid crystal display device 1 according to the first embodiment has a normally black mode when no substantial voltage is applied across the liquid crystal material, and a transmissivity that is a function of the pixel voltage as is illustrated in the plot of FIG. 4. The transmissivity variation in a low gradation shown in a part C in FIG. 4 is three times more drastic for the VA material than a twisted nematic liquid crystal.

[0057] In the liquid crystal display device 1 according to the first embodiment, the gate main line 121 receives a gate signal through the gate pad 124 connected with the end part thereof. Due to a resistance of the gate main line 121, the thin film transistor T adjacent to the gate pad 124, i.e., a left thin film transistor T receives a short-delayed gate signal but the thin film transistor T far from the gate pad 123, i.e., a right thin film transistor T receives a longer-delayed gate signal.

[0058] Variations in image brightness depending on delay differences of the gate signals are described with reference to FIGS. 5 to 6C.

[0059] The kick back voltage V_{kb} may be expressed by a formula 1 as follows.

[0060] Formula 1

[0061]

$$V_{kb} = (V_{on} - V_{off}) * C_p / (C_{lc} + C_{st} + C_p)$$

[0062] As shown in FIGS. 3 and 5, C_p refers to combined parasitic capacitance C_{gs} between the gate electrode and the source electrode and a parasitic capacitance C_{gd} between the gate electrode and the drain electrode, C_{lc} is a liquid crystal capacitance, C_{st} is a storage capacitance, V_{on} is a gate on voltage and V_{off} means a gate turn-off voltage.

[0063] If the gate signal is delayed longer relative to a data pulse on the data line, the gate-on voltage (V_{on}) is not supplied in time, thereby decreasing the kick back voltage V_{kb} . The kick back voltage V_{kb} becomes larger when a negative pixel voltage is supplied rather than when a positive pixel voltage is supplied.

[0064] FIGS. 6A and 6B respectively illustrate a kick back voltage V_{kb} of a pixel in a left-side display region having a short-delayed gate signal, and a pixel in a right-side display region having a longer-delayed gate signal.

[0065] Regarding the left-side pixel in FIG. 6A, the kick back voltage is about 1.0V when the positive pixel voltage is supplied while it is about 1.2V when the negative pixel voltage is supplied. Concerning the right-side pixel in FIG. 6B, the kick back voltage is about 0.8V when both the positive pixel voltage and the negative pixel voltage are supplied.

[0066] As a result, the left-side pixel has a larger root mean square pixel voltage that remains ultimately, and an image corresponding to the left-side pixel is seen as being comparatively brighter.

[0067] As shown in FIG. 6C, the gate signal is shorter-delayed and the kick back voltage V_{kb} becomes larger if they are closer to the gate pad 124. Conversely, the gate signal is longer-delayed and the kick back voltage V_{kb} becomes smaller if they are farther from the gate pad 124. Thus, the left-side pixel has a larger root mean square pixel voltage than the right pixel to brighten the image corresponding to the left pixel more than that corresponding to the right pixel.

[0068] As described above, brightness is different from left and right sides, thereby sometimes showing as an unintended vertical line. Such a problem is more serious in a large-sized liquid crystal display device which has a long gate main line 121 and causes a longer-delayed gate signal.

[0069] Referring to Fig. 7, the liquid crystal display device 1 according to the first embodiment of the present disclosure provides a compensating resistor 163 disposed between the gate main line 121 and the fanout line 123 (and the gate pad 124) to reduce the above-mentioned problem.

[0070] Hereinafter, the resistor 163 of the liquid crystal display device 1 according to the first embodiment will be described with reference to FIGS. 7 to 9.

[0071] The resistor 163 is disposed between the fan-out part 123 and the gate main line 121 in the non-display region. The primary resistive material of resistor 163 is provided by the same layer that provides the primary material of the pixel electrode 161. The resistor 163 includes a first part 163a which is connected with the fan-out part 123, a second part 163b which is connected with the gate main line 121 and a third part 163c which is electrically disposed between the first and second parts 163a and 163b.

[0072] The first part 163a contacts the fan-out part 123 through the contact hole 154. The second part 163b contacts the gate main line 121 through the contact hole 155.

[0073] The gate pad 124 exposed by the contact hole 153 is covered by a contact member 162, where member 162 is comprised of the same material as that of the pixel electrode 161 and where member 162 is disposed in the same

layer with the pixel electrode 161.

[0074] The resistor 163 can include one or more of optically transmissive electrical conductors such as indium tin oxide (ITO), indium zinc oxide (IZO), etc., which have a larger resistance than an optically opaque electrical conductor such as the metal material used in the gate main line 121. Due to the resistor 163 having a substantially large resistance, the gate signal is substantially delayed before entering the display region, as shown in FIG. 9 and the difference in delay as shown by Figs. 6A-6B is no longer a substantial factor in determining kick back.

[0075] Thus, the scope of delay differences between gate signals and the variation of the kick back voltage are reduced. Also, the brightness differences between the left and right sides of the display region decreases.

[0076] In one class of embodiments, total resistance of the gate main line 121 is typically 4000Ω to 7000Ω while a total resistance of the resistor 163 may be 10% to 50% of the total resistance of the gate main line 121. The resistance value of the resistor 163 may vary by changing one or more of a thickness, width and length attribute of the resistor 163.

[0077] It is preferable but not necessary that the resistance value of the resistor 163 be set so that the gate signal delay variation due to resistance of the main gate line is substantially less than gate signal delay to total wire resistance. In other words, the gate signal delay value of a far right pixel of the display region is no more than about twice the gate signal delay value of the far left pixel in the display region (the one closest to the gate signal originating pad 124).

[0078] The distance between the gate main line 121 and the gate pad 124 is various, thereby causing a different resistance therebetween and irregular brightness.

[0079] The length of the third part 163c in the resistor 163 is in inverse proportion to the distance between the corresponding gate main line 121 and the gate pad 124. Thus, brightness irregularity due to variation in distance between the gate main line 121 and the gate pad 124 decreases.

[0080] As seen in Fig. 8, the sealant 400 is disposed on the fan-out part 123 while the resistor 163 is provided inside the liquid crystal material containing area of the sealant 400. Because the resistor 163 is not exposed to the outside, it is safe from being corroded.

[0081] During a manufacturing process, a flow of static electricity from the outside may damage the thin film transistor T. According to the first embodiment, a substantial portion of the energy of the static electricity flow introduced from the gate pad 124 is dissipated in the resistor 163 having the larger resistance, thereby reducing problems due to static electricity.

[0082] A resistor 163 according to another embodiment of the present disclosure may include other materials having a larger resistance than the gate main line 121 and being different from the material of the pixel electrode 161. In another embodiment of the present disclosure, the shape of the resistor 163 is identical and the distance differences between the gate main line 121 and the gate pad 124 may be dealt with by changing the shape of the fan-out part 123.

[0083] Hereinafter, the reason why the gate signal delay is adjusted to improve the brightness irregularity will be described.

[0084] FIG. 10 illustrates a brightness variation ratio depending on the gate signal delay value in the display region. The brightness variation ratio is defined by the mathematical expression, $BVR = (\text{Brightness of the left display region} - \text{Brightness of central display region}) / (\text{Brightness of central display region}) * 100$. Here, a large value means a large brightness difference.

[0085] As shown in the example of FIG. 10, if the gate signal delay value rises 43% (from $2.55\mu\text{s}$ to $3.67\mu\text{s}$), the brightness variation ratio (BVR) increases around 64% (from 30.6% to 50.3%)

[0086] FIG. 11 illustrates a brightness variation ratio according to $C_p / (C_{1c} + C_{st} + C_p)$ in proportion to the kick back voltage. As shown therein, if $C_p / (C_{1c} + C_{st} + C_p)$ increases 24% (from 0.037 to 0.046), the brightness variation ratio rises approximately 26.4% (from 35.6% to 45%).

[0087] As shown in FIGS. 10 and 11, brightness irregularity (BVR) gets worse as variation in the gate signal delay value gets larger and/or as comparative contribution to kickback from the parasitic capacitance gets larger.

[0088] The comparative amount of gate signal delay relative to position of the pixel electrode can be made to vary by changing a compensating or ballasting resistance in the non-display region, i.e., a resistance from the gate pad to the gate main line, which will be described with reference to the examples of FIGS. 12 and 13.

[0089] As shown therein, the resistance in the non-display region was switched over the following four values: $1/6k\Omega$, $1/3k\Omega$, $1/2k\Omega$ and $2/3k\Omega$. The bottom most data plot having $0k\Omega$ is the case where there is no ballasting resistor and a gate main line and a gate pad are integrally formed in the same layer.

[0090] As shown in FIG. 12, the larger the resistance of the ballasting resistor in the non-display region was, the higher was the cumulative gate signal delay value when moving from the left side of the main line (closest to the gate pad) to the right side of the main line (farthest from the gate signal originating pad). If the resistance of the ballasting resistor in the non-display region becomes larger, the ratio of the right gate signal delay value over the left gate signal delay value decrease. In other words, change in brightness from left to right decreases.

[0091] If the resistance is $0k\Omega$, the positional delay ratio, $PDR = (\text{right gate signal delay value}) / (\text{left gate signal delay value})$ is 6.53 (calculated from $4.18/0.64$). Meanwhile, if the resistance is $2/3k\Omega$, the PDR value is 1.77 (calculated from $8.12/4.57$). Thus it is seen that PDR (the positional delay ratio) decreases substantially as the ballasting resistance

becomes a more predominant factor in total line resistance seen between the gate pad and the gate electrode.

[0092] As shown in FIG. 13, the larger the resistance of the ballasting resistor in the non-display region is, the smaller the overall pixel voltage is. As the resistance of the ballasting resistor becomes larger, the positional voltage ratio, $PVR = (\text{left pixel voltage}) / (\text{right pixel voltage})$ decreases. That is, if the resistance is $0k\Omega$, the ratio, $(\text{left pixel voltage}) / (\text{right pixel voltage})$ is 1.028 (calculated from $3.3 / 3.21$), if the resistance is $2/3k\Omega$, the PVR is 1.012 (calculated from $3.19 / 3.15$).

[0093] As shown in FIGS. 12 and 13, the increased resistance of the ballasting resistor in the non-display region decreases the positionally-related differences in the gate signal delay and the positionally-related differences in the pixel voltage between the left-side display region and the right-side display region. However, if the resistance of the ballasting resistor in the non-display region becomes larger, it also becomes more difficult to transmit a strong gate signal to each TFT. Thus, the resistance of the ballasting resistor should be determined as a compromise and in consideration of the total resistance of the gate main line 121.

[0094] Hereinafter, a liquid crystal display device according to a second exemplary embodiment of the present disclosure will be described with reference to FIGS. 14 and 15. FIG. 14 illustrates a part corresponding B area in FIG. 1.

[0095] As shown in FIG. 14, an anti-static set of diode-connected MOSFETs 170 is formed on an outer circumference portion of each ballasting resistor 163. The anti-static set 170 is electrically connected with a gate outer circumference and a common voltage line 146. If static electricity is introduced through a gate pad 124 during a manufacturing process, the resistor 163 having a large resistance may be damaged, thereby causing disconnection. However, the anti-static set of diode-connected MOSFETs 170 is activated when the absolute value of voltage of the static exceed a predefined threshold and the activated set 170 scatters the introduced static electricity to the common voltage line (e.g., ground) 146 to prevent the resistor 163 from being damaged. The gate outer circumference portion refers a gate wire connected with the gate main line 121 and formed outside of the resistor 163. That is, the gate outer circumference portion includes the gate pad 124 and the fan-out part 123.

[0096] In one embodiment, the anti-static diode means 170 includes a plurality of thin film MOSFET transistors. The anti-static diode means 170 includes a first diode-connected MOSFET 171 and a second diode-connected MOSFET 172 coupled for carrying differently directed current flows. The first diode-connected MOSFET 171 is provided so that a negative going current flows from the gate outer circumference to the common voltage line 146. The second diode-connected MOSFET 172 is provided so that a positive-going current flows from the common voltage line 146 to the gate outer circumference portion.

[0097] Hereinafter, an embodiment of the anti-static diode means 170 will be described in more detail with reference to FIG. 15. The common voltage line 146 serves as an electrostatic bar with respect to the anti-static diode means 170.

[0098] A control terminal (gate) 1711 and an input terminal (drain) 1712 of the first diode-connected MOSFET 171 are connected with each other and with the gate line outer circumference (121). An output terminal (source) 1713 of the first diode-connected MOSFET 171 is connected with the common voltage line 146. A bridge 1714 connects the input terminal (drain) 1712 to the gate outer circumference (121). If static electricity is inputted to the gate outer circumference and the static exceeds the predefined threshold (V_t) of MOSFET 171, the control terminal 1711 connected with the gate outer circumference is switched to a turned on state, MOSFET 171 becomes conductive and thereby diverts the static electricity to the common voltage line 146 connected with the output terminal 1713.

[0099] A control terminal (gate) 1721 and an input terminal (drain) 1722 of the second diode-connected MOSFET 172 are connected with the common voltage line 146. An output terminal (source) 1723 of the second diode-connected MOSFET 172 is connected with the gate outer circumference (121). A second bridge 1724 connects the common voltage line 146 and the control terminal 1721 while a third bridge 1725 connects the output terminal 1723 and the gate outer circumference. If static electricity is inputted to the gate outer circumference and the static exceeds the predefined threshold (V_t) of MOSFET 172, the control terminal 1721 connected with the gate outer circumference through the bridge 1724 is switched to a turned-on state, MOSFET 172 becomes conductive and thereby diverts the static electricity to the common voltage line 146 connected with the input terminal (drain) 1722.

[0100] In another exemplary embodiment, the anti-static diode means 170 may include only a first anti-static diode-connected MOSFET 171 without the second anti-static diode-connected MOSFET 172.

[0101] Hereinafter, a liquid crystal display device according to a third embodiment of the present disclosure will be described with reference to FIGS. 16 and 17.

[0102] A gate pad 164 and a fan-out part 165 according to the third embodiment are integrally formed in a same layer with the ballasting resistor 163. The gate pad 164 and the fan-out part 165 may include indium tin oxide (ITO) or indium zinc oxide (IZO). The resistor 163 is connected with a gate main line 121 through a contact hole 156. The gate pad 164 and the fan-out part 165 perform the same operation as the resistor 163 according to the first embodiment.

[0103] In one embodiment, the resistance of the ballasting resistor 163 is in inverse proportion to a distance between the corresponding gate main line 121 and the gate pad 164 as was the case for one version of the first embodiment. Thus, brightness irregularity due to a distance difference between the gate main line 121 and the gate pad 164 decreases.

[0104] In another embodiment of the present disclosure, only a fan-out part 165 composed of a substantially resistive material such as indium tin oxide (ITO) or indium zinc oxide (IZO) may be provided to delay a corresponding gate signal,

without forming a separate ballasting resistor 163 in the shape of the square waves such as shown in the lower two lines of Fig. 16.

[0105] A liquid crystal display device according to a fourth embodiment will be described with reference to FIGS. 18 to 20.

[0106] As shown in FIG. 18, a thin film transistor T is connected with two liquid crystal capacitances C_{LC1} and C_{LC2} . The first liquid crystal capacitance C_{LC1} is formed between a first pixel electrode PE1 and a common electrode CE. The first pixel electrode PE1 is directly connected with the thin film transistor T. The second liquid crystal capacitance C_{LC2} is formed between the second pixel electrode PE2 and the common electrode CE. The second pixel electrode PE2 is indirectly connected with the thin film transistor T through a coupling capacitance C_{CP} .

[0107] Here, the first pixel electrode PE1 and the second pixel electrode PE2 are electrically separated from each other due to the presence of coupling capacitance C_{CP} and the second liquid crystal capacitance C_{LC2} .

[0108] The liquid crystal display device according to the fourth embodiment can improve visibility per a mechanism which will be described with reference to FIG. 19.

[0109] The first pixel electrode PE1 receives a data signal through the thin film transistor T. Meanwhile, the second pixel electrode PE2 receives a data signal by a voltage through a coupling capacitance C_{CP} formed in an insulating layer between the second pixel electrode PE and the thin film transistor T, instead of directly receiving the data signal from the thin film transistor T.

[0110] Thus, the second pixel electrode PE2 receives a weaker signal than the first pixel electrode PE1, thereby causing a difference in brightness of the pixel region corresponding to the first pixel electrode PE1 and the pixel region corresponding to the second pixel electrode PE2. In one embodiment, the voltage supplied to the second pixel electrode PE2 is 50% to 90% of the voltage supplied to the first pixel electrode PE1.

[0111] Thus, a single pixel has a plurality of regions that have different gamma curves. The brightness and color in a front and lateral parts are compensated to improve lateral visibility.

[0112] As shown in FIG. 20, the pixel electrode 161 includes a first pixel electrode 161a and a second pixel electrode 161b which are separated from each other by a pixel electrode separating pattern 167. The second pixel electrode 161b has a trapezoid shape whose three sides are surrounded by the first pixel electrode 161a. A pixel electrode cutting pattern 166 which is side by side with the pixel electrode separating pattern 167 is formed on the first and second pixel electrodes 161a and 161b.

[0113] A drain electrode 143 includes a first drain electrode 143a which is connected with the first pixel electrode 161a and supplies an electrical signal thereto and a second drain electrode 143b which extends below the second pixel electrode 161b. The second drain electrode 143b forms a coupling capacitance C_{CP} together with the second pixel electrode 161b.

[0114] The pixel electrode separating pattern 167 and the pixel electrode cutting pattern 166 divide a liquid crystal layer 300 into a plurality of regions together with a common electrode cutting pattern 252.

[0115] A storage electrode line 125 is formed along the boundary of the pixel electrode 161. Upper and lower storage electrode lines 125 are connected with each other through a contact hole 157 and a bridge electrode 168.

[0116] A liquid crystal display device according to a fifth embodiment of the present disclosure will be described with reference to FIG. 21.

[0117] A pixel electrode 161 has a rectangular shape as a whole. The pixel electrode 161 is elongated in an extension direction of a data line 141.

[0118] The pixel electrode 161 includes a first pixel electrode 161a and a second pixel electrode 161b which are separated from each other by a pixel electrode separating pattern 167. The first pixel electrode 161a is disposed in a center of a pixel and has a chevron-shape. The second pixel electrode 161b surrounds an inside, an upper part and a lower part of the first pixel electrode 161a. The second pixel electrode 161b is larger than the first pixel electrode 161a.

[0119] A thin film transistor T includes a first thin film transistor TFT1 which is connected with the first pixel electrode 161a and a second thin film transistor TFT2 which is connected with the second pixel electrode 161b.

[0120] A drain electrode 143 of the respective thin film transistors TFT1 and TFT2 overlaps the pixel electrode 161 to form a storage capacitance Cst. The storage capacitance Cst is proportional to an overlapping size of the drain electrode 143 and the pixel electrode 161.

[0121] In the fifth embodiment, respective pixel electrodes 161a and 161b receive different pixel voltages by using independent thin film transistors TFT1 and TFT2. The method of improving visibility in the fifth embodiment is the same as that in the fourth embodiment. Thus the detailed description will not be provided here.

[0122] The configuration of the non-display region in the fourth and fifth embodiments can be the same as that in the first to third embodiment of the present disclosure.

[0123] As the pixel electrode 161 is divided in the fourth and fifth embodiments, the liquid crystal capacitance C_{LC} and the storage capacitance Cst are small. Thus, the kick back voltage V_{kb} becomes larger, thereby making the brightness difference (refer to Formula 1) more significant.

[0124] As described above, the present disclosure of invention provides a liquid crystal display device which reduces a brightness irregularity due to a gate signal delay difference.

[0125] Although a number of embodiments have been shown and described, it will be appreciated by those skilled in the art after studying the above that changes may be made in these embodiments without departing from the scope of the appended claims.

5

Claims

1. A liquid crystal display device (1) comprising:

10 a first substrate (100) having a display region surrounded by a non-display region;
 a second substrate (200) spaced apart from and facing the first substrate (100);
 a sealant ring (400) sealably joining the first and second substrates (100, 200) to one another in said spaced
 apart relation; and
 a liquid crystal material layer (300) disposed between the first substrate (100), the second substrate (200) and
 15 the sealant ring (400);
 the first substrate (100) comprising:

gate main lines (121) which are disposed in the display region;
 gate pads (124; 164) which are disposed in the non-display region outside the display region; and
 20 each gate main line (121) being connected to a corresponding gate pad (124; 164) via a respective con-
 ductive fan-out line (123; 144; 165) and a respective electric ballast resistor (163) both disposed in the non-
 display region,

wherein each electric ballast resistor (163) is formed of one or more optically transmissive and electrically
 25 conductive materials having a larger electrical resistivity than that of the optically opaque and electrically con-
 ductive material used for forming the gate main lines (121);

characterized in that

the gate main lines (121), the gate pads (124; 164) and the fan-out lines (123; 144; 165) are formed in the same
 layer, and
 30 the sealant ring (400) is formed on the fan-out lines (123), and each electric ballast resistor (163) is provided
 inside an area of the first substrate (100) surrounded by the sealant ring (400) in plan-view.

2. The liquid crystal display device (1) according to Claim 1, wherein the first substrate (100) further comprises thin
 film transistors (T) each of which is electrically connected with a respective gate main line (121), and pixel electrodes
 35 (161) each of which is electrically connected with a respective thin film transistor (T).

3. The liquid crystal display device (1) according to claim 2, wherein each electric ballast resistor (163) comprises the
 same material as the pixel electrodes (161).

40 4. The liquid crystal display device (1) according to claim 3, wherein each electric ballast resistor (163) comprises
 indium tin oxide (ITO) or indium zinc oxide (IZO).

5. The liquid crystal display device (1) according to claim 1, wherein the first substrate (100) further comprises an
 electrostatic bar (146) which crosses the gate outer circumference, the gate outer circumference denoting the gate
 45 wiring connected to the gate main lines (121) except for the electric ballast resistors (163) but including the gate
 pads (124; 164) and the gate fan-out lines (123; 144; 165), wherein the first substrate (100) further comprises an
 anti-static diode (170) which is electrically connected with the gate outer circumference and the electrostatic bar (146).

6. The liquid crystal display device (1) according to claim 5, wherein the first substrate (100) further comprises a storage
 50 electrode line (125) which is formed within the display region and is elongated in parallel with the gate main lines
 (121), and a common voltage line (146) which is formed outside the display region and crosses the gate circumfer-
 ence, and is arranged to supply a common voltage to the storage electrode line (125), and the electrostatic bar
 (146) comprises the common voltage line (146).

7. The liquid crystal display device (1) according to claim 5, wherein the anti-static diode (170) comprises a first anti-
 static diode (171) which has the gate outer circumference as a control terminal (1711) and an input terminal (1712),
 and the electrostatic bar as an output terminal (1713), and a second anti-static diode (172) which has the gate outer
 55 circumference as an output terminal (1723), and the electrostatic bar as a control terminal (1721) and an input

terminal (1722).

8. The liquid crystal display device (1) according to claim 2, wherein the liquid crystal layer (300) is vertically aligned.

5 9. The liquid crystal display device (1) according to claim 8, wherein each pixel electrode (161) comprises a pixel electrode cut-out pattern (166) and the second substrate (200) comprises a common electrode (251) which is formed with a common electrode cut-out pattern (252).

10 10. The liquid crystal display device (1) according to claim 9, wherein each pixel electrode (161) comprises a first pixel electrode (161a) and a second pixel electrode (161b) which are separated from each other, and the first and second pixel electrodes (161 a; 161b) are arranged to receive different pixel voltages.

15 11. The liquid crystal display device (1) according to claim 10, wherein each thin film transistor (T) comprises a drain electrode (143) which comprises a first drain electrode (143a) supplying a data voltage directly to the first pixel electrode (161a) and a second drain electrode (143b) forming a coupling capacitance together with the second pixel electrode (161b).

20 12. The liquid crystal display device (1) according to claim 10, wherein each thin film transistor (T) comprises a first thin film transistor (TFT1) which is connected with the first pixel electrode (161a) and a second thin film transistor (TFT2) which is connected with the second pixel electrode (161b).

13. The liquid crystal display device (1) according to claim 1, wherein a total resistance of each electric ballast resistor (163) is 10% to 50% of a total resistance of the respective gate main line (121).

25 14. The liquid crystal display device (1) according to claim 1, wherein the resistance value of each electric ballast resistor (163) is set so that the variation of a gate signal delay due to resistance of the respective gate main line (121) is substantially less than the gate signal delay due to total wire resistance.

30 **Patentansprüche**

1. Flüssigkristallanzeigevorrichtung (1), umfassend:

35 ein erstes Substrat (100) mit einem von einem Nichtanzeigebereich umgebenen Anzeigebereich;
 ein zweites Substrat (200), das vom ersten Substrat (100) beabstandet und diesem zugewandt ist;
 einen Dichtungsring (400), der das erste und das zweite Substrat (100, 200) in dem beabstandeten Verhältnis zueinander dichtend verbindet; und eine Flüssigkristallmaterialschicht (300), die zwischen dem ersten Substrat (100), dem zweiten Substrat (200) und dem Dichtungsring (400) angeordnet ist;
 wobei das erste Substrat (100) umfasst:

40 Gate-Hauptleiter (121), die in den Anzeigebereichen angeordnet sind;
 Gate-Pads (124; 164), die im Nichtanzeigebereich außerhalb des Anzeigebereichs angeordnet sind;
 und wobei jeder Gate-Hauptleiter (121) über einen zugehörigen leitenden Fan-out-Leiter (123; 144; 165) und einen zugehörigen elektrischen Vorschaltwiderstand (163), die beide im Nichtanzeigebereich angeordnet sind, mit einem entsprechenden Gate-Pad (124; 164) verbunden sind;
 wobei jeder elektrische Vorschaltwiderstand (163) aus einem oder mehreren lichtdurchlässigen und elektrisch leitenden Materialien gebildet ist, die einen höheren elektrischen Widerstand aufweisen als das lichtundurchlässige und elektrisch leitende Material, das zur Ausbildung der Gate-Hauptleiter (121) verwendet wird;

50 **dadurch gekennzeichnet, dass**

die Gate-Hauptleiter (121), die Gate-Pads (124; 164) und die Fan-out-Leiter (123; 144; 165) in derselben Schicht ausgebildet sind, und dass der Dichtungsring (400) auf den Fan-out-Leitern (123) ausgebildet ist und jeder elektrische Vorschaltwiderstand (163) innerhalb eines Bereichs des ersten Substrats (100) vorgesehen ist, der in Draufsicht vom Dichtungsring (400) umgeben ist.

55 2. Flüssigkristallanzeigevorrichtung (1) gemäß Anspruch 1, wobei das erste Substrat (100) ferner Dünnschichttransistoren (T), deren jeder elektrisch mit einem zugehörigen Gate-Hauptleiter (121) verbunden ist, und Pixelelektroden (161) umfasst, deren jede mit einem zugehörigen Dünnschichttransistor (T) elektrisch verbunden ist.

3. Flüssigkristallanzeigevorrichtung (1) gemäß Anspruch 2, wobei jeder elektrische Vorschaltwiderstand (163) dieselben Materialien wie die Pixelelektroden (161) umfasst.
- 5 4. Flüssigkristallanzeigevorrichtung (1) gemäß Anspruch 3, wobei jeder elektrische Vorschaltwiderstand (163) Indiumzinnoxid (ITO) oder Indiumzinkoxid (IZO) umfasst.
- 10 5. Flüssigkristallanzeigevorrichtung (1) gemäß Anspruch 1, wobei das erste Substrat (100) ferner einen elektrostatischen Stab (146) umfasst, der den Gate-Außenumfang kreuzt, wobei der Gate-Außenumfang die mit den Gate-Hauptleitern (121) verbundene Gate-Verdrahtung markiert, ausgenommen die elektrischen Vorschaltwiderstände (163) aber einschließlich der Gate-Pads (124; 164) und der Gate-Fan-out-Leiter (123; 144; 165), wobei das erste Substrat (100) ferner eine antistatische Diode (170) umfasst, die elektrisch mit dem Gate-Außenumfang und dem elektrostatischen Stab (146) verbunden ist.
- 15 6. Flüssigkristallanzeigevorrichtung (1) gemäß Anspruch 5, wobei das erste Substrat (100) ferner einen Speicherelektrodenleiter (125), der innerhalb des Anzeigebereichs ausgebildet und parallel zu den Gate-Hauptleitern (121) verlängert ist, und einen gemeinsamen Spannungsleiter (146) umfasst, der außerhalb des Anzeigebereichs ausgebildet ist und den Gate-Außenumfang kreuzt und dazu angeordnet ist, eine gemeinsame Spannung an den Speicherelektrodenleiter (125) anzulegen, und wobei der elektrostatische Stab (146) den gemeinsamen Spannungsleiter (146) umfasst.
- 20 7. Flüssigkristallanzeigevorrichtung (1) gemäß Anspruch 5, wobei die antistatische Diode (170) eine erste antistatische Diode (171) umfasst, welche den Gate-Außenumfang als Steueranschluss (1711) und Eingangsanschluss (1712) und den elektrostatische Stab als Ausgangsanschluss (1713) benutzt, und eine zweite antistatische Diode (172) umfasst, welche den Gate-Außenumfang als Ausgangsanschluss (1723) und den elektrostatischen Stab als Steueranschluss (1721) und Eingangsanschluss (1722) benutzt.
- 25 8. Flüssigkristallanzeigevorrichtung (1) gemäß Anspruch 2, wobei die Flüssigkristallschicht (300) vertikal ausgerichtet ist.
- 30 9. Flüssigkristallanzeigevorrichtung (1) gemäß Anspruch 8, wobei jede Pixelelektrode (161) ein Pixelelektroden-Ausschnittmuster (166) und das zweite Substrat (200) eine gemeinsame Elektrode (251) umfasst, die mit einem gemeinsamen Elektroden-Ausschnittmuster (252) ausgebildet ist.
- 35 10. Flüssigkristallanzeigevorrichtung (1) gemäß Anspruch 9, wobei jede Pixelelektrode (161) eine erste Pixelelektrode (161a) und eine zweite Pixelelektrode (161b) umfasst, die voneinander getrennt sind, und wobei die erste und die zweite Pixelelektrode (161a; 161b) so angeordnet sind, dass sie unterschiedliche Pixelspannungen empfangen.
- 40 11. Flüssigkristallanzeigevorrichtung (1) gemäß Anspruch 10, wobei jeder Dünnschichttransistor (T) eine Drain-Elektrode (143) umfasst, welche eine erste Drain-Elektrode (143a) umfasst, die direkt an die erste Pixelelektrode (161a) eine Datenspannung anlegt, und eine zweite Drain-Elektrode (143b), die gemeinsam mit der zweiten Pixelelektrode (161b) eine Koppelkapazität bildet.
- 45 12. Flüssigkristallanzeigevorrichtung (1) gemäß Anspruch 10, wobei jeder Dünnschichttransistor (T) einen ersten Dünnschichttransistor (TFT1) umfasst, der mit der ersten Pixelelektrode (161a) verbunden ist, und einen zweiten Dünnschichttransistor (TFT2), der mit der zweiten Pixelelektrode (161b) verbunden ist.
- 50 13. Flüssigkristallanzeigevorrichtung (1) gemäß Anspruch 1, wobei ein Gesamtwiderstand jedes elektrischen Vorschaltwiderstands (163) 10% bis 50% eines Gesamtwiderstands des zugehörigen Gate-Hauptleiters (121) ausmacht.
- 55 14. Flüssigkristallanzeigevorrichtung (1) gemäß Anspruch 1, wobei der Widerstandswert jedes elektrischen Vorschaltwiderstands (163) so eingestellt ist, dass die Variation einer Gate-Signalverzögerung infolge des Widerstands des zugehörigen Gate-Hauptleiters (121) im Wesentlichen kleiner ist als die Gate-Signalverzögerung infolge des gesamten Leiterwiderstands.

Revendications

1. Un dispositif d'affichage à cristaux liquides (1) comprenant :

EP 1 892 697 B1

un premier substrat (100) ayant une zone d'affichage entourée d'une zone de non-affichage ;
un deuxième substrat (200) espacé du premier substrat (100) et lui faisant face ;
un anneau d'étanchéité (400) unissant de façon étanche le premier et le deuxième substrats (100, 200) l'un à l'autre dans ladite relation espacée ; et
5 une couche de matériau à cristaux liquides (300) disposée entre le premier substrat (100) le deuxième substrat (200) et l'anneau d'étanchéité (400) ;
le premier substrat (100) comprenant :

des lignes principales de barrière (121) qui sont disposées dans la zone d'affichage ;
10 des tôles de barrière (124 ; 164) qui sont disposées dans la zone de non-affichage à l'extérieur de la zone d'affichage ;

et

chaque ligne principale de barrière (121) étant connectée à une tôle de barrière correspondante (124 ; 164) via une ligne de sortance conductrice (123 ; 144 ; 165) et une résistance ballast électrique respective (163),
15 toutes les deux disposées dans la zone de non-affichage où chaque résistance ballast (163) est formée d'un ou plusieurs matériaux optiquement transmetteurs et électriquement conducteurs ayant un plus grande résistivité électrique que celle du matériau optiquement opaque et électriquement conducteur utilisé pour former les lignes principales de barrière (121) ;

caractérisé en ce que

20 les lignes principales de barrière (121), les tôles de barrière (124 ; 164) et les lignes de sortance (123 ; 144 ; 165) sont formées dans la même couche, et

l'anneau d'étanchéité (400) est formé sur les lignes de sortance (123) et chaque résistance ballast électrique (163) est fournie à l'intérieur d'une zone du premier substrat (100) entourée par l'anneau d'étanchéité (400) en vue en plan.

- 25
2. Le dispositif d'affichage à cristaux liquides (1) selon la revendication 1, où le premier substrat (100) comprend de plus des transistors à fine couche (T) chacun étant électriquement connecté à une ligne principale de barrière respective (121), et des électrodes à pixel (161) chacune étant électriquement connectée à un transistor à fine couche (T) respectif.
30
 3. Le dispositif d'affichage à cristaux liquides (1) selon la revendication 2, où chaque résistance ballast électrique (163) comprend le même matériau que les électrodes à pixel (161).
 4. Le dispositif d'affichage à cristaux liquides (1) selon la revendication 3, où chaque résistance ballast électrique (163) comprend de l'oxyde d'étain et d'indium (ITO) ou oxyde de zinc et d'indium (IZO).
35
 5. Le dispositif d'affichage à cristaux liquides (1) selon la revendication 1, où le premier substrat (100) comprend de plus une barre électrostatique (146) qui traverse la circonférence extérieure de la barrière, la circonférence extérieure de la barrière indiquant le câblage de la barrière connecté aux lignes principales de barrière (121) à l'exception des résistances ballast électriques (163) mais incluant les tôles de barrière (124 ; 164) et les lignes de sortance de barrière (123 ; 144 ; 165) où le premier substrat (100) comprend également une diode antistatique (170) qui est électriquement connectée à la circonférence extérieure de barrière et la barre électrostatique (146).
40
 6. Le dispositif d'affichage à cristaux liquides (1) selon la revendication 5, où le premier substrat (100) comprend également une ligne d'électrode de stockage (125) qui est formée dans la zone d'affichage et s'allonge parallèlement aux lignes principales de barrière (121), et une ligne de tension ordinaire (146) qui est formée à l'extérieur de la zone d'affichage et traverse la circonférence de barrière, et est disposée pour fournir une tension ordinaire à la ligne d'électrode de stockage (125), et la barre électrostatique (146) est disposée pour comprendre la ligne de tension ordinaire (146).
45
 7. Le dispositif d'affichage à cristaux liquides (1) selon la revendication 5, où la diode antistatique (170) comprend une première diode antistatique (171) qui a la circonférence extérieure de barrière comme un terminal de contrôle (1711) et un terminal d'entrée (1712), et la barre électrostatique comme un terminal de sortie (1713) et une deuxième diode antistatique (172) qui a la circonférence extérieure de barrière comme un terminal de sortie (1723), et la barre électrostatique comme un terminal de contrôle (1721) et un terminal d'entrée (1722).
50
 8. Le dispositif d'affichage à cristaux liquides (1) selon la revendication 2, où la couche de cristaux liquides (300) est alignée verticalement.
55

EP 1 892 697 B1

9. Le dispositif d'affichage à cristaux liquides (1) selon la revendication 8, où chaque électrode de pixel (161) comprend un modèle de découpe d'électrode de pixel (166) et le deuxième substrat (200) comprend une électrode commune (251) qui est formée avec un modèle de découpe d'électrode commune (252).
- 5 10. Le dispositif d'affichage à cristaux liquides (1) selon la revendication 9, où chaque électrode de pixel (161) comprend une première électrode de pixel (161a) et une deuxième électrode de pixel (161b) qui sont séparées l'une de l'autre, et la première et la deuxième électrodes de pixel (161a ; 161b) sont disposées pour recevoir différentes tensions de pixel.
- 10 11. Le dispositif d'affichage à cristaux liquides (1) selon la revendication 10, où chaque transistor à fine couche (T) comprend une électrode déversoir (143) qui comprend une première électrode déversoir (143a) fournissant une tension de données directement à la première électrode de pixel (161a) et une deuxième électrode déversoir (143b) formant une capacitance de couplage avec la deuxième électrode de pixel (161b).
- 15 12. Le dispositif d'affichage à cristaux liquides (1) selon la revendication 10, où chaque transistor à fine couche (T) comprend un premier transistor à fine couche (TFT1) qui est connecté à la première électrode de pixel (161a) et un deuxième transistor à fine couche (TFT2) qui est connecté à la deuxième électrode de pixel (161b).
- 20 13. Le dispositif d'affichage à cristaux liquides (1) selon la revendication 1, où une résistance totale de chaque résistance ballast électrique (163) est de 10 à 50% d'une résistance totale de la ligne principale de barrière respective (121).
- 25 14. Le dispositif d'affichage à cristaux liquides (1) selon la revendication 1, où la valeur de résistance de chaque résistance ballast électrique (163) est réglé de sorte que la variation d'un retard de signal de barrière due à la résistance de la ligne principale de barrière respective (121) soit substantiellement inférieure au retard de signal de barrière dû à une résistance de fil totale.

30

35

40

45

50

55

FIG. 1

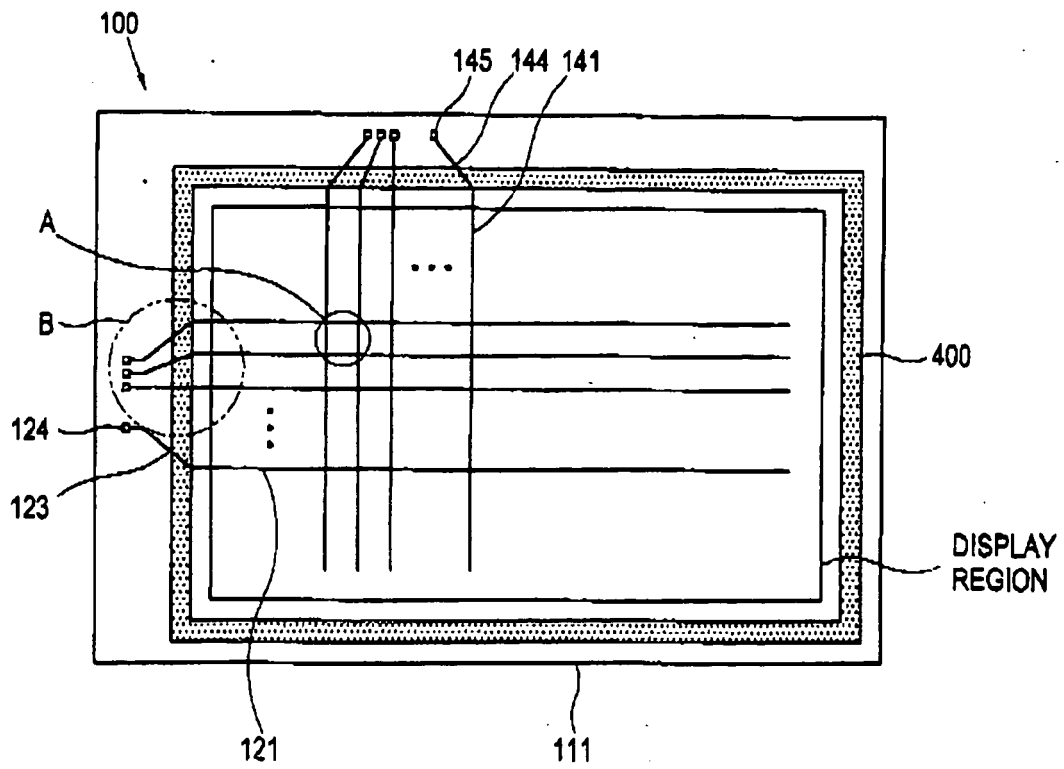

FIG. 3

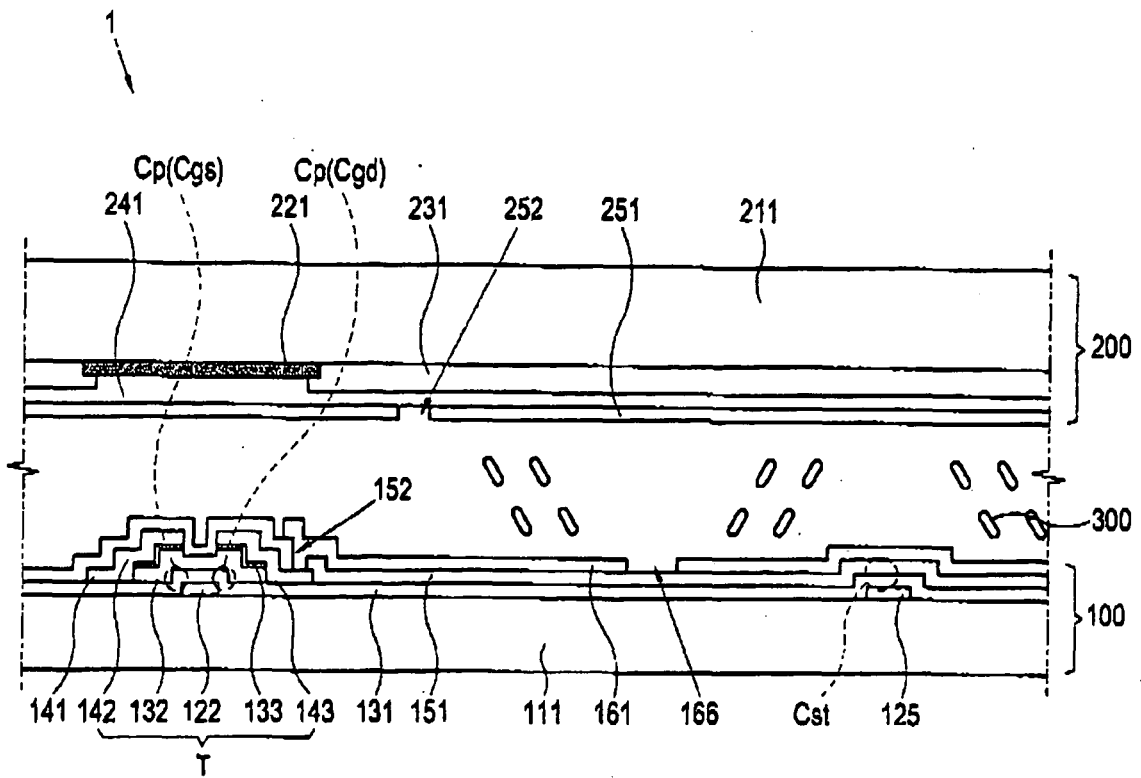

FIG. 4

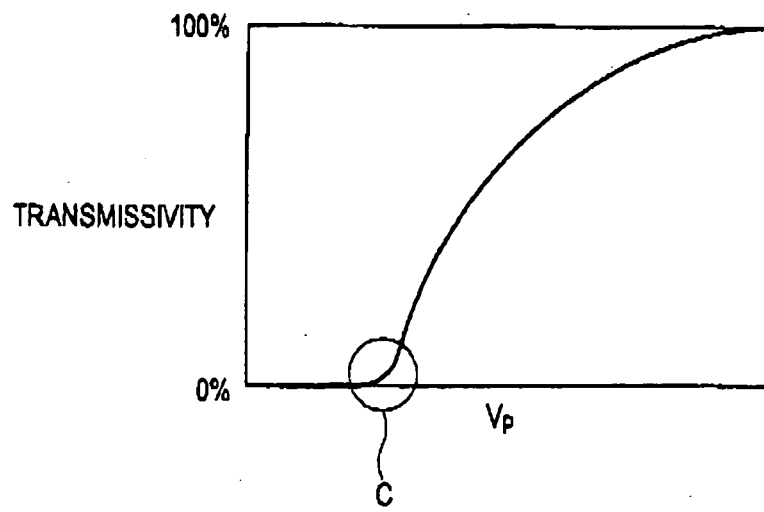

FIG. 5

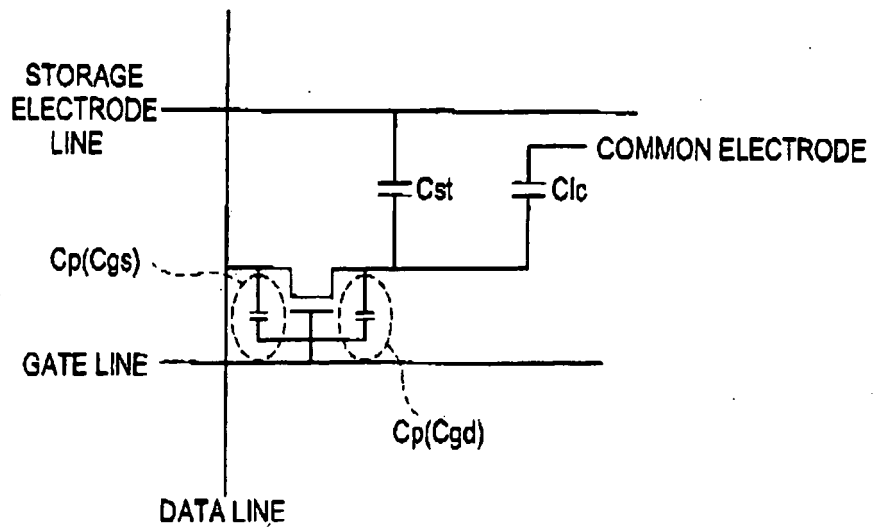

FIG. 6A

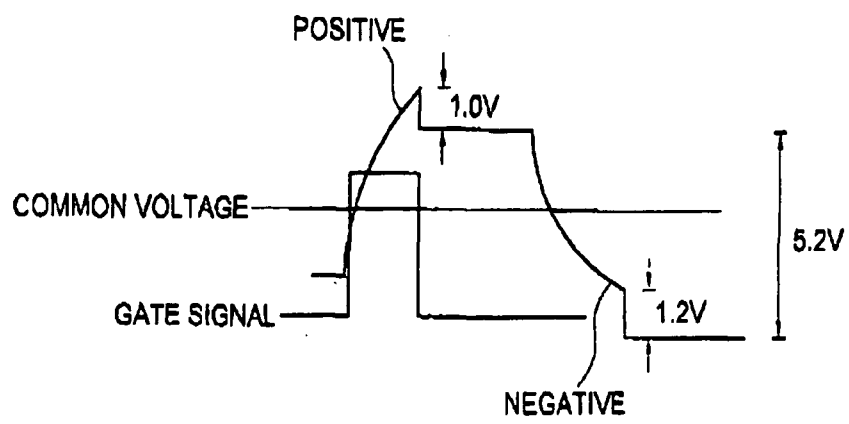

FIG. 6B

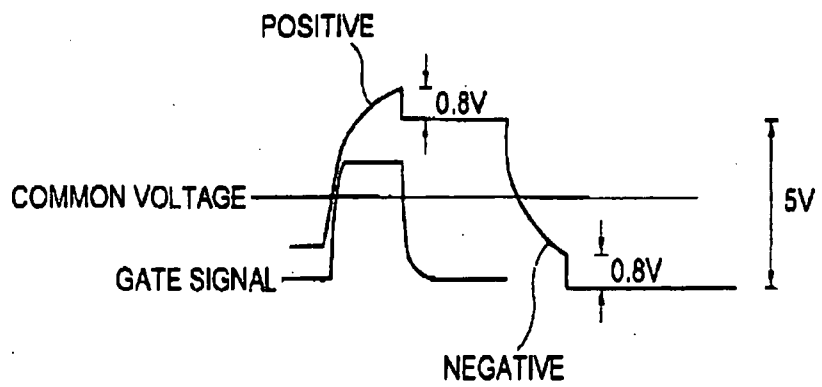

FIG. 7

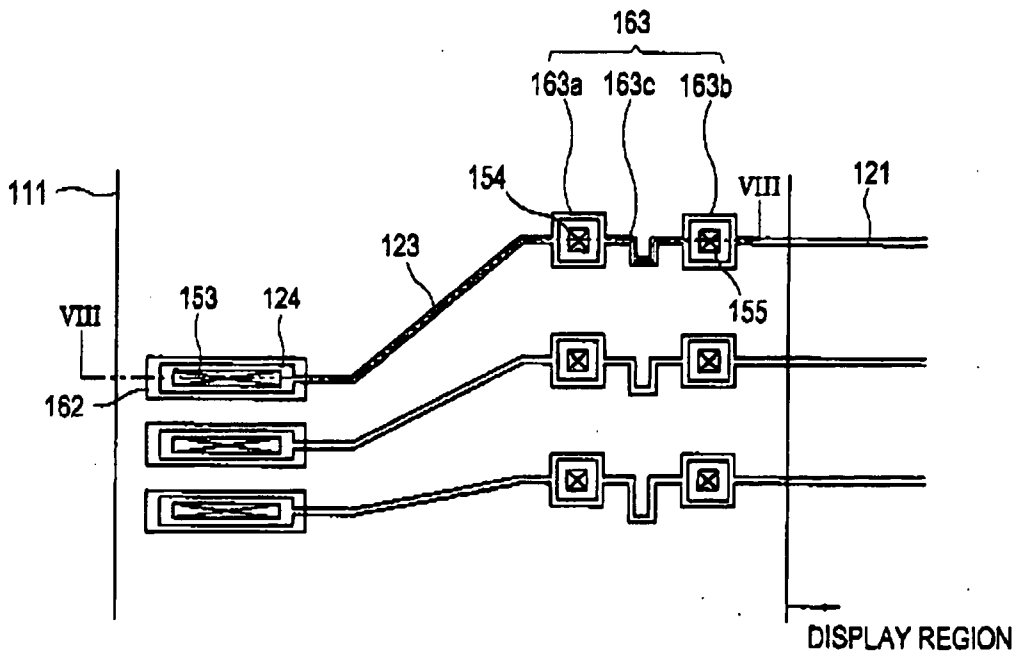

FIG. 8

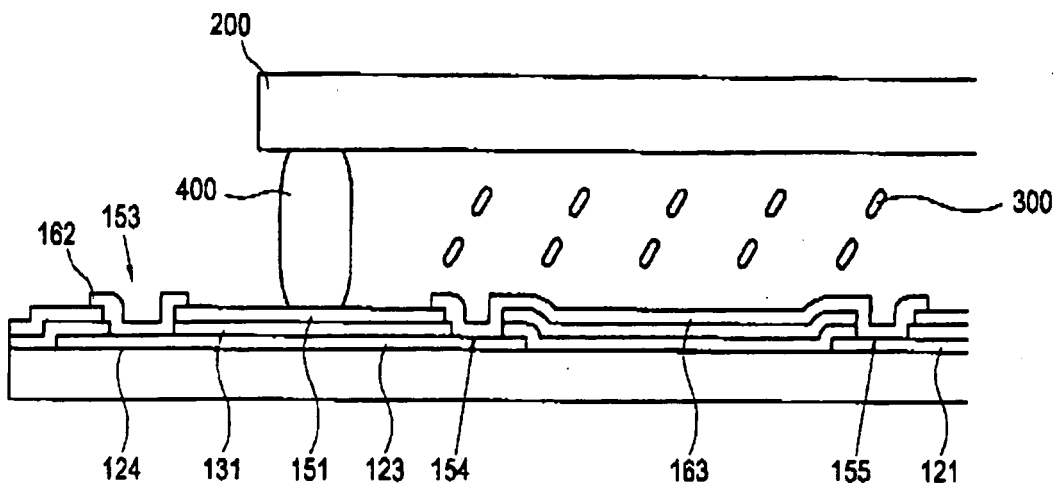

FIG. 9

DELAY VARIATION OF GATE SIGNALS DECREASED,
BRIGHTNESS VARIATION DECREASED

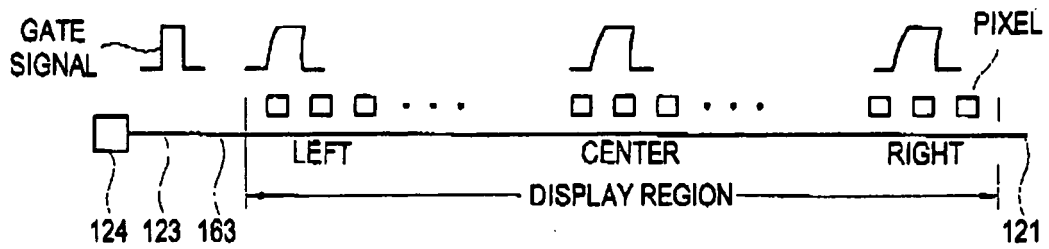

FIG. 10

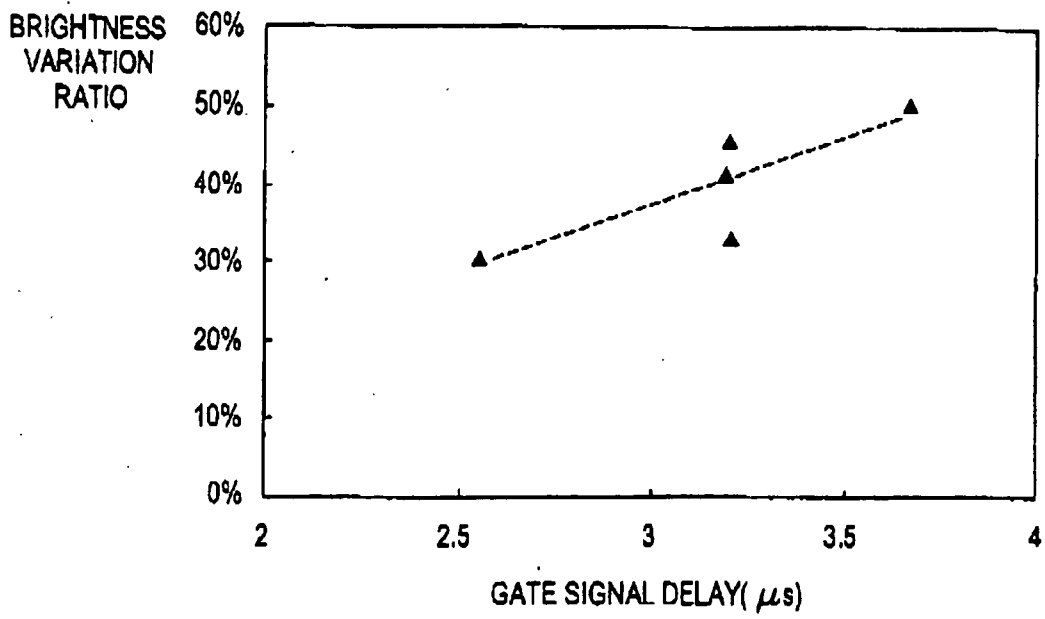

FIG. 11

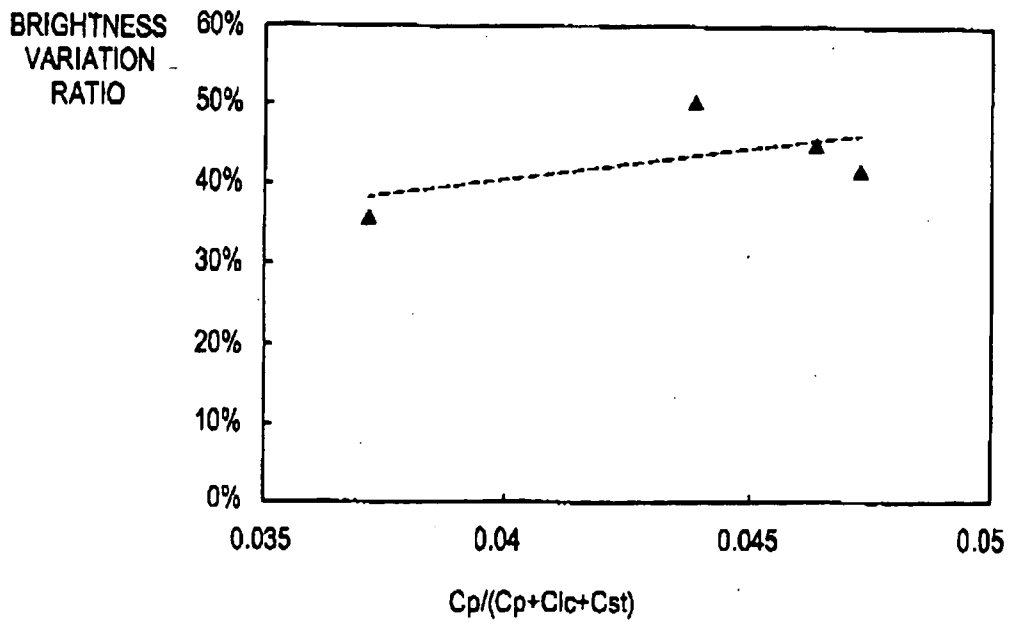

FIG. 12

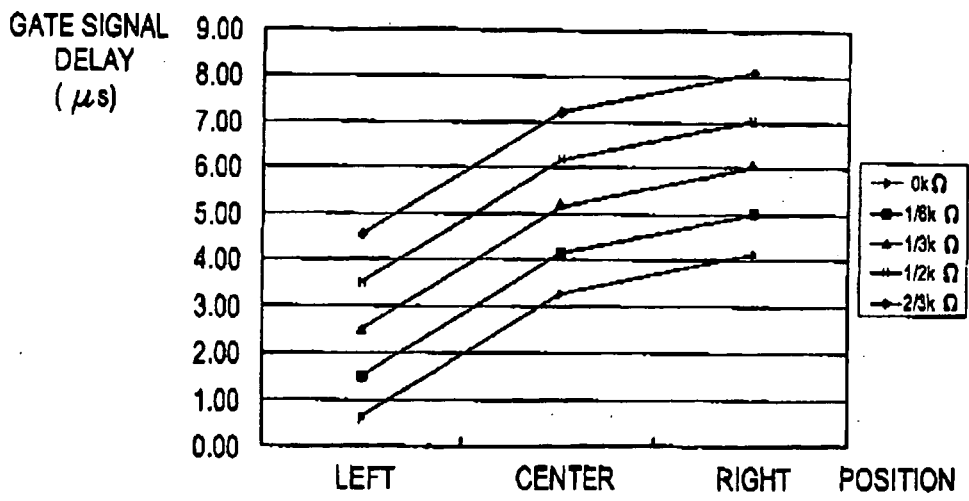

FIG. 13

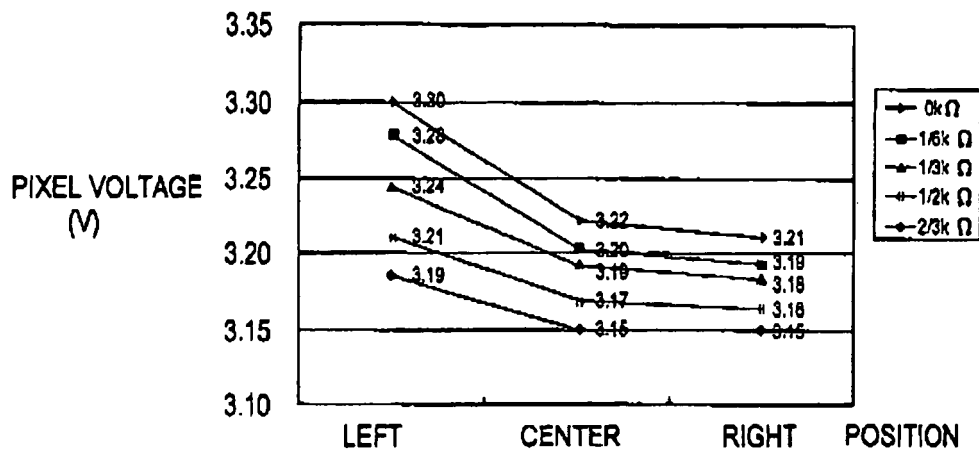

FIG. 14

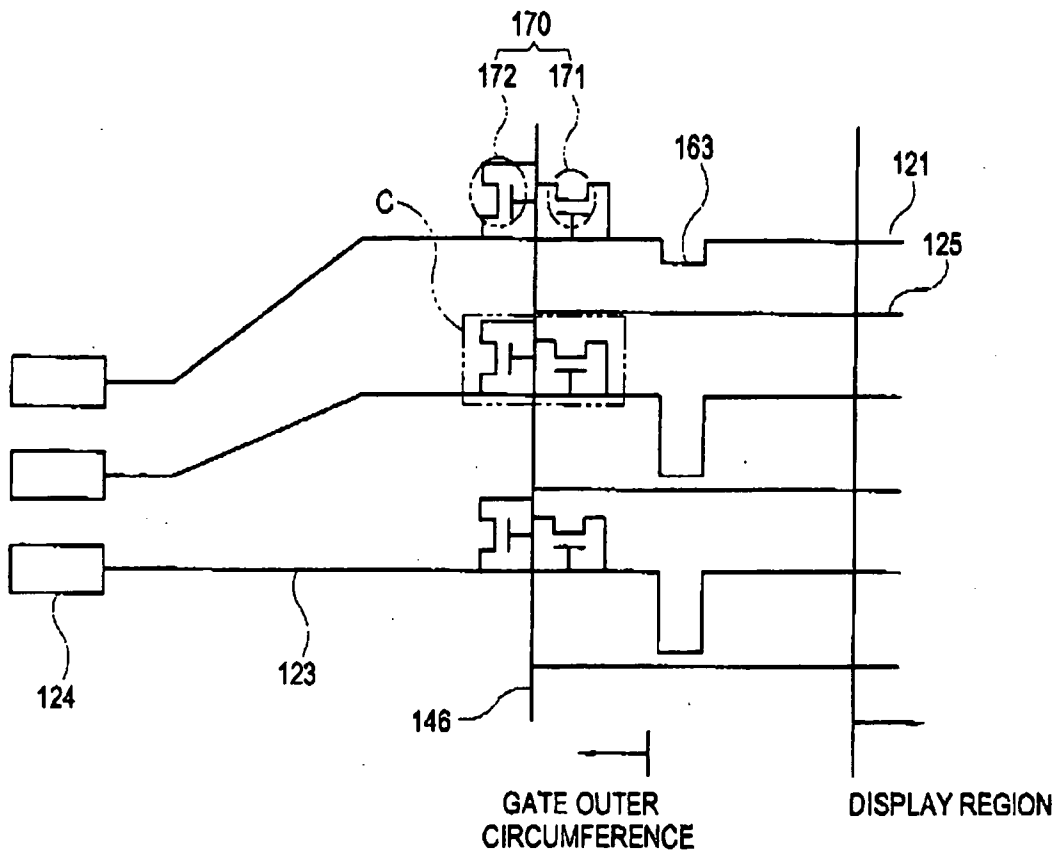

FIG. 15

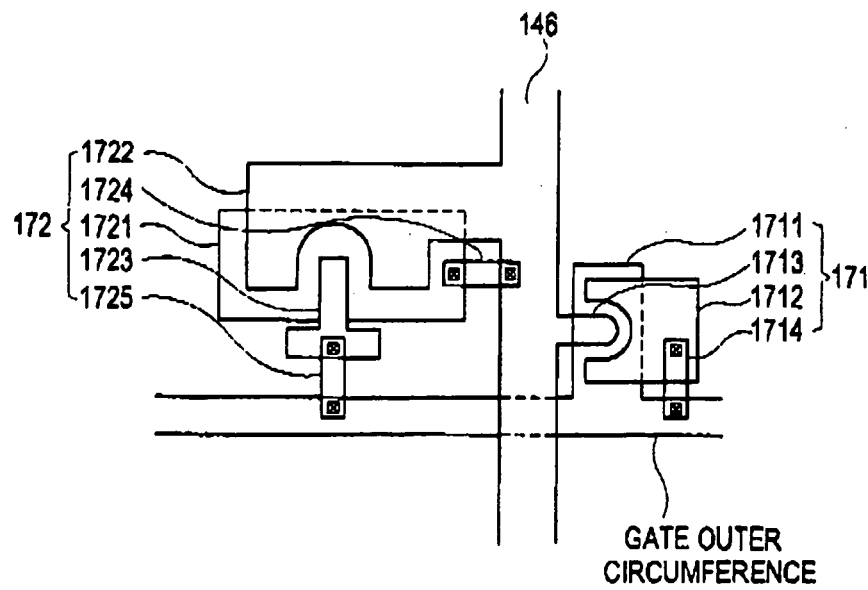

FIG. 16

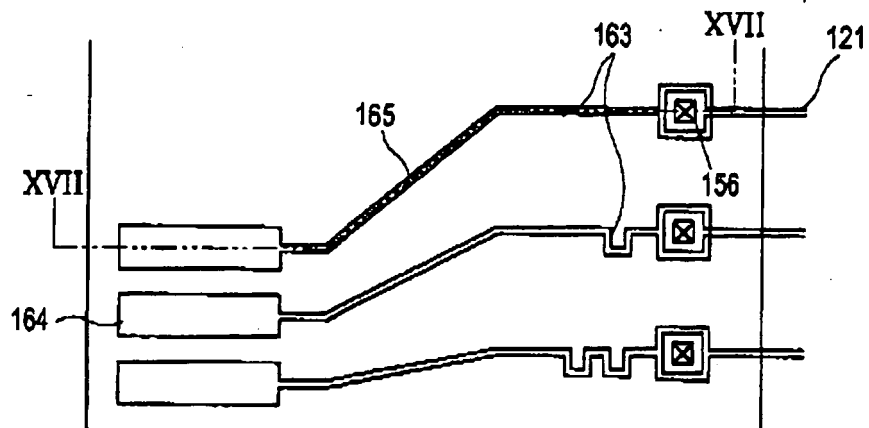

FIG. 17

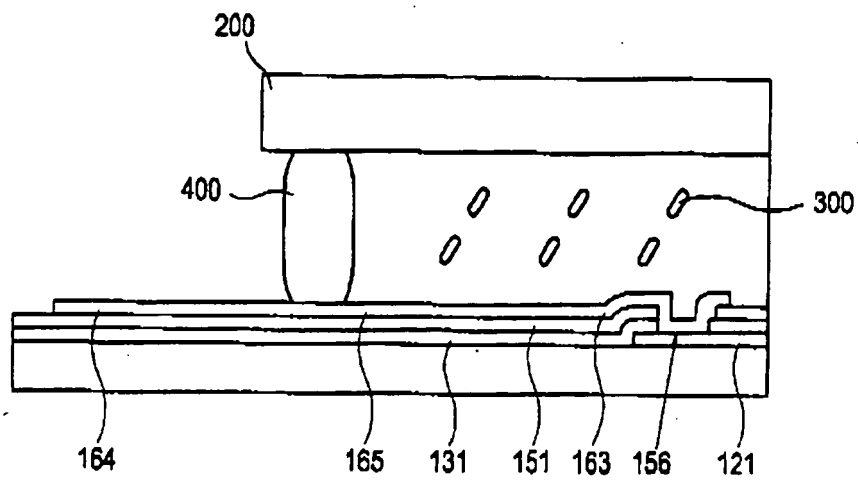

FIG. 18

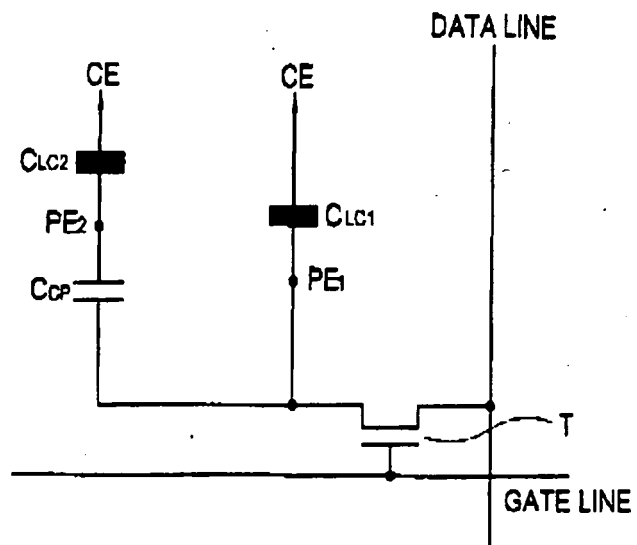

FIG. 19

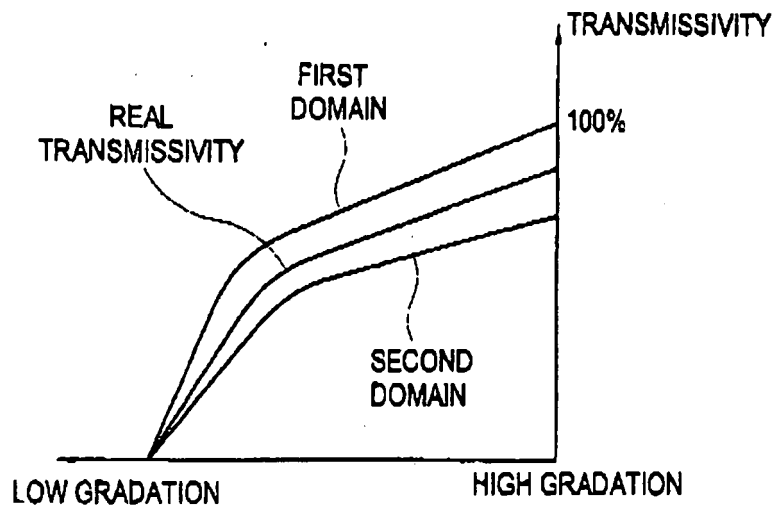

FIG. 20

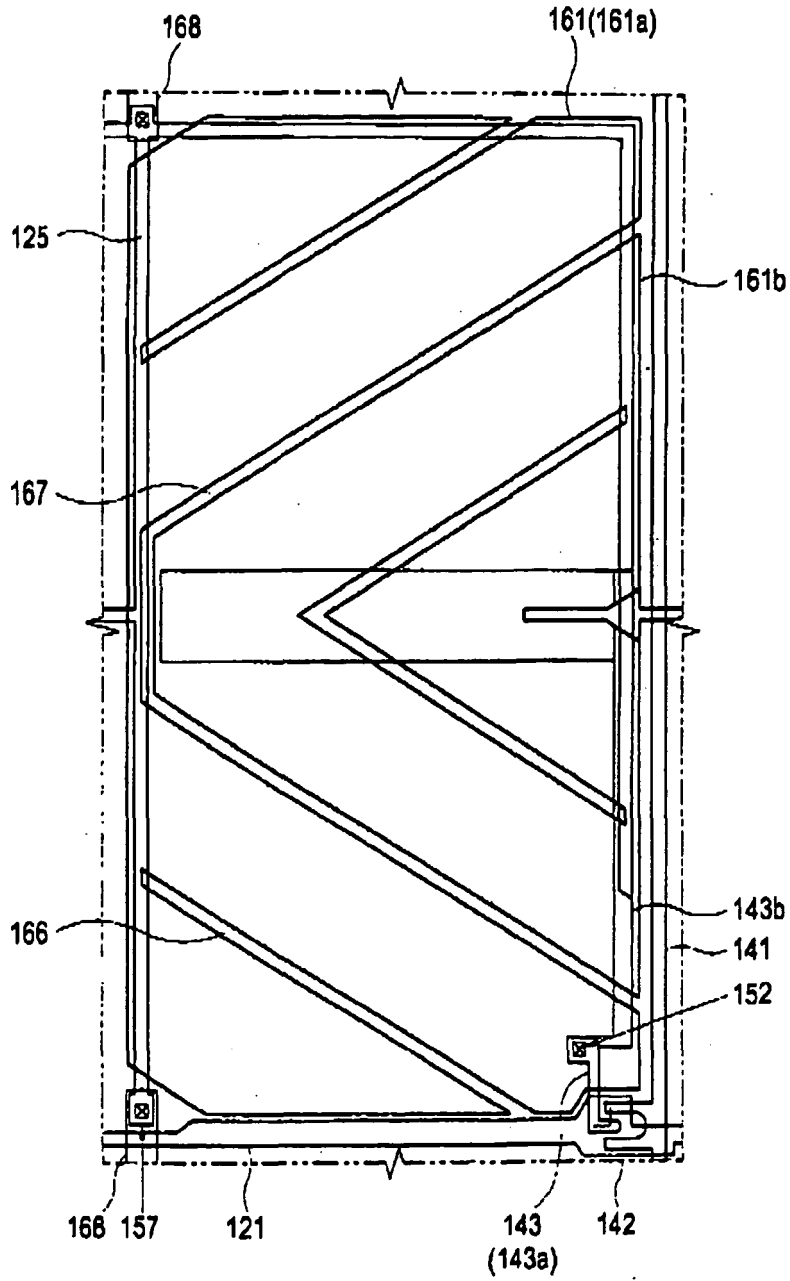
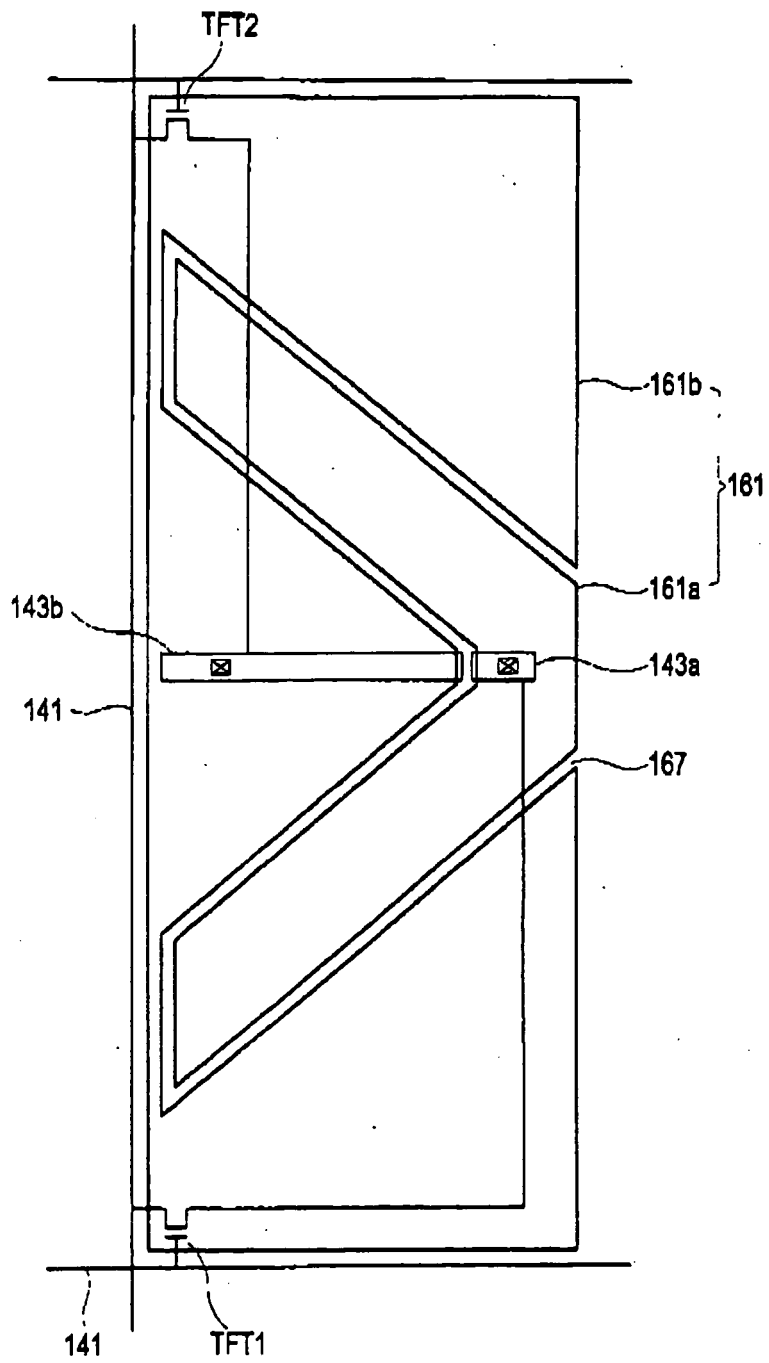

FIG. 21



REFERENCES CITED IN THE DESCRIPTION

This list of references cited by the applicant is for the reader's convenience only. It does not form part of the European patent document. Even though great care has been taken in compiling the references, errors or omissions cannot be excluded and the EPO disclaims all liability in this regard.

Patent documents cited in the description

- JP 04313733 B [0007]
- US 20030227078 A1 [0007]
- US 20060114209 A1 [0007]
- US 20050018121 A1 [0007]
- US 20040135956 A1 [0007]

专利名称(译)	具有延迟补偿的液晶显示装置		
公开(公告)号	EP1892697B1	公开(公告)日	2012-10-10
申请号	EP2007016646	申请日	2007-08-24
[标]申请(专利权)人(译)	三星电子株式会社		
申请(专利权)人(译)	SAMSUNG ELECTRONICS CO. , LTD.		
当前申请(专利权)人(译)	三星DISPLAY CO. , LTD.		
[标]发明人	KIM DONG GYU NA BYOUNG SUN		
发明人	KIM, DONG-GYU NA, BYOUNG-SUN		
IPC分类号	G09G3/36 G02F1/1362 G02F1/139		
CPC分类号	G02F1/136286 G02F1/136204 G02F1/1393 G09G3/3648 G09G2320/0219 G09G2320/0223 G09G2320/0233 G09G2330/04		
代理机构(译)	韦策尔 , WOLFGANG		
优先权	1020070015821 2007-02-15 KR 1020060081056 2006-08-25 KR 1020060124754 2006-12-08 KR		
其他公开文献	EP1892697A1		
外部链接	Espacenet		

摘要(译)

一种液晶显示装置，包括：具有显示区域的第一基板（100）；面向第一基板（100）的第二基板（200）；液晶层（300）设置在第一基板（100）和第二基板（200）之间，第一基板（100）包括：栅极主线（121），设置在显示区域中；栅极焊盘（124），设置在显示区域之外；压电电阻器（163）电连接栅极主线（121）和栅极焊盘（124），并且包括电阻率大于限定栅极主线（121）的主要导电材料的电阻率的材料。

$$V_{kb} = (V_{on} - V_{off}) * C_p / (C_{ic} + C_{ie} + C_p)$$