



(11) **EP 3 217 213 A1**

(12) **EUROPEAN PATENT APPLICATION**
published in accordance with Art. 153(4) EPC

(43) Date of publication:
13.09.2017 Bulletin 2017/37

(51) Int Cl.:
G02F 1/1335^(2006.01) G02F 1/1343^(2006.01)

(21) Application number: **15790436.8**

(86) International application number:
PCT/CN2015/074455

(22) Date of filing: **18.03.2015**

(87) International publication number:
WO 2016/070542 (12.05.2016 Gazette 2016/19)

(84) Designated Contracting States:
AL AT BE BG CH CY CZ DE DK EE ES FI FR GB GR HR HU IE IS IT LI LT LU LV MC MK MT NL NO PL PT RO RS SE SI SK SM TR
Designated Extension States:
BA ME
Designated Validation States:
MA

(71) Applicant: **BOE Technology Group Co., Ltd.**
Chaoyang District,
Beijing 100016 (CN)

(72) Inventor: **LI, Wenbo**
Beijing 100176 (CN)

(74) Representative: **Brötz, Helmut et al**
Rieder & Partner mbB
Patentanwälte - Rechtsanwalt
Corneliusstrasse 45
42329 Wuppertal (DE)

(30) Priority: **07.11.2014 CN 201410642435**

(54) **ARRAY SUBSTRATE, LIQUID CRYSTAL DISPLAY PANEL AND DISPLAY DEVICE**

(57) An array substrate, a liquid crystal display panel and a display device are provided. The array substrate comprises: a base substrate (001), a data line (002) and a gate line (003) intersecting with each other on the base substrate (001), a plurality of pixel regions defined by the data line (002) and the gate line (003) on the array substrate and arranged in array, and a wire grid polarizing film (004) arranged in respective pixel regions and con-

figured for changing natural light passing therethrough into linearly polarized light; wherein, the wire grid polarizing film (004) in the respective pixel regions has a grating structure, so the wire grid polarizing film plays a role of polarizer, and therefore, a process of separately attaching a polarizer after cell-assembling is omitted, which can improve production efficiency, save production cost, and be conducive to thinning the display panel.

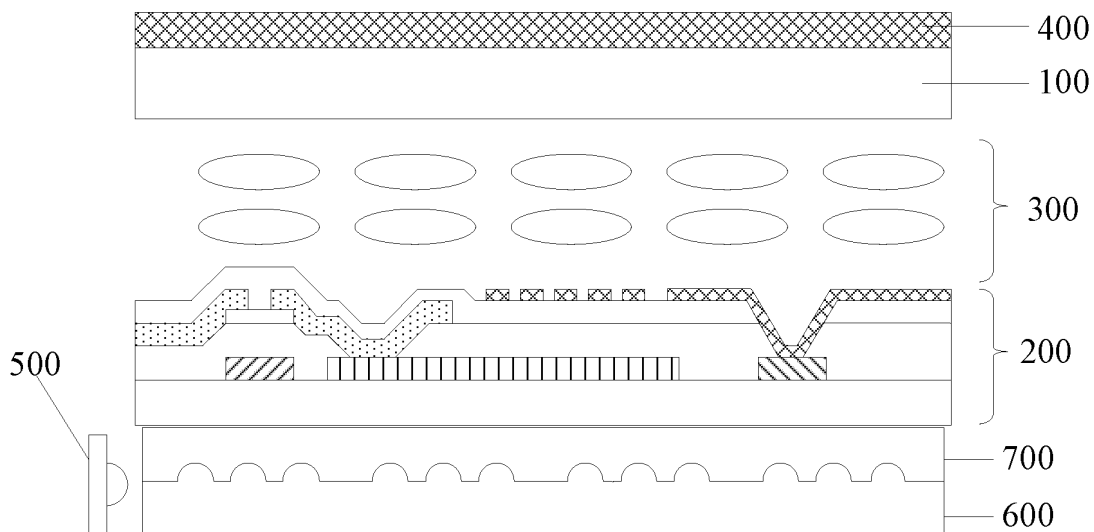

FIG. 5

EP 3 217 213 A1

Description

TECHNICAL FIELD

[0001] Embodiments of the present disclosure relate to an array substrate, a liquid crystal display panel and a display device.

BACKGROUND

[0002] A liquid crystal display panel mainly consists of an array substrate, an opposed substrate and liquid crystal molecules located between the array substrate and the opposed substrate. In a production process, after respective film layers on the array substrate and the opposed substrate are fabricated, the array substrate and the opposed substrate are cell-assembled, and then polarizers are attached to upper and lower surfaces of the liquid crystal display panel, respectively, and finally a backlight module is further arranged on a side of the array substrate of the liquid crystal display panel, to form a display panel.

[0003] It can be seen that, the above production process of forming a liquid crystal display panel is relatively complicated, and it is necessary to paste polarizers after cell-assembling, which is not conducive to improving production efficiency. In addition, it is necessary to provide film attaching machines for attaching polarizers respectively, which will also increase production cost. Finally, the polarizers attached to outer side of the display panel have certain thickness, which will limit overall thickness of the resulted liquid crystal display panel, so thus disadvantageous for development of lighter and thinner devices.

SUMMARY

[0004] Embodiments of the present disclosure relate to an array substrate, a liquid crystal display panel and a display device, so as to thin a display panel, reduce production cost and simplify production process.

[0005] At least one embodiment of the present disclosure provides an array substrate, comprising: a base substrate; a data line and a gate line intersecting with each other on the base substrate, a plurality of pixel regions defined by the data line and the gate line on the array substrate and arranged in array, and a wire grid polarizing film arranged in respective pixel regions and configured for changing natural light passing therethrough into linearly polarized light; wherein, the wire grid polarizing film in the respective pixel regions has a grating structure.

[0006] For example, the grating structure consists of metal wires arranged linearly.

[0007] For example, the grating structure has a grating pitch less than half of a minimum wavelength of visible light.

[0008] For example, the grating pitch is 60nm-100nm.

[0009] For example, the wire grid polarizing film and

the data line or the gate line are arranged on a same layer and insulated from each other.

[0010] For example, in the respective pixel regions, the wire grid polarizing film functions as a pixel electrode and is electrically connected with a drain electrode of a thin film transistor located on an intersection of the data line and the gate line.

[0011] For example, in the respective pixel regions, the wire grid polarizing film functions as a pixel electrode and a common electrode of an interdigital structure, the wire grid polarizing film functioning as the pixel electrode is electrically connected with a drain electrode of a thin film transistor located on an intersection of the data line and the gate line.

[0012] For example, the drain electrode and the data line are arranged on a same layer.

[0013] For example, the wire grid polarizing film functioning as the pixel electrode is arranged on a same layer as the data line, or the wire grid polarizing film functioning as the pixel electrode and the common electrode of the interdigital structure is arranged on a same layer as the data line.

[0014] For example, the common electrode is arranged above a film layer of the data line.

[0015] For example, in the respective pixel regions, a transparent conductive metal oxide layer is arranged on the wire grid polarizing film.

[0016] For example, in the respective pixel regions, the transparent conductive metal oxide layer and the wire grid polarizing film are consistent in pattern.

[0017] For example, the wire grid polarizing film and the gate line are arranged on a same layer, the wire grid polarizing film functions as a common electrode in the respective pixel regions.

[0018] For example, a pixel electrode is further arranged in the respective pixel regions; the wire grid polarizing film is electrically connected with the pixel electrode in the respective pixel regions.

[0019] For example, the array substrate further comprising a common electrode line arranged on a same layer as the gate line and extended in a same direction as the gate line; wherein, the wire grid polarizing film is electrically connected with the common electrode line in the respective pixel regions.

[0020] An embodiment of the present disclosure further provides a liquid crystal display panel, comprising: an array substrate and an opposed substrate arranged oppositely, and a liquid crystal layer filled between the array substrate and the opposed substrate; wherein, the array substrate is the array substrate provided by the embodiments of the present disclosure.

[0021] For example, an upper polarizer is arranged on a side of the opposed substrate away from the array substrate; for example, an extending direction of the grating structure of the wire grid polarizing film and a transmission axis direction of the upper polarizer are parallel to each other.

[0022] An embodiment of the present disclosure fur-

ther provides a display device, comprising any liquid crystal display panel provided by the embodiments of the present disclosure.

BRIEF DESCRIPTION OF THE DRAWINGS

[0023] In order to clearly illustrate the technical solution of the embodiments of the disclosure, the drawings of the embodiments will be briefly described in the following; it is obvious that the described drawings are only related to some embodiments of the disclosure and thus are not limitative of the disclosure.

FIG. 1 is a top view of an array substrate provided by an embodiment of the disclosure;

FIG. 2a to FIG. 2d are structural schematic diagrams of Embodiment I, respectively;

FIG. 3a and FIG. 3b are structural schematic diagrams of Embodiment II, respectively;

FIG. 4 is a structural schematic diagram of Embodiment III;

FIG. 5 is a structural schematic diagram of a liquid crystal panel provided by an embodiment of the disclosure.

DETAILED DESCRIPTION

[0024] In order to make objects, technical details and advantages of the embodiments of the disclosure apparent, the technical solutions of the embodiment will be described in a clearly and fully understandable way in connection with the drawings related to the embodiments of the disclosure. It is obvious that the described embodiments are just a part but not all of the embodiments of the disclosure. Based on the described embodiments herein, those skilled in the art can obtain other embodiment(s), without any inventive work, which should be within the scope of the disclosure.

[0025] The embodying modes for an array substrate, a liquid crystal display panel and a display device provided by the embodiments of the present disclosure are described in detail hereinafter in conjunction with the accompanying drawings.

[0026] Sizes and shapes of respective film layers and regions in the accompanying drawings do not reflect true proportions of the array substrate, but are only intended to illustrate content of the embodiments of the present disclosure.

[0027] FIG. 1 is a top view of an array substrate provided by an embodiment of the disclosure, and the array substrate comprises a base substrate 001 and a data line 002 and a gate line 003 intersecting with each other on the base substrate 001; on the array substrate, a plurality of pixel regions arranged in array are defined by the data line 002 and the gate line 003. FIG. 1 only shows respective parts in one pixel region; and in the respective pixel regions, a wire grid polarizing film 004 is further arranged for changing natural light pass therethrough to

linearly polarized light.

[0028] The wire grid polarizing film 004 in the respective pixel regions has a grating structure.

[0029] For example, the wire grid polarizing film 004 usually adopts a grating structure consisting of metal wires arranged linearly; along an extending direction of the metal wires, free electrons can be driven by an electric field to consume electric energy, while an electric field perpendicular to the metal wires will not be absorbed. Therefore, light components perpendicular to the direction of the metal wires are transmitted, while the light components parallel to the metal wires are absorbed, and finally natural light becomes linearly polarized light after passing through the wire grid polarizing film 004. Thus, a wire grid polarizing film fabricated in respective pixel regions in an array substrate, instead of a polarizer attached on an outer side of the array substrate, can be used for changing natural light pass therethrough into linearly polarized light. When ensuring normal display of the liquid crystal display panel, the embodiment of the present disclosure can form a wire grid polarizing film which plays a role of polarizer in a fabrication process of an array substrate, and therefore, a separate process of attaching a polarizer after cell-assembling is omitted, which can improve production efficiency, save production cost, and be conducive to thinning the display panel.

[0030] In general, a wavelength of visible light is between 400nm-800nm; in order to ensure that the wire grid polarizing film 004 can polarizing natural light, a grating pitch a in a grating structure should be less than half of a minimum wavelength of visible light. For example, the grating pitch a of the wire grid polarizing film 004 is set to be less than 200nm. For example, in order to make the wire grid polarizing film 004 better change natural light pass therethrough into linearly polarized light, the grating pitch a may be set between 60nm -100nm.

[0031] For example, the grating structure of the wire grid polarizing film 004 in the array substrate provided by the embodiment of the present disclosure can be formed by processes of coating a photoresist, exposing and developing, etching and so on. For example, exposure and development can be completed by a laser interference exposure method. That is, laser with a specific wavelength is used for irradiating photoresist from two directions of angle θ to form interference fringes for exposing. A concave-convex grid structure with various intervals in the wavelength range of the used laser can be obtained by changing θ , i.e., a grating structure is formed. Of course, the grating structure of the wire grid polarizing film 004 can also be formed by nanoimprint, which is not described in detail here.

[0032] For example, since in the array substrate provided by the embodiment of the present disclosure, the wire grid polarizing film 004 serving as a polarizer is usually made of metal material, and, the wire grid polarizing film 004 arranged in respective pixel regions often overlaps with effective display regions of the respective pixel regions. Therefore, the wire grid polarizing film 004 does

not overlap with the data line 002 or the gate line 003. In actual operation, the wire grid polarizing film 004 may be set to be arranged on a same layer as the data line 002 or the gate line 003 and insulated from each other, so the wire grid polarizing film 004 can be fabricated without adding an additional patterning process to the original fabrication process of the array substrate, to save production cost and improve production efficiency.

[0033] On this basis, the wire grid polarizing film 004 in the array substrate provided by the embodiment of the present disclosure can be further function as a pixel electrode, a common electrode or a storage capacitor besides a polarizer. The multiplex function of the wire grid polarizing film 004 is described by a few specific embodiments hereinafter.

Embodiment I

[0034] In an array substrate of the embodiment, as shown in FIG. 2a and FIG. 2b, a pixel electrode are the same as a wire grid polarizing film. For example, the wire grid polarizing film 004 in the respective pixel regions also functions as the pixel electrode, which is electrically connected with a drain electrode 005 of a thin film transistor located on an intersection of the gate line 003 and the data line 002, and the drain electrode 005 is usually arranged on the same layer as the data line 002.

[0035] For example, in the case that the wire grid polarizing film 004 is arranged on the same layer as the data line 002, as shown in FIG. 2a, because the wire grid polarizing film 004 serving as a pixel electrode is fabricated on the same layer as the drain electrode 005 of the thin film transistor, the wire grid polarizing film 004 and the drain electrode 005 can be directly electrically connected. In the case that the wire grid polarizing film 004 is arranged on the same layer as the gate line 003, as shown in FIG. 2b, because the wire grid polarizing film 004 serving as a pixel electrode is fabricated on the same layer as the gate electrode 006 of the thin film transistor which is not on the same layer as the drain electrode 005, the wire grid polarizing film 004 and the drain electrode 005 can be electrically connected through a via hole.

[0036] For example, during the fabrication of the array substrates with the structures shown in FIG. 2a and FIG. 2b, the wire grid polarizing film 004 serving as the pixel electrode is formed along with the formation of the data line 002 or the gate line 003, which can omit a separate pixel electrode commonly formed on the drain electrode. Thus, the numbers of used masks and the fabrication processes can be reduced.

[0037] Further, in the embodiment of FIG. 2a and FIG. 2b, ADS mode array substrate is taken as an example. Thus, a common electrode 007 is further arranged above a film layer of the data line 002, and the common electrode 007 is connected with a common electrode line 008 through a via hole, and the common electrode line 008 is usually arranged on the same layer as the gate line

003. If the wire grid polarizing film 004 is made of easily oxidized metal such as Al, the common electrode 007 arranged above can prevent the wire grid polarizing film 004 from being oxidized. Thus, it is not necessary to separately arrange a protective layer to protect the wire grid polarizing film 004 in the ADS mode array substrate. However, in TN mode array substrate, if the wire grid polarizing film serving as a pixel electrode and the data line are arranged on the same layer, no common electrode protects the wire grid polarizing film 004 which is easily oxidized. Therefore, in order to better prevent the fabricated wire grid polarizing film 004 from being oxidized, for example, in respective pixel regions, as shown in FIG. 2c, a transparent conductive metal oxide layer 009, e.g., an ITO film layer, is arranged on the wire grid polarizing film 004. Further, since the transparent conductive metal oxide layers 009 arranged on the wire grid polarizing films 004 in different pixel regions need to be separated from each other, it is inevitable to pattern the added transparent conductive metal oxide layer 009, which will add a production process for the array substrate. In order to avoid the additional production process for the array substrate, for example, in the respective pixel regions, the transparent conductive metal oxide layer 009 and the wire grid polarizing film 004 are set to be consistent in pattern, as shown in FIG. 2d. In this way, by one patterning process, the patterns of the transparent conductive metal oxide layer 009 and the wire grid polarizing film 004 can be formed at the same time, without increasing the number of used masks.

Embodiment II

[0038] In an IPS mode array substrate of the embodiment, as shown in FIG. 3a and FIG. 3b, a pixel electrode and a common electrode are the same as a wire grid polarizing film. For example, in each pixel unit of the IPS mode array substrate, a pixel electrode and a common electrode are interdigitated and arranged on the same layer. Therefore, in the respective pixel regions, the wire grid polarizing film 004 also functions as the pixel electrode and the common electrode of interdigital structure; the wire grid polarizing film 004 functioning as the pixel electrode is electrically connected with a drain electrode 005 of a thin film transistor located on an intersection of the data line 002 and the gate line 003, and the drain electrode 005 and the data line 002 are arranged on the same layer.

[0039] For example, in the case that the wire grid polarizing film 004 is arranged on the same layer as the data line 002, as shown in FIG. 3a, because the wire grid polarizing film 004 serving as the pixel electrode and the common electrode is fabricated on the same layer as the drain electrode 005 of the thin film transistor, part a of the wire grid polarizing film 004 serving as the pixel electrode can be directly electrically connected with the drain electrode 005, and part b of the wire grid polarizing film 004 serving as the common electrode can be connected

with a common electrode line 008 through a via hole, and the common electrode line 008 is arranged on the same layer as the gate line 003 and the gate electrode 006. In the case that the wire grid polarizing film 004 is arranged on the same layer as the gate line 003, as shown in FIG. 3b, because the wire grid polarizing film 004 serving as the pixel electrode and the common electrode is fabricated on the same layer as the gate electrode 006 of the thin film transistor, part a of the wire grid polarizing film 004 serving as the pixel electrode is electrically connected with the drain electrode 005 through a via hole, and part b of the wire grid polarizing film 004 serving as the common electrode is directly connected with the common electrode line 008, and the common electrode line 008 is arranged on the same layer as the gate line 003 and the gate electrode 006.

[0040] For example, during fabrication of the IPS mode array substrate as shown in FIG. 3a and FIG. 3b, the wire grid polarizing film 004 serving as the pixel electrode and the common electrode is formed along with the formation of the data line 002 or the gate line 003, which can omit a pixel electrode and a common electrode separately formed on the drain electrode. Thus, the numbers of used masks and the fabrication processes can be reduced.

[0041] Further, in the case that the wire grid polarizing film 004 serving as the pixel electrode and the common electrode is arranged on the same layer as the data line 002, no protection is provided above the wire grid polarizing film 004 which is easily oxidized. Therefore, in order to better prevent the fabricated wire grid polarizing film 004 from being oxidized, for example, a conductive oxide layer may also be added in the same manner used in Embodiment I. That is, in respective pixel regions, a transparent conductive metal oxide layer, e.g., an ITO film layer, is arranged on the wire grid polarizing film 004. Similarly, in order to avoid an additional production process for the array substrate, for example, in the respective pixel regions, the transparent conductive metal oxide layer and the wire grid polarizing film 004 are set to be consistent in pattern.

Embodiment III

[0042] In an array substrate of the embodiment, as shown in FIG. 4, a common electrode and a wire grid polarizing film are the same. For example, the wire grid polarizing film 004 and the gate line 003 are arranged on a same layer, and the wire grid polarizing film 004 also functions as a common electrode in the respective pixel regions.

[0043] For example, during the fabrication of the ADS mode array substrate as shown in FIG. 4, the wire grid polarizing film 004 serving as the common electrode is formed along with the formation of the gate line 003 and the gate electrode 006, which can omit a common electrode separately formed on the drain electrode. Thus, the numbers of used masks and the fabrication processes can be reduced.

Embodiment IV

[0044] In the embodiment, a wire grid polarizing film can be connected with a pixel electrode, or can be connected with a common electrode line as a part of a storage capacitor.

[0045] For example, in the case that pixel electrodes is separately arranged in respective pixel regions, the wire grid polarizing films 004 can be electrically connected with the pixel electrodes in the respective pixel regions, to form a part of a storage capacitor, so as to increase storage capacitance and improve display resolution; alternatively, in the case that a common electrode line and a gate line are arranged on a same layer and extended in a same direction in an array substrate, the wire grid polarizing films 004 can be electrically connected with the common electrode lines in the respective pixel regions, to form a part of a storage capacitor, so as to increase storage capacitance and improve display resolution.

[0046] The embodiment of the disclosure further provides a liquid crystal display panel, as shown in FIG. 5, comprising an opposed substrate 100 and an array substrate 200 opposite to each other, and a liquid crystal layer 300 filled in between the array substrate 200 and the opposed substrate 100.

[0047] The array substrate 200 is any array substrate provided by the embodiment of the present disclosure.

[0048] For example, the opposed substrate 100 is a color filter substrate, including a color filter unit corresponding to a pixel region on the array substrate 200, and further including a black matrix and so on.

[0049] For example, an upper polarizer 400 is arranged on a side of the opposed substrate 100 away from the array substrate 200.

[0050] For example, an extending direction of a grating structure of a wire grid polarizing film 004 in the array substrate 200 and a transmission axis direction of the upper polarizer 400 are parallel to each other. That is, in the array substrate 200, linearly polarized light passing through the wire grid polarizing film 004 and the linearly polarized light passing through the upper polarizer 400 are perpendicular to each other in polarization direction.

[0051] In addition, in the liquid crystal display panel provided by the embodiment of the present disclosure, as shown in FIG. 5, further comprising a backlight module arranged on an outer side of the array substrate. The backlight module includes a LED lamp component 500, a reflecting plate 600 and a light guiding plate 700. Of course, The backlight module can also include other components, which is not defined here.

[0052] The embodiment of the present disclosure further provides a display device, comprising any one of the liquid crystal display panels provided by the embodiments of the present disclosure. The display device can be any product or part having a display function, such as mobile phone, a watch, a tablet computer, a television, a monitor, a laptop, a digital photo frame and a navigator.

For implementation of the display device, the embodiments of the above-described liquid crystal display panel can be referred to, and repeated parts will not be illustrated here.

[0053] The array substrate, the liquid crystal display panel and the display device provided by the embodiments of the present disclosure, the wire grid polarizing film in respective pixel regions of the array substrate is adopted to replace a polarizer attached on an outer side of the array substrate. The grating structure has a grating pitch less than half of the minimum wavelength of visible light is used in the wire grid polarizing films in respective pixel regions, to changing natural light passing there-through into linearly polarized light. In the embodiments of the present disclosure, the wire grid polarizing film which plays a role of polarizer can be formed during the fabrication of the array substrate, without affecting normal display of the liquid crystal display panel. Therefore, a process of separately attaching a polarizer after cell-assembly is omitted, which can improve production efficiency, save production cost, and be conducive to thinning the display panel.

[0054] The foregoing embodiments merely are exemplary embodiments of the disclosure, and not intended to define the scope of the disclosure; modification or substitution which is easily thought by any person skilled in the art within the technical scope disclosed by the disclosure should fall into the protection scope of the disclosure. Therefore, the protection scope of the disclosure should be subject to the protection scope of the claims.

[0055] The present application claims priority of Chinese Patent Application No. 201410642435.6 filed on November 7, 2014, the disclosure of which is incorporated herein by reference in its entirety as part of the present application.

Claims

1. An array substrate, comprising:
 - a base substrate;
 - a data line and a gate line intersecting with each other on the base substrate, a plurality of pixel regions defined by the data line and the gate line on the array substrate and arranged in array, and
 - a wire grid polarizing film arranged in respective pixel regions and configured for changing natural light passing therethrough into linearly polarized light; wherein, the wire grid polarizing film in the respective pixel regions has a grating structure.
2. The array substrate according to claim 1, wherein, the grating structure consists of metal wires arranged linearly.
3. The array substrate according to claim 1 or 2, wherein, the grating structure has a grating pitch less than half of a minimum wavelength of visible light.
4. The array substrate according to any one of claims 1 to 3, wherein, the grating pitch is 60nm-100nm.
5. The array substrate according to any one of claims 1 to 4, wherein the wire grid polarizing film and the data line or the gate line are arranged on a same layer and insulated from each other.
6. The array substrate according to any one of claims 1 to 5, wherein, in the respective pixel regions, the wire grid polarizing film functions as a pixel electrode and is electrically connected with a drain electrode of a thin film transistor located on an intersection of the data line and the gate line; or, in the respective pixel regions, the wire grid polarizing film functions as a pixel electrode and a common electrode of an interdigital structure, the wire grid polarizing film functioning as the pixel electrode is electrically connected with a drain electrode of a thin film transistor located on an intersection of the data line and the gate line.
7. The array substrate according to claim 6, wherein, the drain electrode and the data line are arranged on a same layer.
8. The array substrate according to claim 6 or 7, wherein, the wire grid polarizing film functioning as the pixel electrode is arranged on a same layer as the data line, or the wire grid polarizing film functioning as the pixel electrode and the common electrode of the interdigital structure is arranged on a same layer as the data line.
9. The array substrate according to any one of claims 6 to 8, wherein, the common electrode is arranged above a film layer of the data line.
10. The array substrate according to any one of claims 6 to 8, wherein, in the respective pixel regions, a transparent conductive metal oxide layer is arranged on the wire grid polarizing film.
11. The array substrate according to claim 10, wherein, in the respective pixel regions, the transparent conductive metal oxide layer and the wire grid polarizing film are consistent in pattern.
12. The array substrate according to any one of claims 1 to 5, wherein, the wire grid polarizing film and the gate line are arranged on a same layer, the wire grid polarizing film functions as a common electrode in the respective pixel regions.

13. The array substrate according to any one of claims 1 to 5, wherein, a pixel electrode is further arranged in the respective pixel regions; the wire grid polarizing film is electrically connected with the pixel electrode in the respective pixel regions. 5
14. The array substrate according to any one of claims 1 to 5, further comprising a common electrode line arranged on a same layer as the gate line and extended in a same direction as the gate line; wherein, the wire grid polarizing film is electrically connected with the common electrode line in the respective pixel regions. 10
15. A liquid crystal display panel, comprising: an array substrate and an opposed substrate arranged oppositely, and a liquid crystal layer filled between the array substrate and the opposed substrate; wherein, the array substrate is the array substrate according to any one of claims 1 to 14. 15
20
16. The liquid crystal display panel according to claim 15, wherein, an upper polarizer is arranged on a side of the opposed substrate away from the array substrate. 25
17. The liquid crystal display panel according to claim 16, wherein, an extending direction of the grating structure of the wire grid polarizing film and a transmission axis direction of the upper polarizer are parallel to each other. 30
18. A display device, comprising the liquid crystal display panel according to any one of claims 15 to 17. 35

40

45

50

55

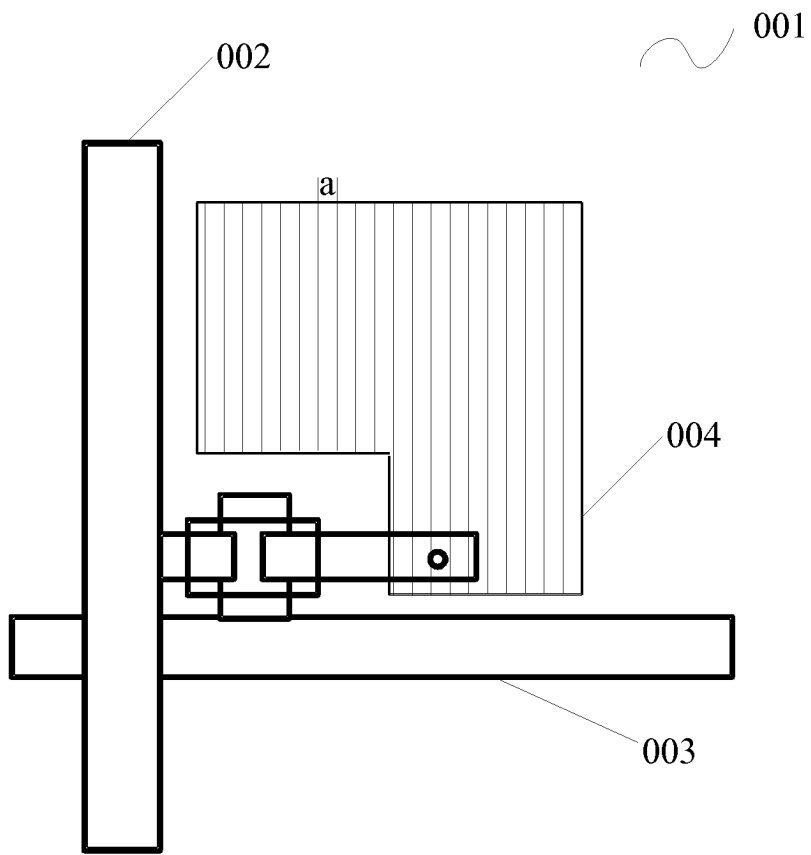

FIG. 1

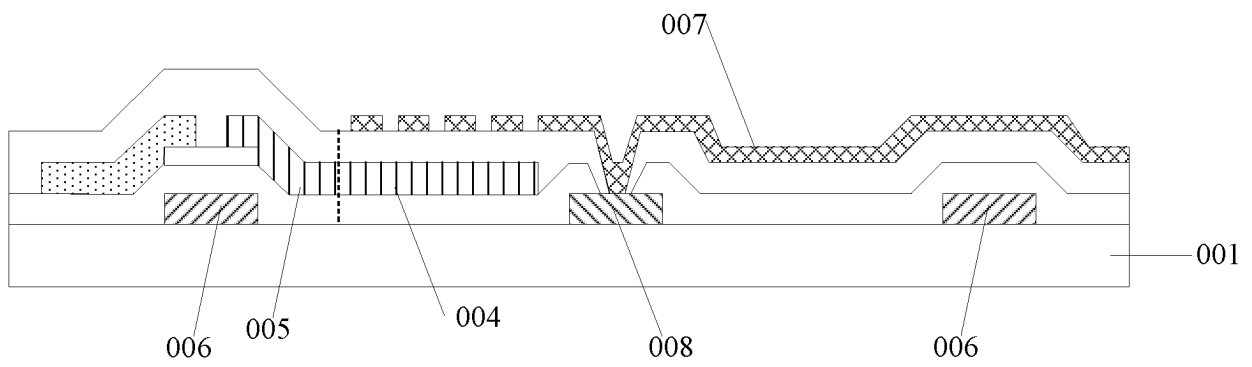

FIG. 2a

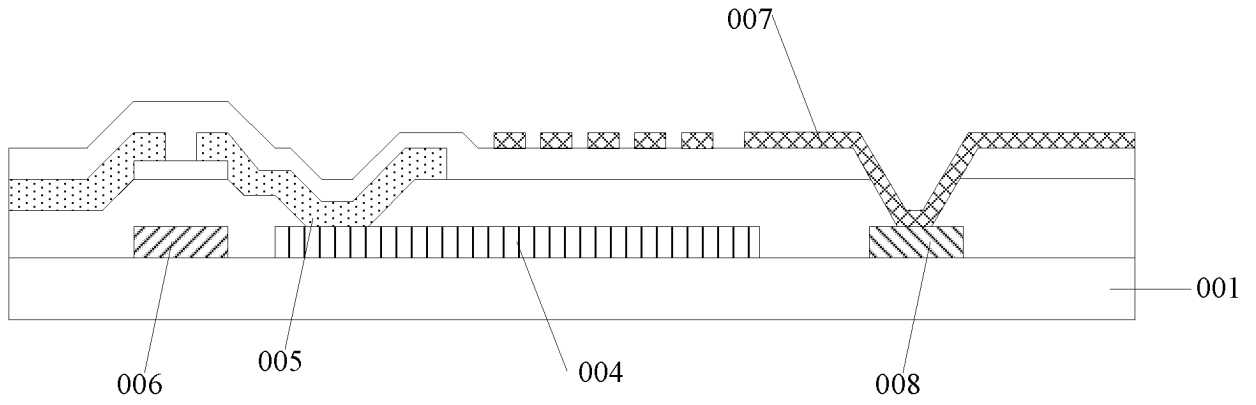

FIG. 2b

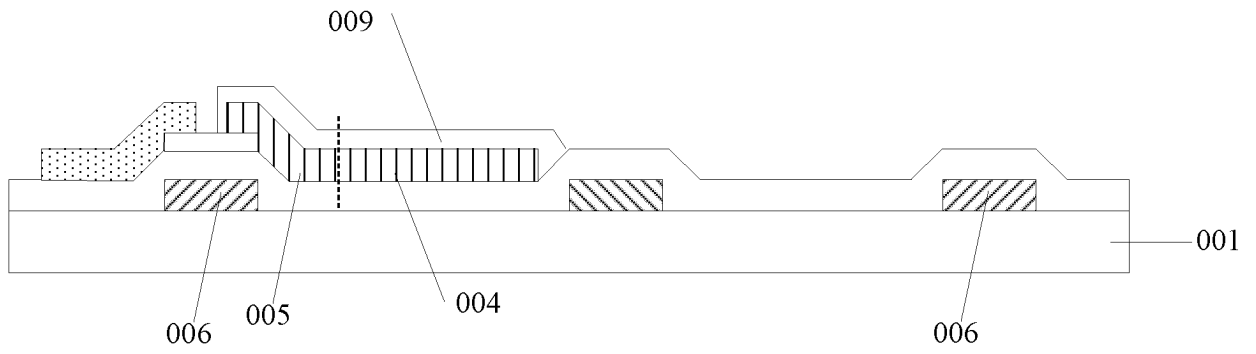

FIG. 2c

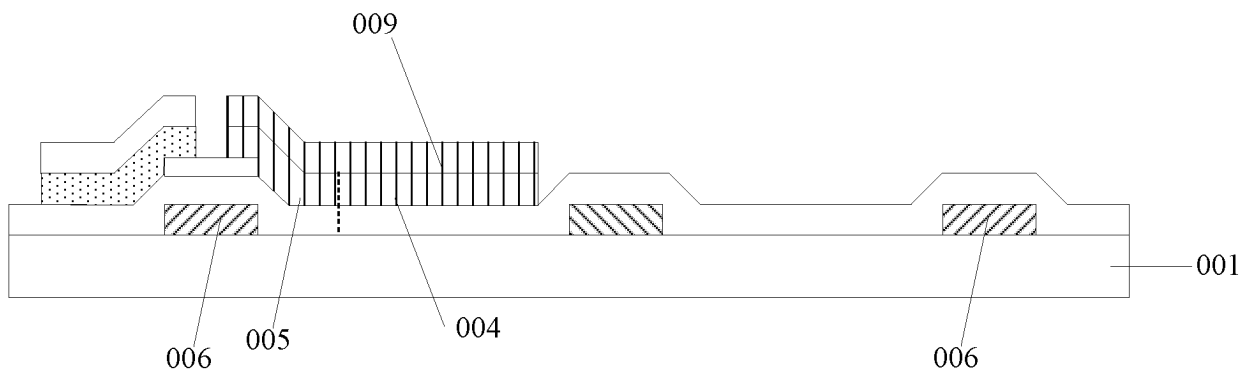

FIG. 2d

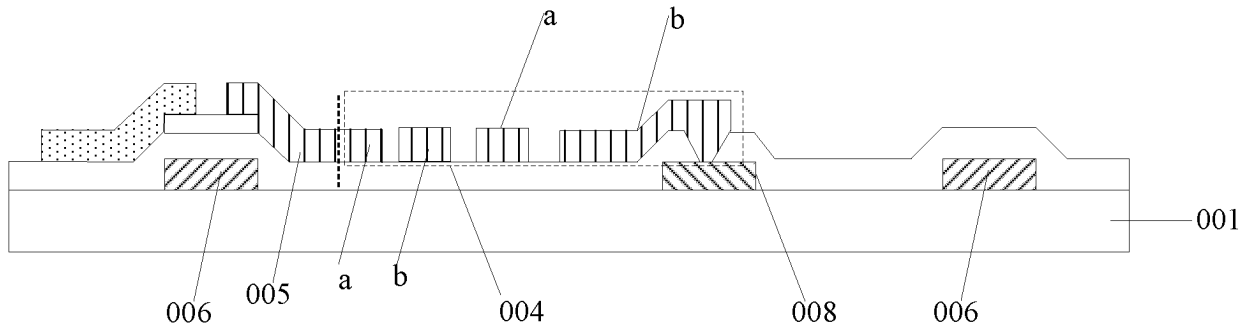

FIG. 3a

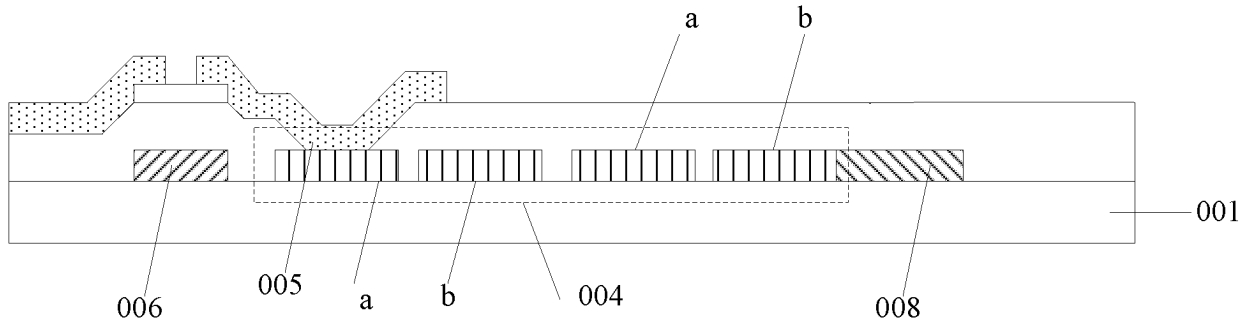

FIG. 3b

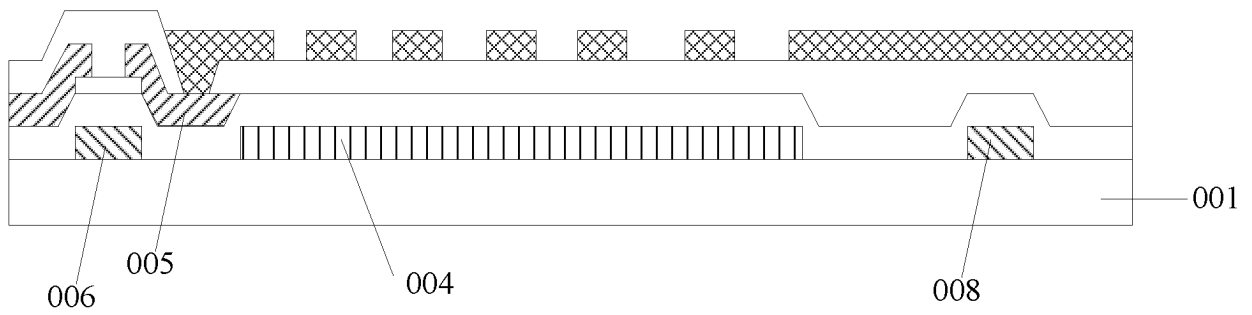

FIG. 4

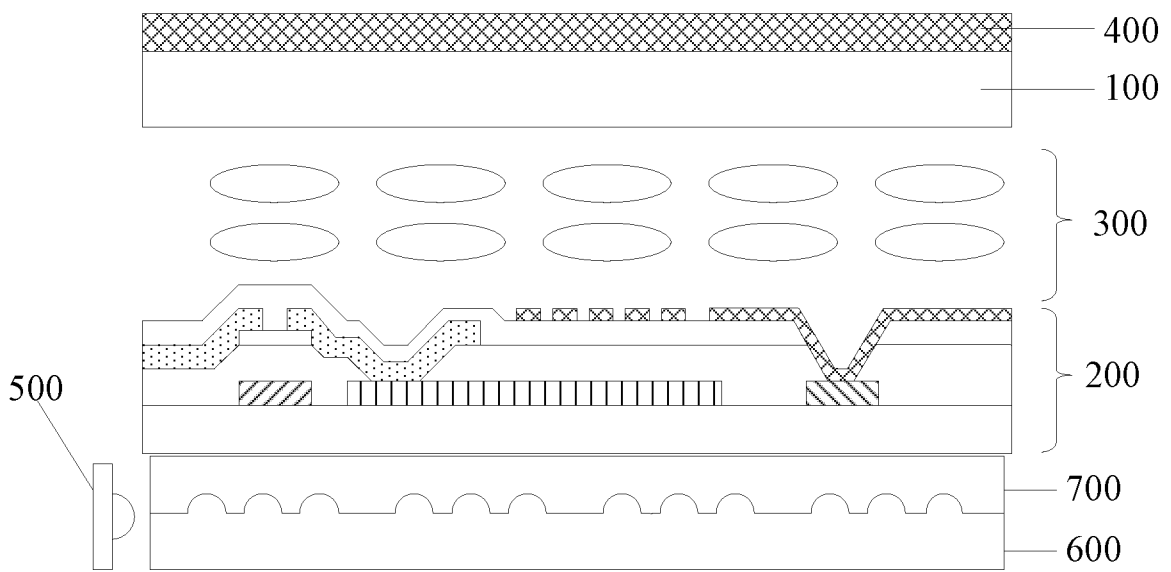

FIG. 5

INTERNATIONAL SEARCH REPORT

International application No.

PCT/CN2015/074455

A. CLASSIFICATION OF SUBJECT MATTER	
G02F 1/1335 (2006.01) i; G02F 1/1343 (2006.01) i According to International Patent Classification (IPC) or to both national classification and IPC	
B. FIELDS SEARCHED	
Minimum documentation searched (classification system followed by classification symbols) G02F 1/-	
Documentation searched other than minimum documentation to the extent that such documents are included in the fields searched	
Electronic data base consulted during the international search (name of data base and, where practicable, search terms used) WPI; EPODOC; CNPAT; CNKI: array substrate, data line, gate line, pixel electrode, common electrode, wire grating; TFT, thin w film w transistor, polar+, data, gate, pixel, electrode, common, wire, pattern, graphic, grid, grat???, built w in	
C. DOCUMENTS CONSIDERED TO BE RELEVANT	
Category*	Citation of document, with indication, where appropriate, of the relevant passages
X	CN 101290446 A (BOE TECHNOLOGY GROUP CO., LTD.), 22 October 2008 (22.10.2008), description, page 5, last paragraph to page 10, paragraph 3, and figures 1-17
X	US 2008100781 A1 (CHOO, D.H. et al.), 01 May 2008 (01.05.2008), description, paragraphs [0073]-[0081], and figures 5A-6C
P, X	US 2015014693 A1 (SAMSUNG DISPLAY CO., LTD.), 15 January 2015 (15.01.2015), description, paragraphs [0052]-[0162], and figures 1-6E
P, X	CN 104330915 A (BOE TECHNOLOGY GROUP CO., LTD.), 04 February 2015 (04.02.2015), description, paragraphs [0031]-[0058]
A	JP 2010160504 A (SEIKO EPSON CORP.), 22 July 2010 (22.07.2010), the whole document
A	JP 5067434 B2 (SEIKO EPSON CORP.), 07 November 2012 (07.11.2012), the whole document
A	CN 101390000 A (RADIANT IMAGES, INC.), 18 March 2009 (18.03.2009), the whole document
<input type="checkbox"/> Further documents are listed in the continuation of Box C. <input checked="" type="checkbox"/> See patent family annex.	
* Special categories of cited documents:	“T” later document published after the international filing date or priority date and not in conflict with the application but cited to understand the principle or theory underlying the invention
“A” document defining the general state of the art which is not considered to be of particular relevance	“X” document of particular relevance; the claimed invention cannot be considered novel or cannot be considered to involve an inventive step when the document is taken alone
“E” earlier application or patent but published on or after the international filing date	“Y” document of particular relevance; the claimed invention cannot be considered to involve an inventive step when the document is combined with one or more other such documents, such combination being obvious to a person skilled in the art
“L” document which may throw doubts on priority claim(s) or which is cited to establish the publication date of another citation or other special reason (as specified)	“&” document member of the same patent family
“O” document referring to an oral disclosure, use, exhibition or other means	
“P” document published prior to the international filing date but later than the priority date claimed	
Date of the actual completion of the international search 05 June 2015 (05.06.2015)	Date of mailing of the international search report 06 July 2015 (06.07.2015)
Name and mailing address of the ISA/CN: State Intellectual Property Office of the P. R. China No. 6, Xitucheng Road, Jimenqiao Haidian District, Beijing 100088, China Facsimile No.: (86-10) 62019451	Authorized officer SONG, Yue Telephone No.: (86-10) 82245970

Form PCT/ISA/210 (second sheet) (July 2009)

INTERNATIONAL SEARCH REPORT
Information on patent family members

International application No.

PCT/CN2015/074455

5

10

15

20

25

30

35

40

45

50

55

Patent Documents referred in the Report	Publication Date	Patent Family	Publication Date
CN 101290446 A	22 October 2008	CN 101290446 B	05 October 2011
		US 8120727 B2	21 February 2012
		US 2009283768 A1	19 November 2009
US 2008100781 A1	01 May 2008	KR 101282323 B1	04 July 2013
		KR 20080037324 A	30 April 2008
		US 8081273 B2	20 December 2011
US 2015014693 A1	15 January 2015	KR 20150008590 A	23 January 2015
CN 104330915 A	04 February 2015	None	
JP 2010160504 A	22 July 2010	None	
JP 5067434 B2	07 November 2012	JP 2010160503 A	22 July 2010
CN 101390000 A	18 March 2009	JP 2008513841 A	01 May 2008
		WO 2006034110 A1	30 March 2006
		US 7480017 B2	20 January 2009
		US 2006061519 A1	23 March 2006
		WO 2006034051 A2	30 March 2006
		WO 2006034015 A1	30 March 2006
		EP 1797549 A2	20 June 2007

Form PCT/ISA/210 (patent family annex) (July 2009)

REFERENCES CITED IN THE DESCRIPTION

This list of references cited by the applicant is for the reader's convenience only. It does not form part of the European patent document. Even though great care has been taken in compiling the references, errors or omissions cannot be excluded and the EPO disclaims all liability in this regard.

Patent documents cited in the description

- CN 201410642435 [0055]

专利名称(译)	阵列基板，液晶显示面板和显示装置		
公开(公告)号	EP3217213A1	公开(公告)日	2017-09-13
申请号	EP2015790436	申请日	2015-03-18
[标]申请(专利权)人(译)	京东方科技集团股份有限公司		
申请(专利权)人(译)	京东方科技集团股份有限公司.		
当前申请(专利权)人(译)	京东方科技集团股份有限公司.		
[标]发明人	LI WENBO		
发明人	LI, WENBO		
IPC分类号	G02F1/1335 G02F1/1343		
CPC分类号	G02F1/133528 G02F1/133514 G02F1/1341 G02F1/134363 G02F1/13439 G02F1/136213 G02F1/136286 G02F1/1368 G02F2001/133548 G02F2001/133565 G02F2001/136295 G02F2201/121 G02F2201/123		
优先权	201410642435.6 2014-11-07 CN		
其他公开文献	EP3217213A4 EP3217213B1		
外部链接	Espacenet		

摘要(译)

提供一种阵列基板，液晶显示面板和显示装置。阵列基板包括：基础基板（001），数据线（002）和栅极线（003），在基础基板（001）上相互交叉，多个像素区域由数据线（002）定义栅极线（003）位于阵列基板上并排列成阵列，线栅偏振膜（004）设置在各个像素区域中，用于将通过其中的自然光改变为线偏振光；其中，各个像素区域中的线栅偏振膜（004）具有光栅结构，因此线栅偏振膜起到偏振器的作用，因此，省略了在单元组装后单独安装偏振器的工艺，其中可以提高生产效率，节省生产成本，有利于显示面板的薄化。

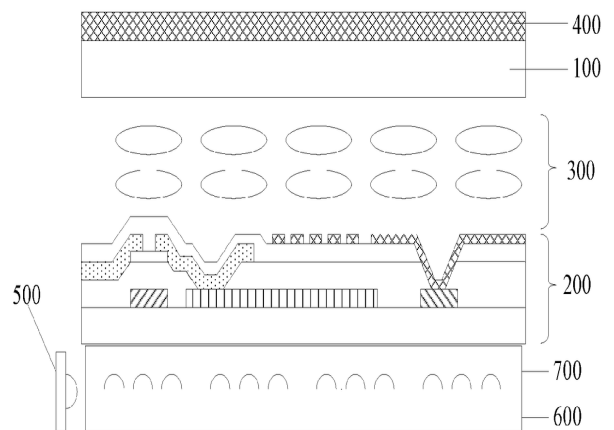

FIG. 5